



Bio-safety principle in dairy laboratory



Food safety principle

Microbial food safety is assured primarily through:

- control of microorganisms at the food source and in raw material selection;
- product design and process control;
- application of Good Hygienic/Manufacturing Practices (GHPs/GMPs); and
- implementation of the Hazard Analysis and Critical Control Point (HACCP) system throughout the food chain (FAO/WHO, 2001; ICMSF, 2002).

What is Bio-safety ?

Development and implementation of administrative policies ,work practices , facility design and safety equipments to prevent transmission of biological agents to worker /other persons, products and the environments



Why bio-safety practices?

To protect:

- workers
- products
- co-workers
- environment
- students
- visitors

Chain of Infection and Means of Protection

Reservoir of pathogen

Portal of escape

Transmission

Route of entry/infectious dose

Susceptible host

Incubation period

Practices/
Equipment

Personal
Protective
Equipment

Immunization

Surveillance

Risk Assessment

Bio-hazardous materials

Materials of biological origin that have the capacity to produce deleterious effects on humans or animals.

Examples of Biohazardous Materials

- Recombinant DNA molecules
- Microorganisms containing recombinant DNA molecules
- Microorganisms classified as risk group 2 3,4
- Biological products derived from RG-2, 3,4 organisms
- Diagnostic specimens known or reasonably expected to contain RG-2, RG-3, or RG-4 organisms.

Hazard Evaluation and Risk Assessment

- To determine the level of containment to handle a biohazardous agent based on the following
 - Virulence
 - Pathogenicity
 - Infectious dose
 - Environmental stability
 - Route of spread
 - Communicability
 - Operations
 - Quantity
 - Availability of vaccine or treatment

Classification of Infectious Agents

- Classified into risk groups on the basis of risk to the individual and to the community.
- Currently, 4 risk group levels have been designated.
- The least risk (RG-1) to the most risk (RG-4).

Bio-safety Principles/safety levels

- *BSL1* - agents not known to cause disease.
- *BSL2* - agents associated with human disease.
- *BSL3* - agents with potential for aerosol transmission; disease may have serious or lethal consequences.
- *BSL4* - agents which pose high risk of life-threatening disease.

RG-1 Agents

- Not associated with disease in healthy adult humans.
- Generally only require a laboratory with minimal containment -Bio-safety Level 1
- “Declaration of Dangerous Goods” is not generally required for transportation by air.

RG-2 Agents

- Associated with human disease which is rarely serious.
- Preventative and therapeutic interventions are available.
- Generally require a laboratory with moderate containment-Bio-safety Level 2
- “Declaration of Dangerous Goods” required for shipment.

RG-3 Agents

- Associated with serious or lethal disease.
 - High individual risk but low community risk
- Preventative or therapeutic interventions may be available.
- Generally require a laboratory with high level containments-Bio-safety level 3
- “Declaration of Dangerous Goods” required for shipment.

RG-4 Agents

- Likely to cause serious or lethal human disease
 - High individual and community risk
- Preventative or therapeutic interventions are not usually available.
- Require a laboratory with extensive high-level containment-Bio-safety level 4
- **Research on these agents are not allowed on campus since a BSL-4 containment lab is not currently available.**

BSL-1 Containment Overview

- **RG-1 Agents**

- Not known to cause disease in healthy adult humans

- **Practices**

- Standard microbiological practices

- **Safety equipment**

- Minimal requirements

- **Facilities**

- Open bench top

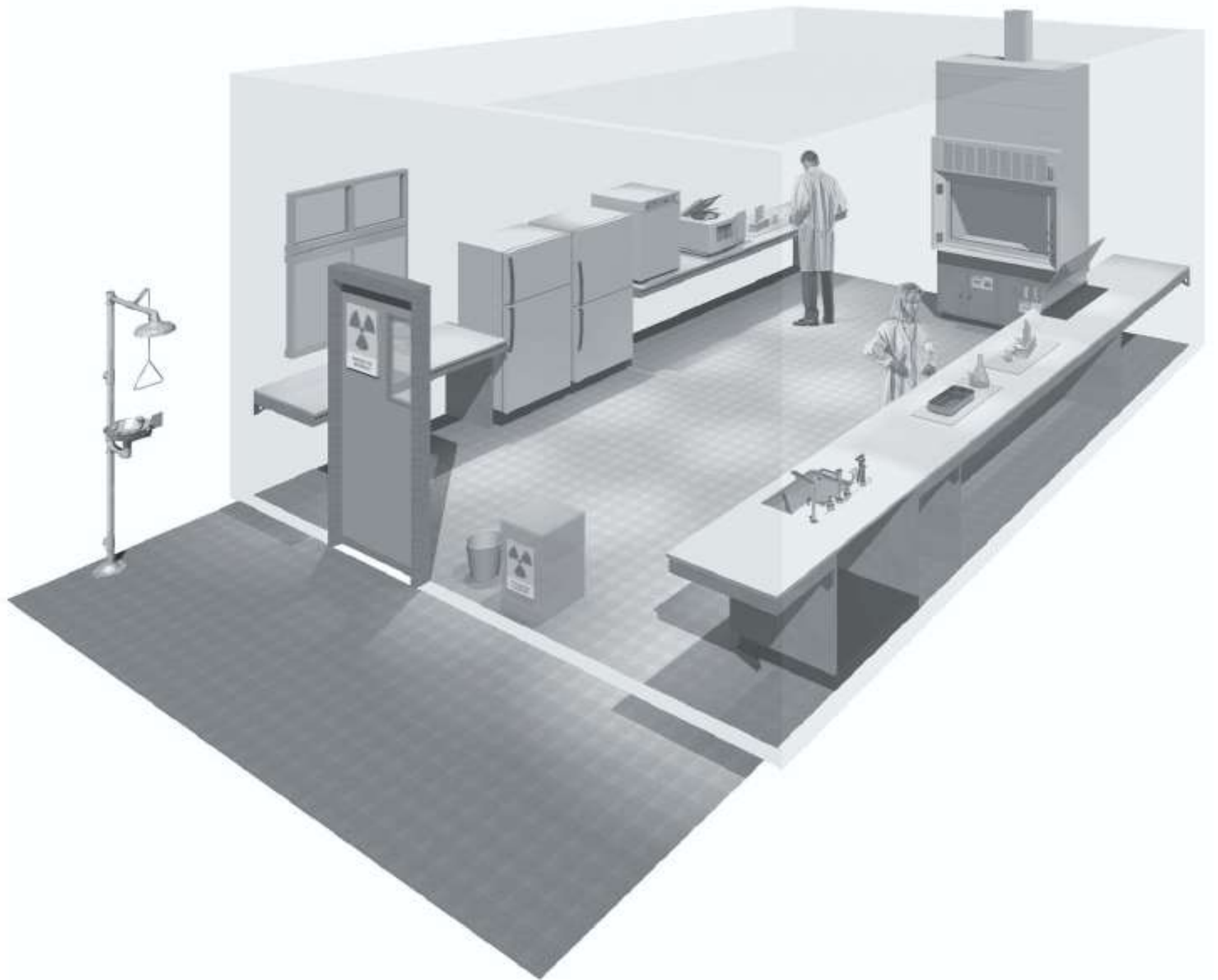

BSL-2 Containment Overview

- **RG-2 Agents**
 - Associated with mild to moderate disease in humans
- **Practices**
 - BSL-1 plus limited access.
- **Safety equipment**
 - Biological Safety Cabinet and personal protective equipment as needed.
- **Facilities**
 - BSL-1 plus the availability of a mechanism for decontamination.

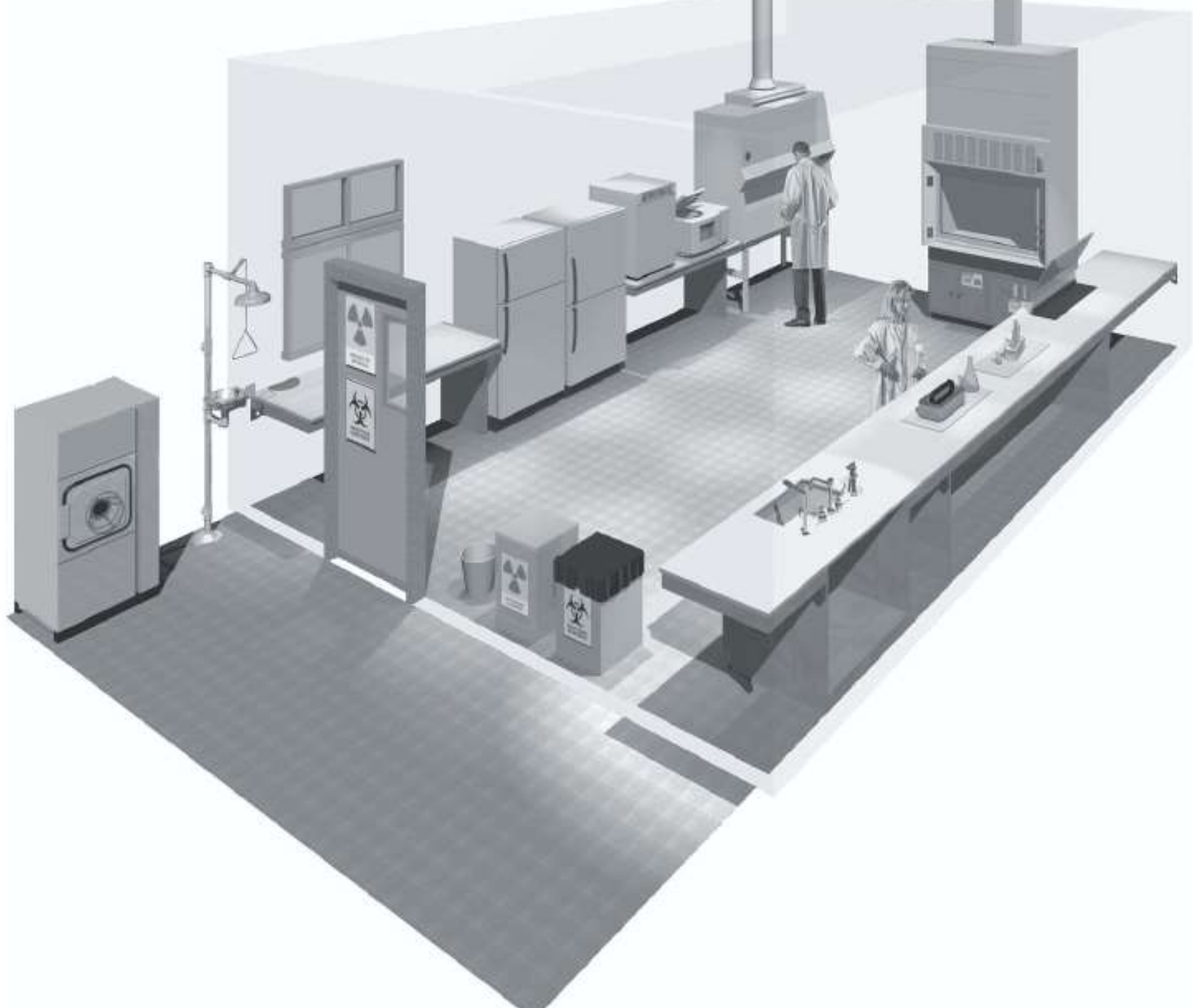

BSL-3 Containment Overview

- **RG-3 Agents**
 - Associated with serious or potentially lethal disease in humans
- **Practices**
 - BSL-2 plus controlled access.
- **Safety equipment**
 - Biological Safety Cabinet and personal protective equipment required.
- **Facilities**
 - BSL-2 with self-closing double door access and single-pass negative directional airflow.

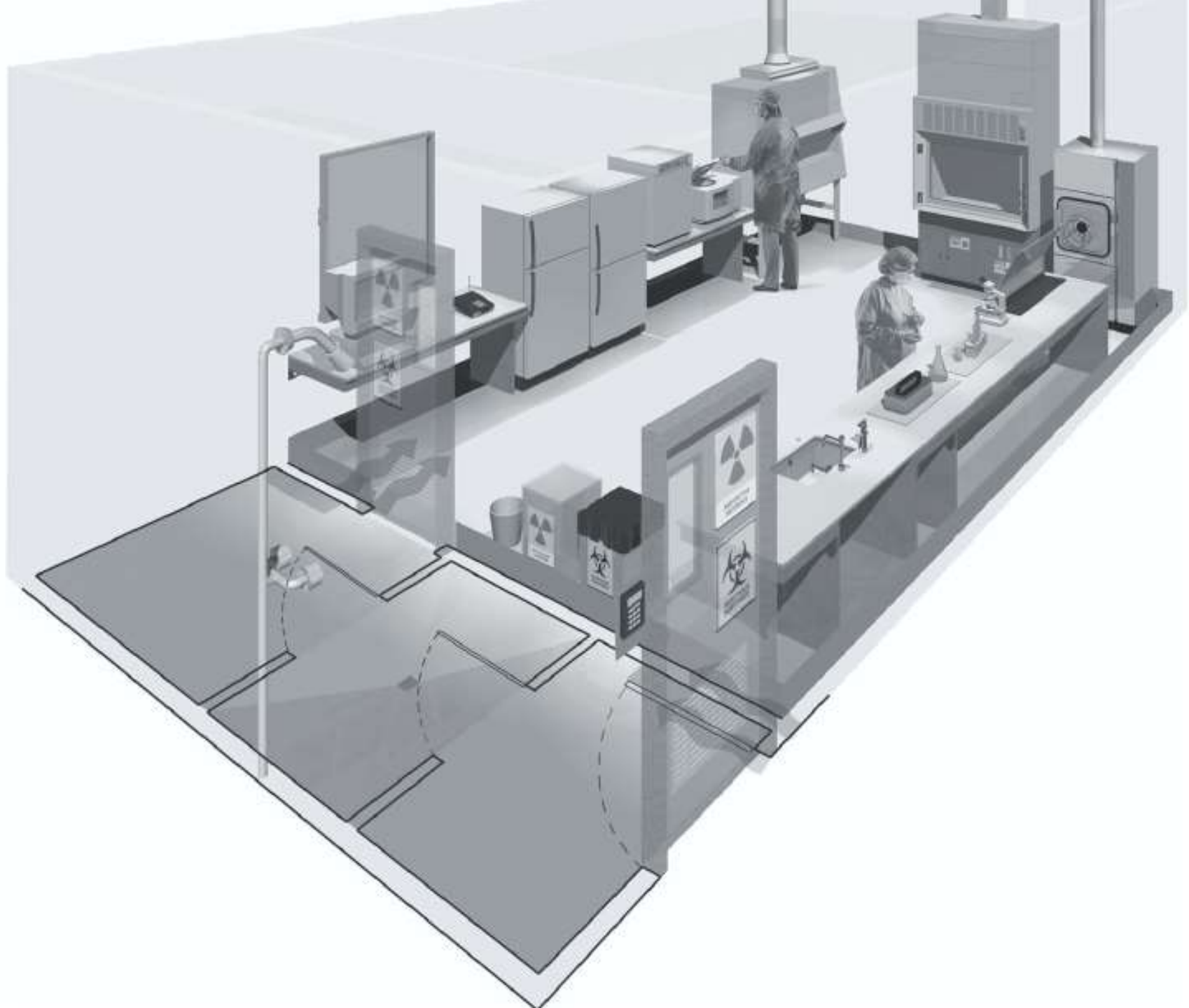

BSL-4 Containment Overview

- RG-4 Agents- Associated with high risk of life-threatening disease in humans and/or animals
- Practices-BSL-3 plus controlled access
- Safety equipment
 - Biological Safety Cabinet
 - Full-body air-supplied, positive pressure personnel suit
- Facilities- BSL-3 plus dedicated air and exhaust, decontamination procedures for exit, separate building, etc.

Risk Group vs Biosafety Level

- Biosafety risk assessment
 - To determine the risk group of a biological agent
- RG-2 organisms are generally handled in BSL-2 containment and RG-3 in BSL-3.
- Exceptions
 - RG-2 agents used in large quantities may require BSL-3 containment
 - RG-3 agents under some circumstances may be manipulated at BSL-2 containment.

Designing for bio-safety

- General requirements
 - Standard lab practices
 - Facility design
 - Water supply/sinks for hand washing
 - Ventilation
- Safety equipment
 - Personal protective equipment (PPE)
 - Biosafety cabinets

BSL-1 Standard Microbiological Practices

- Restrict or limit access when conducting research
- Prohibit eating, drinking and smoking
- Prohibit mouth pipetting



BSL-1 Standard Microbiological Practices



Use
mechanical
pipetting
devices

BSL-1 Standard Microbiological Practices



Wash hands

BSL-1 Standard Microbiological Practices

- Minimize splashes and aerosols
- Decontaminate work surfaces daily
- Decontaminate infectious waste
- Maintain an insect & rodent control program

BSL-1 Safety Equipment (Primary Barrier)

- Personal protective equipment
 - Face shield
 - Eye wear
 - Gloves
 - Lab coat



-  room air
-  potentially contaminated air
-  HEPA-filtered air

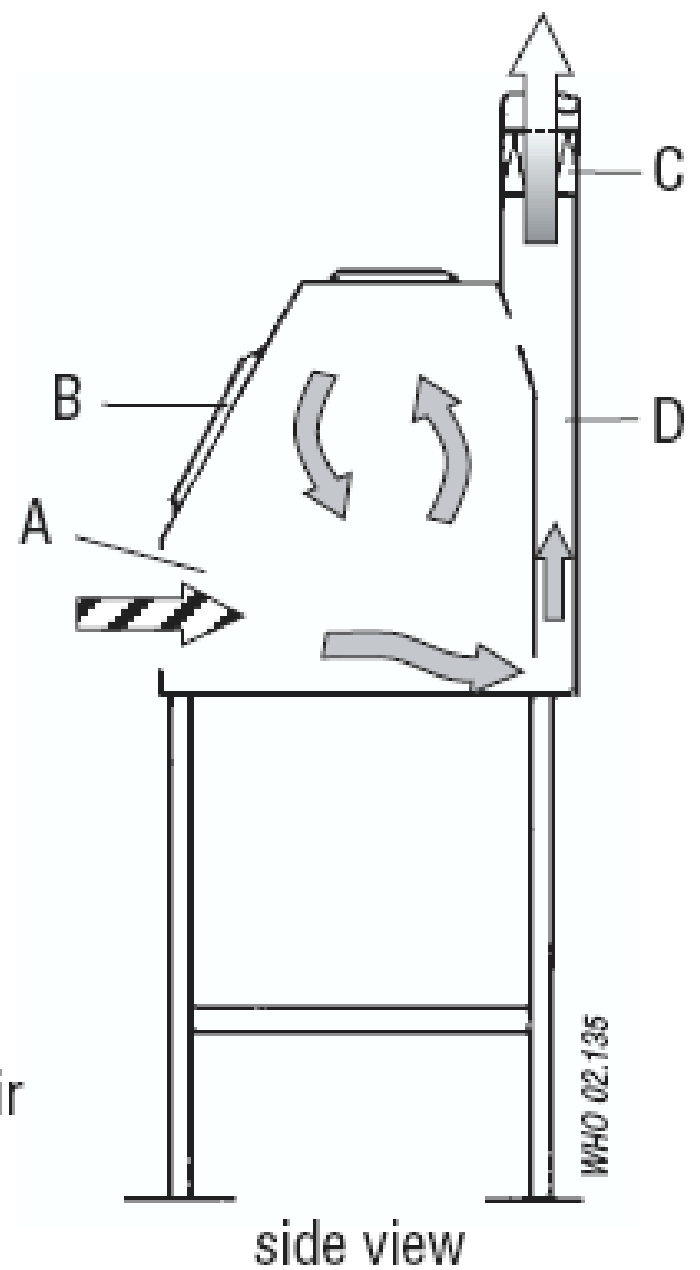

Figure 6. Schematic diagram of a Class I biological safety cabinet.

BSL-1 Facility Design (Secondary Barrier)



Countertops and floors easily cleaned and decontaminated

BSL-1 Facility Design (Secondary Barrier)

Requirements:

- Lab Location: -not separated from other lab sections
- Structure: -normal construction
- Ventilation: -no specific requirements

BSL-2 Standard Microbiological Practices

- Follow all practices used for BSL-1 containment.

BSL-2 Safety Equipment (Primary Barrier)

- Class II Biological Safety Cabinet recommended
 - To protect product, personnel, and the environment.

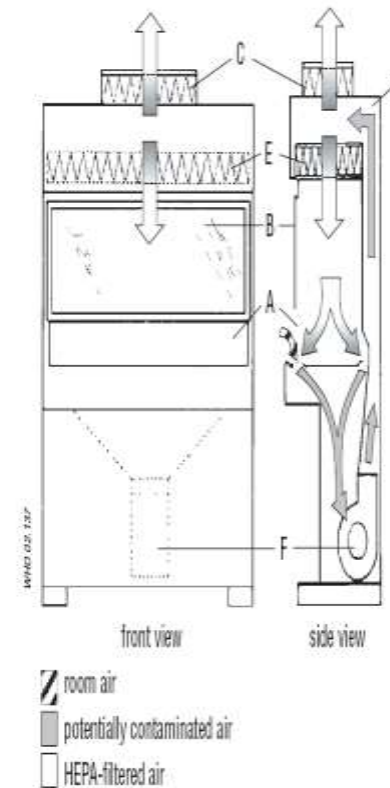

Figure 7. Schematic representation of a Class IIA1 biological safety cabinet.

BSL-2 Facility Design (Secondary Barrier)

Requirements:

- Laboratories have lockable doors
- Sink for hand washing
- Work surfaces easily cleaned
- Bench tops are impervious to water
- Sturdy furniture

BSL-2 Facility Design (Secondary Barrier)

- **Requirements:**

- Adequate illumination
- Air flows into lab without re-circulation to non-lab areas
- Windows fitted with fly screens

BSL-2 Facility Design (Secondary Barrier)



Signage on the door with restricted access when work in progress.

BSL-2 Facility Design (Secondary Barrier)

- BSL-1 Facilities PLUS:



- Decon method
 - Autoclave may be available
 - Off-site program
- Eyewash station present

BSL-2 Facility Design (Secondary Barrier)

Requirements:

- Location: separated from public areas
- Structure: normal construction
- Ventilation: directional

Biosafety Level 3 *Standard Microbiological Practices*

As used in
BSL-1 & 2



Biosafety Level 3: Safety Equipment (Primary Barriers)

- BSL-1 and 2 Safety Equipment PLUS:
Class II A or B biological safety cabinet to
manipulate infectious materials

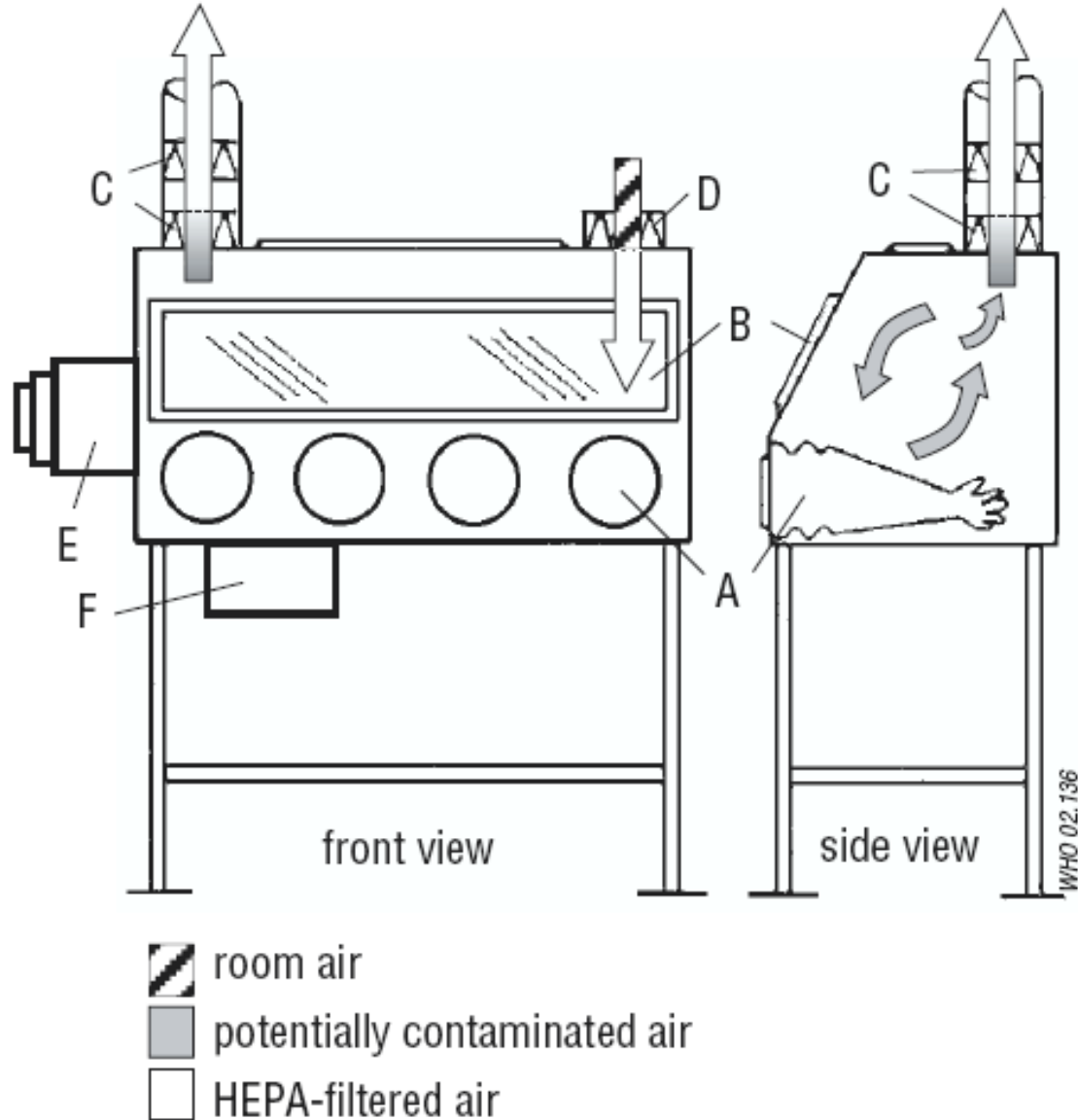

Figure 9. Schematic representation of a Class III biological safety cabinet (glove box). A, glove ports for arm-length gloves; B, sash; C, double-exhaust HEPA filters; D, supply HEPA filter; E, double-ended autoclave or pass-through box; F, chemical dunk tank. Connection of the cabinet exhaust to an independent building exhaust air

Table 9. Differences between Class I, II and III biological safety cabinets (BSCs)

BSC	FACE VELOCITY (m/s)	AIRFLOW (%)		EXHAUST SYSTEM
		RECIRCULATED	EXHAUSTED	
Class I ^a	0.36	0	100	Hard duct
Class IIA1	0.38–0.51	70	30	Exhaust to room or thimble connection
Class IIA2 vented to the outside ^a	0.51	70	30	Exhaust to room or thimble connection
Class IIB1 ^a	0.51	30	70	Hard duct
Class IIB2 ^a	0.51	0	100	Hard duct
Class III ^a	NA	0	100	Hard duct

NA, not applicable.

^a All biologically contaminated ducts are under negative pressure or are surrounded by negative pressure ducts and plenums.

Biosafety Level 3 *Safety Equipment (Primary Barriers)*

- Respiratory protection may be recommended but not always required
 - Laboratory specific requirement
 - N95 respirator commonly used
 - Fit testing required through Employee Health



Biosafety Level 3 *Laboratory Facilities (Secondary Barriers)*

- BSL-1 and 2 Facilities PLUS:
 - Separate building or isolated zone
 - Double-door entry; doors are self-closing
 - Directional inward airflow (negative pressure)
 - Hands-free or automatically operated sink with eye wash station

Biosafety Level 3 *Laboratory Facilities (Secondary Barriers)*

- Enclosures required for aerosol generating equipment
- Room penetrations sealed
- Walls, floors and ceilings are water resistant for easy cleaning
- Visual and audible alarms for air system failure notification

Biosafety Level 3 *Laboratory Facilities (Secondary Barriers)*

- Documented facility design and operational procedures.
- Facility tested for operational verification prior to use
- Facility re-verified, at least annually,

Biosafety Level 3 *Special Practices*

- Work in certified biological safety cabinet
 - Certified annually!!!
- Decontaminate spills promptly



Biosafety Level 3 *Special Practices*

- Lab Personnel must:
 - Strictly follow guidelines
 - Demonstrate proficiency
 - Receive appropriate training
 - Report incidents
 - Participate in medical surveillance program
 - Be trained in biosecurity procedures

Biosafety Level 3

Medical Surveillance: *Criteria*

Medical Surveillance criteria is based on a risk assessment of the biological agents used

Biosafety Level 3

Medical Surveillance : **Risk Assessment**

- What is the natural host of the biological agent?
- Does the agent cross species barriers?
- Is it a wild-type agent or attenuated?
- Is the agent infectious for a normal healthy adult?
- What effect will the agent have on an adult if immunocompromised? if pregnant?

Biosafety Level 3

Medical Surveillance :Risk Assessment

- What is the mode of transmission for the agent?
 - contact
 - mucous membrane exposure
 - ingestion
 - inoculation
 - inhalation

How is Agent being Manipulated?

TABLE 56.5. *Aerosol output for select procedures and accidents involving suspension with concentration of 10^{10} viable organisms per milliliter*

Procedure or Accident	Spray factor	Aerosol output
Blending completed, top removed	1.2×10^{-4}	1.2×10^6 particles/min
Mix culture in blender, loose cover	4×10^{-7}	4×10^3 particles/min
Using sonic oscillator Minimal aeration	5×10^{-7}	5×10^3 particles/min
Maximal aeration	1×10^{-4}	1×10^6 particles/min
Overflow from <i>mechanical mixer</i>	8×10^{-8}	8×10^2 particles/min
Streaking Petri plate	4×10^{-8}	4×10^2 particles
Dropping flask of culture	3×10^{-5}	3×10^5 particles
Remove cotton plug from centrifuge tube	3×10^{-8}	3×10^2 particles
Insert inoculating loop	3×10^{-8}	3×10^2 particles
Opening lyophilized cultures	2×10^{-9}	2×10^1 particles

TABLE 56.4. *Viable particles recovered per cubic foot of air sampled during procedures and accidents*

Procedure or accident	No. of particles
Using sonic oscillator (minimal aeration)	6
Mixing culture with pipette	7
Overflow from mechanical mixer	9
Opening lyophilized cultures	135
Blending completed, top removed	1,500
Dropping flask of culture	1,551
Dropping lyophilized culture	4,839

TABLE 56.3. *Range of viable particles recovered by air sampling during the procedure or accident specified*

Pipette 30-mL culture into 50-mL test tube	0–5.5
Remove cotton plug from centrifuging tube	0.8–5
Remove cotton plug wet from flask after shaking	0–35
Remove 1 mL from vaccine vial by syringe	0.6–19
Streaking of Petri plate	0–20
Insert inoculating loop (hot) into 100-mL culture	6–24
Decant centrifuge culture into flask	0–115
Mix culture in blender with worn bearing	12–126
Mix culture in blender with loose cover	77–1,246
50-mL tube shatters and splashes in centrifuge	80–1,800

Biosafety Level 3

Medical Surveillance :Risk Assessment

- What volume of the agent is being manipulated?
- What is the concentration of the agent?
- What is the infectious dose of the agent?

TABLE 56.1. *Infective dose for 25% to 50% of volunteers*

Disease or agent	Inoculation route	Dose ^a
Scrub typhus	Intradermal	3 ^b
Q fever	Inhalation	10
Tularemia	Inhalation	10
Malaria	Intravenous	10
Syphilis	Intradermal	57
<i>Shigella flexneri</i>	Ingestion	180
Anthrax	Inhalation	≥1,300
Typhoid fever	Ingestion	10 ⁵
Tularemia	Ingestion	10 ⁸
Cholera	Ingestion	10 ⁸
<i>Escherichia coli</i>	Ingestion	10 ⁸
Shigellosis	Ingestion	10 ⁹

^aDose is in number of organisms.

^bMouse median infective dose (ID₅₀) in this one instance.

Biosafety Level 3

Medical Surveillance [Risk Assessment](#)

- Prophylaxis
 - What, if any immunizations are required?
 - What pharmaceuticals are available?
 - What is the effectiveness of prophylaxis?
- Post-Exposure
 - What are the anti-microbial agents available for treatment?
 - What is the effectiveness of treatment?

Biosafety Level 3

Medical Surveillance Risk Assessment

- When dealing with an unknown agent
 - Is there any known epidemiological data?
 - Are there any patterns parallel to other agents?
 - Is there any data from animal studies?
 - Is the route of infection known?

Biosafety Level 3

Emergency Response

Must be outlined for each laboratory and include:

- Contact information
- Security/Dispatch personnel
- Laboratory Safety and Security Officer
- Institutional Biosafety Officer
- A list of
 - agents secured in laboratory
 - researchers allowed access to each agent
 - the personal protective equipment and immunizations required

Biosafety Level 3

Emergency Response

Procedures must be outlined for the following:

- Major and minor spills outside the biological safety cabinet
- Failure of the biological safety cabinet
- Loss of power
- Fire
- Security breaches

Biosafety Level 4 – Maximum Containment

- BSL -3 practices plus:
 - Clothing change before entering laboratory
 - Shower on exit
 - All materials decontaminated on exit from facility
- Safety Equipment:
 - Class III Biosafety cabinet



Biological Waste

- Types
 - cultures, stocks, isolates
 - materials containing or contaminated
 - pipettes, wrappers, tips
 - All materials used in the lab

Specimen Disposal



Decontamination

- Sterilization
- Disinfection



Decontamination

Definition

- **Sterilization**

The use of a physical or chemical procedure to destroy all microbial life, including large numbers of highly resistant bacterial spores.

Decontamination

Definition

- Disinfection

The use of a physical or chemical procedure to virtually eliminate all recognized pathogenic microorganisms but not all microbial forms (bacterial endospores) on inanimate objects.

Decontamination

Methods

- Heat
- Chemical
- Radiation



Decontamination

Heat

- Types
 - Moist – steam
 - Dry-Incineration

The most effective method of sterilization

Decontamination

Chemical

- Types
 - Liquids, i.e. chlorox, hydrogen peroxide
 - Gases, i.e. ethylene oxide



Decontamination

Chemical

- General Lab Use - *Hypochlorite Solutions*
 - Large Spills/Large Organic Load
 - undiluted from bottle
 - Small Spills/Virus Inactivation
 - 10% 1:9
 - General Surface Disinfection
 - 1% - 1:99



In case of a spill

- Wear disposable gloves
- Cover large spill with paper towels and soak with **1%** (10000 ppm) of household bleach and allow to stand for at least 5 minutes
- Small spill - wipe with paper towel soaked in **1%** bleach
- Discard contaminated towels in infective waste containers
- Wipe down the area with clean towels soaked in a same dilution of household bleach

Safety Documentation & Records

- Laboratory Safety Manual - Policies and Procedures
- *Sample Contents:*
 - Housekeeping
 - Personal protection
 - Safe decontamination of equipment
 - Decontamination & Waste Disposal
 - Emergency procedures
 - In-lab first aid
 - Accidental injury
 - Post exposure prophylaxis
 - Contacts
 - Personnel responsibilities
 - Hygiene

Safety Resources

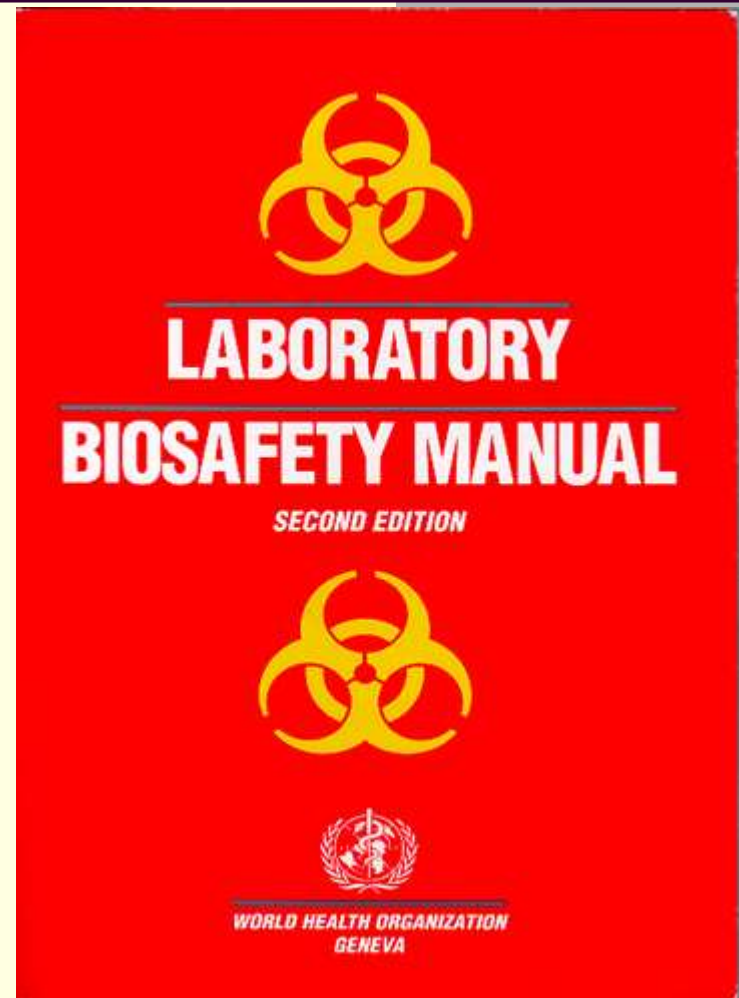
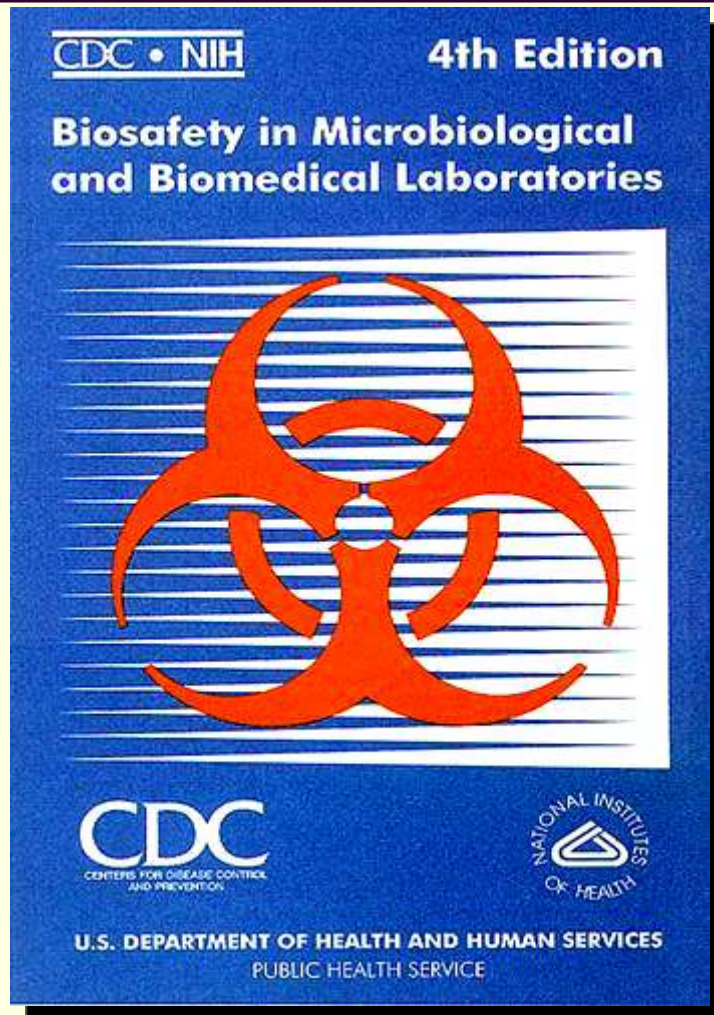

FDA requirements for pathogen testing in a dairy plant

- Physical separation from the food manufacturing environment.
- An air handling system designed to produce a negative pressure in the laboratory and to remove biological agent.(filtered air)
- A qualified microbiologist with at least two years of laboratories experience
- Source : FDA recommended guidelines for controlling environmental and product contamination in dairy plant

Adherence to the safety requirements for a bio-safety level 2 laboratory

- Limited access with in the laboratory
- Decontamination of liquid and solid waste before disposal
- No mouth pipetting
- No eating , drinking or smoking in the laboratory
- Warning sign of biohazard
- Lab coat worn in the laboratory only
- Biosafety manual
- Laboratory is designed to be easily cleaned
- Impervious bench top (easy to clean and sanitize)
- Sink for hand washing

Cont.

- Pathogen monitoring program to assess the risk of cross contamination of tests and food plant
- Use of known positive cultures to verify recovery , consequently requiring strict adherence to these other requirements.

Biosafety Officer

Appointed by the organization with duties to include

1. Periodic inspections to ensure that laboratory standards are rigorously followed
2. Reporting on any significant problems and significant research-related accidents or illnesses;
3. Developing an emergency plan for handling accidental spills and personnel contamination;
4. Providing advice on laboratory security; and
5. Providing technical advice to other lab personnel on research safety procedures

Cont..

- Make available to all laboratory staff the protocols that describe the potential biohazards and the precautions to be taken;
- Instruct and train laboratory staff in the practices and techniques required to ensure safety and the procedures dealing with accidents;
- Inform the lab staff of the reasons and provisions for any precautionary medical practices advised or requested;
- Supervise the safety performance of the laboratory staff;
- Investigate and report any significant problems pertaining to the operation and implementation of containment practices
- Correct work errors and conditions that may result in a release of a biohazardous agent; and
- Ensure the integrity of the physical and biological containment.

Biosafety Lab Manual Components

- Standard Operating Procedures
- Laboratory inspection checklist
- Emergency plan for handling spills and personnel contamination
- Relevant reference materials
 - Information on the biology of the organism(s) used in the laboratory
 - policies pertaining to biosafety

