



Centurion
UNIVERSITY

*Shaping Lives...
Empowering Communities...*

ANGLE MODULATION

Electronics & Communication Engg. Dept.

School of Engineering & Technology

CUTM

Modulation

Amplitude
Modulation

Angle
Modulation

Double
Sideband

Single
Sideband

Vestigial
sideband

Quadrature
Amplitude
Modulation

Phase
Modulation

Frequency
Modulation

Angle Modulation

Let $\theta_i(t)$ be the instantaneous angle of a modulated sinusoidal carrier, i.e.,
 $m'(t)$

where A_c is the constant amplitude.

The instantaneous frequency is

$$s(t) = A_c \cos \theta_i(t),$$

Observation: The signal $s(t)$ can be thought of as a rotating phasor of length A_c and angle $\theta_i(t)$.

$$\omega_i(t) = \frac{d\theta_i(t)}{dt}.$$

If $s(t)$ were an unmodulated carrier signal, then the instantaneous angle would be

$$\theta_i(t) = \omega_c t + \phi_c$$

where $\omega_c \equiv$ Constant angular velocity in rad/s

$\phi_c \equiv$ Constant but arbitrary phase angle in radians

Let $\theta_i(t)$ be varied linearly with the message signal $m(t)$ and $\phi_c = 0$, then

$$\theta_i(t) = \omega_c t + k_p m(t),$$

where $k_p \equiv$ Phase sensitivity of the modulator in rad/volt

In this case we say that the carrier has been **phase modulated**.

The phase modulated waveform is given by

$$s_{PM}(t) = A_c \cos(\omega_c t + k_p m(t))$$

Let the instantaneous frequency $\omega_i(t)$ be varied linearly with the message signal $m(t)$, i.e.,

$$\omega_i(t) = \omega_c + k_\omega m(t)$$

where $k_\omega \equiv$ Frequency sensitivity of the modulator in rad/s/volt

In this case we say that the carrier has been **frequency modulated** and the instantaneous angle is obtained by integrating the instantaneous frequency, i.e.,

$$\theta_i(t) = \int_0^t \omega_i(\tau) d\tau = \int_0^t [\omega_c + k_\omega m(\tau)] d\tau = \omega_c t + k_\omega \int_0^t m(\tau) d\tau$$

The modulated waveform is therefore described by

$$s_{FM}(t) = A_c \cos\left(\omega_c t + k_\omega \int_0^t m(\tau) d\tau\right)$$

Observation: Both phase and frequency modulation are related to each other and one can be obtained from the other. Hence, we could deduce the properties of one of the two modulation schemes once we know the properties of the other.

Relationship between Phase Modulation (PM) and Frequency Modulation (FM)

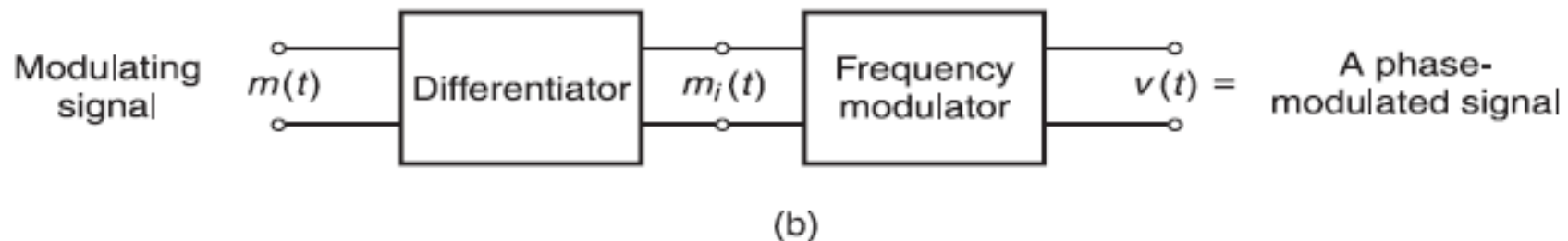
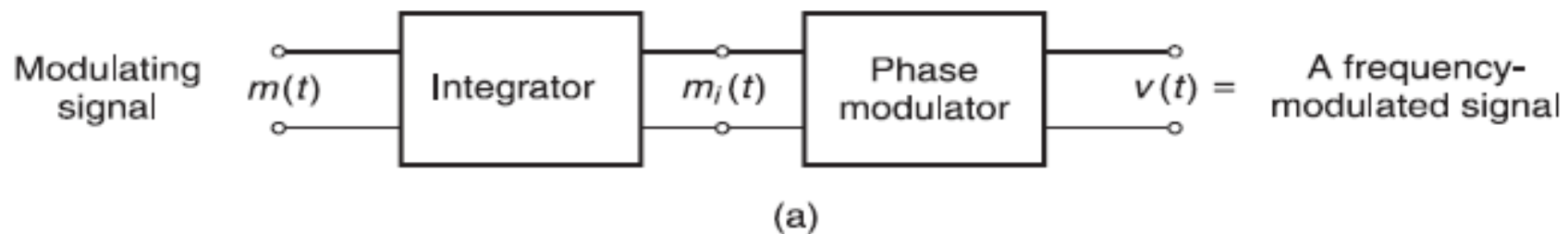

$$v(t) = A \cos [\omega_c t + k' m_i(t)]$$

$$v(t) = A \cos \left[\omega_c t + k \int_{-\infty}^t m(t) dt \right]$$

$$\omega = \frac{d}{dt} \left[\omega_c t + k \int_{-\infty}^t m(t) dt \right] = \omega_c + km(t)$$

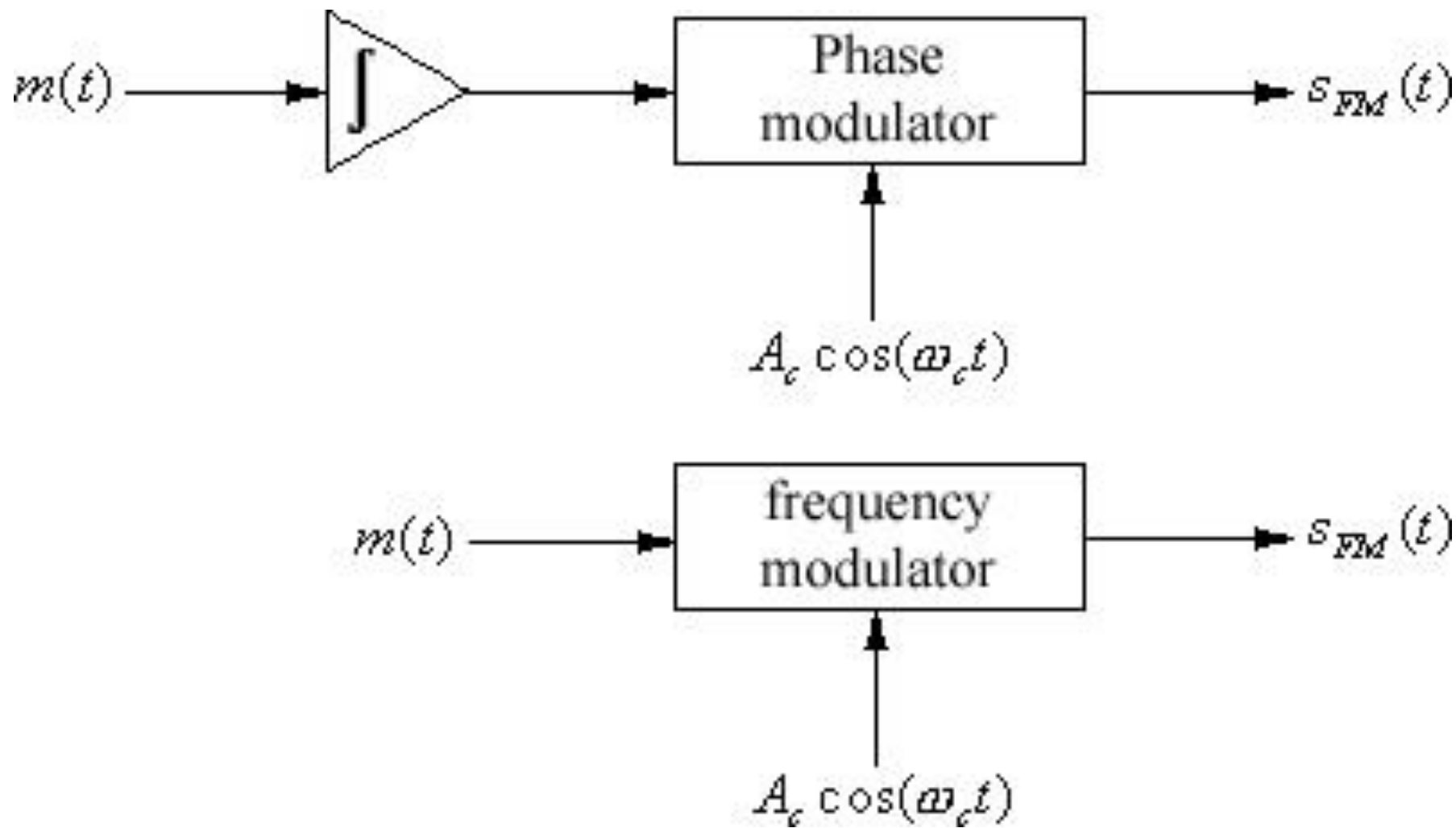

FM modulation

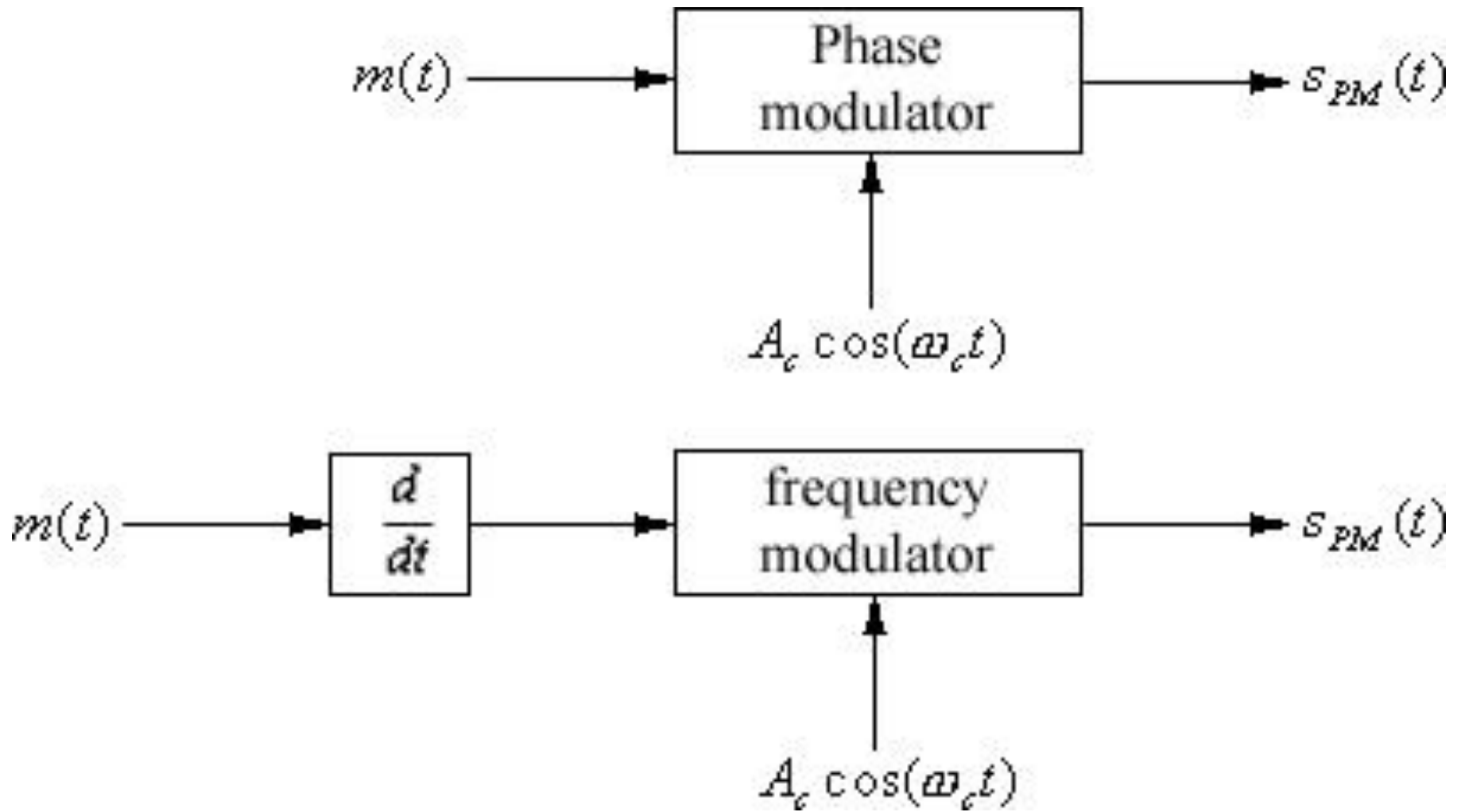

PM modulation

The figure below shows a comparison between AM, FM and PM modulation of the same message waveform:

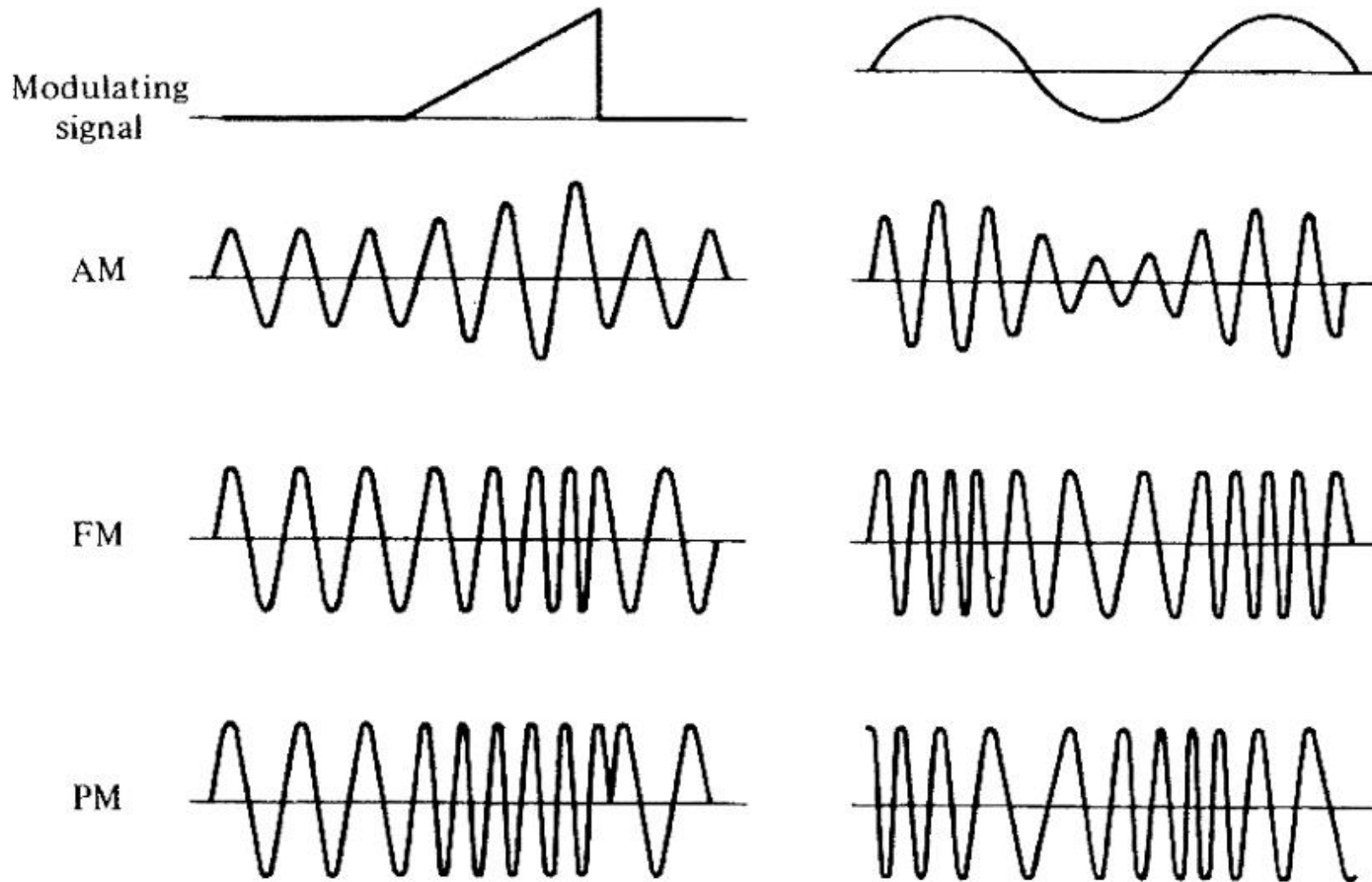

FM Generation

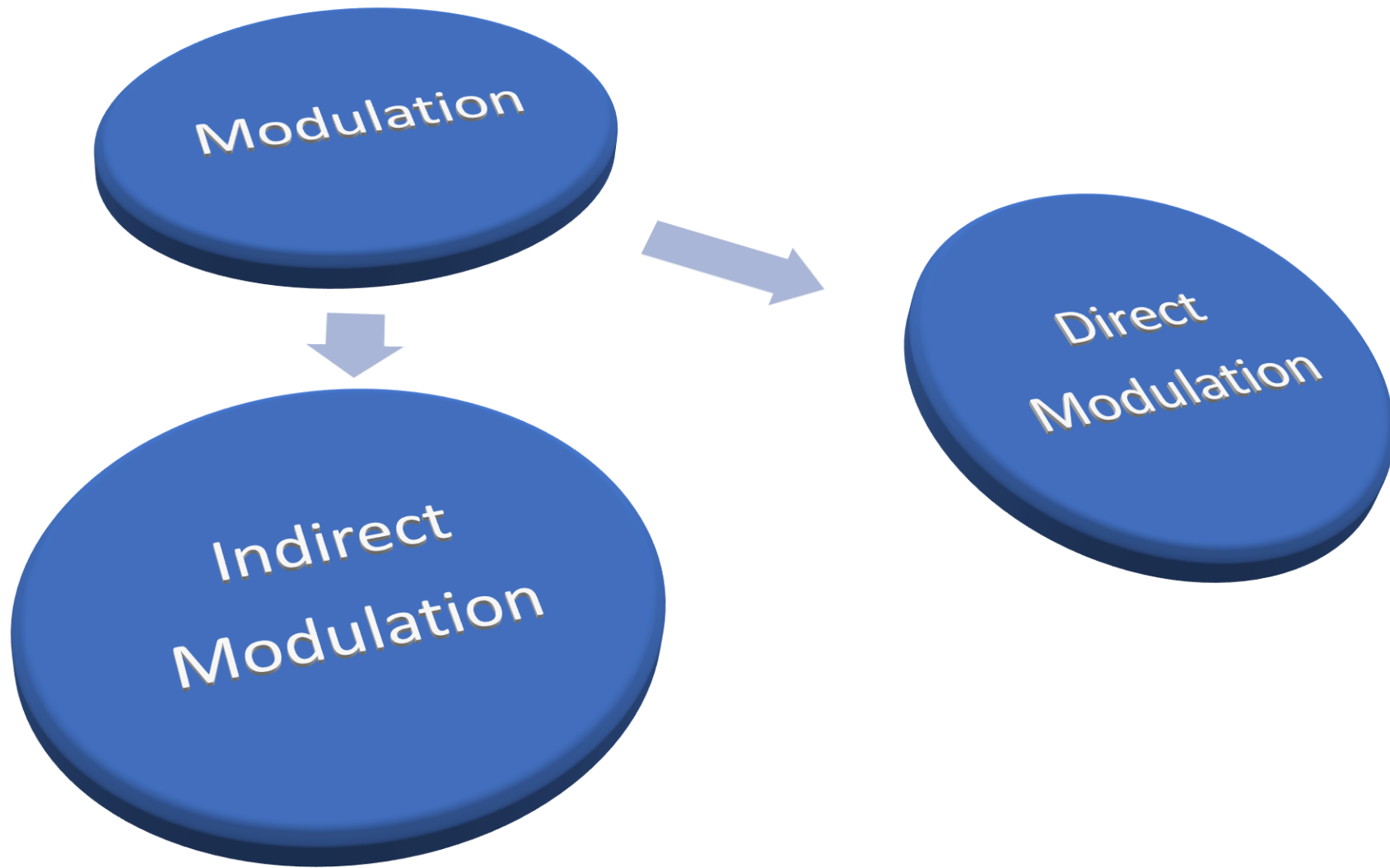

Frequency Modulation

Consider the frequency modulation of the message (tone)

$$m(t) = A_m \cos(2\pi f_m t),$$

The instantaneous frequency (in Hz) of the FM signal is

$$f_i(t) = f_c + k_f A_m \cos(2\pi f_m t).$$

Define the maximum frequency deviation as

$$\Delta f = k_f A_m.$$

The instantaneous phase angle of the FM signal is

$$\begin{aligned}\theta_i(t) &= 2\pi \int_0^t f_i(\tau) d\tau \\ &= 2\pi f_c t + k_f \frac{A_m}{f_m} \sin(2\pi f_m t) \\ &= 2\pi f_c t + \beta \sin(2\pi f_m t)\end{aligned}$$

where $\beta = k_f A_m / f_m$ is known as the FM modulation index (for a tone) or the maximum phase deviation (in rad) produced by the tone in question

The FM modulated tone is therefore given by:

$$\begin{aligned} s_{FM}(t) &= A_c \cos(2\pi f_c t + \beta \sin(2\pi f_m t)) \\ &= A_c [\cos(2\pi f_c t) \cos(\beta 2\pi f_m t) - \sin(2\pi f_c t) \sin(\beta 2\pi f_m t)]. \end{aligned}$$

The signal $s_{FM}(t)$ is nonperiodic unless $f_c = n f_m$, where n is a positive integer.

For the general case,

$$\begin{aligned} s_{FM}(t) &= \operatorname{Re} \left\{ A_c e^{j[2\pi f_c t + \beta \sin(2\pi f_m t)]} \right\} \\ &= \operatorname{Re} \left\{ s_e(t) e^{j2\pi f_c t} \right\}, \end{aligned}$$

where the complex envelope of the FM signal is described by

$$s_e(t) = A_c e^{j\beta \sin(2\pi f_m t)}$$

Observation: Unlike $s_{FM}(t)$, $s_e(t)$ is periodic with period $1/f_m$.

Since $s_e(t)$ meets the Dirichlet conditions, we can compute its Fourier series, i.e.,

$$s_e(t) = \sum_{n=-\infty}^{\infty} c_n e^{j2\pi n f_m t},$$

where the Fourier series coefficients are given by

$$\begin{aligned} c_n &= \frac{1}{T} \int_{-T/2}^{T/2} s_e(t) e^{-j2\pi n f_m t} dt, & T &= 1/f_m \\ &= f_m \int_{-1/2 f_m}^{1/2 f_m} s_e(t) e^{-j2\pi n f_m t} dt \\ &= f_m \int_{-1/2 f_m}^{1/2 f_m} A_c e^{j\beta \sin(2\pi f_m t)} e^{-j2\pi n f_m t} dt \\ &= A_c f_m \int_{-1/2 f_m}^{1/2 f_m} e^{j[\beta \sin(2\pi f_m t) - 2\pi n f_m t]} dt. \end{aligned}$$

Let $x = 2\pi f_m t$.

Then, $dt = \frac{1}{2\pi f_m} dx$

and $c_n = \frac{A_c}{2\pi} \int_{-\pi}^{\pi} e^{j[\beta \sin x - nx]} dx$
 $= A_c J_n(\beta),$

where $J_n(\beta) \equiv \frac{1}{2\pi} \int_{-\pi}^{\pi} e^{j[\beta \sin x - nx]} dx$ is the Bessel function of the first kind of order n .

Therefore,

$$s_e(t) = A_c \sum_{n=-\infty}^{\infty} J_n(\beta) e^{j2\pi n f_m t}$$

and the FM tone waveform is described by

$$s_{FM}(t) = A_c \sum_{n=-\infty}^{\infty} J_n(\beta) \cos[2\pi(f_c + n f_m)t].$$

In the frequency domain,

$$\begin{aligned} S_{FM}(f) &= F\{s_{FM}(t)\} \\ &= F\left\{A_c \sum_{n=-\infty}^{\infty} J_n(\beta) \cos[2\pi(f_c + nf_m)t]\right\} \\ &= A_c \sum_{n=-\infty}^{\infty} J_n(\beta) F[\cos[2\pi(f_c + nf_m)t]] \\ &= A_c \sum_{n=-\infty}^{\infty} \frac{J_n(\beta)}{2} [\delta(f + f_c + nf_m) + \delta(f - f_c - nf_m)] \end{aligned}$$

Average power of the FM waveform:

Across a 1 ohm resistor, the power of the FM waveform is $P = A_c^2 / 2$

But,

$$P = \frac{A_c^2}{2} \sum_{n=-\infty}^{\infty} J_n^2(\beta)$$

is also the power of the FM waveform.

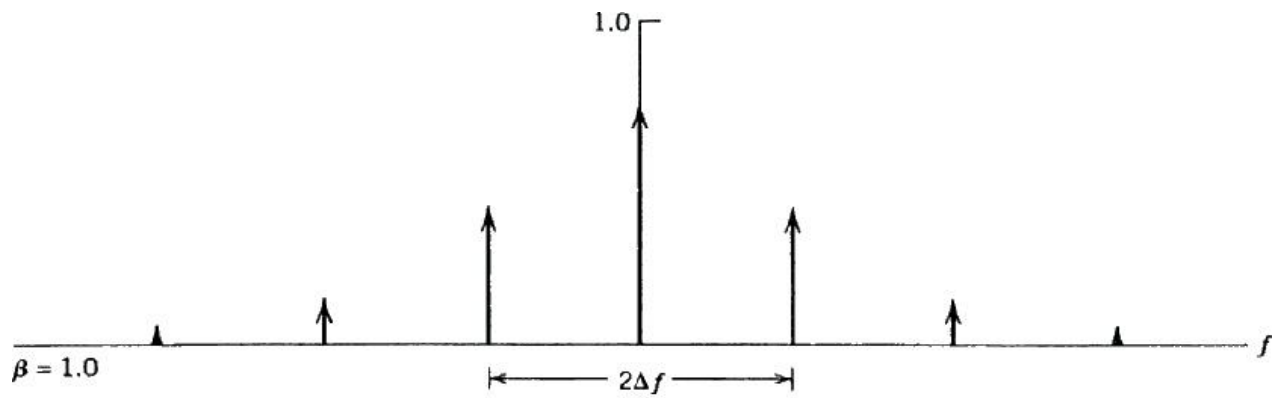

(a)

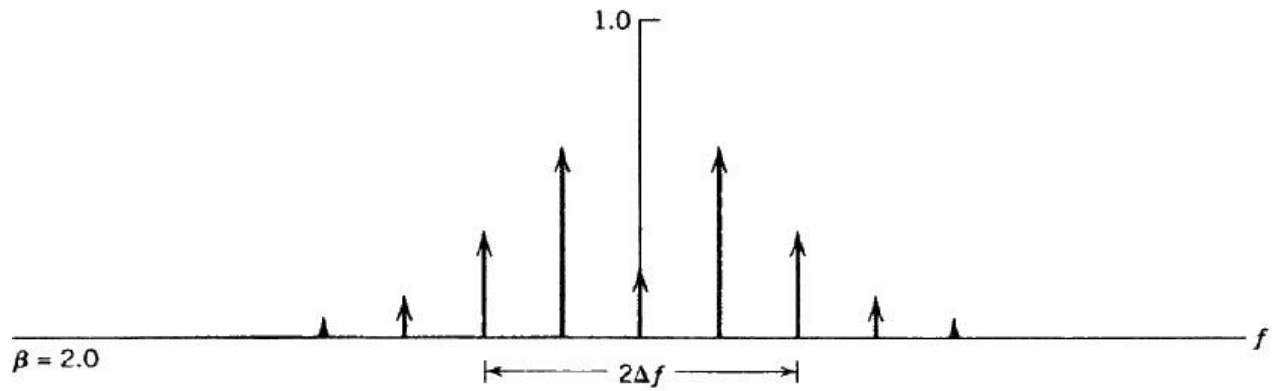

(b)

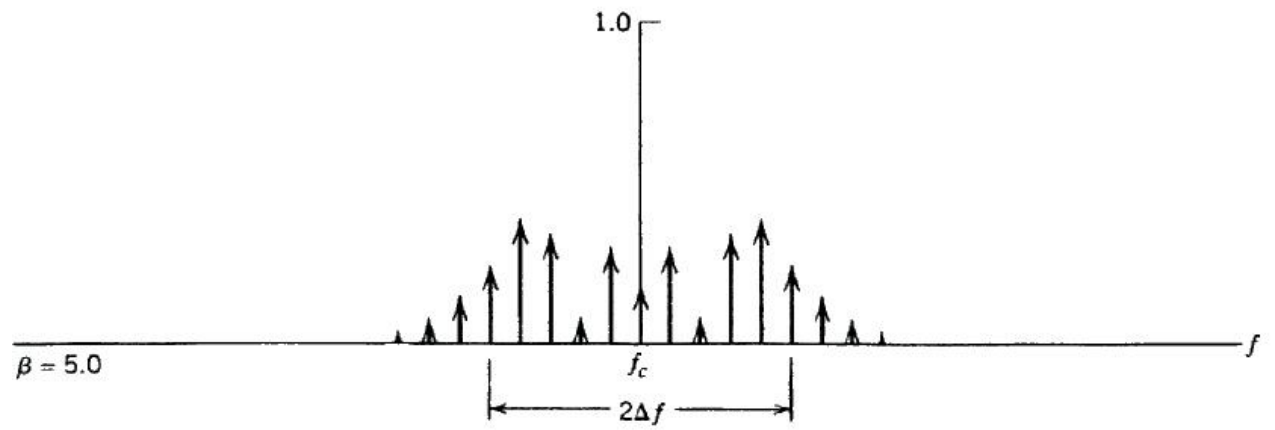

(c)

Let us now take a look at the properties of the Bessel function.

$$1. \quad J_n(\beta) = (-1)^n J_{-n}(\beta)$$

$$2. \quad \sum_{n=-\infty}^{\infty} J_n^2(\beta) = 1$$

Hence, the average power of an FM tone is $A_c^2 / 2$.

Suppose β is small, i.e., $0 < \beta \leq 0.3$, then

- $J_0(\beta) \cong 1$
- $J_1(\beta) \cong \beta / 2$
- $J_n(\beta) \cong 0, \quad n \geq 2$

Under the assumption that β is small, the Fourier series representation of the FM waveform can be simplified to three terms.

Thus, for β small, the FM tone may be described by

$$\begin{aligned} s_{FM}(t) &\cong A_c \left\{ \cos(2\pi f_c t) + \frac{\beta}{2} \cos(2\pi(f_c + f_m)t) - \frac{\beta}{2} \cos(2\pi(f_c - f_m)t) \right\} \\ &= A_c \cos(2\pi f_c t) + A_c \frac{\beta}{2} \cos(2\pi(f_c + f_m)t) - A_c \frac{\beta}{2} \cos(2\pi(f_c - f_m)t) \end{aligned}$$

In the frequency domain,

$$\begin{aligned} S_{FM}(f) &\cong \frac{A_c}{2} [\delta(f + f_c) + \delta(f - f_c)] - \frac{A_c \beta}{4} [\delta(f + f_c - f_m) + \delta(f - f_c + f_m)] \\ &\quad + \frac{A_c \beta}{4} [\delta(f + f_c + f_m) + \delta(f - f_c - f_m)] \end{aligned}$$

A plot of the magnitude spectrum of the FM tone with β small is shown below

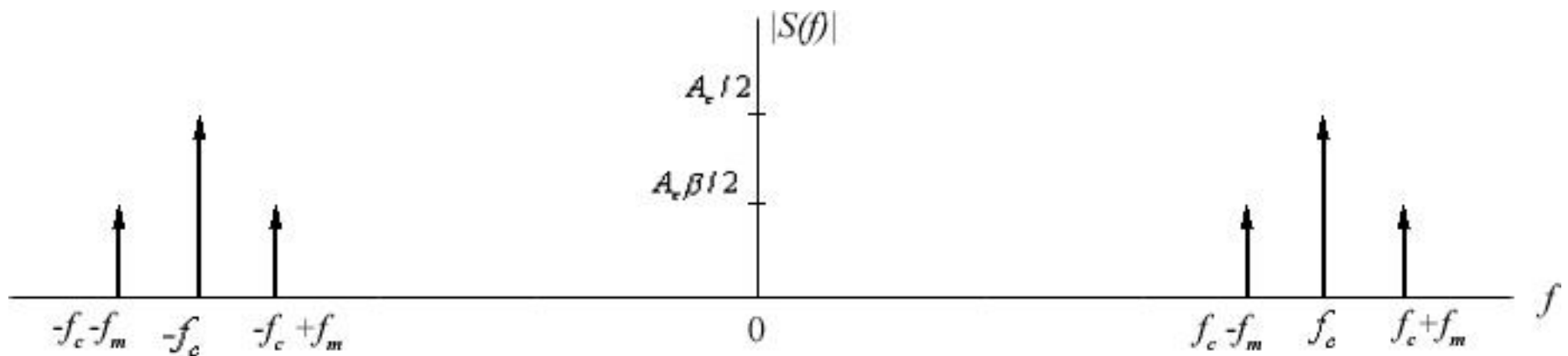

The time domain FM waveform can be represented in phasor form as follows:

$$\vec{S}_{FM} = A_c \angle 0^\circ + \frac{1}{2} A_c \beta \angle 2\pi f_m t + \frac{1}{2} A_c \beta \angle -2\pi f_m t + \pi$$

For arbitrary $t = t_0$, and small β , we can illustrate graphically the phasor representation and arrive at some conclusion.

The following figure shows an example of the phasor representation

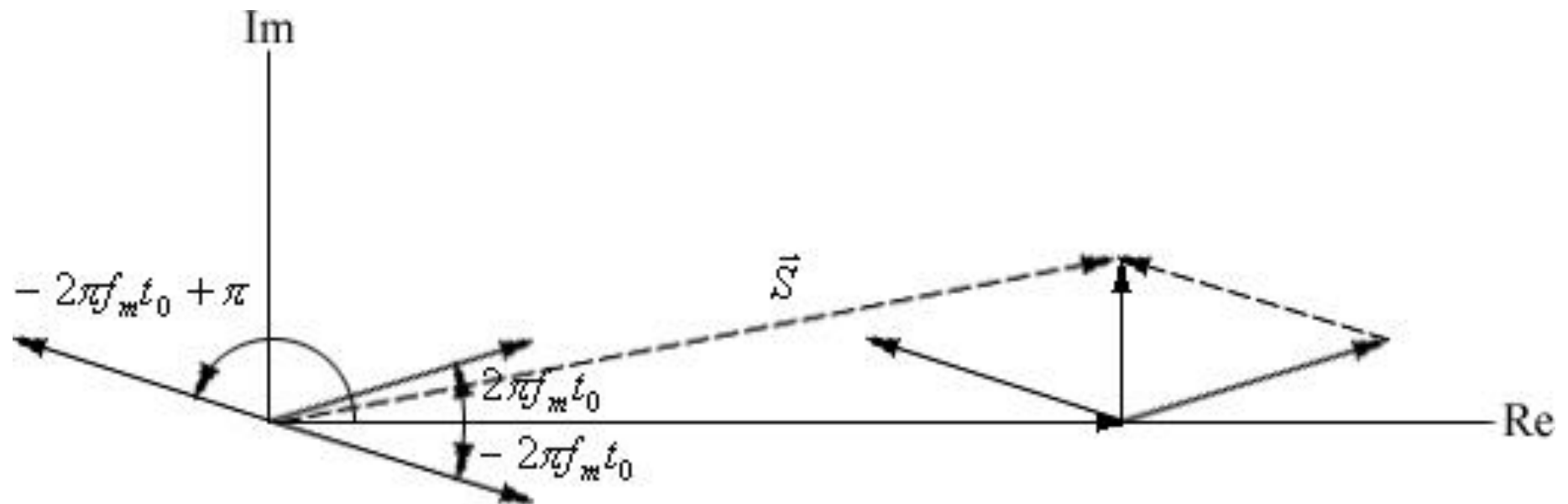

Observation:

The resultant phasor \vec{S}_{FM} , has magnitude $|\vec{S}_{FM}| \cong A_c$ and is out of phase with respect to the carrier phasor $A_c \angle 0^\circ$.

Analytically,

$$\vec{S}_{FM} = A_c + \frac{1}{2} A_c \beta [\cos(2\pi f_m t) + j \sin(2\pi f_m t) + \cos(-2\pi f_m t + \pi) + j \sin(-2\pi f_m t + \pi)]$$

But,
$$\cos(-2\pi f_m t + \pi) = \cos(2\pi f_m t) \cos \pi + \underbrace{\sin \pi}_0 \sin(2\pi f_m t)$$

$$= -\cos(2\pi f_m t)$$

and
$$\sin(-2\pi f_m t + \pi) = -\sin(2\pi f_m t) \cos \pi + \underbrace{\sin \pi}_0 \cos(2\pi f_m t)$$

$$= \sin(2\pi f_m t)$$

Consequently, the resultant phasor is given by

$$\vec{S}_{FM} = A_c + jA_c \beta \sin(2\pi f_m t)$$

The magnitude of the resultant may be approximated by

$$\begin{aligned} |\vec{S}_{FM}| &= \sqrt{A_c^2 + A_c^2 \beta^2 \sin^2(2\pi f_m t)} \\ &\cong A_c \left[1 + \frac{1}{2} \beta^2 \sin^2(2\pi f_m t) \right], \end{aligned}$$

since $(1+x)^n \cong 1+nx, \quad |nx| < 1$

Finally, the magnitude and phase of the resultant are found to be

$$\left| \vec{S}_{FM}(t) \right| = A_c \left[1 + \frac{\beta^2}{4} - \frac{\beta^2}{4} \cos(4\pi f_m t) \right]$$

$$\angle \vec{S}_{FM} = \phi_{\vec{S}}(t) = \tan^{-1} [\beta \sin(2\pi f_m t)]$$

Observation:

- For an FM tone, the spectral lines sufficiently away from the carrier may be ignored because their contribution (amplitude) is very small.

FM Transmission Bandwidth:

For an FM **tone**, as β becomes large $J_n(\beta)$ has significant lines only for

$$|n| \leq \beta = k_f A_m / f_m = \Delta f / f_m.$$

\therefore All significant lines are contained in the frequency range

$$f_c \pm \beta f_m = f_c \pm \Delta f,$$

where Δf is the peak frequency deviation.

Let β be small, i.e., $0 < \beta \leq 0.3$, then

$$J_0(\beta) \gg J_n(\beta), n \neq 0$$

which means that only the first pair of spectral lines is significant, i.e., the significant lines are contained in the range $f_c \pm f_m$

Observation: The previous analysis of an FM **tone** suggests that

1. For large β the FM bandwidth is $B_{FM} = 2\Delta f$
2. For small β the FM bandwidth is $B_{FM} = 2f_m$.

In general, the FM transmission bandwidth may be approximated by

$$\begin{aligned} B_T &\cong 2\Delta f + 2f_m \\ &= 2\Delta f (1 + f_m / \Delta f) \\ &= 2\Delta f (1 + 1 / \beta) \end{aligned}$$

This is known as the Carson's rule.

Observation: Carson's rule underestimates the transmission bandwidth by about 10%.

Alternative definition of FM **tone** transmission bandwidth:

A band of frequencies that keeps all spectral lines whose magnitudes are greater than 1% of the unmodulated carrier amplitude A_c , i.e.,

$$B_T = 2n_{\max} f_m,$$

where $n_{\max} = \max\{n: |J_n(\beta)| > 0.01\}$.

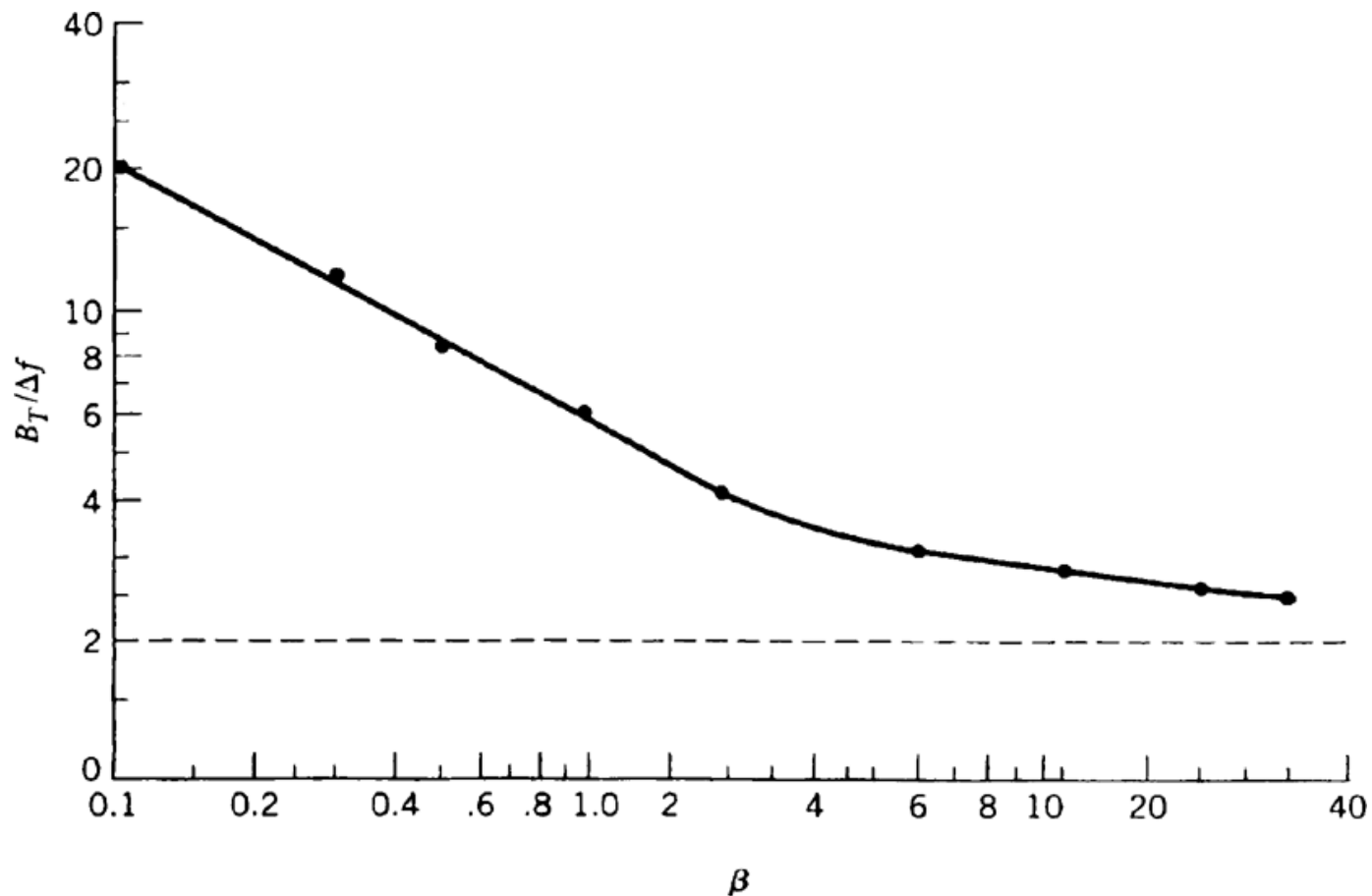

General Case:

Let an arbitrary message signal $m(t)$ have bandwidth W_m .

Define the peak frequency deviation and the deviation ratio by

$$\Delta f \hat{=} k_f \max_t \{|m(t)|\}$$

and

$$D \hat{=} \Delta f / W_m.$$

Then Carson's rule can be used to define the transmission bandwidth of an arbitrary FM signal, i.e., when $m(t)$ is arbitrary.

Specifically, the FM transmission bandwidth can be defined by

$$\begin{aligned} B_T &\cong 2\Delta f + 2W_m \\ &= 2\Delta f (1 + W_m / \Delta f) \\ &= 2\Delta f (1 + 1/D) \end{aligned}$$

Example: In commercial FM in the US, $\Delta f = 75$ kHz, $W_m = 15$ kHz.

Therefore, the deviation ratio is $D = 75 \text{ kHz} / 15 \text{ kHz} = 5$.

Using Carson's rule, the transmission bandwidth is

$$B_T = 2\Delta f (1 + 1/D) = 180 \text{ kHz},$$

Using the Universal curve, the transmission bandwidth is

$$B_T = 3.2\Delta f = 240 \text{ kHz}.$$

In practice, FM radio in the US uses a transmission bandwidth of $B_T = 200$ kHz.

Generation of FM

The frequency of the carrier can be varied by the modulating signal $m(t)$ directly or indirectly.

Direct generation of FM

If a very high degree of stability of the carrier frequency is not a concern, then we can generate FM directly using circuits without external crystal oscillators. Examples of this method are VCO's, varactor diode modulators, reactance modulators, Crosby modulators (modulators that use automatic frequency control), etc..

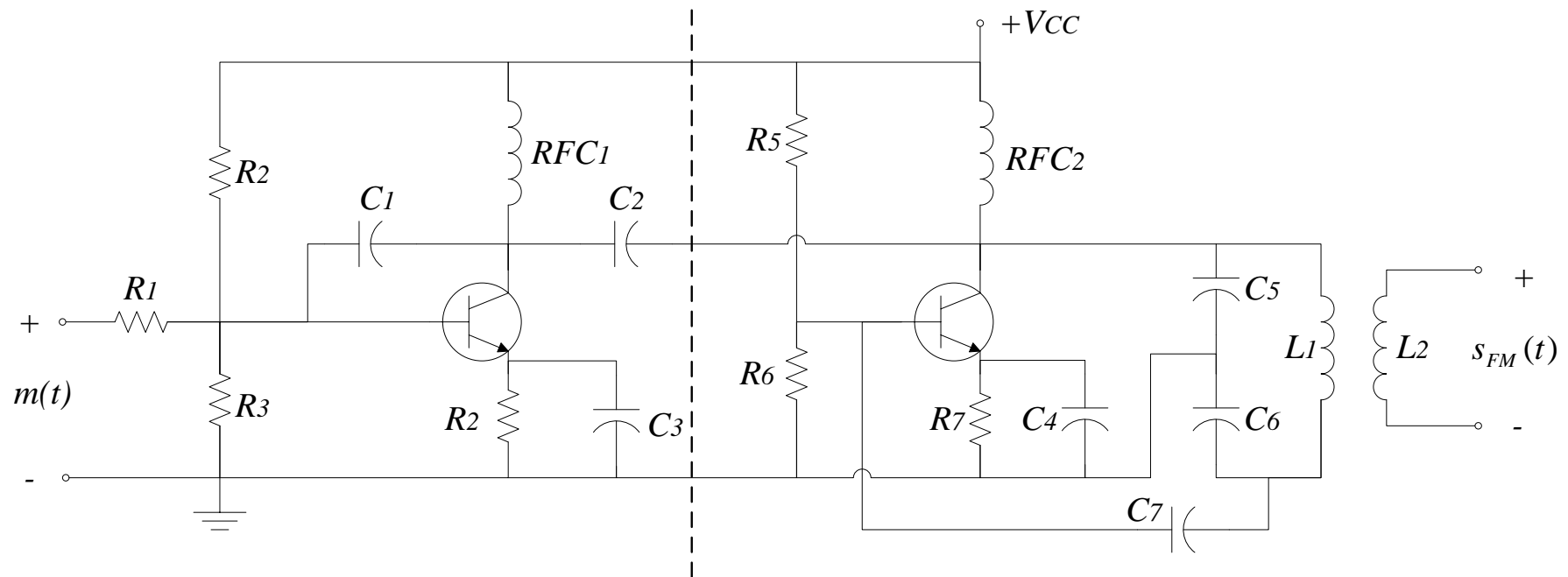

Indirect generation of FM

Commercial applications of FM (as established by the FCC and other spectrum governing bodies) require a high degree of stability of the carrier frequency. Such restrictions can be satisfied by using external crystal oscillators, a narrowband phase modulator, several stages of frequency multiplication and mixers.

Let us begin with the synthesis of narrow-band FM.

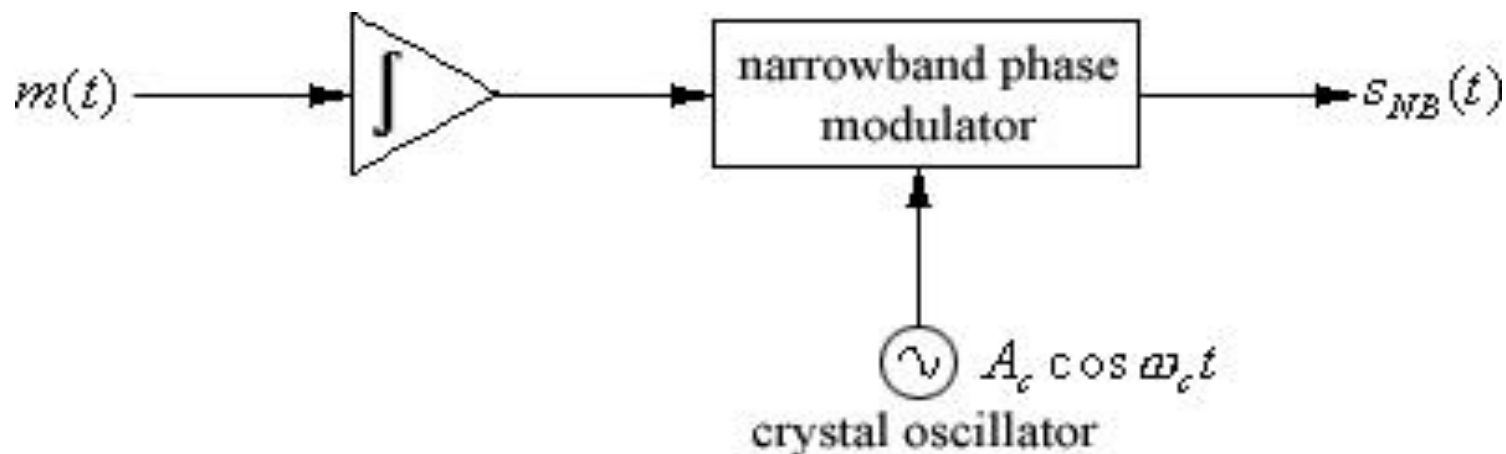

Narrowband frequency modulator

The narrow band FM signal is given by

$$s_{NB}(t) = A_c \cos \left[2\pi f_c t + 2\pi k_f \int_0^t m(\tau) d\tau \right]$$

with k_f (and thus Δf_{NB}) small

Let us now consider a technique to increase the FM signal bandwidth.

Let $s_{NB}(t)$ be input to a nonlinear device with transfer characteristic $y(t) = ax^n(t)$, where $x(t)$ is its input, namely.

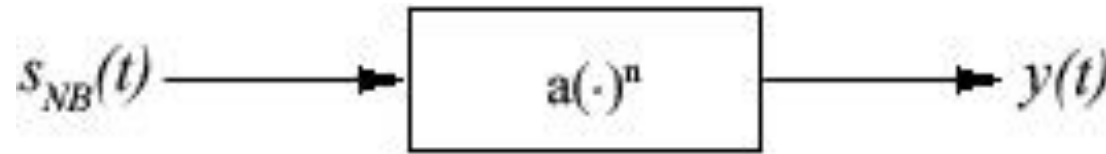

Nonlinear device.

Let $\theta_i(t) = 2\pi f_c t + 2\pi k_f \int_0^t m(\tau) d\tau$ then at the output of the nonlinear device, we observe

$$y(t) = aA_c^n \cos^n \theta_i(t)$$

Let us expand this last equation to infer the effect of this nonlinear device.

$\cos^n \theta_i(t)$ can be expanded as follows:

$$\begin{aligned}\cos^n \theta_i(t) &= \cos^2 \theta_i(t) \cos^{n-2} \theta_i(t) \\ &= \frac{1}{2} [1 + \cos 2\theta_i(t)] \cos^{n-2} \theta_i(t) \\ &= \frac{1}{2} \cos^{n-2} \theta_i(t) + \frac{1}{2} \cos 2\theta_i(t) \cos^{n-2} \theta_i(t)\end{aligned}$$

Likewise,

$$\cos^{n-2} \theta_i(t) = \frac{1}{2} \cos^{n-4} \theta_i(t) + \frac{1}{2} \cos 2\theta_i(t) \cos^{n-4} \theta_i(t)$$

Thus,

$$\cos^n \theta_i(t) = \frac{1}{2} \cos^{n-2} \theta_i(t) + \frac{1}{4} \cos 2\theta_i(t) \cos^{n-4} \theta_i(t) + \frac{1}{4} \cos^2 2\theta_i(t) \cos^{n-4} \theta_i(t)$$

Expanding the last term of the previous equality, we get

$$\cos^2 2\theta_i(t) \cos^{n-4} \theta_i(t) = \frac{1}{4} [1 + \cos 4\theta_i(t)] \cos^{n-4} \theta_i(t).$$

Rewriting the equation before the last one, we get

$$\begin{aligned}\cos^n \theta_i(t) &= \frac{1}{2} \cos^{n-2} \theta_i(t) + \frac{1}{4} \cos 2\theta_i(t) \cos^{n-4} \theta_i(t) \\ &\quad + \frac{1}{8} \cos^{n-4} \theta_i(t) + \frac{1}{8} \cos 4\theta_i(t) \cos^{n-4} \theta_i(t) \\ &= \frac{1}{2} \cos^{n-2} \theta_i(t) + \frac{1}{8} \cos^{n-4} \theta_i(t) + \frac{1}{4} \cos 2\theta_i(t) \cos^{n-4} \theta_i(t) \\ &\quad + \frac{1}{16} \cos 4\theta_i(t) \cos^{n-6} \theta_i(t) + \frac{1}{32} \cos 2\theta_i(t) \cos^{n-6} \theta_i(t) \\ &\quad + \frac{1}{32} \cos 6\theta_i(t) \cos^{n-6} \theta_i(t)\end{aligned}$$

The last term in the expansion of $\cos^n \theta_i(t)$ is given by

$$\frac{1}{2^{k-1}} \cos k\theta_i(t) \cos^{n-k} \theta_i(t).$$

Let n be an even number, then, when $k = n$, the last term is

$$\frac{1}{2^{n-1}} \cos n\theta_i(t)$$

If, on the other hand, n is an odd number, then when $k = n-1$, the last term is

$$\frac{1}{2^{n-2}} [\cos(n-1)\theta_i(t) \cos \theta_i(t)] = \frac{1}{2^{n-1}} \cos(n-2)\theta_i(t) + \frac{1}{2^{n-1}} \cos n\theta_i(t)$$

Therefore, the last term in the expansion of $\cos^n \theta_i(t)$ is

$$\frac{1}{2^{n-1}} \cos n\theta_i(t)$$

So, can be expanded as

$$y(t) = c_0 + c_1 \cos \theta_i(t) + c_2 \cos 2\theta_i(t) + \dots + a \frac{A_c^n}{2^{n-1}} \cos n\theta_i(t)$$

Example: Consider the cases when $n = 2$ and $n = 3$.

Let $n = 2$, then

$$y(t) = aA_c^2 \cos^2 \theta_i(t)$$

or

$$y(t) = aA_c^2 \left[\frac{1 + \cos 2\theta_i(t)}{2} \right] = \frac{aA_c^2}{2} + \frac{aA_c^2}{2} \cos 2\theta_i(t)$$

Let $n = 3$, then

$$\begin{aligned} y(t) &= aA_c^3 \left[\frac{1}{2} \cos 2\theta_i(t) + \frac{1}{2} \cos 2\theta_i(t) \cos \theta_i(t) \right] \\ &= aA_c^3 \left[\frac{1}{2} \cos \theta_i(t) + \frac{1}{2} \left\{ \frac{1}{2} \cos 3\theta_i(t) + \frac{1}{2} \cos \theta_i(t) \right\} \right] \\ &= \frac{3aA_c^3}{4} \cos \theta_i(t) + \frac{aA_c^3}{4} \cos 3\theta_i(t) \end{aligned}$$

Finally,

$$y(t) = c_0 + c_1 \cos\left(2\pi f_c t + 2\pi k_f \int_0^t m(\tau) d\tau\right) + c_2 \cos\left(4\pi f_c t + 4\pi k_f \int_0^t m(\tau) d\tau\right) \\ + \dots + a \frac{A_c^n}{2^{n-1}} \cos\left(2\pi n f_c t + 2\pi n k_f \int_0^t m(\tau) d\tau\right)$$

Let $y(t)$ be input to an ideal bandpass filter with unity gain, bandwidth wide enough to accommodate spectrum of wide band signal and center frequency nf_c , i.e.,

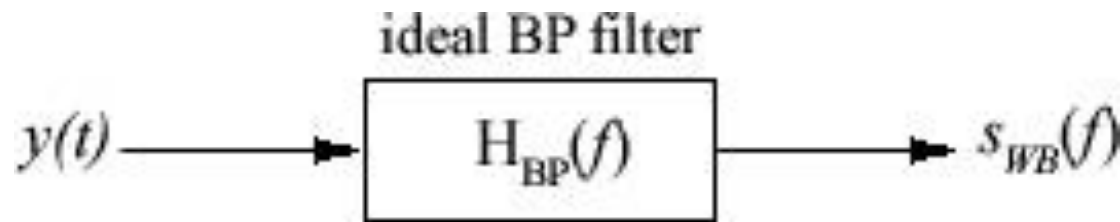

Ideal bandpass filter

Then,

$$S_{WB}(t) = \frac{aA_c^n}{2^{n-1}} \cos\left(2\pi n f_c t + 2\pi n k_f \int_0^t m(\tau) d\tau\right)$$

The instantaneous frequency of $s_{WB}(t)$ is

$$f_i(t) = nf_c + nk_f m(t)$$

Observations about $s_{WB}(t)$:

1. The carrier frequency is nf_c
2. The peak frequency deviation is $n\Delta f_{NB}$

These are the desired properties of the WB FM signal.

The overall frequency multiplier device is shown below:

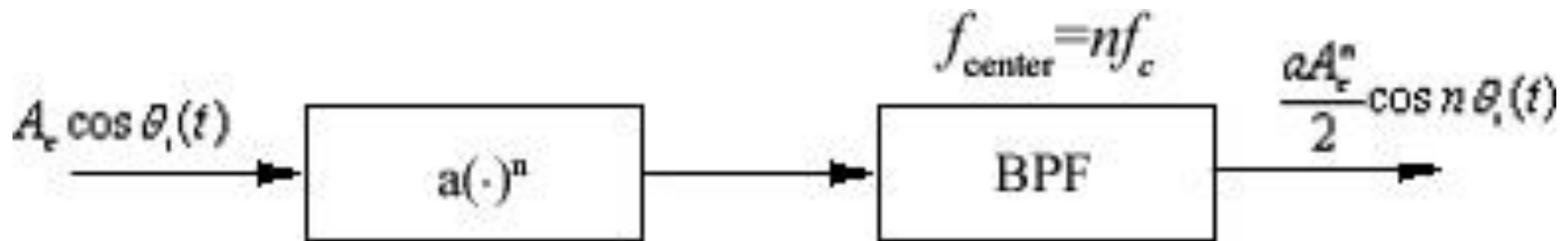

Complete frequency multiplier

Example: Noncommercial FM broadcast in the US uses the 88-90 MHz band and commercial FM broadcast uses the 90-108 MHz band (divided into 200 kHz channels). In either case $\Delta f = 75$ kHz. Suppose we target a station with $f_c = 90.1$ MHz. Then the indirect FM generation method suggested by Armstrong enables us to achieve our goals.

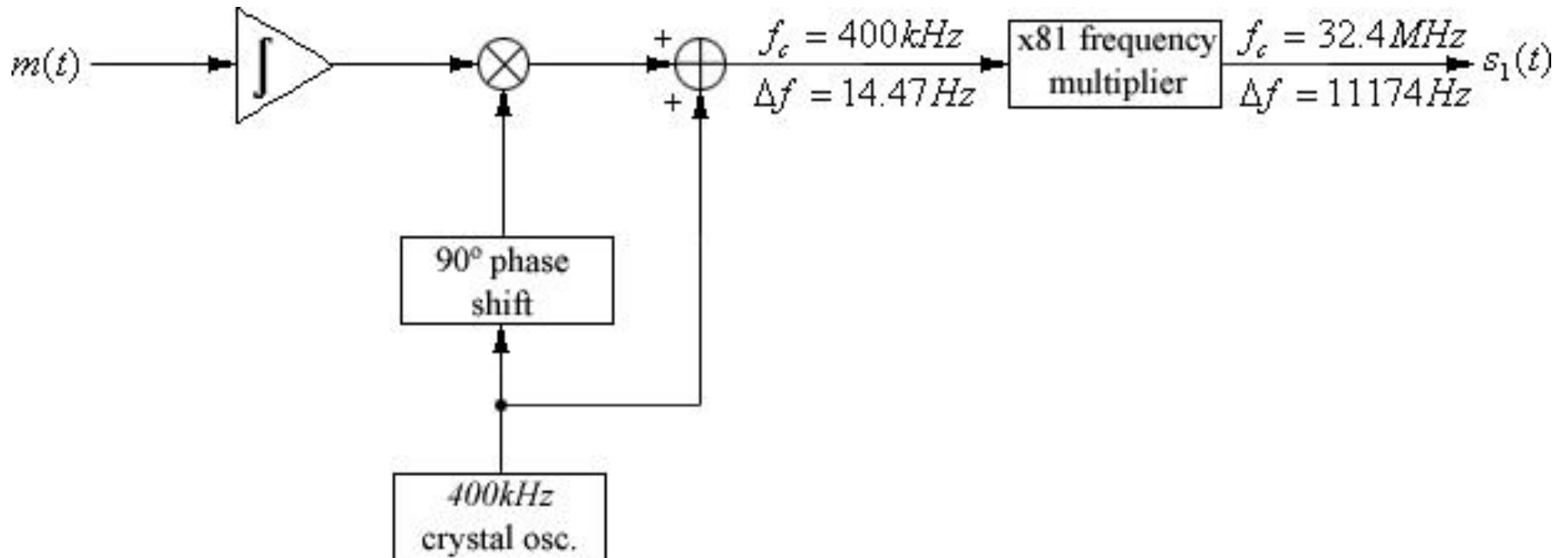

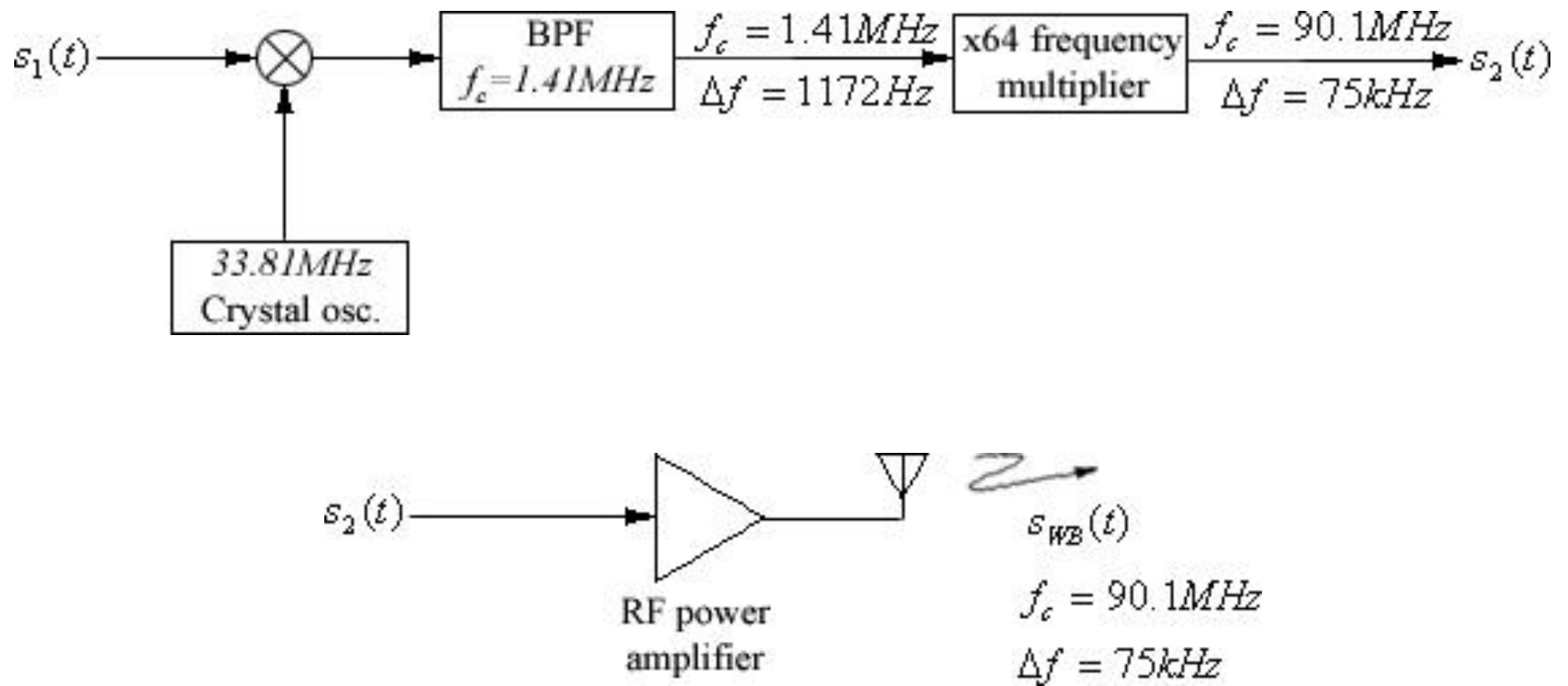

Armstrong indirect method of FM generation



Centurion
UNIVERSITY

Shaping Lives...
Empowering Communities...

THANK YOU.....