

# Chapter V

## **Application of Capacitors to Distribution System and Voltage Regulation**

# POWER FACTOR IMPROVEMENT

## Introduction:

- The electrical energy is almost exclusively generated, transmitted and distributed in the form of alternating current. Therefore, the question of power factor immediately comes into picture. M
- Most of the loads (e.g. induction motors , arc lamps) are inductive in nature and hence have low lagging power factor. The low power factor is highly undesirable as it causes an increase in current, resulting in an additional losses of active power in all the elements of power system from power station generator down to the utilization device.
- In order to ensure most favourable conditions for a supply system from engineering and economical standpoint , it is important to have power factor as close to unity as possible.

The cosine of angle between voltage and current in an a.c. circuit is known as **power factor**.

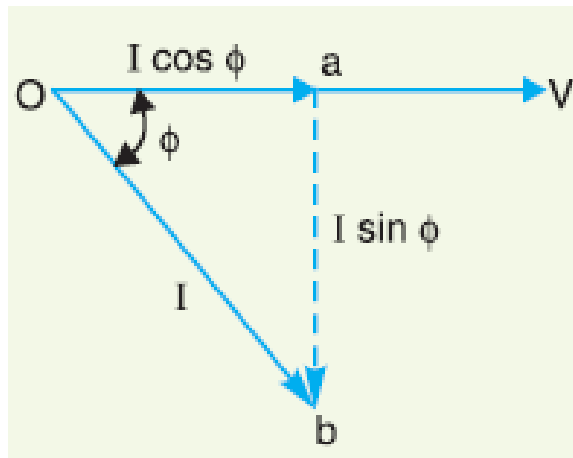

# Power Triangle

- $OA = VI \cos \phi$  and represents the *active power* in watts or kW  
 $AB = VI \sin \phi$  and represents the *reactive power* in VAR or kVAE  
 $OB = VI$  and represents the *apparent power* in VA or kVA

The following points may be noted form the power triangle :

- (i) The apparent power in an a.c. circuit has two components viz. active and reactive power at right angles to each other.

$$OB^2 = OA^2 + AB^2$$

or  $(\text{apparent power})^2 = (\text{active power})^2 + (\text{reactive power})^2$

or  $(\text{kVA})^2 = (\text{kW})^2 + (\text{kVAR})^2$

- (ii) Power factor,  $\cos \phi = \frac{OA}{OB} = \frac{\text{active power}}{\text{apparent power}} = \frac{\text{kW}}{\text{kVA}}$

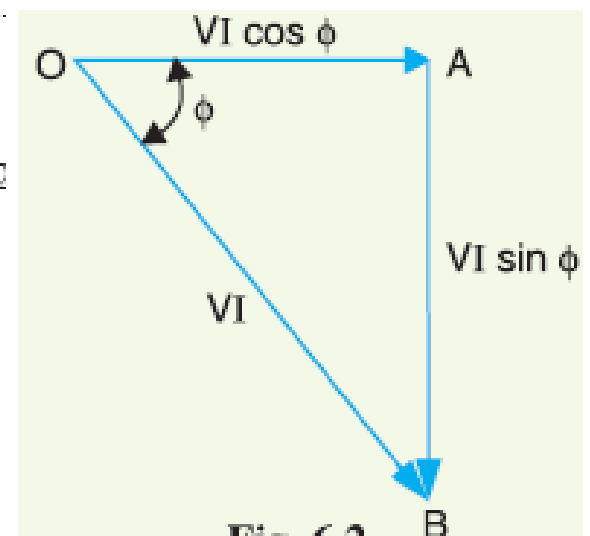
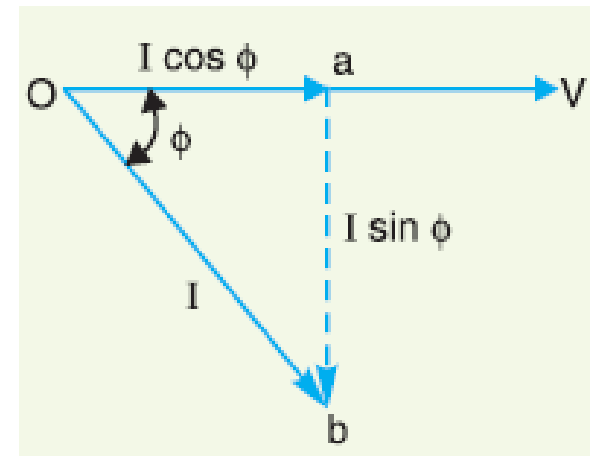

Fig. 6.2 B

(ii) Power factor,  $\cos \phi = \frac{OA}{OB} = \frac{\text{active power}}{\text{apparent power}} = \frac{\text{kW}}{\text{kVA}}$

Thus the power factor of a circuit may also be defined as the ratio of active power to the apparent power. This is a perfectly general definition and can be applied to all cases, whatever be the waveform.

(iii) The lagging\* reactive power is responsible for the low power factor. It is clear from the power triangle that smaller the reactive power component, the higher is the power factor of the circuit.

$$\text{kVAR} = \text{kVA} \sin \phi = \frac{\text{kW}}{\cos \phi} \sin \phi$$

$\therefore$   $\text{kVAR} = \text{kW} \tan \phi$

# Disadvantages of Low Power Factor

The power factor plays an importance role in a.c. circuits since power consumed depends upon this factor.

$$P = V_L I_L \cos \phi \quad \text{(For single phase supply)}$$
$$\therefore I_L = \frac{P}{V_L \cos \phi} \quad \dots(i)$$

$$P = \sqrt{3} V_L I_L \cos \phi \quad \text{(For 3 phase supply)}$$
$$\therefore I_L = \frac{P}{\sqrt{3} V_L \cos \phi} \quad \dots(ii)$$

It is clear from above that for fixed power and voltage, the load current is inversely proportional to the power factor. Lower the power factor, higher is the load current and *vice-versa*. A power factor less than unity results in the following disadvantages :

(i) **Large kVA rating of equipment.** The electrical machinery (*e.g.*, alternators, transformers, switchgear) is always rated in \*kVA.

Now, 
$$\text{kVA} = \frac{\text{kW}}{\cos \phi}$$

It is clear that kVA rating of the equipment is inversely proportional to power factor. The smaller the power factor, the larger is the kVA rating. Therefore, at low power factor, the kVA rating of the equipment has to be made more, making the equipment larger and expensive.

(ii) **Greater conductor size.** To transmit or distribute a fixed amount of power at constant voltage, the conductor will have to carry more current at low power factor. ~~The necessary~~

- 
- (iii) **Large copper losses.** The large current at low power factor causes more  $I^2R$  losses in all the elements of the supply system. This results in poor efficiency.
  - (iv) **Poor voltage regulation.** The large current at low lagging power factor causes greater voltage drops in alternators, transformers, transmission lines and distributors. This results in the decreased voltage available at the supply end, thus impairing the performance of utilisation devices. In order to keep the receiving end voltage within permissible limits, extra equipment (*i.e.*, voltage regulators) is required.
  - (v) **Reduced handling capacity of system.** The lagging power factor reduces the handling capacity of all the elements of the system. It is because the reactive component of current prevents the full utilisation of installed capacity.



# Power Factor Improvement

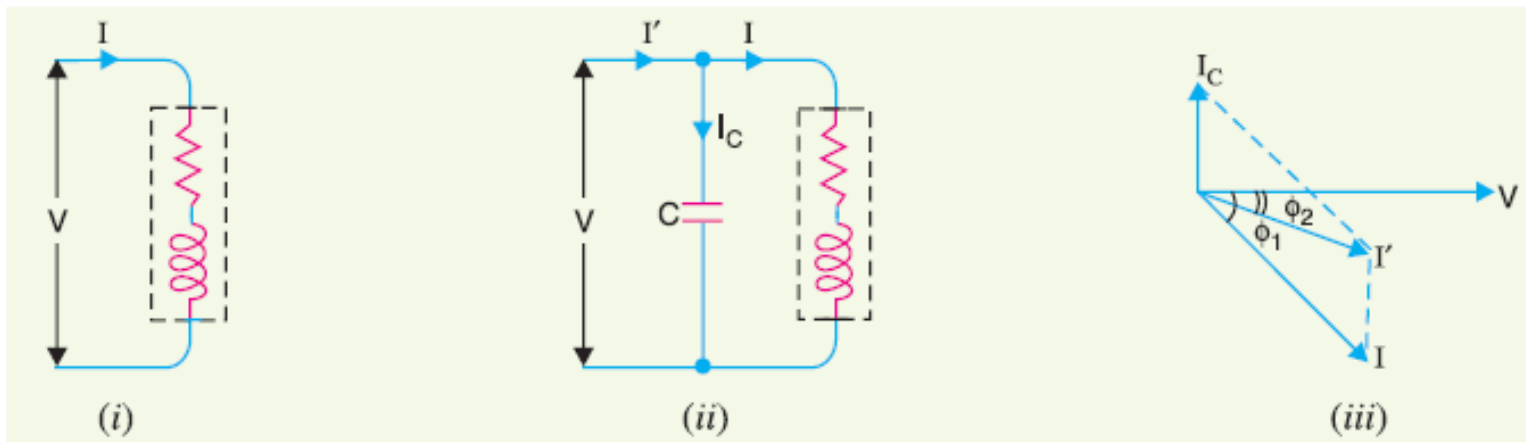

- (i) The circuit current  $I'$  after p.f. correction is less than the original circuit current  $I$ .
- (ii) The active or wattful component remains the same before and after p.f. correction because only the lagging reactive component is reduced by the capacitor.

$$\therefore I \cos \phi_1 = I' \cos \phi_2$$

- (iii) The lagging reactive component is reduced after p.f. improvement and is equal to the difference between lagging reactive component of load ( $I \sin \phi_1$ ) and capacitor current ( $I_C$ ) i.e.,

$$I' \sin \phi_2 = I \sin \phi_1 - I_C$$

- (iv) As  $I \cos \phi_1 = I' \cos \phi_2$

$$\therefore VI \cos \phi_1 = VI' \cos \phi_2 \quad \text{[Multiplying by } V \text{]}$$

Therefore, active power (kW) remains unchanged due to power factor improvement.

- (v)  $I' \sin \phi_2 = I \sin \phi_1 - I_C$

$$\therefore VI' \sin \phi_2 = VI \sin \phi_1 - VI_C \quad \text{[Multiplying by } V \text{]}$$

i.e., Net kVAR after p.f. correction = Lagging kVAR before p.f. correction – leading kVAR of equipment

# Power Factor Improvement Equipment

1. **Static capacitor.** The power factor can be improved by connecting capacitors in parallel with the equipment operating at lagging power factor. The capacitor (generally known as static\*\*

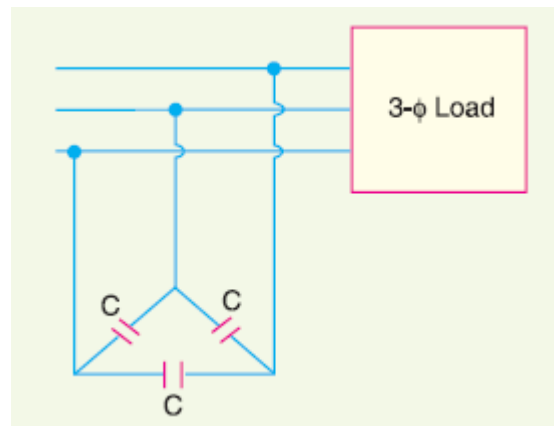

## Advantages

- (i) They have low losses.
- (ii) They require little maintenance as there are no rotating parts.
- (iii) They can be easily installed as they are light and require no foundation.
- (iv) They can work under ordinary atmospheric conditions.

## Disadvantages

- (i) They have short service life ranging from 8 to 10 years.
- (ii) They are easily damaged if the voltage exceeds the rated value.
- (iii) Once the capacitors are damaged, their repair is uneconomical.

**2. Synchronous condenser.** A synchronous motor takes a leading current when over-excited and, therefore, behaves as a capacitor. An over-excited synchronous motor running on no load is known as *synchronous condenser*. When such a machine is connected in parallel with the supply, it takes a leading current which partly neutralises the lagging reactive component of the load. Thus the power factor is improved.

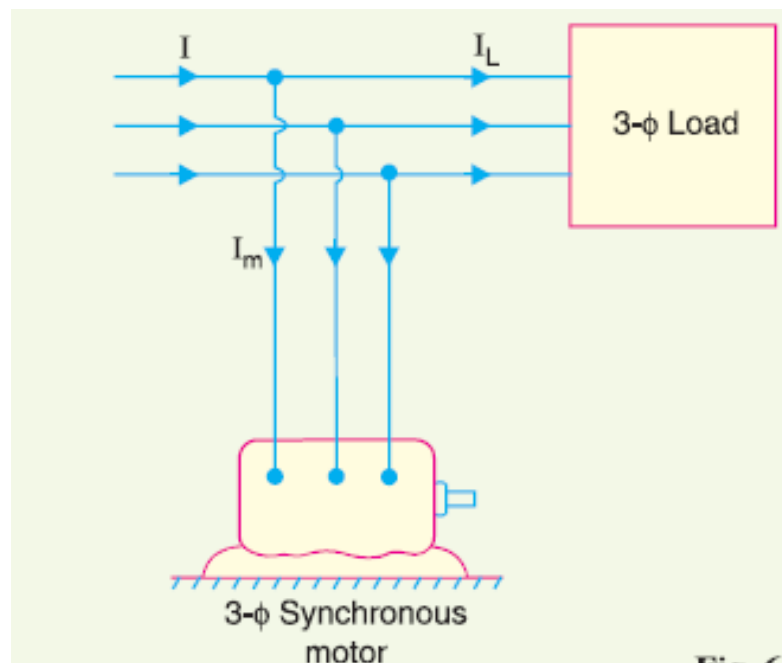

---

## Advantages

- (i) By varying the field excitation, the magnitude of current drawn by the motor can be changed by any amount. This helps in achieving stepless † control of power factor.
- (ii) The motor windings have high thermal stability to short circuit currents.
- (iii) The faults can be removed easily.

## Disadvantages

- (i) There are considerable losses in the motor.
- (ii) The maintenance cost is high.
- (iii) It produces noise.
- (iv) Except in sizes above 500 kVA, the cost is greater than that of static capacitors of the same rating.
- (v) As a synchronous motor has no self-starting torque, therefore, an auxiliary equipment has to be provided for this purpose.

# Calculations of Power Factor correction

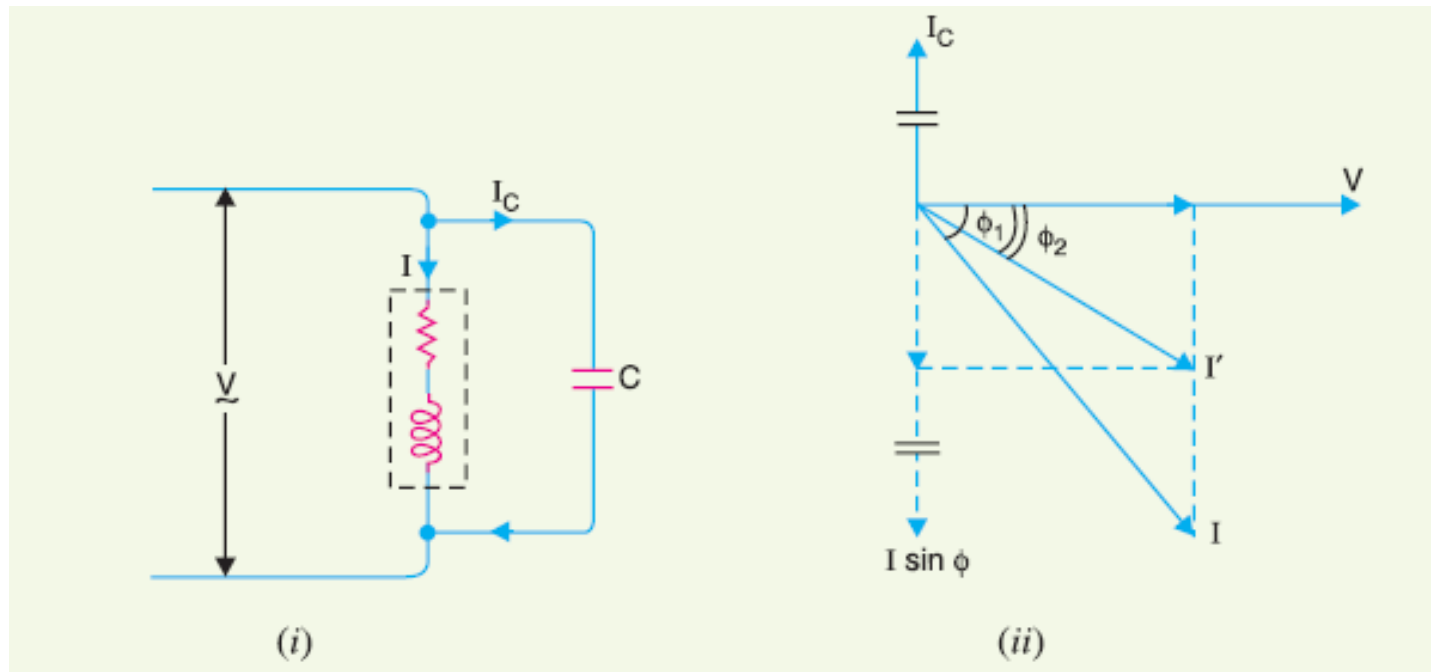

From the phasor diagram, it is clear that after p.f. correction, the lagging reactive component of the load is reduced to  $I' \sin \phi_2$ .

Obviously,  $I' \sin \phi_2 = I \sin \phi_1 - I_C$

or  $I_C = I \sin \phi_1 - I' \sin \phi_2$

$\therefore$  Capacitance of capacitor to improve p.f. from  $\cos \phi_1$  to  $\cos \phi_2$

$$= \frac{I_C}{\omega V}$$

$$\left( \because X_C = \frac{V}{I_C} = \frac{1}{\omega C} \right)$$

**Power triangle.** The power factor correction can also be illustrated from power triangle. Thus referring to Fig. 6.7, the power triangle  $OAB$  is for the power factor  $\cos \phi_1$ , whereas power triangle  $OAC$  is for the improved power factor  $\cos \phi_2$ . It may be seen that active power ( $OA$ ) does not change with power factor improvement. However, the lagging kVAR of the load is reduced by the p.f. correction equipment, thus improving the p.f. to  $\cos \phi_2$ .

Leading kVAR supplied by p.f. correction equipment

$$\begin{aligned}
 &= BC = AB - AC \\
 &= \text{kVAR}_1 - \text{kVAR}_2 \\
 &= OA (\tan \phi_1 - \tan \phi_2) \\
 &= \text{kW} (\tan \phi_1 - \tan \phi_2)
 \end{aligned}$$

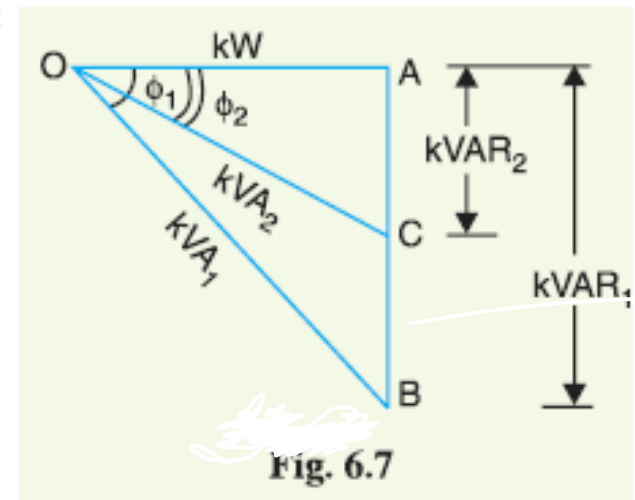

Knowing the leading kVAR supplied by the p.f. correction equipment, the desired results can be obtained.

## Nomogram for calculating Multiplication factor

$$kVA_r = kW (\tan \phi_e - \tan \phi_d)$$

$$kVA_r = kW \times MF$$

MF = multiplying factor

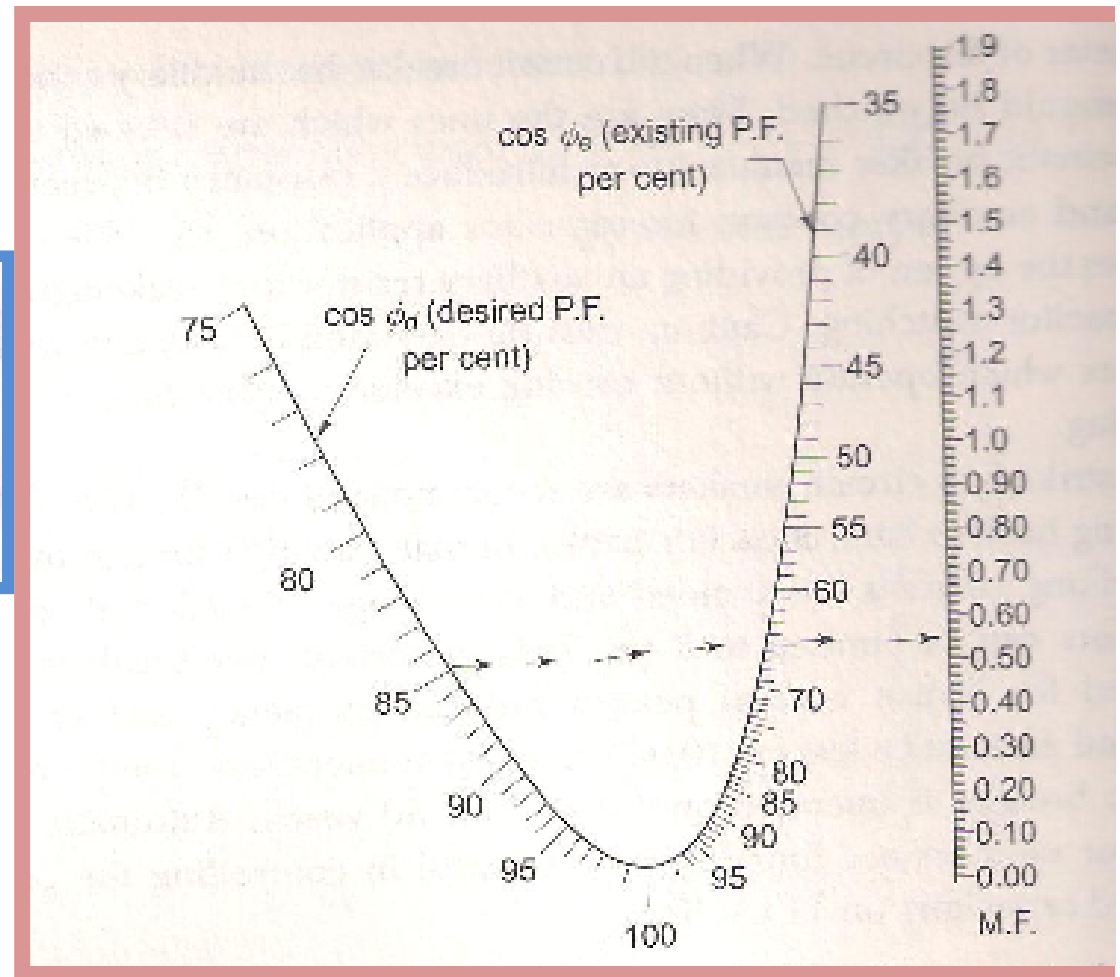

# Problem

A single phase motor connected to 400 V, 50 Hz supply takes 31.7A at a power factor of 0.7 lagging. Calculate the capacitance required in parallel with the motor to raise the power factor to 0.9 lagging.  $C = 94.3 \times 10^{-6} \text{ F} = 94.3 \mu\text{F}$

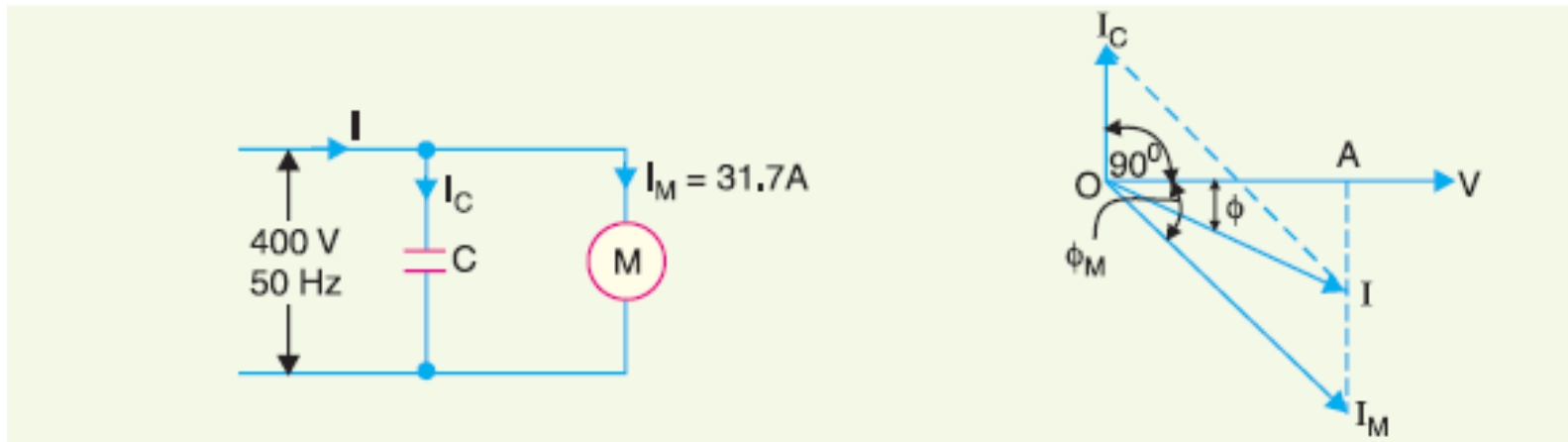



*A 3-phase, 5 kW induction motor has a p.f. of 0.75 lagging. A bank of capacitors is connected in delta across the supply terminals and p.f. raised to 0.9 lagging. Determine the kVAR rating of the capacitors connected in each phase.*

Leading kVAR taken by the condenser bank

$$\begin{aligned} &= P (\tan \phi_1 - \tan \phi_2) \\ &= 5 (0.8819 - 0.4843) = 1.99 \text{ kVAR} \end{aligned}$$

∴ Rating of capacitors connected in each phase

$$= 1.99/3 = \mathbf{0.663 \text{ kVAR}}$$

**Problem:**

The load on an installation is 800 kW, 0.8 lagging p.f. which works for 3000 hours per annum. The tariff is Rs 100 per kVA plus 20 paise per kWh. If the power factor is improved to 0.9 lagging by means of loss-free capacitors costing Rs 60 per kVAR, calculate the annual saving effected. Allow 10% per annum for interest and depreciation on capacitors.

**Solution.**

$$\text{Load, } P = 800 \text{ kW}$$

$$\cos \phi_1 = 0.8 \quad ; \quad \tan \phi_1 = \tan (\cos^{-1} 0.8) = 0.75$$

$$\cos \phi_2 = 0.9 \quad ; \quad \tan \phi_2 = \tan (\cos^{-1} 0.9) = 0.4843$$

Leading kVAR taken by the capacitors

$$= P (\tan \phi_1 - \tan \phi_2) = 800 (0.75 - 0.4843) = 212.56$$

**Annual cost before p.f. correction**

$$\text{Max. kVA demand} = 800/0.8 = 1000$$

$$\text{kVA demand charges} = \text{Rs } 100 \times 1000 = \text{Rs } 1,00,000$$

$$\text{Units consumed/year} = 800 \times 3000 = 24,00,000 \text{ kWh}$$

$$\text{Energy charges/year} = \text{Rs } 0.2 \times 24,00,000 = \text{Rs } 4,80,000$$

$$\text{Total annual cost} = \text{Rs } (1,00,000 + 4,80,000) = \text{Rs } 5,80,000$$

### Annual cost after p.f. correction

$$\text{Max. kVA demand} = 800/0.9 = 888.89$$

$$\text{kVA demand charges} = \text{Rs } 100 \times 888.89 = \text{Rs } 88,889$$

$$\text{Energy charges} = \text{Same as before } i.e., \text{Rs } 4,80,000$$

$$\text{Capital cost of capacitors} = \text{Rs } 60 \times 212.56 = \text{Rs } 12,750$$

$$\text{Annual interest and depreciation} = \text{Rs } 0.1 \times 12750 = \text{Rs } 1275$$

$$\text{Total annual cost} = \text{Rs } (88,889 + 4,80,000 + 1275) = \text{Rs } 5,70,164$$

$$\therefore \text{Annual saving} = \text{Rs } (5,80,000 - 5,70,164) = \text{Rs } 9836$$

# Real and Reactive Power Demand

The operating power from distribution system is composed of both active and reactive elements. The typical daily load curves (reactive and active power) for a 66kV feeder is given in Fig.

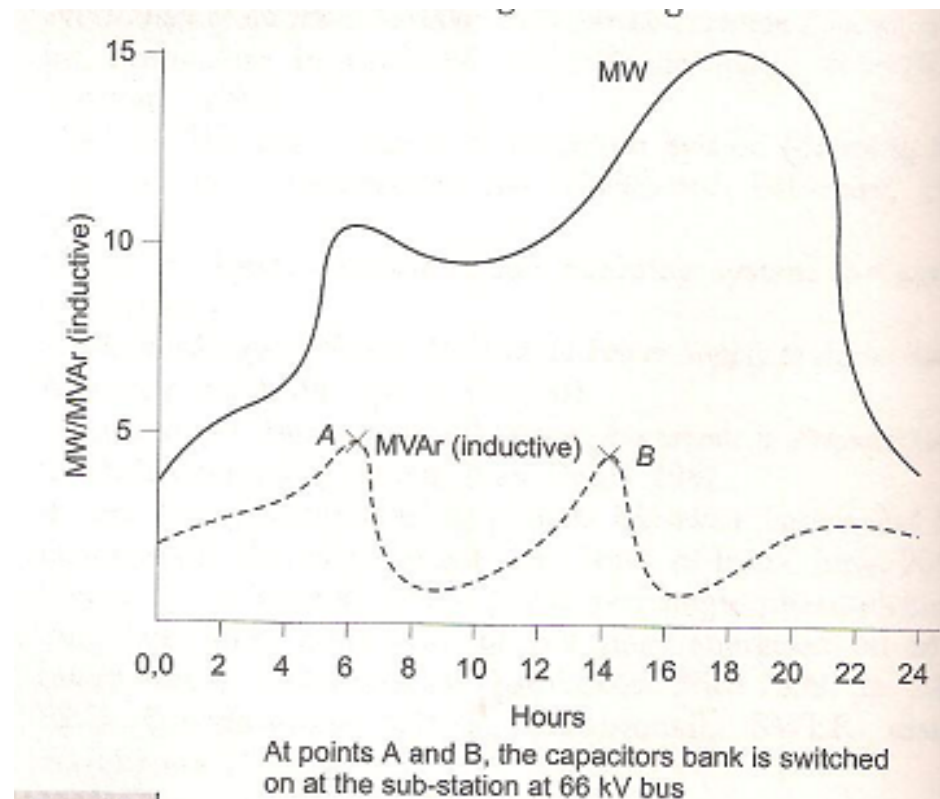

The reactive power is consumed by overhead lines, transformers and loads. Its proper generation and control is important for maintaining the network voltage under normal and abnormal power system operation and to reduce system losses.

The system voltage collapse due to lack of global control of reactive power flow during crucial grid has collapsed many times during the past few years due to lack of reactive power in the region.

Cost per kVAr of reactive power generation varies between 2 per cent and 4 per cent of per kW installed regulating controls. The system should be planned for carrying out suitable proportion of reactive energy.

## Reactive Power Consumption by lines:

- The distribution lines consume reactive power ( $I^2X$ ) depending upon the series reactance ( $X$ ) and load current ( $I$ ). The series reactance of line is proportional to the conductor self – inductance, which decreases as the spacing between conductors decreases.
- The minimum spacing is kept such as to prevent flash- over in foul weather conditions. According to a study of rural area , the average reactive power consumed by primary HT (11kV) and LT lines for each transformer at full-load is almost 1 per cent of transformer rating. The underground cable (11 kV and above) generate reactive power ( $I_c^2X_c$ ) depending upon the capacitive reactance ( $X_c$ ) and charging current ( $I_c$ ) at rated voltage.

## Reactive Power Consumption by lines:

- Increasing the line voltage at transformer and motors above the rated voltage will increase the consumption of reactive energy, the extent of which depends upon their designs. Generally, increase of 10% of the rated voltage will result in about 20% reduction of power factor.

# Reactive Power Consumption by Distribution Transformers

The reactive power consumption takes place in the series leakage and the shunt magnetizing reactances. The second component is voltage dependent, while the first component is proportional to the square of the transformer current. A completely unloaded transformer would be very inductive and has a very low power factor. The reactive power used by a transformer (up to 100 kVA capacity) at full load and at rated voltage is approximately 7-9 % of the rated power of the transformer. When unloaded, the amount of reactive power remains between 3 and 4 % of the rated power.



# Reactive Power Consumption by Loads

Loads have varying reactive power requirement. The low power factor can be a result of the equipment as in case of welders, or it can result from the operating conditions under which equipment is used as lightly loaded transformers and lightly loaded induction motors.

# Reactive Power Compensation and Voltage control

Mainly capacitors are used to develop reactive power near the point of consumption. For capacitor compensation at load, the user reaps the same advantage as the power utility for higher power factor on small scale.

Also, if each load is compensated, the power factor remains relatively constant since in plants, loads are switched on and off and the dangers of over – compensation do not exist.

Suitable capacitor banks at grid or main sub- station are desirable to feed reactive requirement of lines, transformers and domestic consumers, etc., who have no capacitors at terminals.

# Over Compensation

At the point of capacitors over-compensation, the voltage rises and capacitive kVAr will export, i.e. it will flow to reverse side of the load. Under certain conditions, dangerously high transient voltage may prevail on the power lines.

Also, torque surges of over 20 times the motor rating can be transmitted to the motor shaft under rapid restart conditions. Over-compensation at consumer premises is not generally desirable.

# Typical capacitor connection at Transformer

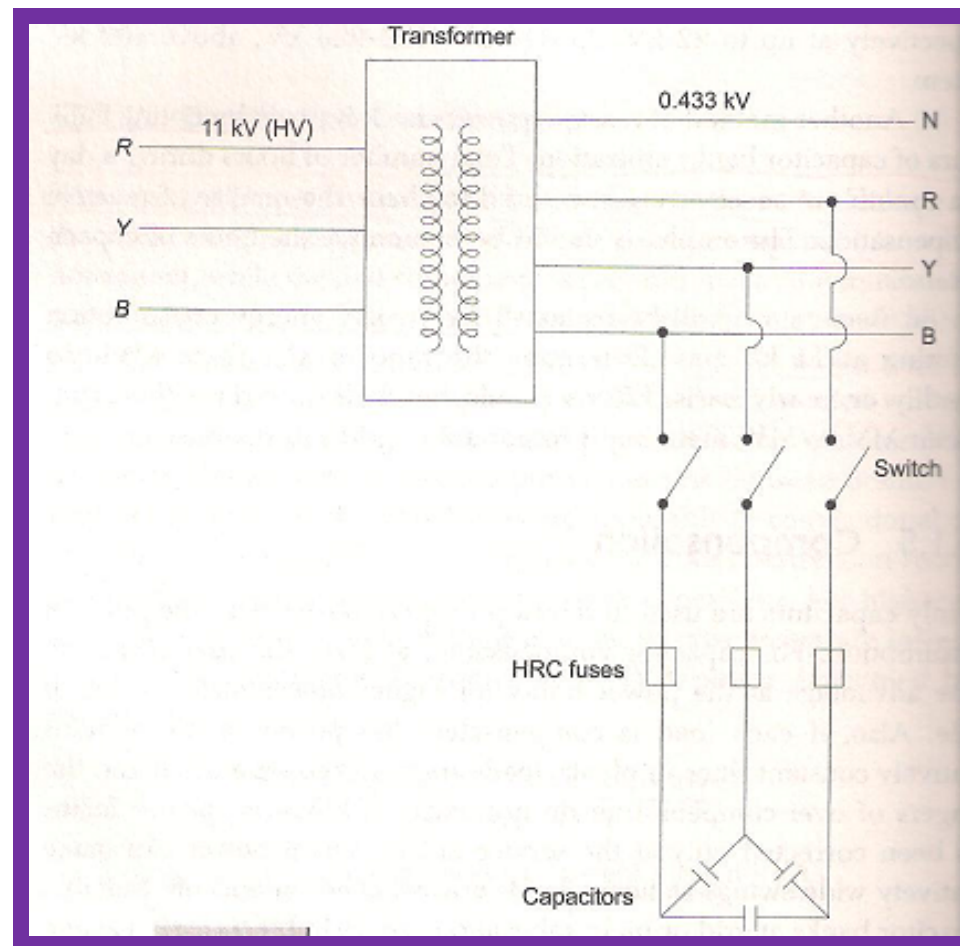

The minimum capacitor size can be connected permanently on secondary terminals, irrespective of load. This is the value of capacitance required to compensate the no-load magnetizing kV A of the transformer.

$$\text{Minimum Capacitor in KVAr} = \frac{\text{Transformer KVA} * \% \text{ Impedance}}{200}$$

# Typical scheme for automatic control of LT capacitors at distribution transformers

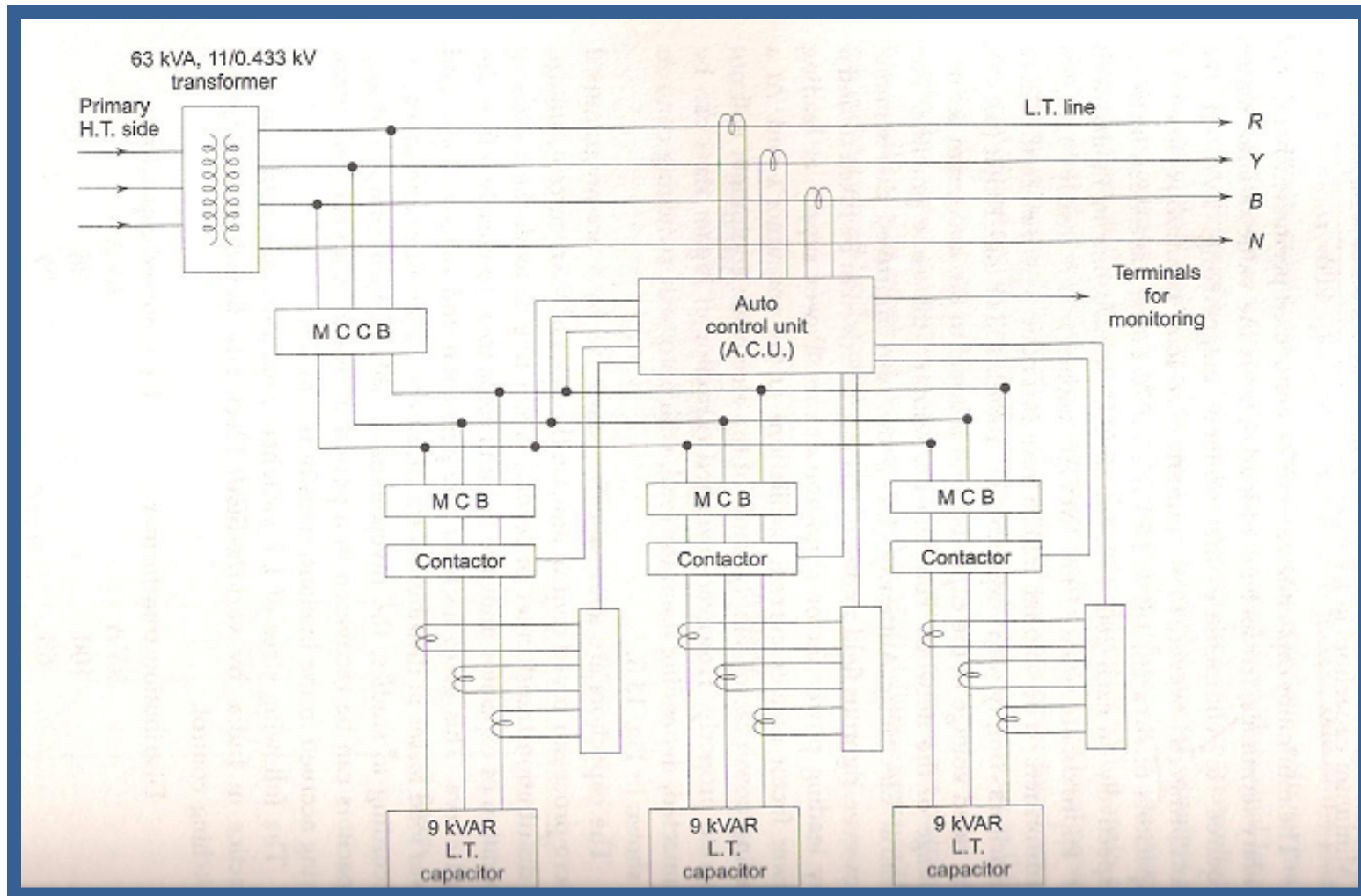

The minimum number of units required to limit the voltage increase to 10% can be calculated from the following equation for the grounded star bank.

$$N = 10 \left( 1 - \frac{1}{S} \right) - \frac{1}{S} + 1$$

Where N = Minimum number of parallel units in one series section  
S = Number of series sections in each phase.

# System Harmonics

With the increasing use of rectifiers, thyristor control shunt capacitors, etc. the harmonic generation can create problems with sensitive electronic equipment which can lead to errors in the protective gear, metering and control systems and also overload the capacitor banks besides causing resonance.

Reactors are sometimes needed to reduce the total current drawn by the capacitor banks if unduly large harmonics are present in the system voltage.



# The causes of harmonics in the power system

- Over-excited transformers
- Mercury rectifiers and thyristors
- Arc furnaces
- Slot harmonics of rotary machine
- Corona loss
- Large motors running at low slip, fluorescent lighting , T.V. and radio equipment
- System switching and load chocking

# Inrush Currents

When the capacitor banks are connected parallel to the supply, the initial charging current is said to be inrush current. The inrush current can be reduced by connecting the series damping reactors.

In the case of a single capacitor bank, the damping reactor is not normally required from the consideration of inrush currents at the time of switching.

The system reactance including the transformer to which the capacitor bank is installed is adequate enough to bring down the value of inrush currents within a safe limit of the capacitor or switchgear.

Even otherwise the duration of inrush current is so small, of the order of a few cycles only, that their effect can be ignored. When a number of capacitor banks are used in parallel, it may become necessary to use series reactors for limiting the inrush currents.

Assuming the severest condition of switching , the value of damping reactors in henries is given by

$$L \geq \frac{Q_2}{Q_1} \left( \frac{U_n^2}{Q_1 + Q_2} \right) \times 1.27 \times 10^{-6}$$

where,

$Q_1$  = capacity of the bank to be switched in MVar

$Q_2$  = capacity of the bank already switched in MVar

$U_n$  = rated voltage kV of the bank

The maximum peak inrush current can be approximately given by the formula

$$I_{\max} = I_{c1} \left( 1 + \frac{X_{c1}}{X_{l1}} \right)$$

Where,

$I_{c1}$  = capacitor's rated current (fundamental wave) rms

$X_{c1}$  = capacitor reactance (fundamental wave)

$X_{l1}$  = total inductive reactance of the system including capacitor bank (fundamental wave)

$$\text{Inrush current frequency } f_0 = \frac{1}{2\pi} \sqrt{\frac{1}{L_1 C_1} - \frac{R^2}{4L_1^2}}$$

Neglecting terms,  $R^2/4L_1^2$  because  $R$  is very small as compared to

$$f_0 \approx \frac{1}{2\pi} \sqrt{\frac{1}{L_1 C_1}}$$

$L_1$  is source inductance (H),  $C_1$  is capacitance of single bank (F) (s

In case of parallel banks, which are already energized, the inrush current is predominantly governed by the momentary discharge from the energized banks and since the impedance between the energized capacitor bank and the capacitor bank to be energized may be small, it may result in high peak inrush current. The maximum peak current is given by the expression

$$I_{\max} = \sqrt{2} E_{n1} \sqrt{\frac{C}{L}}$$
$$f_0 = \frac{1}{2\pi} \sqrt{\frac{1}{LC}}$$

C= equivalent capacitance of the circuit in H

L= equivalent series inductance between the energized banks and bank to be energized in H

$E_{n1}$  = line to neutral voltage

# Example

Two 11 kV capacitors banks, each of 2.5 MVar, are installed in parallel at a 132/11 kV sub-station. Calculate the value of the series damping reactor with each capacitor bank

# Solution

$$e(L) \geq \frac{121}{2.5 + 2.5} \times 1.27 \times 10^{-6}$$
$$\geq 31 \text{ micro henrys}$$

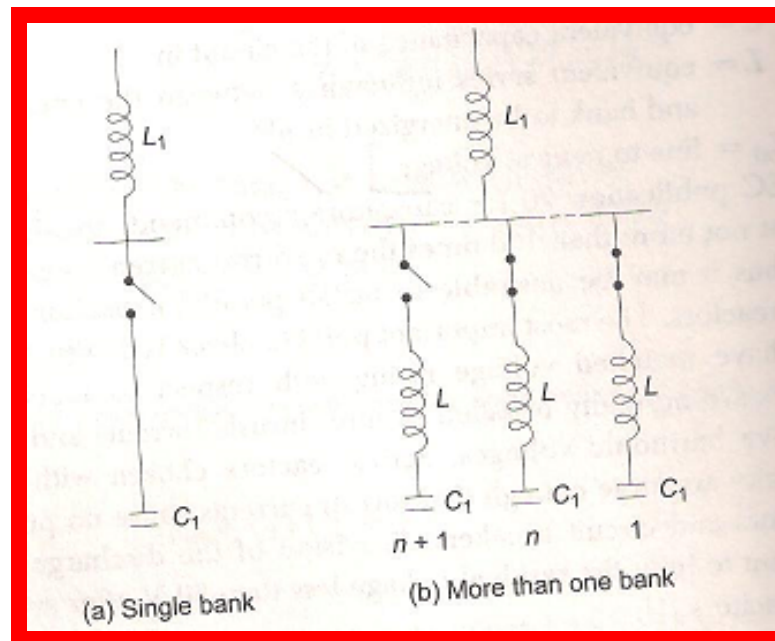



## Different Consumers Voltage Standards

<b>Load</b>	<b>Utilized Voltage</b>
10 kW	230 V
10-50 kW	415/230 V
50 kW-5 MW	11 kV
5 MW-30 MW	33-66 kV
30 MW-50MW	132 kV
Above 50 MW	220 kV

# Voltage Regulation

While studying the performance of a transmission line, it is desirable to determine its voltage regulation and transmission efficiency. We shall explain these two terms in turn.

- (i) **Voltage regulation.** When a transmission line is carrying current, there is a voltage drop in the line due to resistance and inductance of the line. The result is that receiving end voltage ( $V_R$ ) of the line is generally less than the sending end voltage ( $V_S$ ). This voltage drop ( $V_S - V_R$ ) in the line is expressed as a percentage of receiving end voltage  $V_R$  and is called voltage regulation.

*The difference in voltage at the receiving end of a transmission line \*\*between conditions of no load and full load is called **voltage regulation** and is expressed as a percentage of the receiving end voltage.*

Mathematically,

$$\% \text{ age Voltage regulation} = \frac{V_S - V_R}{V_R} \times 100$$

Obviously, it is desirable that the voltage regulation of a transmission line should be low *i.e.*, the increase in load current should make very little difference in the receiving end voltage.

(ii) **Transmission efficiency.** The power obtained at the receiving end of a transmission line is generally less than the sending end power due to losses in the line resistance.

*The ratio of receiving end power to the sending end power of a transmission line is known as the transmission efficiency of the line i.e.*

$$\begin{aligned} \% \text{ age Transmission efficiency, } \eta_T &= \frac{\text{Receiving end power}}{\text{Sending end power}} \times 100 \\ &= \frac{V_R I_R \cos \phi_R}{V_S I_S \cos \phi_S} \times 100 \end{aligned}$$

where  $V_R$ ,  $I_R$  and  $\cos \phi_R$  are the receiving end voltage, current and power factor while  $V_S$ ,  $I_S$  and  $\cos \phi_S$  are the corresponding values at the sending end.

# Methods of Voltage Control

# Importance Of Voltage Control

When the load on the supply system changes, the voltage at the consumers' terminals also changes. The variations of voltage at the consumer's terminals are undesirable and must be kept within prescribed limits for the following reasons :

(i) In case of lighting load, the lamp characteristics are very sensitive to changes of voltage. For instance, if the supply voltage to an incandescent lamp decreases by 6% of rated value, then illuminating power may decrease by 20%. On the other hand, if the supply voltage is 6% above the rated value, the life of the lamp may be reduced by 50% due to the rapid deterioration of the filament.

(ii) In case of power load consisting of induction motors, the voltage variations may cause erratic operation. If the supply voltage is above the normal, the motor may operate with a saturated magnetic circuit, with consequent large magnetising current, heating and low power factor. On the other hand, if the voltage is too low, it will reduce the starting torque of the motor considerably.

(iii) Too wide variations of voltage cause excessive heating of distribution transformers. This may reduce their ratings to a considerable extent.



It is clear from the above discussion that voltage variations in a power system must be kept to minimum level in order to deliver good service to the consumers. With the trend towards larger and larger interconnected system, it has become necessary to employ appropriate methods of voltage control.

# Methods Of Voltage Control

There are several methods of voltage control. In each method, the system voltage is changed in accordance with the load to obtain a fairly constant voltage at the consumer's end of the system. The following are the methods of voltage control in an a.c. power system:

- (i) By excitation control
- (ii) By using tap changing transformers
- (iii) Auto-transformer tap changing
- (iv) Booster Transformers
- (v) Induction Regulators
- (vi) By Synchronous Condensers

Method (i) is used at the generating station only whereas methods (ii) to (v) can be used for transmission as well as primary distribution systems. However, method

# Tap-Changing Transformers

Off load tap-changing transformer

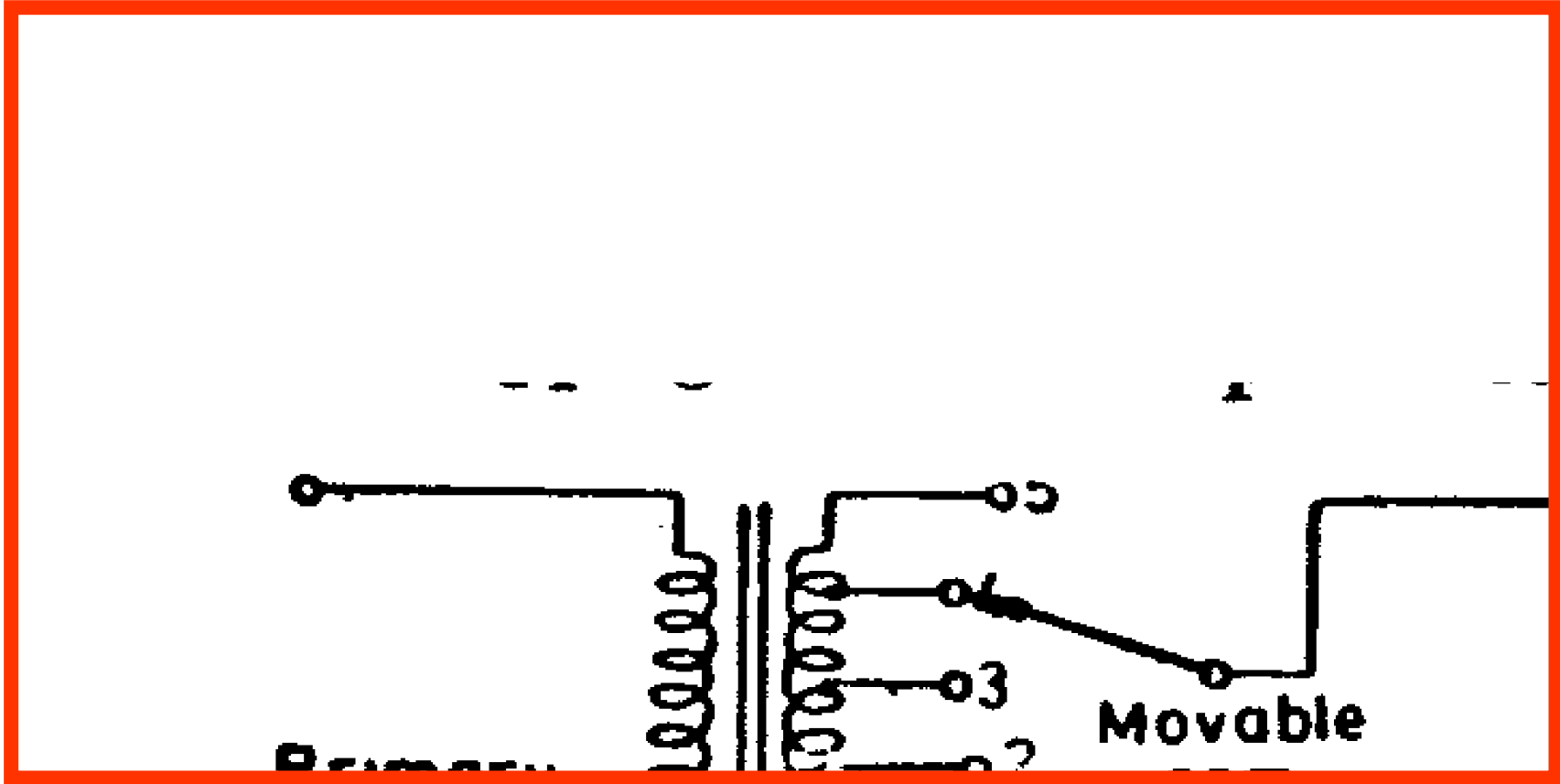

Figure shows the arrangement where a number of tappings have been provided on the secondary. As the position of the tap is varied, the effective number of secondary turns is varied and hence the output voltage of the secondary can be changed.

Thus referring to Fig. when the movable arm makes contact with stud 1, the secondary voltage is minimum and when with stud 5, it is maximum. During the period of light load, the voltage across the primary is not much below the alternator voltage and the movable arm is placed on stud 1. When the load increases,

the voltage across the primary drops, but the secondary voltage can be kept at the previous value by placing the movable arm on to a higher stud. Whenever a tapping is to be changed in this type of transformer, the load is kept off and hence the name off load tap. changing transformer





## ON load tap-changing transformer

