

DAIRY AND FOOD ENGINEERING

SUBJECT CODE: BTAP3207

**By
Dr. Gitanjali Behera**

**Department of agricultural Engineering, SoABE
Centurion University of Technology & Management
Paralakhemundi**

Lecture No:1

DAIRY DEVELOPMENT IN INDIA – BEFORE AND AFTER OPERATION FLOOD

1 Introduction

History of dairy development in India can be divided into two distinct phases: pre- and post-Operation Flood. The Defence Department under the British rule established military dairy farms to ensure the supply of milk and butter to the colonial army. The first of these farms was set up in Allahabad in 1913, followed by Bangalore, Ooty and Karnal. These farms were well maintained and used improved milch animals. Some herd improvement practices such as artificial insemination was also followed.

However, this did not have much impact on the civilian consumers. With the growth of the population in urban areas, consumers had to depend on milk vendors who kept cattle in these areas and sold their milk, often door-to-door. As a result, several cattle sheds came into existence in different cities, which led to environmental problems. As the main objective of the milk vendors was to maximize profit, they started increasing the lactation period. Consequently, these high-yielding cattle developed sterility problems, which considerably reduced the number of calvings. Once the cattle became unproductive, they were sold to slaughterhouses, thus systematically draining the country of its genetically superior breeds.

The onset of the Second World War gave momentum to private dairies with some modernized processing facilities. In the metros of the then Bombay, Calcutta, Madras and Delhi, and some large towns, processed milk, table butter and ice-cream were available, though on a limited scale. Polsons, Keventers and the Express Dairy were some of the pioneer urban processing dairies. However, these dairies were more concerned with cornering more milk and profit making than improving the breeds of milch animals. Therefore, despite some modernized processing facilities, dairying remained unorganized.

Modernization of the dairy industry became a priority for the government after first Five-Year Plan in 1951 and it was put in place. The goal was to provide hygienic milk to the country's growing urban population. At the outset, 'milk schemes' were set up in large cities. The government implemented programmes such as the Integrated Cattle Development Project (ICDP), Key Village Scheme (KVS) and several others to stimulate milk production. However, milk production remained more or less stagnant owing to the absence of a stable and remunerative market for milk producers. During the two decades between 1951 and 1970, the annual growth rate in milk production was just about 1% although the state governments tried out different policies to develop dairying. These strategies included establishing dairies run by their own departments, setting up cattle

colonies in urban areas and organizing milk schemes. Almost invariably, dairy processing plants were built in cities rather than in the milksheds where milk was produced, leading to establishment of cattle colonies in the then Bombay, Calcutta and Madras. These government projects found organizing rural milk procurement and running milk schemes economically extremely difficult. No attention was paid to create an organized system for procurement of milk, which was left to contractors and middlemen. Milk's perishable nature and relative scarcity gave the milk vendors considerable advantage.

The government-run dairy plants extended buffalo milk by reconstituting large quantities of relatively cheap, commercially imported milk powder to bring down the milk price. Consequently, the domestic milk production decreased. The government dairies were meeting barely one-third of the urban demand, while the rural milk producers squirmed in the clutches of the traders and the moneylenders. The establishment and prevalence of cattle colonies resulted in a major genetic drain on the rural milch animal population, which would never be replaced. City dairy colonies contributed to environmental degradation, while the rural producers derived no incentive in increasing milk production.

2 The Co-operative Movement

The strategy for organized dairy development in India was actually conceived in the late 1960s, within a few years after the establishment of National Dairy Development Board (NDDB) in 1965. NDDB was established by an Act of Parliament with the objectives of promoting dairy cooperatives, financing dairy infrastructure through loans and grants and providing technical and managerial support to the dairy cooperative societies. The Operation Flood programme (OFP) was conceived by the NDDB and endorsed by the government. However, in 1969, when the Government of India approved the OFP and its financing through the monetization of World Food Programme-gifted commodities, it was found that the statutes under which NDDB was registered did not provide for handling of government funds. Therefore, in 1970 the government established a public-sector company, the Indian Dairy Corporation (IDC). The IDC was given responsibility for receiving the project's donated commodities, testing their quality, their storage and transfer to user dairies as well as receiving the dairies' payments. Thus the financial and promotional aspects were the responsibility of the IDC while the entire technical support for OFP was provided by NDDB.

OFP was set up with the objectives to enhance milk production, increase the rural income and to ensure reasonable price to the farmers for the milk they produce. OFP was implemented in three phases. The first phase (1970-1980) was financed by the sale of 1,26,000 MT of skimmed milk powder (SMP) and 42,000 MT of butter oil gifted by the European Union (then European Economic Community – EEC) through the World Food Programme. The programme involved organizing dairy cooperatives at the village level, creating the physical and institutional infrastructure for milk procurement, processing, marketing and production

enhancement services at the union level and establishing dairies in India's major metropolitan cities. The main thrust was to set up dairy cooperatives in India's best milksheds, linking them with the four main cities of Bombay, Calcutta, Delhi and Madras, in which a commanding share of the milk market was to be captured. Thus, eighteen of India's premier milksheds were linked with consumers in India's four major metropolitan cities. In achieving that goal, the first phase of Operation Flood laid the foundation for India's modern dairy industry, an industry that would ultimately meet the country's need for milk and milk products.

Operation Flood's Phase II (1981-85) integrated the Indian Dairy Association-assisted dairy development projects being implemented in some Indian states into the overall programme. About US\$ 150 million was provided by the World Bank, with the balance of project financing obtained in the form of commodity assistance (2,16,584 MT of SMP, 62,402 MT of butter oil and 16,577 MT of butter) from the EEC. The milksheds increased from 18 to 136 and 290 urban markets expanded the outlets for milk. A self-sustaining system of 43,000 village cooperatives covering 4.25 million milk producers was established by the end of 1985. Domestic milk powder production in the established dairies increased from 22,000 tons in the pre-project year to 140,000 tons by 1989.

Phase III (1985-1996) of Operation Flood enabled dairy cooperatives to expand and strengthen the infrastructure required to procure and market increasing volumes of milk. It was funded by a World Bank credit of about US\$ 365 million and Rs. 226.5 crore worth of food aid (75,000 MT of SMP and 25,000 MT of butter oil/butter) from the EEC. Veterinary first-aid health care services, feed and artificial insemination services for cooperative members were extended, along with intensified member education. More emphasis was given to research and development in animal health and animal nutrition. To avoid any duplication in their activities or overlap of functions, IDC and NDDB were eventually merged into a newly constituted NDDB by an Act of Parliament passed in October, 1987. The Act designated the NDDB as an institution of national importance and accorded it the same autonomy of operation that it had been bestowed with earlier.

India currently has 133349 village dairy cooperatives federated into 177 milk unions and 15 federations that procured on an average 25.1 million litres of milk every day. These village dairy cooperatives have nearly 13.9 million farmers as members (www.nddb.org, 2008-09 figures). These cooperatives form part of the National Milk Grid which today links the milk producers in villages throughout India with consumers in over 700 towns and cities bridging the gap between the seasonal and regional variation in the availability of milk while at the same time ensuring a remunerative returns to the producers and quality milk and milk products at a reasonable price to the consumers. The future thrust areas of NDDB include strengthening the cooperative business, enhancing productivity, improving quality and building a National Information Network.

Lecture 2

Introduction to dairy and food Engineering

Different forms of milk

Market milk, Pasteurized milk, Sterilized milk, Homogenized milk, Soft-curd milk, Flavored milk, Vitaminized milk, Irradiated milk, Mineralized milk, Frozen concentrated milk

Fermented milk

- a. Natural butter milk
- b. Cultured butter milk
- c. Acidophilus milk
- d. Yoghurt

Standardized milk, Reconstituted milk, Recombined milk, Toned milk, Double toned milk, Humanized milk

Importance of milk in national scenario

- Presently India is the largest producer of milk in the world with an annual milk production of over 120 million tons.
- India has about **three times** as many dairy animals as the USA, over 80 percent being kept in herds of 2 to 8 animals.
- **Annual milk yield per dairy animal in India is about one tenth of that achieved in the USA and about one fifth of the yield of a grass-fed New-Zealand dairy cow.**
- A peculiar feature in our country is the wide variation between regions in respect of consumption of milk.

Milk Production in India

Year	Production (Million Tonnes)	Per capita avail. (g/day)
1991-92	55.7	178
1995-96	66.2	197
2000-01	80.6	220
2005-06	97.1	241
2006-07	100.9	246
2007-08	104.8	252
2008-09	108.5	258
2010-11	>120	281

Source: Department of Animal Husbandry, Dairying & Fisheries, Ministry of Agriculture, Govt. of India (May, 2010), Dr. S. Ayappan (Convocation address at OUAT on 28/07/2012)

- ✓ In 2001-02 India became the world leader in milk production.
- ✓ Recommended value of milk consumption is 250-450 g. (Minimum recommended by NIN is 80 to 310g/capita-day.
- ✓ Per-capita availability in India was only 114 g in 1975.\
- ✓ Punjab: 600 g, Haryana: 550 g, Orissa: 43 g.

Species contribution in India (in %)

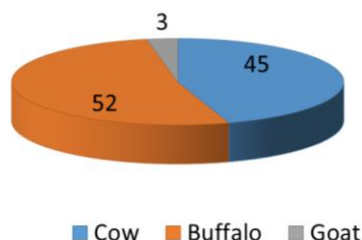

Species contribution in World (1999)

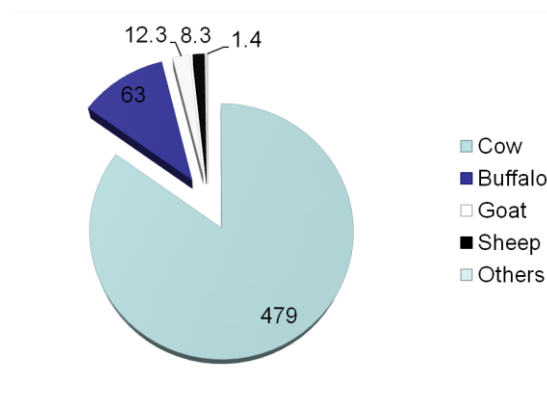

Total milk production in 1999: 564 million tonnes

Still there is scope of improvement in dairy sector

Low milk yielding capacity of average Indian cow

Shortage of feed and fodder

Lack of organised milk production and collection, restricted transport facilities (especially refrigerated)

Shortage of processing and marketing organizations

Poor quality milk, wide spread adulteration and lack of quality consciousness among the majority of consumers have aggravated the situation.

World Top 10 Cow's Milk Producing Countries in 2008 (Tonnes)			
	2006	2007	2008
USA	82,463,031	84,189,067	86,178,896
India	41,148,000	43,481,000	44,100,000*
China	32,257,300	35,574,326	35,853,665

Russian Federation	31,186,154	31,914,914	32,117,427
Germany	27,995,000	28,402,772	28,656,256
Brazil	26,185,564	26,944,064	27,752,000*
France	24,194,707	24,373,700	24,516,320
New Zealand	15,172,464	15,618,288	15,216,840
UK	14,316,000	14,023,000	13,719,000
Poland	11,982,393	12,096,005	12,425,300
World	558,826,488	571,403,458	578,450,488

Daily per capita milk consumption in some developing countries of the world (1995-96).

Country	Consumption, g
India	197
Bangladesh	71
Pakistan	245
Iraq	182
Iran	180
Israel	577
Japan	172

LECTURE 3

PROPERTIES OF MILK

(Important constituents of milk, Important properties of milk, Why these properties are important for us, Selection of metals for dairy industry)

IMPORTANT CONSTITUENTS OF MILK

The different constituents of milk can be shown as in Fig. 1

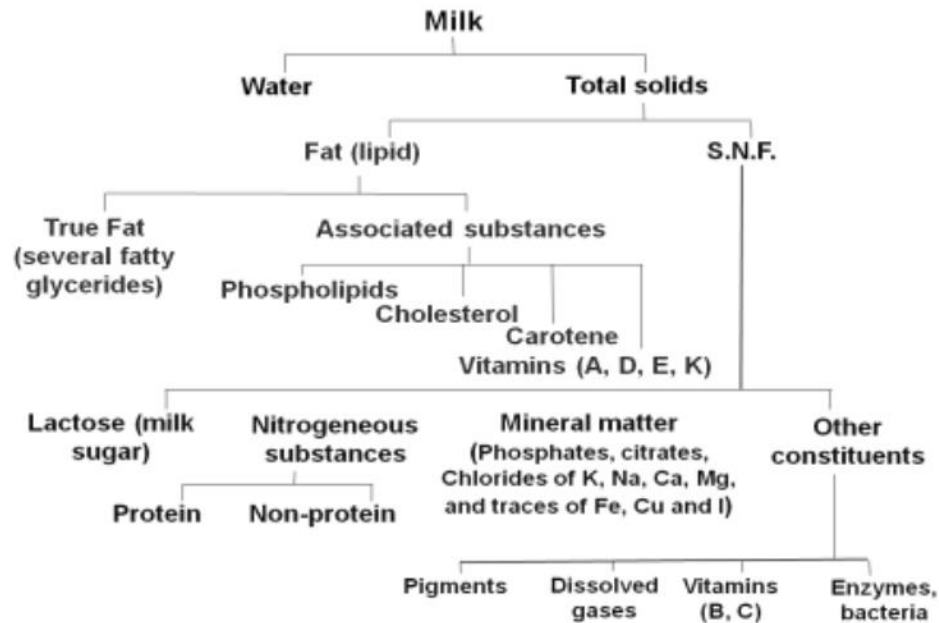

Fig. 1 Constituents of milk

Remember.....

- Milk contains all essential amino acids in fairly large quantities.
- It is an excellent source of Ca and P, both of which together with vit D are essential for bone formation.
- It is a good source of vit A (provided the cow is given sufficient green feed and fodder), vit D (provided the cow is exposed to enough sunlight), thiamine, riboflavin, etc. But milk is deficient in vit C.
- Milk fat, besides giving energy contains significant amount of essential fatty acids (linoleic and arachidonic), which give the characteristic flavor.
- Lactose (carbohydrate) provides energy. It also helps to establish a mild acidic reaction in the intestine (which checks the growth of proteolytic bacteria and facilitates assimilation).

The composition of milk varies with many factors, the most important of them being the species and breed of the animal. Table 1 gives an idea of the variations in major constituents of milk.

Table 1 Variation in major constituents of different milk

Source of Milk	Water	Fat	Protein	Lactose	Ash
Buffalo	84.2	6.6	3.9	5.2	0.8
Camel	86.5	3.1	4.0	5.6	0.8
Cow (Indian)	86.07	4.9	3.42	4.91	0.7
Cow (Foreign)	86.6	4.6	3.4	4.9	0.7
Goat	86.5	4.5	3.5	4.7	0.8
Human	87.7	3.6	1.8	6.8	0.1
Skim milk	90.6	0.1	3.6	5.0	0.7
Butter milk	91.0	0.4	3.4	4.5	0.7

Factors affecting composition of milk

- Species
- Breed: In general breeds giving more amount of milk yield a lower percentage of fat.
- Individuality
- Interval of milking (Longer interval implies more milk with a lower fat test).
- Completeness of milking: If the cow is completely milked the test is normal, or else, the test is lower.
- Irregularity of milking
- Disease and abnormal conditions
- Portion of milking: Fore-milk is low in fat content (less than 1%), while strippings are the highest close to 10%. Other milk constituents are slightly affected on a fat free basis.
- Stage of lactation: The change from colostrum to milk takes place within few days.
- Yield: For a single cow, there is a tendency for increased yields to be accompanied by a lower fat percentage and vice versa.
- Feeding: Has temporary effects.
- Season: The percentage of both fat and solids-not-fat (SNF) show slight but well defined variations during the course of year.
- Age: The fat per cent in milk declines slightly as the cow grows older.

- Condition of cow at calving: A cow would yield milk with higher fat per cent if it is healthy.
- Excitement
- Administration of drugs and hormones

There may also be variations in composition of milk obtained from a specific animal in day to day milking.

Energy values of different milk constituents

As mentioned above, the milk is a rich source of energy. The energy values of different milk constituents are as follows.

- Milk fat : 9.3 Cal/g, •
- Milk protein : 4.1 Cal/g, •
- Milk sugar : 4.1 Cal/g

Thus, with the available constituents, 100 g of cow milk usually gives 75 Cal and that of buffalo milk gives 100 Cal.

What is colostrum

During approximately the first three days of lactation, the buffalo/ cow secretes colostrum. This is very vital for the newborn calf and its composition reflects the calf's need. Colostrum contains the important proteins; the immuno-globulins, which are the newborn calf's source of antibodies. The content of iron and copper is markedly higher in the colostrum as compared to normal milk.

The average composition of colostrum is as follows.

Water: 73%	Fat: 9.55%
Total Protein: 9.59%	Lactose: 7.54%
Vitamin A: 1.8µg/kg	

Changes of milk due to boiling

When the milk is boiled there are several changes in it due to the presence of different constituents. These changes are mainly in the following form.

- Decrease in the percentage of cream
- Decrease in curd tension
- Decomposition of proteins
- Destruction of enzymes
- Darkening of the color of milk
- Coagulation of albumin and formation of a scum on the surface
- Acquiring a cooked taste
- Precipitation of Ca and Mg salts

- Breaking up of fat globules
- There may be stone formation in milk during heating.

Stone formation in milk

If the milk being processed has had no previous heat treatment, there are two types of deposits on the heat exchanger/ container surface. This is known as stone formation in milk or fouling.

1. Fouling at low temperatures

- The soft, voluminous, curd-like material, which starts to form when the temperature exceeds about 75°C.
- It is at its maximum in the temperature range 95-110°C, and then reduces in amount at higher temperature.
- This type of deposit restricts the flow passages area and causes increase in the operating pressure.
- It has high protein content (50-70%), and a lower mineral content (30-40%).

2. Fouling at high temperatures

- Deposits formed at higher temperatures
- Increases in quantity up to the highest temperature reached in the heat exchanger.
- Hard and granular in structure containing mineral (70-80%) and protein (10-20%).
- This deposit interferes more with heat transfer than with flow, and hence to reach the required processing temperature, the temperature of the heating medium has to be increased to an undesirable extent.

Both types (1 & 2) of deposit contain negligible amount of fat (about 5%), and protein and minerals are the main constituents. The amount of fouling depends greatly on the pH of raw milk. As the pH falls below about 6.5, a large amount of deposit is formed. Milk with high contents of β -casein are more prone to deposit formation. but the addition of pyrophosphates to milk brings about a significant improvement.

IMPORTANT PROPERTIES OF MILK

The knowledge of different properties of milk and milk products are required to design the processing and storage structures for milk. The important properties are discussed below.

Density and specific gravity

The knowledge of density is important to

- monitor changes during processing
- check adulteration
- separate the different constituents of milk (by methods such as centrifugation, cyclone separation, etc.)

- transport liquid milk as well as processed milk products (by different methods as pneumatic/ hydraulic transportation, etc.)
- design and develop storage structures for milk and milk products

The density and specific gravity of milk is usually given at 15.6°C (60° F). (The specific gravity of water is usually expressed at 4°C). The specific gravity of some major milk constituents are: water: 1.00; fat: 0.93, protein: 1.346, lactose: 1.666, salts: 4.23, and SNF: 1.616. As we have already discussed that the milks obtained from different animals vary in composition, the densities will also vary.)

The density of milk of different animals are given below.

- Cow milk : 1.028-1.03
- Buffalo milk : 1.03-1.032
- Skim milk : 1.035-1.037
- Milk powder (bulk density) : 0.83 (Milk powder has a porosity of 43-51%)

Though the buffalo milk contains higher fat, still due to higher SNF, the specific gravity is more than cow milk.

Determination of specific gravity of milk by Lactometer



Fig. 2.2 A lactometer immersed in a cylinder

- A lactometer (or galactometer) is a hydrometer used to test milk.
- The specific gravity of milk does not give a conclusive indication of its composition since milk contains a variety of substances that are either heavier or lighter than water. Additional tests for fat content are necessary to determine overall composition.

- The specific gravity of milk should not be determined for at least one hour after it is drawn from the animal, or else, a lower than normal value will be obtained.
- Quevenne is an arbitrary scale used with hydrometers or lactometers in the determination of the specific gravity of milk. degrees Quevenne = 1000 (specific gravity - 1).
- The specific gravity of milk is calculated by dividing the Quevenne's degree by 1,000 and adding 1. i.e. if the Quevenne reading is 31, then

$$\text{specific gravity} = (31/1000)+1= 1.0031$$

Correction for temperature

The lactometers are normally standardized at a particular temperature (say (60°F or 15.6° C). If the temperature is above or below the standard temperature of 60°F, the lactometer reading should be corrected by adding 0.1 to the lactometer reading or 0.0001 to the specific gravity for each °F above 60°F and vice versa for lower temperatures.

Example: If the meter reading becomes 31.0 at 66°F, what is the specific gravity of milk?

Solution:

The corrected lactometer reading is $31.0+0.6=$ or 31.6

Specific gravity: $1+31.6/1000 = 1.0316$

In another method, the instrument is graduated into a hundred parts. Milk is poured in and allowed to stand until cream has formed. The depth of the cream deposit in degrees determines the quality of the milk.

Another instrument, invented by Doeffel, is two inches long, divided into 40 parts, beginning at the point to which it sinks when placed in water.

Some other types of hydrometers

- Alcoholometer: to measure alcoholic strength of liquids
- Saccharometer: to measure amount of sugar in a solution
- Thermohydrometer: that has a thermometer enclosed in the float section
- Barkometer: to measure strength of tanning liquors used in tanning leather
- Battery hydrometer: charge of a lead-acid battery can be estimated from the density of the sulfuric acid solution used as electrolyte.
- Antifreeze tester: to test the quality of the antifreeze solution used for engine cooling.

Total solids and total SNF

The total solids and solids not fat (SNF) are determined as follows (The method is known as Gerber method).

$$\text{Percentage total solids} = 0.25 D + 1.22 F + 0.72$$

$$\text{Percentage SNF} = 0.25 D + 0.22 F + 0.72,$$

In the above equations, $D=1000(d-1)$, where $d=$ specific gravity of sample of milk at 20°C, and F is the fat percentage in sample.

Case I: What is the amount of total solids and SNF with a milk having 3% fat and density of milk is 1016 kg/m³ (@20°C).

Solution:

$$D = 1000(1.016-1.00) = 16$$

$$\text{Per cent total solids} = 0.25(16) + 1.22(3) + 0.72 = 8.38$$

$$\text{Per cent SNF} = 0.25(16) + 0.22(3) + 0.72 = 5.38$$

Freezing point

Due to the dissolved solids in liquid milk and milk products, the freezing points are normally lower than the freezing point of pure water. In fact, more the concentration of solids, more will be the freezing point depression. The freezing points of different types of milk are as given in Table 2.2.

Table 2.2. Freezing points of different types of milk

Type of milk	Freezing point
Fresh whole milk	-0.506°C to -0.504°C
Indian cow milk	-0.547°C
Buffalo milk	-0.549°C
Evaporated milk	-1.4°C
Sweetened milk	-15.12°C to -12.04°C

Souring results lowering in freezing point due to increase in the amount of soluble molecules. Hence unsoured samples should be tested for determination of freezing point. Another important point is that the volume of milk is always increased when it is frozen.

The knowledge of freezing point of milk is important as it is employed for detection of adulteration.

Boiling point

As mentioned above, the boiling point of milk is also little higher than that of pure water due to the dissolved solids.

For normal milk at atmospheric pressure, the boiling point is around 100.5°C (100.2-101°C). As a thumb rule, when the concentration is doubled, the boiling point rises by about 0.5°C, and if the concentration is 3:1, the boiling point rise is 0.8°C.

The addition of solids, salts, sugars, acids, etc. raises the boiling point. The boiling point also varies with composition and pressure.

Specific heat

The specific heat of milk varies depending upon the fat content and temperature. The general values are as follows.

Whole milk : 3.89-3.93 kJ/ kg-°K (0.93-0.94 kCal/kg-°K);
 Skim milk : 3.97 kJ/kg-°K (0.95 kCal/kg°K)

Thermal conductivity

The thermal conductivity of milk is found out by Lamb's equation, which is as follows:

$$K=0.0801 + 0.568 M_w$$

Here M_w is the moisture fraction (i.e. expressed in decimals)

Acidity and pH

The milk is acidic and the average natural acidity is as follows.

Cow milk : 0.13 to 0.14% (natural acidity)

Buffalo milk : 0.14 to 0.15%

The developed or real acidity is due to lactic acid formed as a result of bacterial action on lactose on milk. The titrable acidity is the sum of developed and natural acidity.

The pH is another measure of acidity and the pH values of milk are as follows.

Normal fresh sweet cow milk : 6.4-6.6

Buffalo milk : 6.7-6.8

Higher pH value of milk indicates udder infection and the lower value indicates bacterial action.

The acidity and pH of fresh milk varies with species, breed, individuality and stage of lactation and as well on health of animal.

Viscosity

The materials of high viscosity would require a large surface, slow moving type agitator to move them properly. Besides, viscous materials cause a slow moving film on heating and cooling surfaces, and thereby reduce the rate of heat transfer. The pump pressure for forcing the liquid through pipe lines will also increase. Table 2.3 gives the average values of viscosity of milk at different temperatures.

Table 2.3 Viscosity of milk forms (Viscosity in Pa.s)

Type of Milk	Temperature, °C			
	10	20	40	80
Whole milk	2.79	2.12	1.24	0.68
Skim milk	2.44	1.74	1.03	0.53
Whey	1.71	1.26	0.82	0.68

The above table is a representative one and there can be variations. The viscosity of milk also varies according to composition, age and treatment.

The viscosity of milk can increase during processing and storage. In particular, the increase of viscosity is observed during

- Increase in concentration
- Homogenization
- Ageing at low temperature.

The milk and milk forms can be categorized as Newtonian and Non-Newtonian fluids as follows.

Newtonian fluids: milk, skim milk, cheese, whey permeate, etc.

Non-Newtonian fluids: suspensions, pastes, emulsion, etc.

Surface tension

Surface tension is the force per unit length acting on a length of surface of a body or the work done in increasing its surface area under isothermal conditions. The surface tension forces are responsible for the finely dispersed liquids to form spherical droplets (minimum surface area to volume ratio).

Table 2.4 Surface tension of some commodities

Material	Surface tension, mN/m
Water	72.6
Cow milk	52
Buffalo milk	50.5
Whey	0.68

Color of milk

- The color of milk is a blend of individual effects produced by: (1) colloidal casein particles and dispersed fat globules, both of which scatter light, and (2) carotene (to some extent xanthophylls), which imparts a yellowish tint.
- Thus, the color of milk ranges from yellowish creamy white (cow milk) to creamy white (buffalo milk).
- The intensity of the yellow color of the cow milk depends on the factors such as breed, feed, size of fat globules, fat per cent in the milk, etc.
- Greater intake of green feed results in deeper yellow color of milk.
- Larger the fat globules and higher fat percentage will impart a greater intensity of yellow color.
- Skim milk has a bluish and whey a greenish yellow color.

Refractive index

- The average refractive index of cow milk and buffalo milk at 40°C are as follows.
 - cow milk : 1.3461
 - buffalo Milk : 1.3477
- Total refraction is sum of individual refractions of the constituents present in the solution.
- The measure of refractive index can be used to determine adulteration, especially watering. However, the freezing point is more reliable than refractive index for determination of adulteration.

Flavor

- It is composed of smell (odor) and taste.
- The flavor of milk is a blend of sweet taste of lactose and salty taste of minerals, both of which are damped down by proteins.
- The phospholipids, fatty acids and fat of milk also contribute to the flavor.

Usually the changes in flavor/ abnormal flavor in milk occur due to:

- Type of feed
- Chemical composition as well as chemical changes
- Season
- Stage of lactation
- Condition of udder
- Sanitation and other conditions during milking and subsequent handling of milk, during storage
- Bacterial growth
- Addition of foreign material
- Absorbed materials

Agitation

The agitation of dairy products containing butter fat should be gentle but complete and uniform. Severe agitation causes clumping and churning of butter fat and disturbances in cream formation. Insufficient agitation will cause localized overheating and burning of products. Pressure intensifies the churning effect of agitation.

Expansion of milk

Milk product which have entrapped air in them greatly increase in volume as the temperature rises. The expansion of milk is of practical significance because of its bearing on the capacity of tanks.

Overrun

When air is incorporated into a whipped or frozen product, the density decreases. The amount of entrapped air incorporated is measured as overrun.

Overrun of 2-3 times the total solid contents are recommended. Too low overrun yields a heavy product. Too high overrun gives too light and fluffy product.

Foaming of milk

Pure liquids do not foam and the foaming of solution is correlated with the surface activity of the solutes. The following table shows the different types of materials/ constituents forming the foam.

Less Foam	Transient Foam	Persistent foams
Mixtures of liquids of similar chemical type and surface tension Aqueous solutions of highly hydrophilic solutes, e.g. sucrose.	Solutes, which lower the surface tension moderately	Solutes, which lower the surface tension strongly in dilute solution, e.g. proteins.

Lecture 4

PROCESS FLOW CHARTS

FLOW CHART

A flow chart is a representation of sequence of operations in a processing plant or in a process. For example, if we want to prepare dried vegetables, the sequence of operations will be sorting, washing, peeling, slicing and then drying either under sun or in a mechanical dryer. But we may also think of blanching of the vegetable or treat with sulphur dioxide depending on the characteristics of the commodity and product. Thus if we prepare a flow chart of these processes, the flow chart may look somewhat like as in Fig. 3.1.

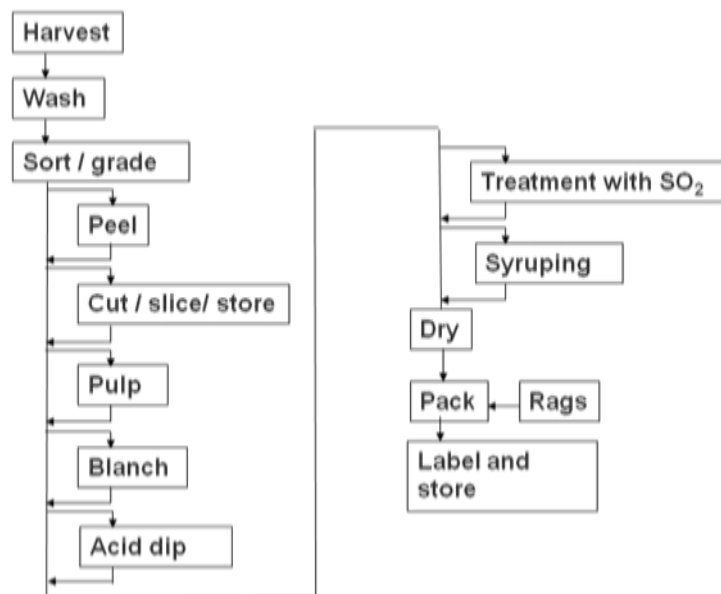

Fig. 3.1 Flow chart for vegetable dehydration

For preparation of a flow chart, first of all we have to know the sequence of operations. Or in other words, we can know the proper sequence of operations and better understand the process, if we have a flow chart of the process. We can also know the critical control points and we also know where to improve.

The flow chart also helps in identifying each unit operation in the process which helps in proper selection of equipment and better management of man and machines. For example, the type of equipment that will be required for the preparation of dehydrated vegetables will be as follows.

Equipment required for vegetable dehydration

- Wash tanks or special washers
- Knives, peelers, small peeling machines
- Fruit and vegetable choppers, cutters, slicing and dicing machines
- Pulpers, liquidizers, steamers, or at a large scale, pulper-finishers
- Boiling pan, heat source, wire basket or steamer
- Weighing scales or scoops, sulfuring cabinet or food grade plastic tank
- Weighing scales or scoops, boiling pan, heater, food-grade tank, muslin cloth filter
- Sun-drying, solar dryer, any type of suitable dryer
- Electric heat sealer for plastic bags

So now we have understood that the flow charts are very important for understanding and monitoring a process. In this section, we will discuss how the flow charts are prepared for some common milk processing operations. In fact this will also help you in understanding the methods of preparation of these specific products.

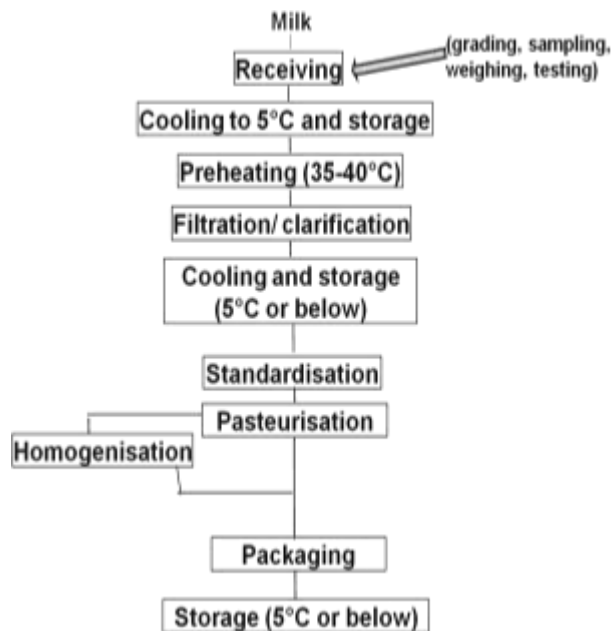

Fig. 3.2 Flow chart for preparation of pasteurized milk

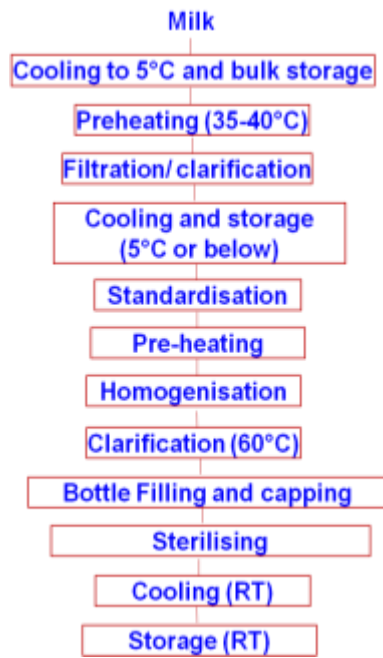

Fig. 3.3 Flow chart for preparation of sterilised milk (In-bottle sterilization)

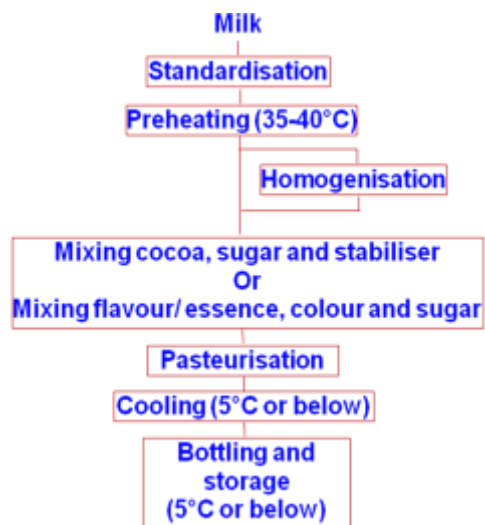

Fig. 3.4 Flow chart for preparation of flavoured milk

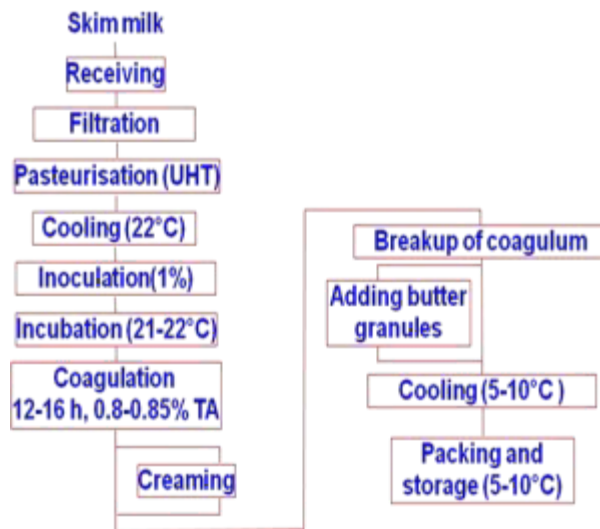

Fig. 3.5 Flow chart for preparation of butter milk

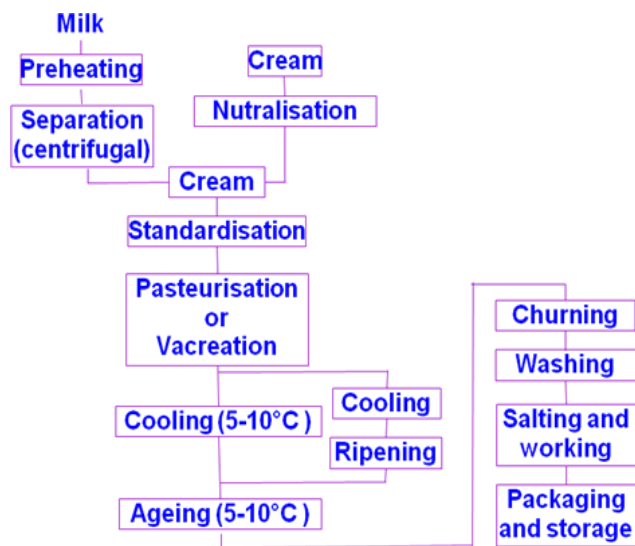

Fig. 3.6 Flow chart for preparation of butter



Fig. 3.7 Flow chart for preparation of ice cream

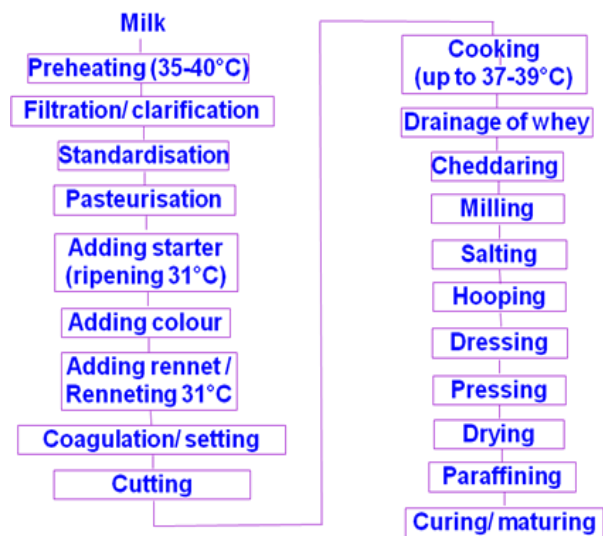

Fig. 3.8 Flow chart for preparation of cheddar cheese



Fig. 3.9 Flow chart for preparation of cottage cheese

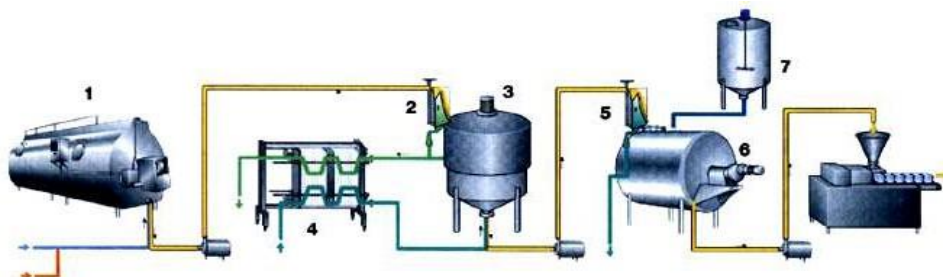

Fig. 3.10 Equipment flow chart for preparation of cottage cheese

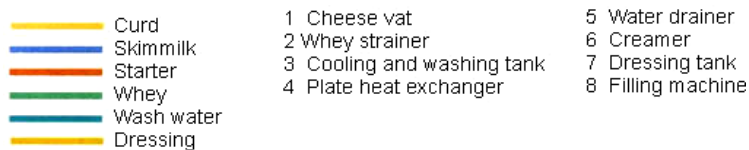

Fig. 3.11 Flow chart for preparation of evaporated milk

Lecture 5

RECEPTION OF MILK

MILK RECEPTION IN THE CANS

Milk is received in the processing plant from the primary producers or the milk collection centers. Usually they are transported by cans or bulk containers (milk transport tanks or vans).



Fig. 4.1 Milk can (usual capacity 20-40 litres)

- The first stage of reception involves emptying of cans over the tip tank or weigh tank. Emptying cans over the tip-tank can be done either by hand, or by hand assisted method or by mechanical methods (inverter). The process of inversion may be a serious source of contamination of the tipped milk by soil from can exteriors.
- In some canneries, the can is not completely inverted (the base of can is never directly above the surface of milk).
- After weighing and recording of consignment, the contents are discharged into a tank immediately below the tip-tank, from which the milk is pumped through a cooler to a storage tank.
- Where milk is measured volumetrically, the cans are tipped directly to the tip tank from which milk is pumped to the cooler.



Fig. 4.2 Weigh tank

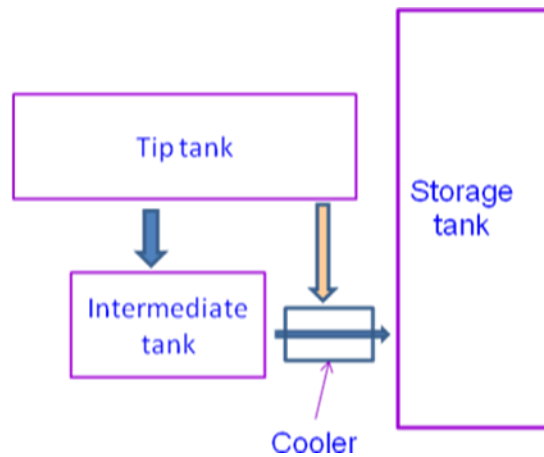

Fig. 4.3 Arrangement of tanks in milk reception section plants.



Fig. 4.4 Bulk milk Coolers

The following approach is done for the mechanization of milk reception sections of dairy

- Power driven or gravity roller conveyors are used for conveying of the milk cans.
- Tipping may be manual or completely automatic.
- The inverted can is moved in that position to the drainage rack and into can washer.

RECEIVING SECTION FOR BULK MILK

The receiving section for the bulk milk may be divided into three subsections as follows.

Preparing to unload Unload

Weigh

The different activities carried out in these subsections are shown in Fig. 4.5.

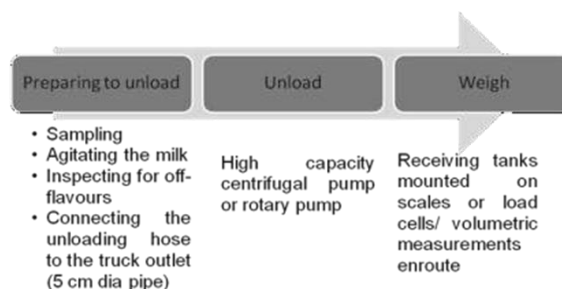

Fig. 4.5 Activities during the receiving of milk

Modern dairy plants use air operated valves to control flow in the receiving operation and CIP systems for tankers, tanks and pipelines. Unloading is done by large stationary pump. Plastic hoses are used for the purpose.



Fig. 4.5 Milk reception for bulk milk containers Methods for measuring bulk milk

- Weighing or measuring tankers
- Weighing in receiving or storage tanks (with load cells)
- Metering
- Liquid level measurement in storage tank
- Weighing of trucks on scales before and after emptying
- Sanitary meters are used in a number of plants, in which the measurement is by determining volumetric displacement, mass flow rate or velocity.

MILK TRANSPORT TANKERS

- Usually the milk tankers have capacities of more than 12000 ltr (7500-25000 ltr)
- The basic features of milk transport tanks are:
 - Inner shell of stainless steel (18% Cr and 8% Ni)
 - Intermediate thick insulation layer (cork, plastic foam, mineral wool, etc.)
 - Outer jacket (ordinary carbon steel, Al, s.s.)
 - Necessary fittings
- Stainless steel is preferred for long life, low maintenance cost, and excellent appearance, but they are costlier.
- If the milk tank incorporates a pump, hose, flow meter, or other utensils necessary for collection of milk, then it is called bulk milk pick-up tank.

There are three important considerations during unloading from milk transport tanks

- Safety
- Temperature
- Agitation

The agitation of milk is very important and is required when the milk is to be delivered to two or more storage tanks. Further, when the milk is stored for some time, the fat will have a tendency to settle and there will be non-uniform distribution of milk fat in the milk.

In that case agitation is required for uniform butter-fat distribution. For the purpose, built in electrically driven horizontal agitators are provided in the milk tanks.

STORAGE TANKS

In a dairy plant, storage tanks are used for raw products, pasteurized products and for processed products as well.



Fig. 4.6 Different applications of storage tanks Storage tanks for raw milk

Usually milk is held up to a maximum of 72 hours between reception and processing in the tank. The tanks may be cylindrical or oval. They may also be horizontal/ vertical.

The storage tanks are often kept outdoors with heads extended through the wall into processing room.

Main considerations

The temperature and sanitation are the two main considerations in a milk storage tank.

Temperature. Milk temperature is maintained at less than 7°C.

Sanitation

- Tanks must be designed for sanitizing, preferably for CIP.
- Surfaces must be smooth, polished and welds in particular have to be made flush, polished and pickled.
- All closed type tanks must be equipped with a manhole, either round (dia about 450 mm) or oval in shape, to permit access to the interior for cleaning and inspection. They are fitted with a swing cover.
- Head space of approximately 15 cm.

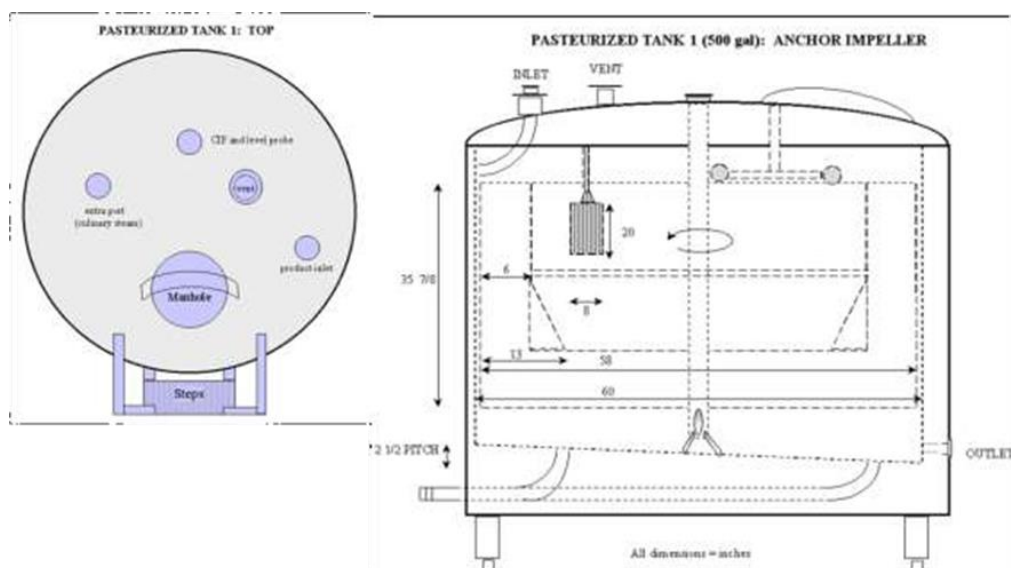

Fig. 4.7 Different parts and accessories of milk storage tanks Storage tank- accessories

- A curved filling pipe which guides the milk towards the wall (for foam free entry of milk). It is always better to fill the tank from below.
- Viewing ports and lights, spray heads and rotating heads (for cleaning) in the head space.
- Air vent (with screen) of sufficient size to prevent excessive pressure during filling and vacuum during emptying.
- Thermometer probes
- Liquid level gauges (may be a sanitary float with external indicator)
- Agitators (for assuring uniform composition to aid in standardizing, and to improve cooling efficiency in refrigerated storage tanks- may be vertical/ horizontal).

Milk silo

The milk silos are usually of the capacities of 50,000-100000 tonnes. The silos are useful in that they can hold large amount of product in less area. Other considerations are

- Bottom slope 6%.
- Control panel to show temperature, pressure, etc.
- Electrode at the drainage line to indicate when tank becomes empty.\



Fig. 4.8 Milk Silos

The milk silos should be provided with some device for agitation to avoid cream formation. The following points should be considered while providing the agitators in the tank.

- Agitation should be smooth. Vigorous agitation causes aeration of milk and fat globule disintegration. Aeration also exposes the fat to lipase in the milk.
- Propeller agitator is preferred.
- For very tall tanks, two agitators may be provided at different levels.

Refrigerated storage tank

- Must cool the milk to a required temperature in a specified time.
- Must maintain the milk below a specified temperature.
- Must maintain the milk below a designated maximum when milk is added.
- In most cases, there is a jacket around the tank for circulation of chilled water or refrigerant.

Process tanks

- Used for treatment of product.
- Examples are ripening tanks for butter cream and for cultured products such as yoghurt, and crystallization tanks for whipping cream, and tanks for preparing starter culture.

Aseptic tank

- Used to store UHT processed milk if it is necessary to have an intermediate tank between sterilizing plant and packaging machine.
 - When part of a plant is out of operation (for instance when it has to be cleaned or because there has been a breakdown), a total shut down is not necessary.
- Should have strong and thick walls (as it has to be sterilised together with product pipes by dry steam at pressure of 3 to 5 kg/cm², before it can be used).
- There should be cooling jacket for cooling the milk immediately after steam sterilization.
- Before the UHT milk enters the tank, it must be ventilated with sterile air to drain away any condensate which may have formed.

Lecture 6

PASTEURIZATION OF MILK

(Objectives of pasteurization, Pasteurization requirements for milk, Methods and equipment for long hold batch type pasteurization, HTST pasteurization, UHT pasteurization)

Pasteurization is the process of heating the product to a predetermined temperature and holding it until all or nearly all objectionable microorganisms, which may be present, are killed. (This was developed by Louis Pasteur, 1960)

Objectives of pasteurization

- To make the product safe for human consumption by destroying the pathogenic organism, which may be present.
- Improves preservation quality by destroying almost all spoilage organisms.
- Helps to retain good flavor over a longer period of time.

Pasteurization requirements for milk

Pasteurization by heating and time treatments are a compromise among bacterial killing along with a number of other factors such as taste, phosphate inactivation, cream line reduction, etc. The target microorganism for milk processing is *Micobacterium tuberculosis* (TB germ). The following Table 5.1 shows how the pasteurization process has been standardized considering these factors. Accordingly, the methods of pasteurization can be given as in Table.

Table. Standardization of pasteurization requirements for milk

Requirement	30 min	15 sec
Kill TB germ	138°F	158°F
Phosphate inactivation	142°F	160°F
Pasteurization requirement	145°F (63°C)	161°F (72°C)
Creamline reduction	146°F	162°F

Table . Methods of pasteurization for milk

Methods	Treatment
Long hold batch type / Vat pasteurization	63°C-30 min
High temperature short time (HTST) pasteurization	72°C-15 s
Ultra high temperature (UHT) pasteurization	88°C-3 s

However, the time and temperature combination maintained in a dairy plant may vary from the above Table values depending on the initial microbial load and other considerations.

LONG HOLD OR VAT PASTEURIZATION

The long hold or vat pasteurization is a batch type method where the pasteurization is carried out at 63°C for 30 min. The basic operations involved in a vat pasteurizer are given in Fig.

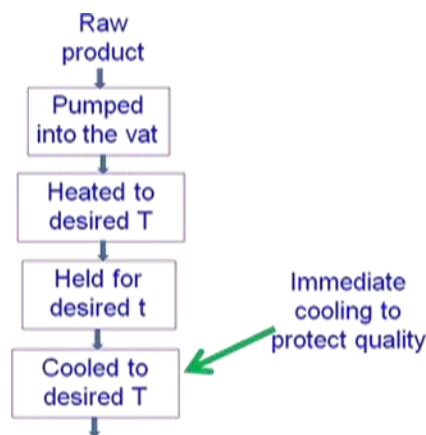

Fig. Basic operations in a vat pasteuriser Types of vat pasteurizers (Classification based on flow of heating medium)

- 1.Spray type
- 2.Flooded type
- 3.High velocity flooded type

General requirements

The following are the requirements for a successful batch pasteurization process.

- Rapid heating: Generally the circulation of heating medium is started as soon as filling of the vat is begun, thus shortening the heating time.
- Immediate cooling: In some designs the cold water is circulated over the outside of the inner lines as soon as the holding period is completed, so a part of cooling can be done in the vat itself.
- Heating medium should be only a few degrees warmer than milk to prevent formation of milk stones on heating surfaces and cause minimum injury to cream line or flavour.
- Agitation. Agitation of milk within a certain degree helps in improving the heat transfer.
- Agitation is easier in case of hot fluid than cold ones.

- Agitation should not develop foam and it should not injure the cream line.
- Viscosity of the fluid greatly affects the type of agitator. Less viscous materials require small diameter high speed agitator. Highly viscous materials require slow speed large surface blade type agitators.

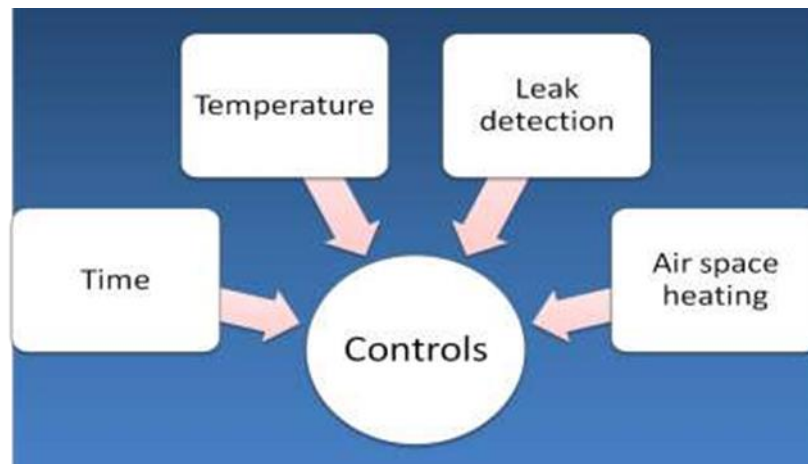

Fig. Pasteurizer Controls

For vat pasteurizers, an electric or air operated control can be connected with a timing clock so that the heat is shut off when the proper milk temperature has been reached and a bell rings when the proper length of holding time has elapsed. Also temperature of heating water can be controlled during the holding period.

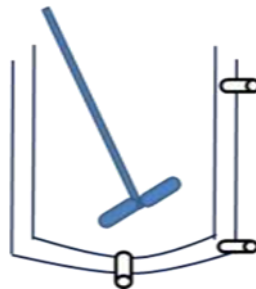

Fig. Schematic representation of a long hold batch type pasteurizer

Advantages

- Well suited for small plants, low volume products
- Variety of products can be handled.
- Well suited for cultured products such as bottle milk, sour cream, etc.
- Simple controls
- Low installation cost

Disadvantages

- Batch type
- Slow process
- As the controls are mostly manual, it requires constant attention.

•Both heating and cooling are relatively expensive (as we do not have heat regeneration).

HTST PASTEURIZATION

High temperature short time pasteurisers are usually continuous flow systems using heat exchangers. Generally plate type heat exchangers with regenerative heating, heating and cooling systems are used.

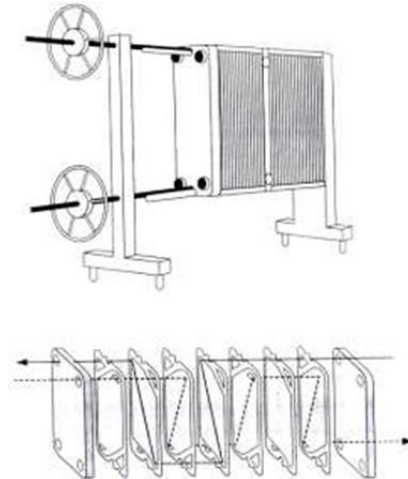

Fig. 5.4 Plate heat exchanger

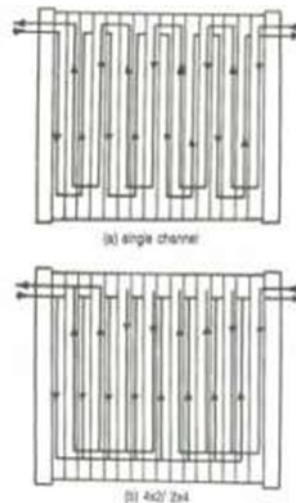

Fig. 5.5 Flow pattern in plate heat exchangers



Fig. 5.6 Types of plates used in plate type heat exchanger

Basic components of HTST pasteurization system

The HTST pasteurization process and its basic components are shown in Fig. 5.7. First from a constant level tank, milk is pumped by a booster pump into a heat exchanger to heat it with the help of pasteurized milk to about 60°C. As the pasteurized milk is used for heating the raw milk and there is no external heating source, we call that a regenerative heater. The regenerator reduces the actual heat requirement for pasteurization and hence is very important for the overall cost effectiveness of the system. Then the milk enters into the heater where the temperature of milk is raised to the actual pasteurization temperature. The milk then passes through the holder, where the milk temperature is maintained for the specific time so that pasteurization is completed. Then the pasteurized milk goes to the regenerator so that it gives away some heat to the raw milk. It is also simultaneously cooled so that the refrigeration requirement is reduced. After the regenerator, the pasteurized milk goes to a chiller, where the milk temperature is reduced to about 4-5°C.

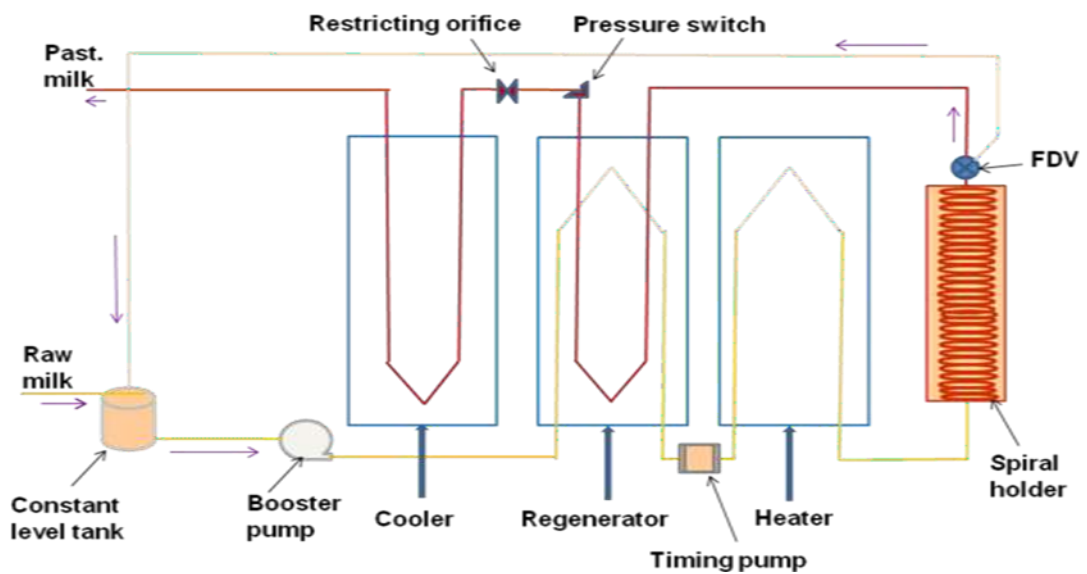

Fig. 5.7 HTST pasteurization process



Fig. 5.8 A HTST pasteurizer

For HTST pasteurization, the following controls are very important.

- Flow rate
- Temperature
- Pressure

Control for flow rate

- The flow rate is regulated by a metering or timing pump
- A positive displacement pump of rotary or piston type is used.
- Often variable speed drives are used to change the rate of flow when desired.
- Pump must be sized and perfectly driven such that flow rate does not exceed the actual, i.e. the holding time is not below legal minimum.

Control for temperature

- Control of temperature includes means for maintaining a uniform product temperature at or above the legal minimum at a safe value.
- It should divert the flow back to the system if the temperature at the end of holder is below legal minimum.
- Usually a safety thermal limit recording controller is used. (It makes a continuous record of the temperature and marks the time when the flow diversion valve operates.)

Control for pressure

The pressure control is important in the following three sections.

- In the regenerators
- In the flow diversion valve
- In the diverted milk lines (for homogenization, etc.)

Pressure related problem in the regenerator

The different causes and effects of pressure related issues in a pasteurization system are given in Fig. 5.9. As it can be seen, the centrifugal booster pump takes care of the pressure related problems in the regenerator. Besides, there are three more devices as the timing pump, pressure switch and the restrictor, the functions of which are given below.

- Timing pump: It assures that the pasteurized product side is always under higher pressure than the raw side in the regenerator.
- Pressure switch: It will allow the pump to run only when the pressure in pasteurized side is at least 1 psi more than the raw side.
- Restrictor: It is an additional device to satisfy the minimum 1 psi difference if the cooler section does not produce enough back pressure on the pasteurized side.

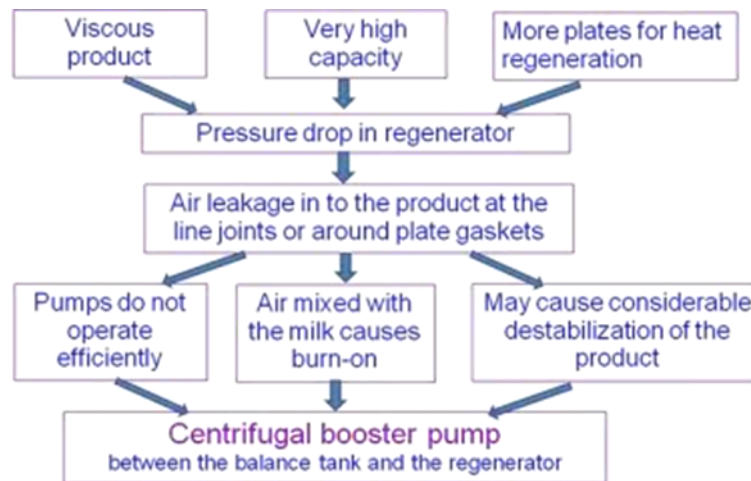

Fig. 5.9 Use of booster pump in a pasteurization system Pressure management in the flow diversion valve

- The thermal limit recorder not only makes a record of the temperature of the milk, but also indicates, records and controls the action of the flow diversion valve.

Pressure management in diverted milk line

- The other pressure management is needed on the diverted milk line, since it may affect the holding time during diversion.
- If the holding time during diverted flow is shorter than that in forward flow, a restricting orifice should be placed in the divert line.

Main parts of HTST pasteurizer

Now that we have discussed the process and the controls required during the process, we can write down the main parts of HTST pasteurizer as follows.

- Constant level tank
- Regenerator
- Booster pump
- Timing pump
- Heater
- Holder
- Flow diversion valve
- Pressure switch
- Restricting orifice
- Cooler

Important accessories

- Leak detector valves at all inlet and outlet pipes.
- Air space heaters (Air space heating is done by introducing steam above the level of the product).

Advantages of HTST pasteurization

- Uniform treatment.
- Temperature is regulated at close limits and overheating is prevented.
- Economical than batch systems (due to regenerative heating).

Disadvantages

- The system is complicated.
- Not portable.
- Installation cost is more.

ULTRA HIGH TEMPERATURE (UHT) PASTEURIZATION

As we have discussed previously, the UHT pasteurization process involves heating the milk at a temperature of 88°C for 3 sec. The equipment is much the same as the HTST units and the controls are also similar, but the operating temperature is higher. The holder is much smaller for smaller pasteurizing time.

Advantages

- Better texture of milk due to short holding time
- Greater bacterial destruction is possible.

When UHT treatment is needed for greater bacterial destruction or its beneficial effect on the body and texture of ice cream, then the treatment may be given following regular pasteurization.

Pasteurization and homogenization

- Since nearly all fluid milk and ice cream mix etc. are homogenized, homogenizers are integrated to the continuous pasteurization process.
- As the homogenization temperature must be at least 60°C, the homogenizer must be located either between the regenerator and heater or after the heater.
 - The equipment, when installed, should not reduce the holding time below the legal minimum either when they are operating or when they are at rest.
 - The capacity of the homogenizer can seldom be synchronized exactly with the timing pump unless a vented cover or other relief valve is employed, and then the pump operates at slightly greater capacity than the homogenizer.
 - The usual practice now a day is to use homogenizer having 3-8% greater capacity than the maximum flow rate of the system. They are equipped with a recirculation, by-pass loop from the discharge line to the suction feed line.
- Here the timing pump regulates the flow rate of the system at all the times.

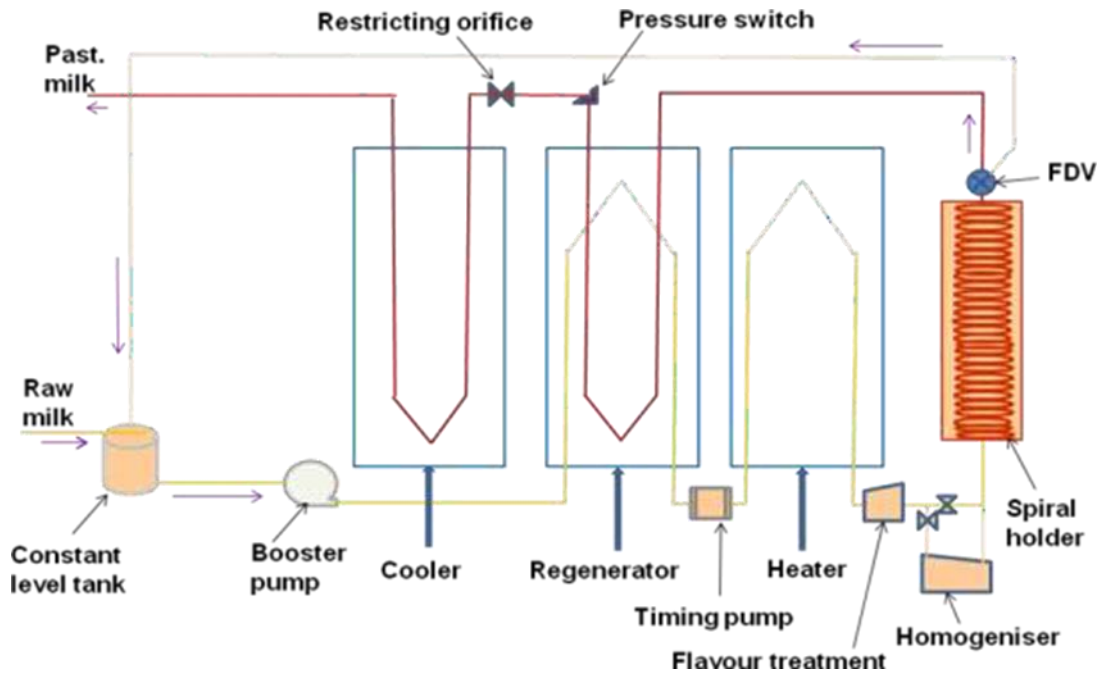

Fig. Homogenizer incorporated in HTST pasteurization system

Like homogenizers, clarifiers and separators may also be integrated into the lines of HTST and UHT systems.

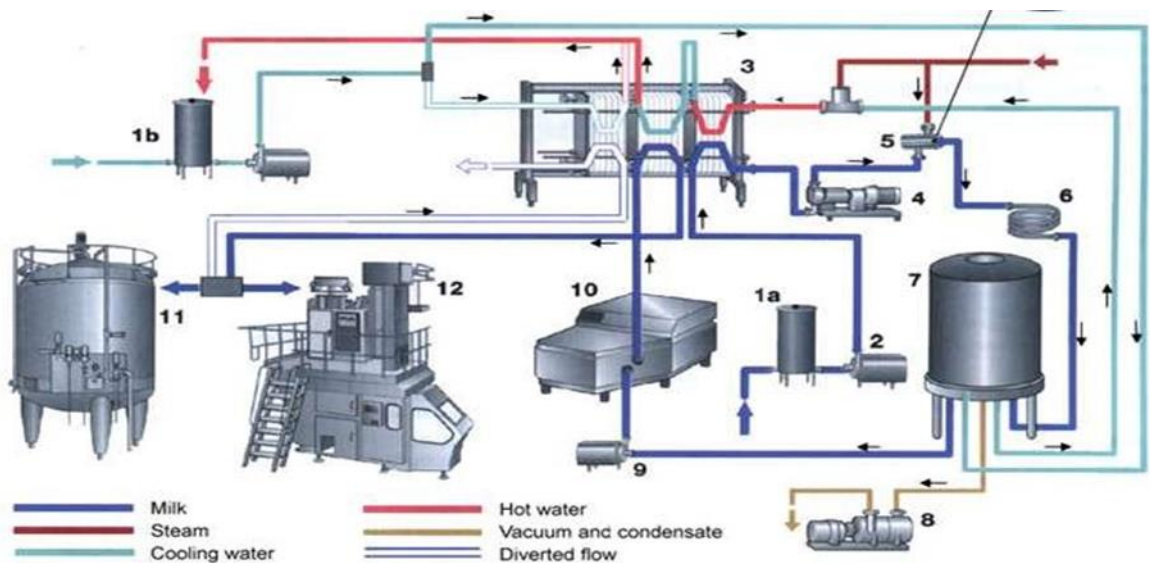

Fig. UHT process with heating by direct steam injection combined with plate HE

(1a: Balance tank milk, 1b: Balance tank water, 2: Feed pump, 3: Plate heat exchanger, 4: Positive pump, 5: Steam injection head, 6: Holding tube, 7: Expansion chamber, 8: Vacuum pump, 9: Centrifugal pump, 10: Aseptic homogenizer, 11: Aseptic tank, 12: Aseptic filling)

Uperization (Ultra-pasteurization)

This is another method of pasteurization and the unit operations involved in the process are given in Fig.

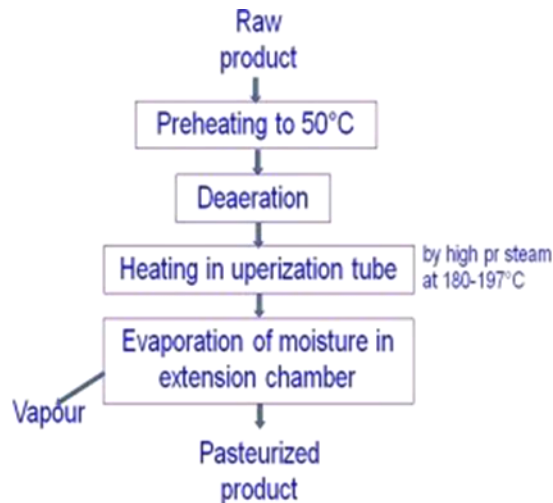

Fig. 5.12 Uperization process

The process involves heating the milk with high pressure steam at 180-197°C. The milk is heated to 150°C for less than 1 sec to obtain the desired effect of pasteurization.

Vacreation

- The process of heat treatment under vacuum in stainless steel chamber is known as vacreation.
- Vacreation is normally done for cream used in manufacture of butter. The purpose of vacreation is to
 - Kill bacteria,
 - Inactivate enzyme,
 - Remove undesirable odors and flavors,
 - Deaeration to expel dissolved air and finely dispersed bubbles.

The system consists of a product feed pump, steam pressure controller, a temperature-recorder controller, vacuum controller, milk inlet controller, concentration ratio controller. The equipment is called 'Vacreator' (trade name adopted from Protech engineering, NZ).

Care and maintenance of pasteurizing equipment

- Keep all surfaces clean
- Routine preventive maintenance and adjust controls
- Proper care and lubrication of gasket
- Lubrication of motor, pump and other necessary equipments
- Thermometers and control equipments should be checked for accuracy. Replace if out of tolerance.

Lecture 7 STERILIZATION

Objective of sterilization

The sterilization is the process of heating to a high enough temperature (usually more than 100°C) for specific time to kill almost all bacteria. The sterilized milk can be stored at room temperature for a long period of time.

The sterilization of milk has the following characteristics.

- Temperature more than 100°C is used in the process.
- No chilling is required for storage. Excellent storage life at room temperature.
- High operating pressure is employed to prevent milk from boiling at the processing temperature.

Methods of sterilization

In general there are two methods of sterilization.

Conventional method: Packaging is done before heat treatment. The processing is usually carried out at 105-110°C for 30-45 min. It is also known as In-bottle sterilization.

UHT or aseptic method: Packaging is done after heat treatment. The ultra high temperature short time (UHTST) and very high temperature short time (VHTST) processes come under this category. The processing is at 135-150°C for 1-20 seconds. Then the commodity is packed aseptically.

The difference between the conventional method and aseptic processing method can be better understood with the help of Fig.

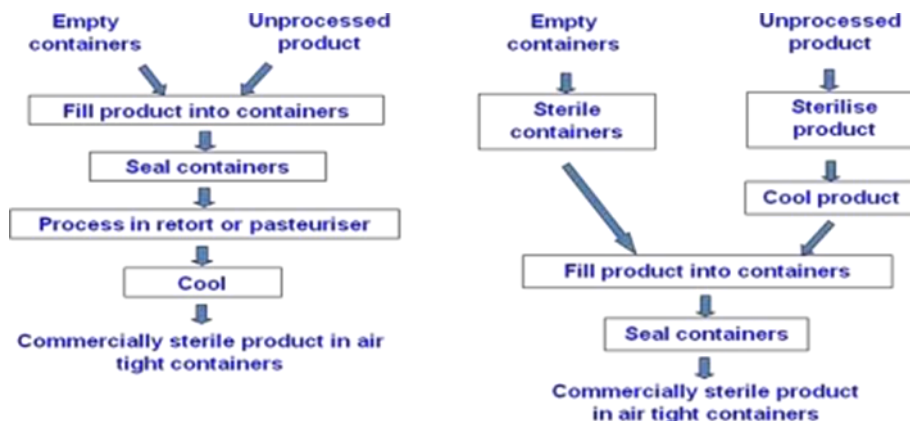

Conventional method

Aseptic method

Fig. Difference between conventional and aseptic processing methods

Conventional canning/ in-bottle sterilization:

The in-bottle sterilization method can be further categorized as batch or continuous types.

The basic flow chart to explain the in-bottle sterilization is given in Fig.

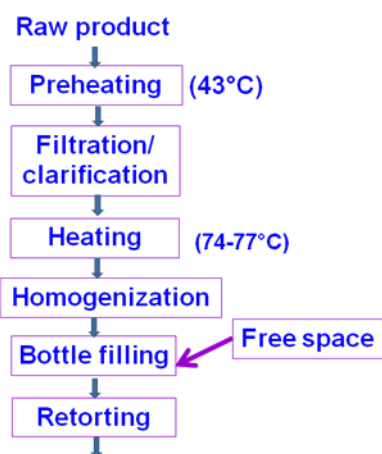

Fig. In-bottle sterilization process

Batch sterilization:

The equipment which is used for the sterilization process is called a retort and the processing is often called retorting. The batch retorts can be either horizontal type or vertical type. The retort has a lid or door with good fastening. It has necessary controls for temperature, pressure and safety devices. They can also be of circular or rectangular cross section.



Fig. A horizontal retort

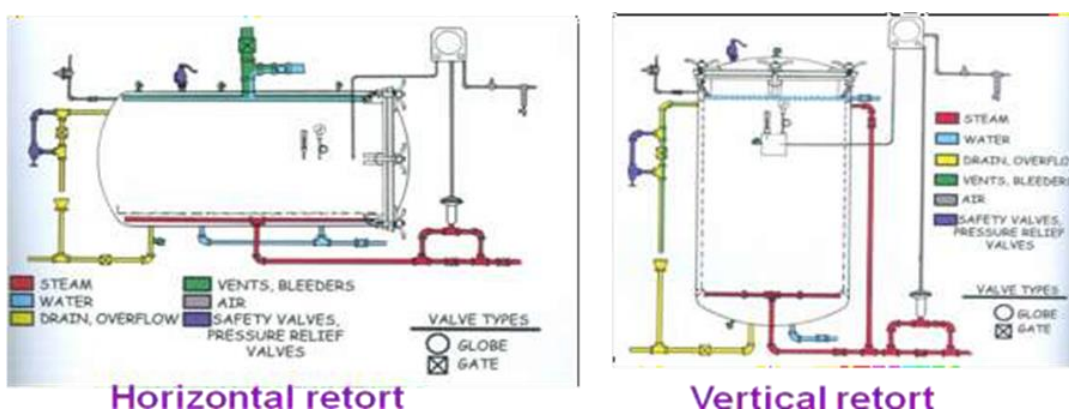

Fig. Basic parts of retort

The batch retorting process can be explained as follows.

- The bottles are loaded onto crates and then the crates are travelled into sterilizer with the help of a trolley/truck.

- After the commodity is packed, the door is closed, the vessel is supplied with steam at required pressure.
- The processing time and pressure are properly maintained by controls.
- After desired processing time, steam is vented to atmosphere.
- After this the crates (bottles/cans) are immediately cooled by air (fans) to avoid further cooking of the product.

Water spray or cascading water retort:

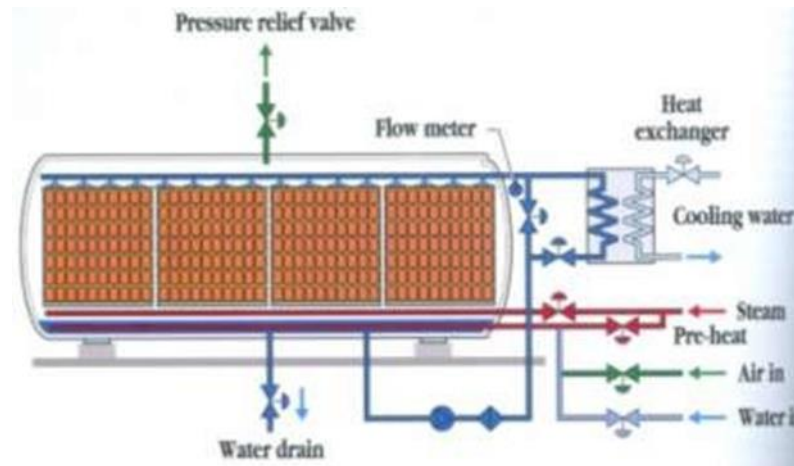

Fig. Water spray or cascading water retort

The characteristics of water spray or cascading water retort are as follows.

- It uses a low volume of water.
- Water does not completely cover the containers during processing, but instead sprays or cascades (showers) on the containers.
- The system collects (draws) water from the bottom and reintroduces through sprays from the top and mid-section of the vessel to heat or cool.
- Heating of water is done internally by steam spreaders.
- Air is the source of overpressure.

Rotary batch sterilizer:

This sterilizer agitates milk during heating by rotating the load of bottles about a horizontal axis.

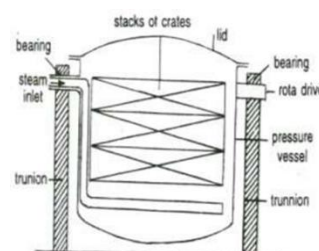

Fig. Rotary batch sterilizer

Hydrostatic retort:

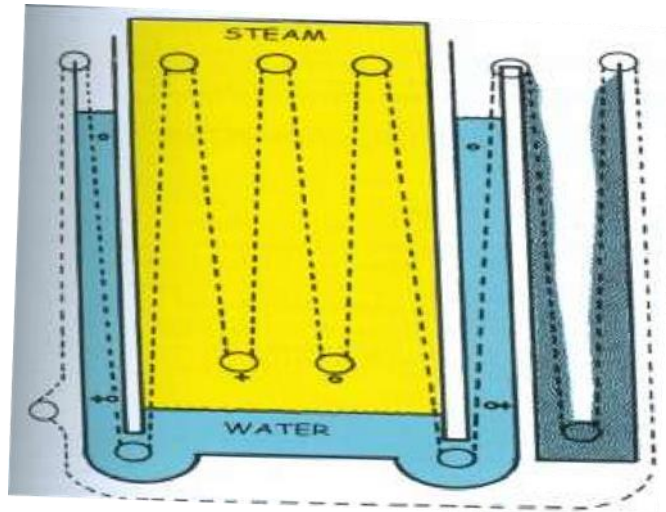

Fig. Hydrostatic retort

The characteristics of hydrostatic retort are as follows.

- It operates with steam as the processing medium.
- The processing chamber (also known as steam dome) is maintained at constant temperature.
- It has a continuous conveyor chain that transports containers at a constant rate.
- There is minimal container agitation during processing.

(However, some use cascading water with over pressure as the processing medium and some provide container rotation or rocking during processing.)

- Two, four, six or eight pass hydrostatic retorts are common.
- Pressure within the chamber is maintained and counterbalanced by the weight of water in the feed and discharge gates.
- To increase the temperature, the pressure must increase and thus height of water column must increase.
- For the processing chamber temperature as 121°C , we require 103.4 kPa pressure in the chamber, i.e. the height of water column in the feed and discharge legs must be 11.3m above the steam-water interface.

Continuous sterilizer:

In the continuous sterilizers, the cans enter and exit the sterilizer in a continuous manner.

Continuous rotary retort

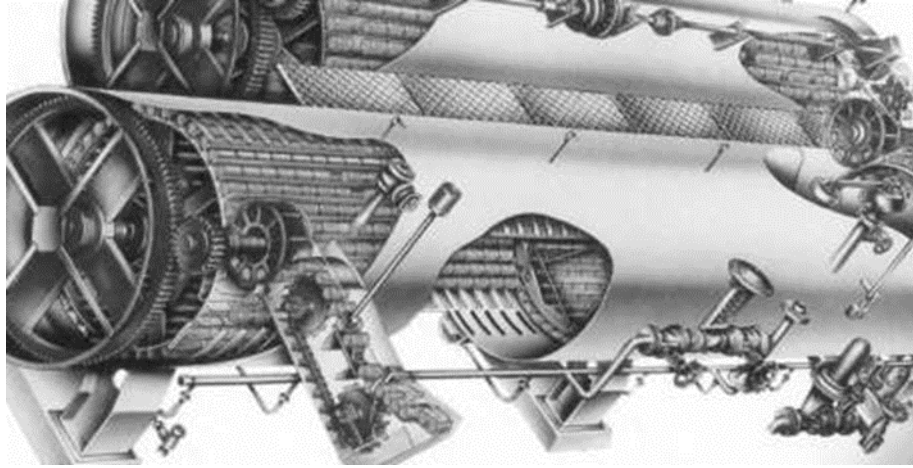

Fig. Continuous rotary retort

The characteristics of continuous rotary retort are as follows.

- There is continuous container handling and intermittent product agitation.
- The retort system is constructed of a series of cylindrical vessels called shells (typically 1.5 m diameter).
- Processing and cooling in separate shells connected by transfer valves.
- To maintain pressure in the shells, containers enter and exit through self-sealing inlet and discharge valves.
- Agitation occurs when the containers roll on the bottom of a shell.
- Product agitation increases rate of heat penetration, allows use of higher processing temperature (up to 138°C), and improves product uniformity and quality.
- Large initial investment and additional critical factors to monitor and control.
- Retorts will accommodate a limited range of both length and diameter of cylindrical container sizes due to the physical restrictions imposed by reel steps, spacing of the spiral and other factors.

General problems in in-bottle sterilization:

There are two kinds of problems in heat treatment

1. Heat has to pass through the container first before it goes into the milk.
2. Use of glass as container material may cause some auxiliary problems.

While processing milk in bottles, a ring of white solids is found on wall of the bottle at edges of milk surface. It could be due to excessive foam formed during bottle filling operation. It can be avoided by rotation or violent shaking of the bottle during heating and cooling cycle.

Important accessories in retorts:

The following are the important accessories in a retort.

- Air vent
- Temperature recorder/ thermometer
- Pressure gauge

They should perform accurately so that damage to the product and to the people and machines are avoided.

Steam requirement for retorting:

Assuming that milk bottles are loaded at 70°C and sterilised at 113°C by steam with a heat capacity of 2320 kJ/kg, the steam requirement is about 0.1 kg steam for each litre of milk. However, in practice, the usually steam capacity ranges between 0.2-0.6 kg of steam per litre of milk according to the plant characteristics.

Bottle cooling by natural air:

As it has been mentioned earlier, the bottles have to be immediately cooled after processing so that the product is not overcooked and the quality is not impaired. However, it is essential that any type of thermal shock is avoided during the cooling process. First the steam is vented outside to reduce the pressure and temperature inside the retort. Then cooling of the containers is done either by air or water.

Controlled water cooling within the sterilizer is practised in commercial canning for metal cans, but not for glass bottles, as they may break.

ULTRA HIGH TEMPERATURE STERILIZATION:

The main features of Ultra High Temperature (UHT) or aseptic processing are as follows.

- Temperature of 135-150°C is maintained for a few seconds.
- So the product is treated in a continuous heat exchanger.
- Causes much less chemical change than the conventional sterilization process.

The classification of UHT sterilization processes as regards to different types of heating medium and methods are given in Fig.

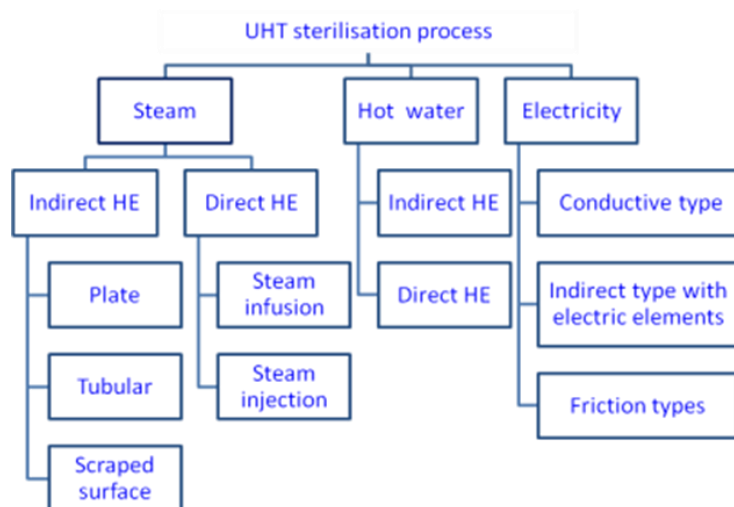

Fig. Classification of UHT sterilization process

The flow chart of a UHT sterilization process is shown in the following Fig.. We have already discussed about the functions of different parts in the pasteurization section. In this case, the temperature is increased to 135-150°C and the holding time is less. Hence the length of holding tube is much smaller than the HTST pasteurization methods.

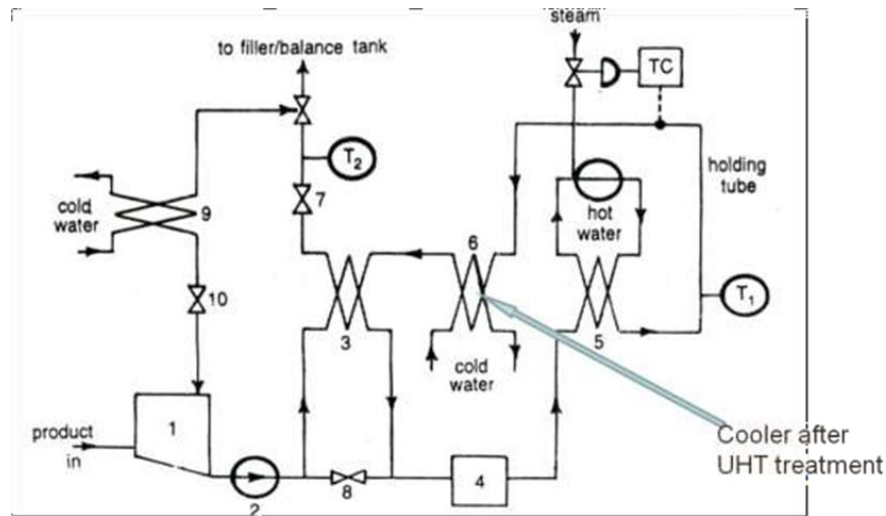

Fig. UHT sterilization process (indirect heating type)

- (1) level-controlled balance tank (2) centrifugal pump (3) plate heat exchanger (4) homogenizer (5) heat exchanger (6) cooling section (7) restriction (8) by-pass valve (9) cooler (10) back-pressure valve

In the heating chambers, a high pressure is maintained on the milk side. The following Fig. gives a cause-effect diagram to explain why high pressure is required in the chambers.

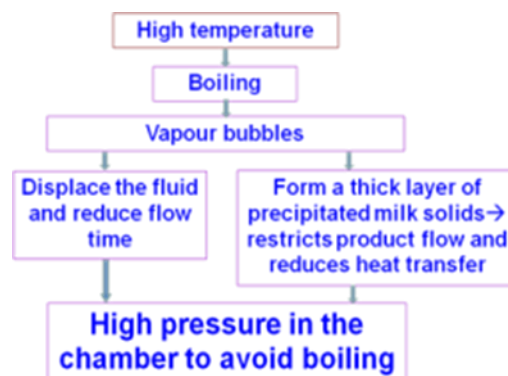

Fig. Why high pressure is required in chambers

•As can be seen from the above Fig., high temperature maintained in the chambers cause boiling of milk and it forms vapour bubbles. The vapour bubbles have two effects, i.e., they displace the fluid and reduce the flow time; and they also form a thick layer precipitation of milk solids which restricts product flow and reduces heat transfer. Therefore, high pressure is required in the chamber to avoid boiling.

•At a temperature of 135°C and 150°C, a back pressure of about 2 bar and 3.75 bar are needed respectively. However, to prevent the separation of air at high temperature and formation of bubbles by the dissolved air, a back pressure over and above this is required,

i.e. internal pressures of about 4 bar is required, where the temperature may be above 140°C.

- Because of hydrodynamic pressure drop resulting from the product being pumped through the heat exchanger, higher pressure may be reached in other parts. This highest internal pressure may reach 6-8 bar.

UHT Sterilization in plate heat exchanger:

The plate heat exchangers are most commonly used in indirect type UHT heat sterilization. The plate heat exchanger must be able to withstand the high pressure.

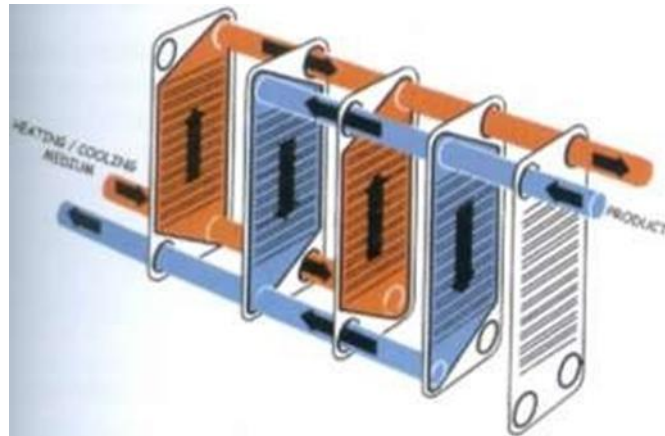

Fig. Schematic diagram of a plate heat exchanger

To withstand these severe conditions of temperature and pressure, the gasket materials used with plates must be more sophisticated and expensive. Medium nitrile rubber is suitable for temperatures up to about 138°C. For higher temperatures (i.e. up to 155-160°C) resin-cured butyl rubber is suitable.

UHT sterilization with direct type heat exchanger:

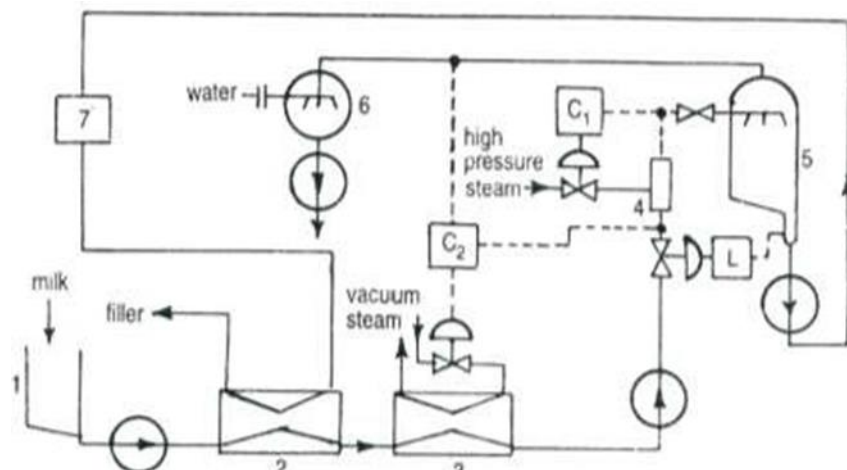

Fig. shows the flow sequence in UHT sterilization with direct steam injection type heat exchanger.

- (1) level-controlled balance tank
 - (2) pre-heater (regenerator)
 - (3) heat exchanger
 - (4) steam injector
 - (5) expansion cooling vessel
 - (6) water jet/ surface condenser
 - (7) homogeniser
- (L) controller (C) temperature controller

Direct heating injection type system:

- The direct steam injection can increase the temperature of milk within fraction of a second and the holding time required is very less.
- The amount of steam to be condensed per kg product is about 0.11 kg or 11 per cent of the product.
- If all this added volume is to be removed in cooling vessel, a small error in the balance will have a considerable practical and commercial effect on the total product volume leaving the plant.
- For accurate compensation, the temperature of vapour leaving the flash vessel should be slightly higher than that of the product before mixing with steam.

Ways to reduce fouling

- A high surface finish of the heat exchangers is required as rough surface provides more surface to which material can stick on.
- The higher the liquid flow velocity, the less is the amount of fouling.
- A lower temperature differential between the heating medium and the product leads to less fouling (a lower differential lowers the temperature at the heating surface-product interface).
- Preheating: The amount of deposit is less if the product is first heated to 75°C or above and held at that temperature for 10 min or more. (There will be reduced deposit due to denaturation of serum proteins and insolubilization of the milk salts by preholding at temperatures between 85°C and 110°C.)

Back-pressure to reduce fouling: It is necessary to maintain a sufficient back-pressure on the product not only to prevent boiling at the highest temperature within the heat exchangers but also to prevent the separation of dissolved gases which are normally present in the product. Thus ultimately it helps to minimize fouling. The use of a high back pressure to reduce fouling is now standard practice in the UHT heat exchangers.

A back pressure of at least 1 bar above that corresponding to the highest temperature in the heat exchanger is required.

- The use of pressurized hot water tends to induce less fouling than steam heating and high product velocities also help to reduce deposits.
- This latter approach is limited to holding time and pressure drop considerations.

Lecture 8

Evaporation of Food

Evaporation refers to the partial removal of water from a liquid food material through vapourisation.

Separation is achieved by exploiting the difference in volatility between water and solutes.

Generally, 80% water is removed and 20% is left.

Objectives of evaporation:

- ✓ To pre-concentrate foods prior to drying, freezing or sterilization, and hence to reduce weight and volume.
- ✓ To reduce container size and cost involvement in storage, transportation, handling and packaging.
- ✓ To save energy in subsequent operations.
- ✓ To enhance shelf life.

Basic functions of an evaporator:

- ✓ Transfer of heat from steam to the food
- ✓ Vapourisation of water
- ✓ Removal of fluid droplets from the vapour before it leaves the evaporator.

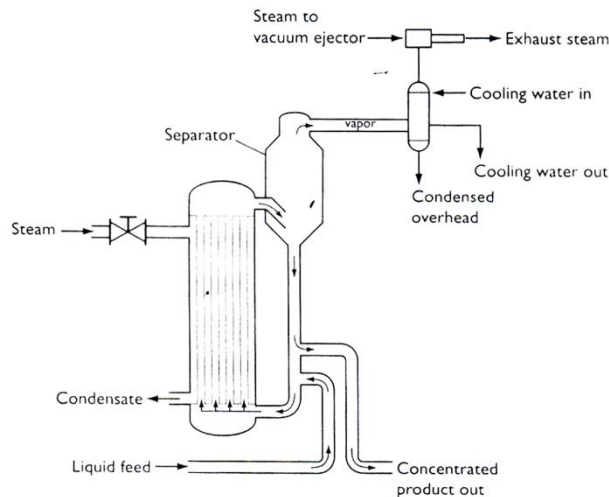

Fig. Basic parts of an evaporator

Types of evaporators:

Natural circulation types

- ✓ Open or closed pan evaporators
- ✓ Short tube (Calandria) evaporators
- ✓ Long tube vertical evaporator: Climbing/ Falling film type

Forced circulation types

- ✓ Mechanical (or agitated) thin film evaporator
- ✓ Plate evaporator
- ✓ Expanding flow evaporators
- In forced circulation evaporators, a pump or scraper assembly moves the liquor, usually in thin layers. It gives higher heat transfer rates and short residence times. It also gives more compact equipment and higher production rates.

Short tube evaporator:

- Hell and tube type HE
- Tube bundles (Vertical/ Horizontal)
- Steam generally in the shell
- Central down-comer large dia tube
- Liquid moves due to vapour pr difference
- Baffles at top
- Steam at atm. pr. or elevated pr (up to 2.8 kg/cm²)
- Single pass / Multi pass
- Basket evaporator
- External calandria evaporator

- Low viscosity products

Long tube evaporator:

Rising film type	Falling film type
Tube dia: 5 cm	5-25 cm
Flow by buoyancy	Flow by gravity
Liquid almost heated to boiling point	Distributor at the top
Flow velocity increases in the rising column	Flow velocity at the end 200 m/sec
Return leg for recirculation	Recycling possible
Baffle/ vapour separators at top	Vapour separator at bottom
Low viscosity product: 0.1 Ns/m ² Effective for foaming fluids	More viscous foods, heat sensitive foods
Residence time is 3-4 min	5-30 sec residence time

Forced circulation evaporators:

- ✓ Horizontal or vertical heat exchanger
- ✓ Horizontal may have two passes
- ✓ Forced at air velocity of 2-5.5 m/s
- ✓ Tubes are under static head so that no boiling in tubes
- ✓ Vapour separator- Deflector plate/ baffle
- ✓ Part of liquid is recirculated
- ✓ Suitable for viscous foods 20 Ns/m²

Agitated thin film evaporators:

- ✓ Steam jacketed vessel
- ✓ High speed rotor, fitted with short blades along its length
- ✓ Film thickness: 1.25 mm for scraped surface
 - 0.25 mm for wiped surface
- ✓ Residence time 0.5-100 s
- ✓ Extra capital / running cost (due to mechanical agitation, and more precise alignment)
- ✓ Only single effect is possible
- ✓ Up to 20 Ns/m²
- ✓ Used mostly for finishing of high viscous products

Centri-therm conical evaporator:

- ✓ Feed from a central pipe to underside of rotating cone
- ✓ Liquid moves by centrifugal force
- ✓ Film thickness : 0.1 mm
- ✓ Residence time : 0.6-1.6 sec
- ✓ Condensed steam flung from rotating cones and hence no boundary layer □ high heat transfer rate

- ✓ High viscous fluid 20 Ns/m²

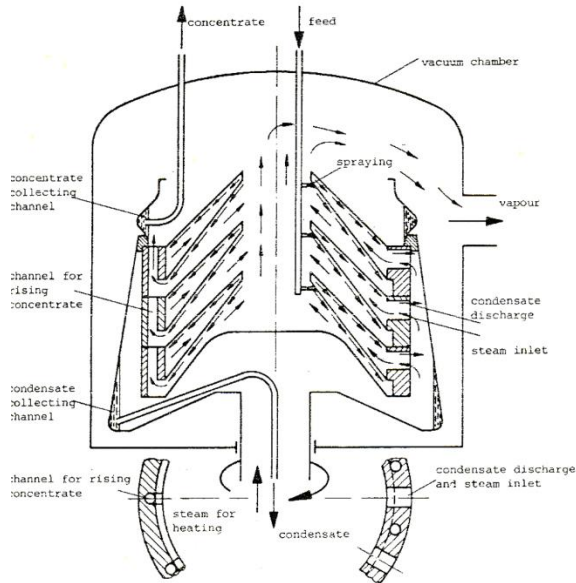

Fig: Centri-therm conical evaporator

Expanding flow evaporators:

- ✓ Stack of inverted cones
- ✓ Steam fed down in alternate channels
- ✓ Liquid moves by vapour pressure upward
- ✓ Vapour-concentrate mixture leaves tangentially
- ✓ Special design of shell, which induces cyclone effect, separates the vapour concentrate mixture
- ✓ Reduction of flow area of condensing steam maintains high heat transfer rate

Lecture 9

Mass and Energy Balance in a Evaporator

A. Duhring Plot

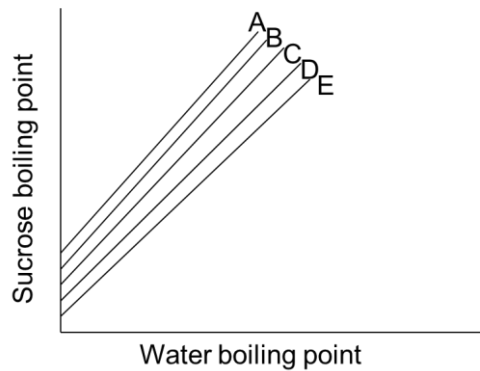

Duhring plot for sucrose for various sucrose concentrations per 100 g of water: line A: 1000g, line B: 800 g, line C: 600g, line D: 400g, line E: 200g

B. Empirical equations:

$$-\ln(X_w) = \frac{\lambda'}{R} \left(\frac{1}{T} - \frac{1}{T_b} \right)$$

Where

X_w is the mole fraction of solvent,

λ' is molal latent heat,

R is Universal gas constant (8.31434 kJ/kg-mole-°K),

T and T_b are boiling point of pure water and solution under consideration respectively.

$$\Delta T_b = 0.51 m$$

Where ΔT_b is the boiling point rise of solution with molality 'm' above the boiling point of pure water at the given absolute pressure.

Factors affecting the rate of heat transfer

- Temperature diff. between the steam and boiling liquid
- Deposits on heat transfer surfaces (fouling)
- Boundary films

Factors affecting economy of operation

- Loss of concentrate (Foaming and entrainment)
- Energy expenditure

Other factors affecting evaporation process

- Solubility limit of food material: crystallization (when the product is taken out and cooled crystallization occurs).
- Temperature sensitivity of material
- Pressure and temperature

Factors affecting the selection of an evaporator

- Operating capacity (how much water to be evaporated per hour)
- Degree of concentration required (as % of dry solids in the product)
- Frequent changes in the product or capacity
- Heat sensitivity of the product in relation to the residence time and temperature of evaporation
- Requirement of volatile recovery facilities
- Ease of cleaning
- Reliability and simplicity of operation
- Size of evaporator in relation to its capacity
- Capital and operating costs in relation to capacity and product quality.

Mass and energy balance in an evaporator:

$$F = P + V$$

$$F \cdot X_f = P \cdot X_p + V \cdot X_v$$

$$F \cdot X_f = P \cdot X_p$$

$$V = F - P = F - F \left(\frac{X_f}{X_p} \right) = F \left(1 - \frac{X_f}{X_p} \right)$$

$$F \cdot H_f + W_s \cdot H_s = V \cdot H_v + P \cdot H_p + W_s \cdot H_{sc}$$

$$F \cdot C_f \cdot T_f + W_s \cdot \lambda = V \cdot h_v + P \cdot C_p \cdot T_p$$

$$W_s \cdot \lambda = V \cdot h_v + P \cdot C_p \cdot T_p - F \cdot C_f \cdot T_f$$

$$W_s \lambda = F \left(\frac{X_f}{X_p} \right) C_p T_p + F \left(1 - \frac{X_f}{X_p} \right) H_v - F C_f T_f$$

$H_v = H_v^* + \phi$, where ϕ is the boiling point rise

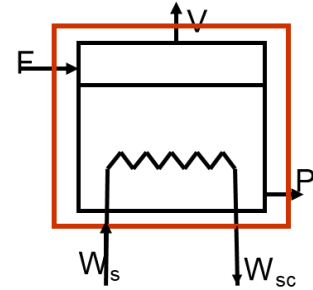

$$W_s \cdot \lambda = q = U \cdot A \cdot \Delta T$$

Selection of the system and boundary in an evaporator for mass and energy balance:

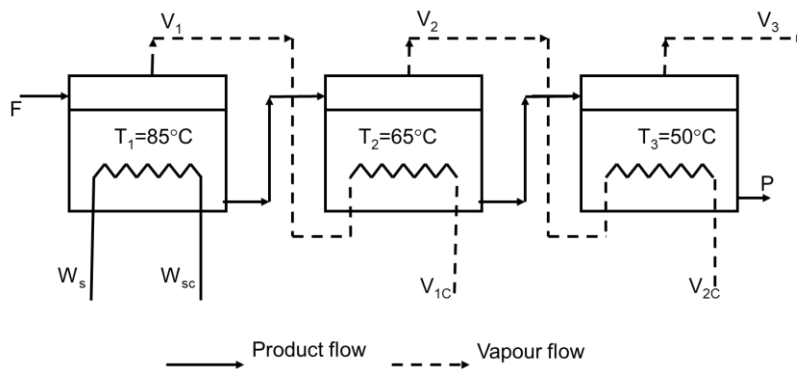

In a triple effect evaporator:

$$Q_1 = U_1 \cdot A_1 \cdot \Delta T_1, \Delta T_1 = (T_s - T_1)$$

$$Q_2 = U_2 \cdot A_2 \cdot \Delta T_2, \Delta T_2 = (T_1 - T_2)$$

$$Q_3 = U_3 \cdot A_3 \cdot \Delta T_3, \Delta T_3 = (T_2 - T_3)$$

Now, $W_s \cdot \lambda = Q_1 = Q_2 = Q_3$ (assuming no boiling point rise)

$$\frac{\Delta T_i}{\sum \Delta T} = \frac{1/U_i}{1/U_1 + 1/U_2 + 1/U_3}$$

PROBLEMS

In the manufacture of jam, the crushed fruit is mixed with sufficient sugar to give a mixture of 45 parts of fruit to 55 parts of sugar. The mixture is then evaporated until the soluble solids are 67%. What yield of jam is expected from a fruit which has 14% soluble solids.

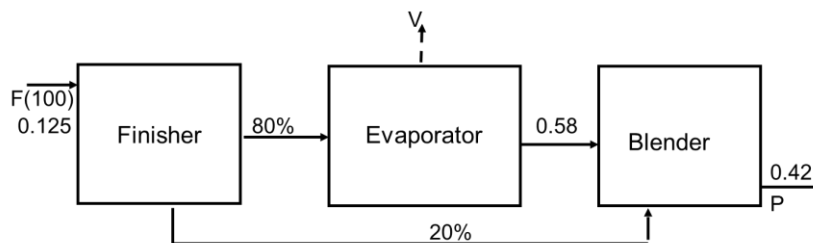

Calculate:

- The weight of water evaporated per 100 kg of fresh extracted juice fed to the system
- Concentration of solids in each stream leaving the finisher.
- The weight ratio of concentrated and unconcentrated juice in the final product.

Lecture 10

HOMOGENIZATION

What is homogenization of milk

Homogenized milk is that which has been treated in such a manner as to ensure breakup of the fat globules to such an extent that after 48 hours of storage, no visible cream separation occurs on the milk in a quart bottle, or, proportionate volumes in containers of other sizes does not differ by more than 10% from the fat percentage of the remaining milk as determined after through mixing.

To achieve this, we should have the fat globules in small and uniform sizes. The process of breaking up the fat globules to very small sizes in order to prevent cream formation is known as homogenization. The equipment used for the same is known as homogeniser. The fat globules present in normal milk vary from 0.1 to 3 or 4 microns depending upon the breed of cows and various other factors. By homogenization, we break up the fat globules to below 2 micron sizes.

Homogenization of milk also serves the following purposes.

- Prevents cream formation.
- Increases milk viscosity, it gives richer appearance to tea or coffee.

- Fat globules do not rise readily and there is no necessity for agitating the milk before serving.
- Prevents churning of fat during rough handling or excessive agitation.
- Reduces curd tension, i.e. forms a soft curd when homogenized milk is coagulated, i.e. milk becomes more palatable due to brighter appearance, heavier body and richer flavor.
- Milk becomes more digestible partly because of the smaller fat globules and partly because of the lower curd tension. The homogenized milk can be recommended for infants.
- Reduces the chances of separation of fat during the manufacture of evaporated milk and ice-cream, it gives a smoother texture of the product.
- Homogenizer can be used to prepare reconstituted milk by mixing butter oil or butter with skim milk.
- The milk becomes less susceptible to oxidized flavor development.

However, if we are interested in recovery of fat, then homogenized milk should not be taken. Fat recovery from homogenized milk is difficult.

Four different forms of fat globules in milk

- Single globules unattached.
- Clusters, consisting of two or more globules loosely attached.
- Clumps, consisting of two or more globules tightly clumped together so that the individual appearance of the globules is almost lost.
- Churned or butter particles in which the individual globules have lost their identity.

A homogenizer should break up all the clusters, clumps and butter particles present in un-homogenized milk.

THE HOMOGENIZER

The homogeniser consists of a high pressure pump fitted with a minute orifice having an adjustable opening through which fluids are forced at a very high pressure. Thus the fat globules are reduced in size.

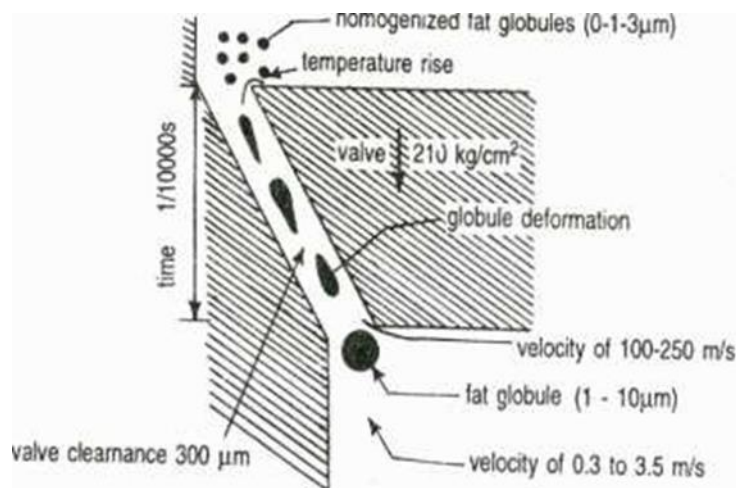

Fig. Working principle of a homogenizer

In actual practice most valves employ a combination of three principles (following Fig.). The homogenization can occur due to shear or due to disruption. The shearing action occurs among the fat globules and in the narrow opening through which the milk is forced to pass. The disruption occurs at the breaker ring and also due to sudden pressure drop as the fluid leaves the valve.

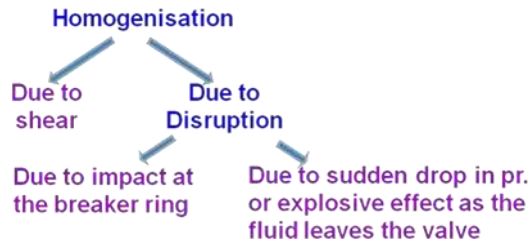

Fig. Types of forces acting during homogenization

Proper dispersion is equally important.

- Some homogenizers may give excellent break up, but the dispersion is very poor, resulting in excessive clustering and clumping and even churning.
- This cause the development of excessive viscosity, which sometimes makes the product very difficult to pump or cool.

In addition to other factors, the size and shape of the orifices are also affected by the volume of milk to be handled per unit time and by the viscosity of product.

Main components of a homogenizer

The main parts of a homogenizer are shown in the following Figs.

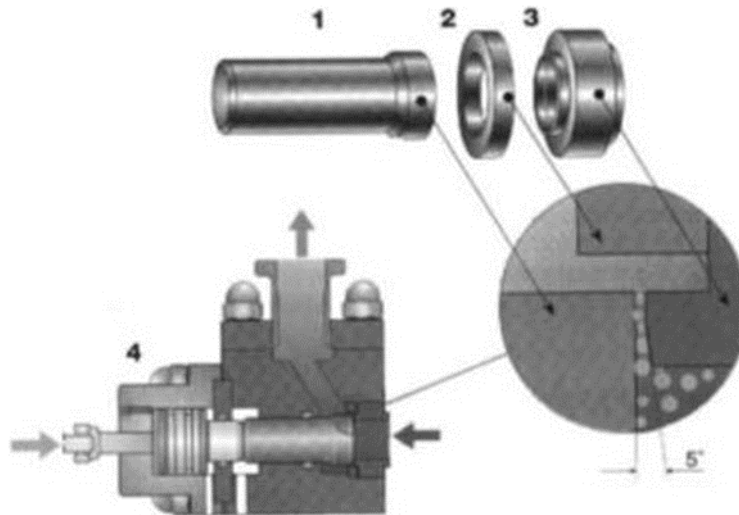

1. Forcer
2. Impact ring
3. Seat
4. Hydraulic actuator

Fig. Components of a single-stage homogenization device

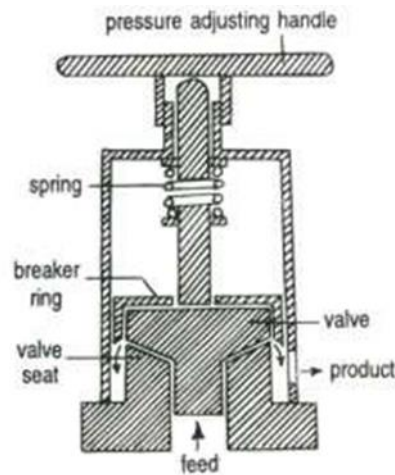

Fig. Main components of a homogenizer

As can be seen from the above figures, the main components of a homogenizer are: pump, homogenizing valve, breaker ring, tension spring and the valve sheet.

Homogenizing valve:

- The homogenizing valve is the heart of the homogenizer.
- This may be of different shapes and sizes.
- Most valves are of poppet type, which have a breaker ring so that the fluid strikes the inner surface of the breaker ring perpendicularly as it leaves the orifice formed by the conical shaped valve and seat.
- The valve is held by a heavy spring having adjustable tension. As the fluid pressure comes against it, the valve rises few thousandth of an inch to form a narrow annular opening (orifice).

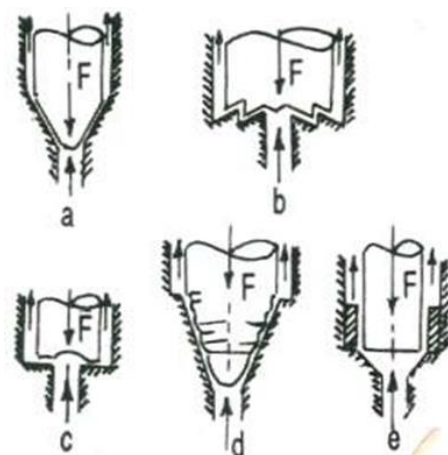

Fig. Types of homogenizing valves

- The valve parts are subjected to extreme abrasion because of the high velocity and pressure of the fluid as it passes through the valve. So they must be constructed of extremely tough and wear resistant hard metals such as stellite.

- The valve size must be suited to the capacity of the machine. Larger valves cause excessive clustering and too small valves may not give proper break up.
- Any slight grooving due to wear and tear may reduce the effectiveness. Hence, two valves are used in series, which is called a two stage homogeniser. A two stage homogenizer is shown in the following Fig..
- The principal advantage of the two stage method is that it improves dispersion of fat globules and is useful in controlling viscosity of cream and ice cream mix.

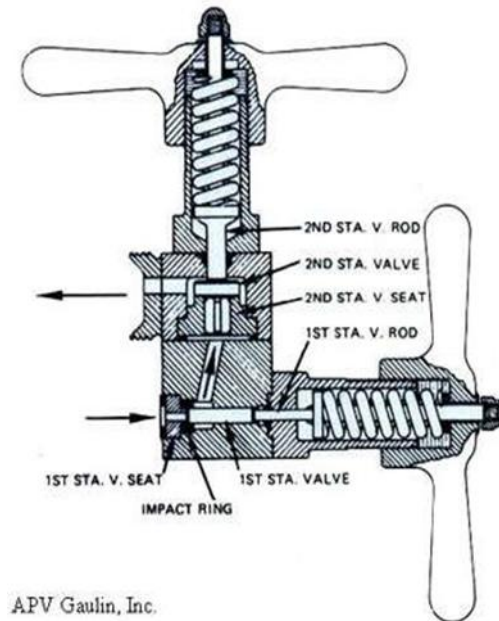

Fig. A two stage homogenizer

Homogenizing pump:

The homogenizing pump imparts the desired pressure required for homogenization.

The following Table gives an understanding on the effect of homogenization pressure on fat globules break up.

Table. Effect of homogenization pressure on fat globules break up

Pressure (psi)	Range of size of fat globules micron	Average size of fat globules in micron
500	1 to 14	2.39
1,000	1 to 7	1.68
1,500	1 to 4	1.40
2,000	1 to 3	1.08
2,500	1 to 2.5	0.99

3,000	0.5 to 2	0.76
-------	----------	------

- As can be seen from the table, the homogenization of milk should be carried at 2000 to 3000 psi (136-204 kg/cm²) pressure.
- For milk with up to 6% fat content, usually 136-170 kg/cm² (2000-2500 psi) in a single stage is sufficient.
- Higher pressure may increase the tendency for the milk to curdle when cooked, due to the increased destabilizing effect on the milk proteins.
- For products with more than 6% fat, 2-stage homogenization is needed to prevent fat clumping: 136-170 kg/cm² at the first stage and 34 kg/cm² at the second.
- New modern valves use low pressure, even 1/3rd less than that of conventional valves and furthermore they maintain efficiency without frequent valve grinding, since the wearing out (the wire valve) is replaced every day.

The homogenizer is always required to maintain steady pressure because

- The shearing effect of the valve changes with the velocity of the fluid and, for a certain valve, shearing effect can be acceptable only at a given velocity.
- With fluctuating pressure, the velocity will fluctuate, thus causing irregular results, non-uniform products and thereby decreasing the efficiency.
- A single plunger pump will develop pulsating pressure, and hence it is very common to have 3-plunger positive displacement pump, or, triplex pump for the purpose.
- The overlapping of strokes tends to give a reasonably uniform pressure (there is about 20% pressure variation).

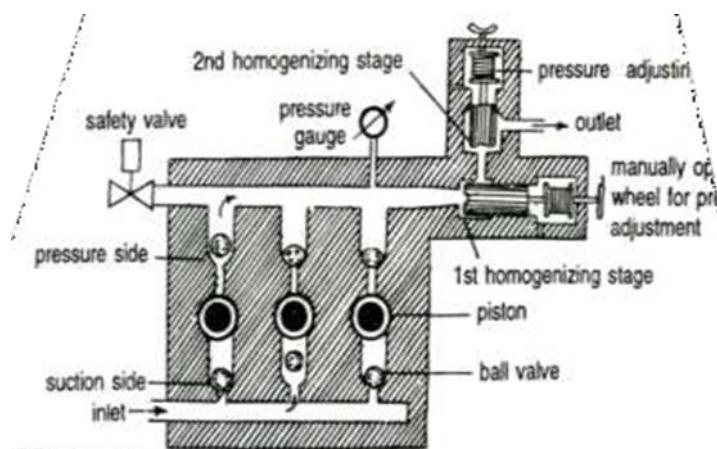

Fig. Typical two stage homogenizer with 3-plunger pump Temperature during homogenization

The following points are important in this context.

- The melting point of fat is 33°C.
- For inactivation of lipase, we require 55°C.
- The viscosity of milk during homogenization should also be optimum.
- Therefore, to inactivate the enzyme lipase and to reduce the tension between globules, the milk is heated to 65-70°C for homogenization.

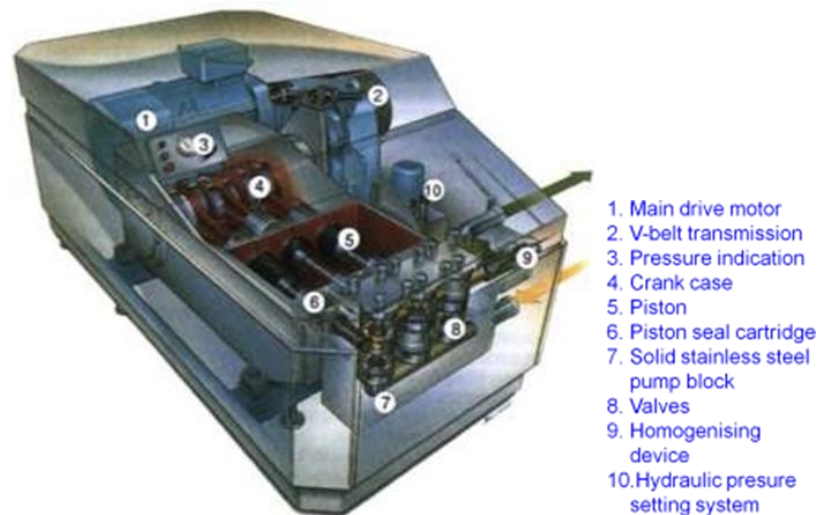

Fig. A homogenizer showing different components

Effect of different operational parameters during homogenization

- High temperature homogenization causes reduced clustering, reduced viscosity, and better break up of fat globules.
- Low temp (50-55°C) homogenization reduces break up and offers more resistance to flow.
- Increase in pressure causes finer break up of fat globules, increases tendency to form clusters or clumps.
- Irregular pulsating pressure reduces efficiency.
- High temperature and pressure cause excessive casein destabilization.
- High acidity causes more viscosity, and tends to form clusters or clumps.
- Homogenization efficiency may be reduced if the produce is not held at proper temperature for 30 min.
- Minute imperfections in the homogenizing valve allow large globules to slip through and thereby prevent effective homogenization.
- The fat globules are surrounded by a membrane of about 10 µm thick consisting of approximate 48% protein, 33 % phospholipids and 19% water.
- When the fat globules are reduced to smaller sizes in a homogenizer, new membranes are automatically formed, provided the membrane material does not become limiting.

- The requirement of membrane material becomes high when the fat globules are reduced to very small sizes.

- In certain situations, e.g. for the preparation of the reconstitution of milk from skim milk powder and butter oil, some amount of fresh milk is required. The fresh milk supplies the desired amount of phospholipids to the new membranes, which are formed during the homogenization of butter oil.

Judging the efficiency of homogenization

- One of the best methods is to examine a sample under a high power microscope and to note and analyze the size of the fat globules.

- The product is accepted as homogenized if 85% of the fat globules are less than 2 μm size.

Care and maintenance of homogenizers

- The suction and discharge pipes need to be kept in good condition otherwise the homogenizer will pulsate badly, yielding an inferior product.

- The homogenizing valve, being the heart of the machine, must be kept smooth. When the valve or the seat shows grooves on the wearing surface, they should be returned to the factory for resurfacing of the valve and seat.

- Care should be exercised to keep the suction line as short as possible.

- All joints should be carefully finished to eliminate any possibility of air leakage.

- In installations where suction lines are longer than 5 m, it is recommended that a feeding pump be installed.

Lecture 11

CREAM SEPARATION

The cream separation is a very important unit operation in dairy industry. The cream or fat is taken out of milk for standardisation purpose. Besides, cream is also required to prepare some value added products as ghee, butter, etc. Cream is usually separated from milk by the centrifugation process.

Centrifugation:

Sometimes gravity separation may be too slow because of the closeness of densities of the particle and the fluid, or because of the association forces holding components together, as in emulsions like whole milk. In that case centrifugation helps in separation of the components on the basis of differences in their densities.

- The centrifuge increases the forces on particles many fold.

- Thus the particles that do not settle readily or at all in gravity settlers can often be separated from fluids by centrifugal force.

- The relative settling velocities of small particles are not changed, but the disturbing effects of Brownian motion and free convection currents are overcome.

The equipment using this principle of separation is known as a centrifuge. The centrifuges are used for:

- separation of immiscible liquids,
- clarification of liquids by removal of small amounts of solids, and
- for removal of solids from liquids

Centrifuges are also used for centrifugal filtration, where the centrifugal force is used (not the pressure difference) to separate the solids through a filter medium. The major applications of the centrifuges are shown in the following Fig.

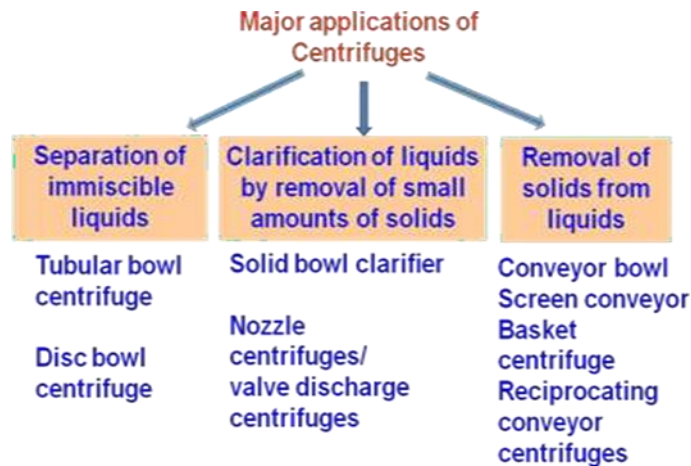

Fig. Major applications of the centrifuges

As can be observed from above Fig., for cream separation, two types of centrifuges are used, namely, the tubular bowl centrifuge, and the disc bowl centrifuge.

Tubular bowl centrifuge:

The basic characteristic features of a tubular bowl centrifuge are as follows.

- It consists of a vertical cylinder (or bowl), typically 0.1-0.15 m in diameter and 0.75 m long.
- Rotates inside a stationary casing (15000-50000 rev/min depending on the diameter).
- Tubular bowl centrifuges, which develop about 13000xg force, are also known as super centrifuges.
- Feed liquor is introduced continuously at the base of the bowl and the two liquids are separated and discharged through a circular weir system into stationary outlets.
- Some narrow centrifuges known as ultra-centrifuges have a diameter of 75 mm and very high speeds of about 60000 rev/min.



Fig. A tubular bowl centrifuge

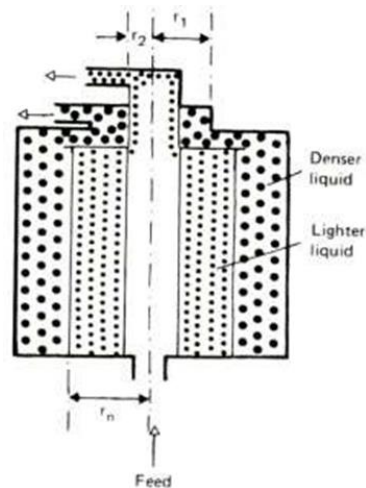

Fig. Working principle of a tubular bowl centrifuge

Disc bowl centrifuge:

The characteristic features of a disc bowl centrifuge are as follows.

- It consists of a conical bowl (0.2-1.2 m diameter), which contains a stack of inverted metal cones.
- The cones rotate at 2000-7000 rev/min.
- There is a fixed clearance between cones: 0.5-1.27 mm; and they have matching holes which form flow channels for liquid movement.
- Feed is introduced at the base of the disc stack.
- Due to the centrifugal force, the denser fraction moves towards the wall of the bowl, along the underside of the discs. The lighter fraction moves towards the centre along the upper surfaces.

- Both liquid streams are removed continuously by a weir system at the top in a similar way to the tubular bowl system.



Fig. A disc bowl centrifuge

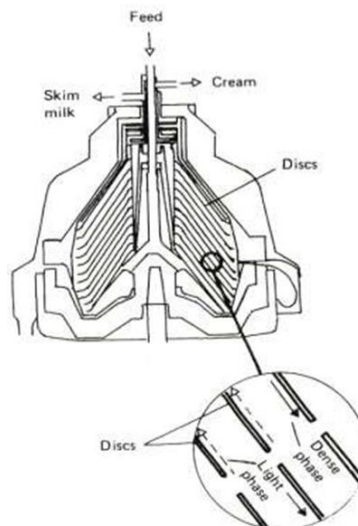

Fig. Working principle of a disc bowl centrifuge

- Disc bowl and tubular centrifuges can have capacities even up to 150000 l/h.
- Better separation is obtained by the disc bowl centrifuge due to the formation of thinner layers of liquid.
- Periodic cleaning of deposited solids is required.
- The disc bowl centrifuge, in addition to being widely used for separation of cream from whole milk, is also used for clarification of oils, coffee extracts and juices, and separation of starch-gluten.

Domestic cream separator:

Small capacity domestic cream separators working on the principle of disc bowl centrifuges are also available. The following Fig. shows such a domestic cream separator with its basic component parts. The separator is operated by hand with the help of a handle fixed to it.

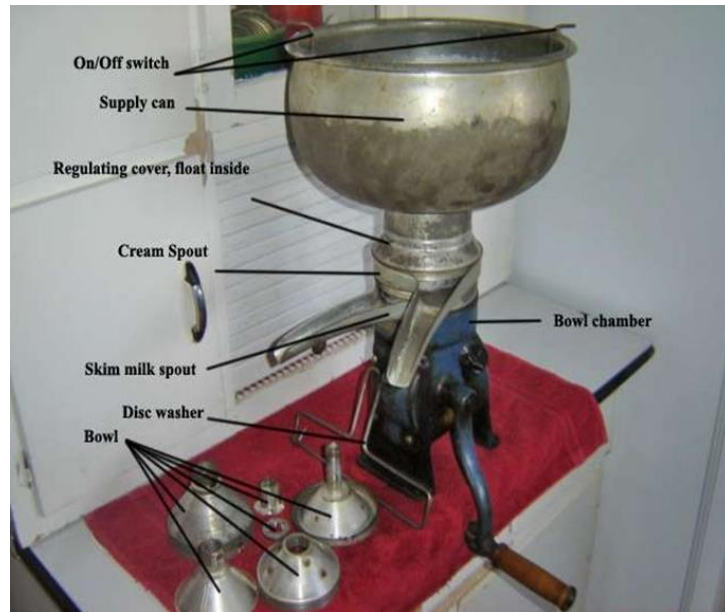

Fig. Domestic cream separator

Lecture 12

DRYING DRYING OF LIQUID AND PERISHABLE FOODS

Drying is one of the oldest methods of preserving food. To preserve perishable raw food commodity against deterioration or spoilage by reducing moisture content and thus by reducing water activity. To reduce the cost and difficulty of packaging, handling, transportation and storage by converting the material into a dry solid, thus reducing its weight and in most cases volume.

Equilibrium moisture / Free moisture/ Bound moisture/ Unbound moisture:

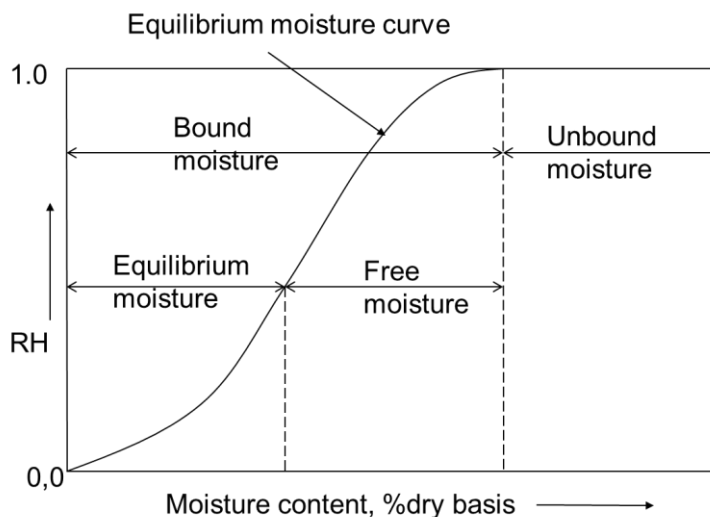

BASIC DRYING THEORY:

- ✓ Drying is a complex operation involving transient transfer of heat and mass transfer.
- ✓ Sensible and latent heat must be transferred to the food to cause the water to evaporate
- ✓ Physical changes that may occur include shrinkage, puffing, crystallization, and glass transitions.

- ✓ In some cases, desirable or undesirable chemical or biochemical reactions may occur, leading to changes in color, texture, odor, or other properties of the solid product.
- ✓ Drying curve usually plots the drying rate versus drying time or moisture contents.
- ✓ Three major stages of drying can be observed in the drying curve.
- ✓ Transient early stage, during which the product is heating up (transient period)
- ✓ Constant rate period, in which moisture is comparatively easy to remove
- ✓ Falling rate period, in which moisture is bound or held within the solid matrix.

Drying rate curve:

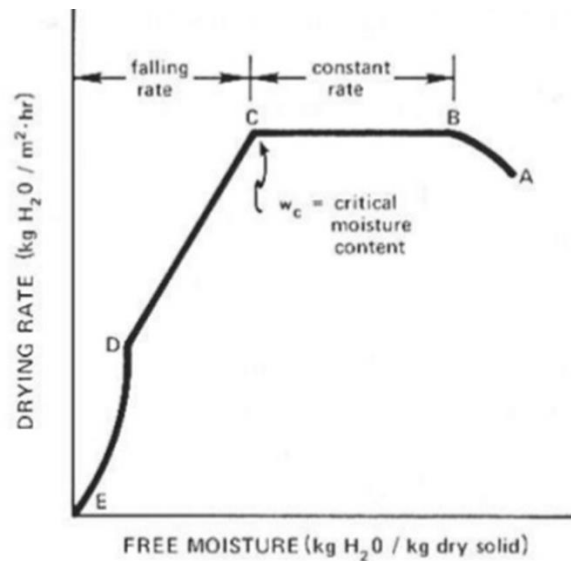

Constant rate:

- ✓ Section B to C of the curve, known as the constant rate periods, represents removal of unbound water from the product.
- ✓ The surface of the product is very wet and the water activity is equal to one.
- ✓ In the constant-rate period, the water is being evaporated effectively as a free water surface.
- ✓ The rate of removal of water can then be related to the rate of heat transfer, if there is no change in the temperature of the material and therefore all heat energy transferred to it must result in evaporation of water.

Falling rate:

- ✓ The falling rate period (from point C) is reached when the drying rate starts to decrease, and the surface water activity falls to less than one.
- ✓ At this point there is not enough water on the surface to maintain a water activity value of one.
- ✓ The rate of drying is governed by the internal flow of liquid or vapor.
- ✓ The falling rate period can be divided into two steps.
- ✓ First falling drying rate (C to D)
- ✓ Second falling drying rate (D to E)
- ✓ A first falling drying rate occurs when wetted spots in the surface continually diminish until the surface is dried (Point D).

- ✓ Second falling rate period begins at point D when the surface is completely dry and until the EMC is reached.

Transport of moisture within the solid may occur by any one or more of the following mechanisms of mass transfer:

- ✓ Capillary flow
- ✓ Liquid diffusion, if the wet solid is at a temperature below the boiling point of the liquid
- ✓ Vapor diffusion, if the liquid vaporizes within material
- ✓ Knudsen diffusion, if drying takes place at very low temperatures and pressures, e.g., in freeze drying
- ✓ Surface diffusion (possible although not proven)
- ✓ Thermal diffusion
- ✓ Hydrostatic pressure differences, when internal vaporization rates exceed the rate of vapor transport through the solid to the surroundings
- ✓ Combinations of the above mechanisms

SPRAY DRYING

The different parts of a spray dryer are shown in the following Fig.

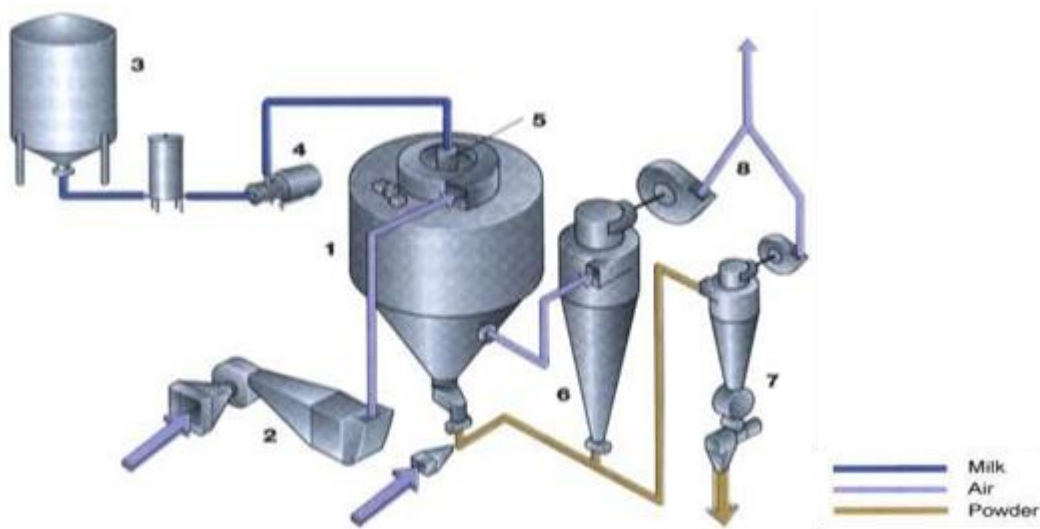

Fig. A spray dryer

(1) Drying chamber, (2) Air heater, (3) Milk concentrate tank, (4) High pressure pump, (5) Atomiser, (6) Main cyclone, (7) Transport system cyclone, (8) Air suction fans and filters

The main characteristics of a spray dryer are as follows.

- The liquid food dispersed in to a stream of hot gas
- Rapid vaporization of moisture
- Cylindrical drying chamber with a short conical bottom
- Other major parts: atomization system, air handling system, powder separation system

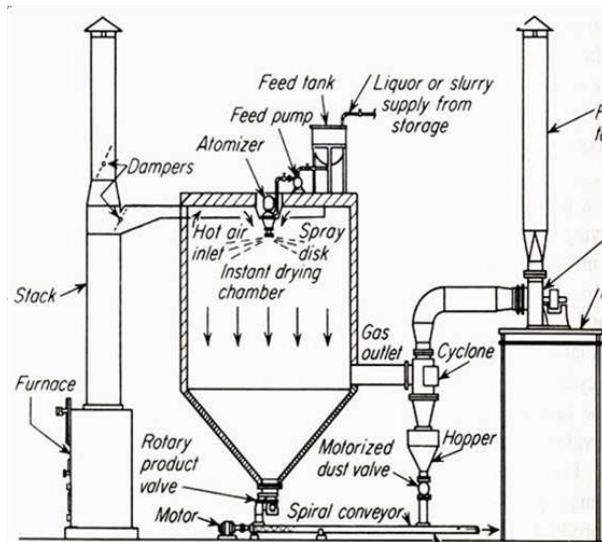

Fig. Components of a spray drying system

- Air temperature of 150 to 300°C. Air flow may be concurrent, counter current or a combination of both.
- Dryer chamber: few meters to 25-30 m long, diameters of 2.5-9 m, horizontal/ vertical
- Droplets exit the atomizer at about 50 m/s, but quickly decelerate to terminal velocity (0.2 to 2 m/s).
- Separation of powder is done first by gravitational settling, subsequently by a cyclone separator and then by a textile or bag filter.
- The food is usually fed in a pre-concentrated form to the drying chamber.
- Drying time is usually 5 to 100 seconds.
- The outlet air temperature varies between 50 and 100°C (drying temp-product temp-thermal stability)
- Can be of very high capacity (10000 kg dried milk/h)

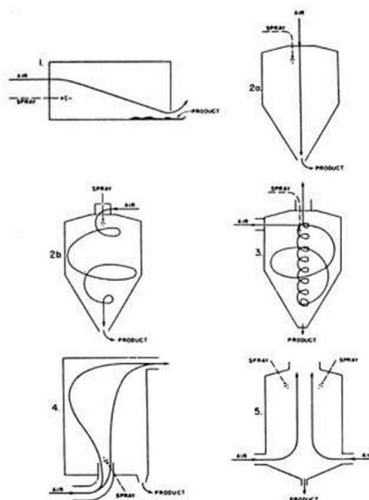

Fig. Air and fluid flow patterns in a spray dryer The atomization is caused by

- High pressure (700 to 2000 kPa) nozzle- It yields the droplets at 100 to 300 m.

- Centrifugal atomization (disc usually about 300 mm in diameter and rotates at 5000- 10000 rev/min, peripheral velocity 90-200 m/s): droplet size is 50-60 m
- By compressed air.
- Ultrasonic nozzle atomizer (first atomized by a nozzle atomizer and then by using ultrasonic energy to induce further cavitation)



Fig. A laboratory spray dryer Main advantages of spray drying

- Very short drying time
- Large scale continuous production
- Low labor costs
- Relatively simple operation and maintenance.

Disadvantages

- Much heat is lost in discharge gates
- High capital cost (due to atomization)
- Requirement for a relatively high feed moisture content
- Higher volatile losses.

The spray dryers are specifically used for:

Highly heat sensitive materials, e.g. instant coffee and tea, milk powders, soymilk powder, enzymes, cocoa, potato, ice cream mix, butter, cream, yoghurt, cheese, fruit juices, meat and yeast extracts, encapsulated flavors, wheat and corn starch products, egg powders, etc.

DRUM DRYING

It consists of drying of a slurry on a heated drum. The drum dryers can be of many types as shown in the following Fig.

Classification of drum dryers		
<u>Number of drums</u>	<u>Feeding device</u>	<u>Pressure or vacuum operation</u>
Single drum	Dip feed	Atmospheric type
Double drum	Splash feed	Vacuum type
Twin drum	Nip feed	
	Roller feed	

Fig. Classification of drum dryers

The main characteristics of a drum drying system are as follows.

- Slowly revolving drum(s) 0.6-3 m in diameter, 0.6 to 4 m long. (revolving at 1 to 10 rev/min)
- Steam is supplied to heat the surface of the drum
- Single drum, double drum or twin drum
- Dip feed / spraying / spreading or by auxiliary feed rollers
- Scraper or doctor blade to collect the product
- Drums may be enclosed in a vacuum chamber
- Drying capacity depends on drum area (Usually between 5 and 50 kg/m² of drying surface).
- High temperature drying (over 100°C)
- Rapid drying (Residence time 30 to 60 seconds)
- Exposure to high temperatures may cause browning or burnt flavour, protein denaturation
- Because of low thermal conductivity of food, thin layers of food are needed to conduct heat rapidly without causing heat damage.



Fig. A laboratory scale double drum dryer

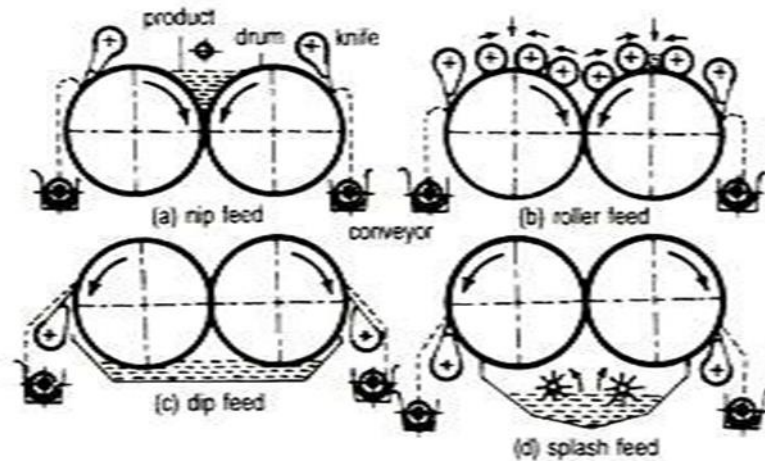

Fig. Feeding arrangements in a spray dryer

The drum dryers are also applied to:

- Dilute/concentrated solutions, moderately heavy slurries.
- Not suitable for solutions of salts with limited solubility or for slurries of abrasive solids that settle down and create excessive pressure between drums.
- Earlier used for drying of milk.
- In conduction dryers, typical heat consumption is 2000-3000 kJ/kg of water evaporated compared with 4000-10000 kJ/kg of water evaporated in hot air dryers.

FREEZE DRYING:

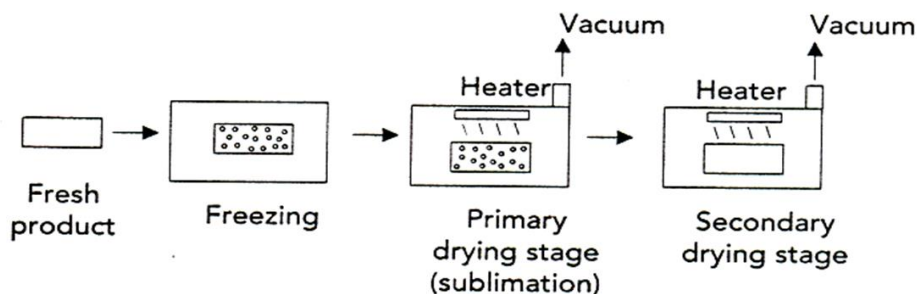

Fig. Stages of operation in a Freeze dryer

- ✓ Drying usually in two stages: primary stage: sublimation, secondary stage: vapourisation of unfrozen liquid water
- ✓ Rapid freezing: Plate freezer/ air blast freezer /Drum freezer
- ✓ Heat supply by combination of conduction and radiation
- ✓ Rapid sublimation, but temp below that of melting
- ✓ Typical pressure: 1 to 2 Torr
- ✓ Condenser
- ✓ Excellent product quality & flavour retention
- ✓ Cost twice that of vacuum belt drying, and 5 times of spray drying.

Effects on foods due to freeze drying:

- ✓ Freeze dried foods have a very high retention of sensory and nutritional qualities and a shelf life of longer than 12 months when correctly packaged.
- ✓ Aroma retention of 80-100% is possible.
- ✓ Texture of the foodstuff is well maintained; there is little shrinkage.
- ✓ The open porous structure allows rapid and full rehydration.
- ✓ There are only minor changes to proteins, starches or other carbohydrates
- ✓ Changes in thiamin and ascorbic acid content during freeze drying are moderate and therefore negligible losses to other vitamins.

Lecture 13 FILTRATION

Filtration is the removal of solid particles from a fluid by passing the fluid through a filtering medium (or septum) on which the solids are deposited. The fluid may be a liquid or a gas. The feed is usually modified to increase the filtration rate (by heating, recrystallizing, or adding a filter aid). Because of enormous variety of materials to be filtered and the widely differing process conditions, many types of filters are used.

Filters can be classified broadly as cake filters, clarifying filters and cross flow filters.

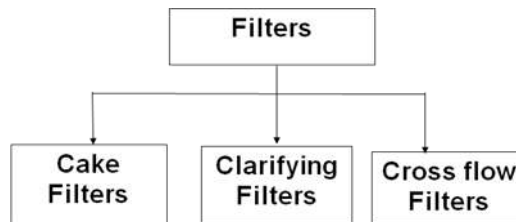

Fig. Classification of filters

Cake filters separate large amounts of solids in the form of cake or crystals or sludge. Here the filter medium is relatively thin compared with that of a clarifying filter. At the start of the filtration, some solid particles enter the pores of the medium and are immobilized, but soon they begin to collect on the septum surface. After this initial period, the cake of solids does the filtration, not the septum. As the cake builds up to an appreciable thickness on the surface, it has to be removed periodically.

Further categorization of cake filters are shown in the following Fig.

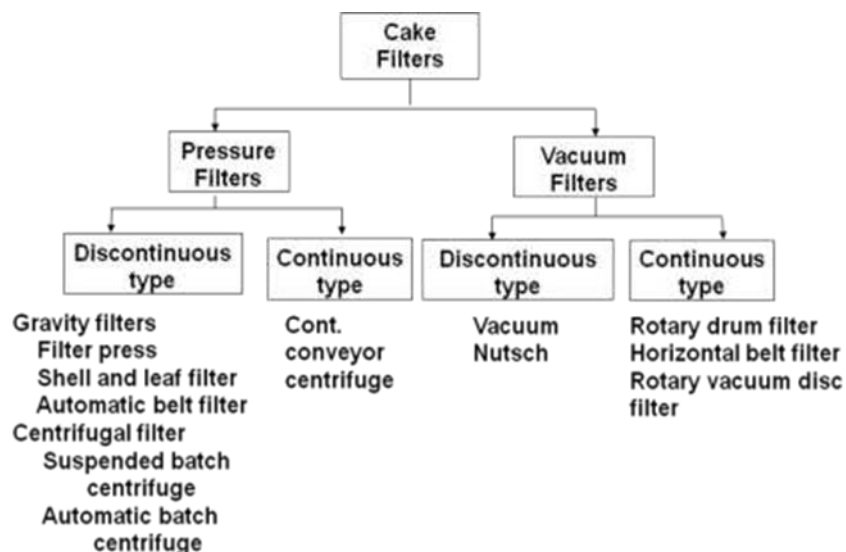

Fig. Classification of cake filters

The filters may be continuous or discontinuous types depending on whether the discharge of filtered solids is steady or intermittent. During much of the operating cycle of a discontinuous filter, the flow of fluids through the device is continuous, but it must be interrupted periodically to permit discharging the accumulated solids. In a continuous filter, the discharge of both solids and fluids is not interrupted as long as the equipment is in operation. Pressure filters are usually discontinuous; vacuum filters are usually continuous. Pressure filters can be either gravity filters or centrifugal filters depending on whether a pump or blower or centrifugal force is used to develop pressure on the upstream side. In vacuum filters the vacuum is maintained on the downstream side.

The clarifying filters remove small amounts of solids to produce a clean gas or sparkling clear liquid such as beverages. These are also known as deep bed filters, because the particles of solids are trapped inside the filter medium and usually no layer of solid can be seen on surface of the medium. The examples are cartridge filter and ultra-filter.

In case of cross flow filters, the feed suspension flows under pressure at a fairly high velocity across the filter medium. A thin layer of solids may form on the surface of the medium, but the high velocity keeps the layer from building up.

Plate and frame filter press

The characteristic features are as follows.

Construction and operation

- It consists of plates and frames arranged alternatively and supported on a pair of rails. The plates have ribbed surfaces and the hollow frames are separated from the plates by filter clothes, i.e. the set of plates are designed to provide a series of chambers in which solids are collected.
- The plates may be square or circular, vertical or horizontal, and may be 6 to 50 mm thick. Usually square plates are used and the size may be 0.15 m to 2 m on a side. In many cases, the compartments for solids are formed by recesses in the faces of molded polypropylene plates.
- The press is closed by means of a hand screw or a hydraulic press.
- The feed channel is formed by a hole in each plate and frame, these holes registering together. Slurry enters through this channel running length wise through one corner of the assembly.
- In each frame there is an opening from this channel that admits feed into the frame and at the bottom of each plate there is an outlet for the filtrate. Liquor passes through the cloth, down grooves or corrugations in each faces, and out of the press.
- During filtration, the solids quickly form a thick cake at low pressure (1.5-3.2 kg/cm² gauge pressure) on the cloth covered faces of the plates.
- The filtration is continued until the frames are completely filled, i.e. when the filtrate ceases to flow from the drain cock at the bottom. This is known as solid filling or the press is said to be jammed.

- Filling may be followed by blowing of air to expel solution before wash is applied. At that time no displacement of cake occurs as the cell is completely filled with solids.
- Then washing is carried out by admitting wash solution or water under pressure behind the filter cloth of each alternate plate.
- An air blow may be given again to remove the wash and obtain as dry cake as possible.
- The press is then opened, cake removed and dropped onto a conveyor or storage bin. Slurry is admitted to each compartment under pressure; liquor passes through the canvas and out a discharge pipe, leaving the wet cake of solids behind.

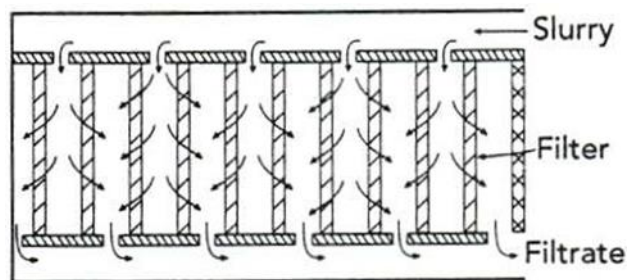

Fig. Flow pattern in a Plate and frame filter press

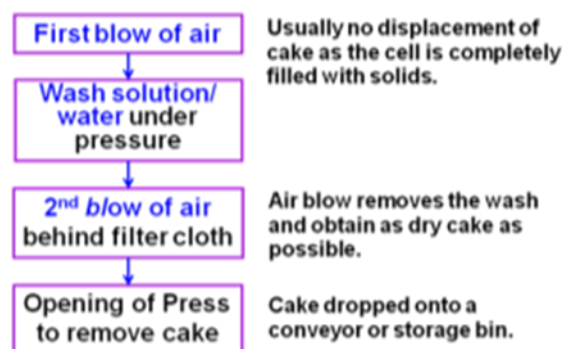

Fig. Removal of solid filling in a plate and frame filter press

Salient features

- It involves low capital cost, high flexibility for different types of products, and can be easily maintained.
- The dryness of the cake is one major advantage with the plate and frame press.
- The disadvantage associated with this system is the intermittent operation since the presses must be taken away and cleaned by hand at the end of each cycle.

Application: This is widely used for production of apple juice and cider, other juices, and filtration of oil.

Shell and leaf filter

Construction and operation

- It consists of a set of vertical mesh leaves held on a retractable tract.
- The leaves are coated in filter medium and supported on a hollow frame which forms the outlet channel for the filtrate.
- The leaves are stacked vertically or horizontally inside a pressure vessel.
- During operation, the leaves are inside the closed tank; feed enters through the side of the tank; feed liquor is pumped into the shell at a pressure of approx. 400×10^3 Pa. and filtrate passes through the leaves into a discharge manifold.
- The cake is blown or washed from the leaves after completion of the filtration operation.
- In some designs the set of leaves rotate at 1-2 rev/min to improve the uniformity of cake build up.

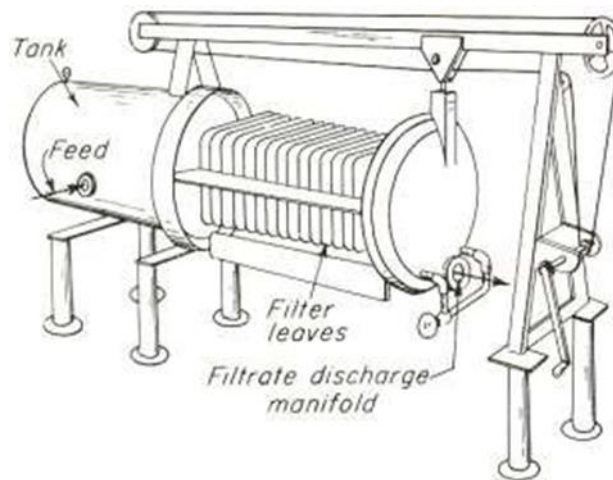

Fig. Shell and leaf filter

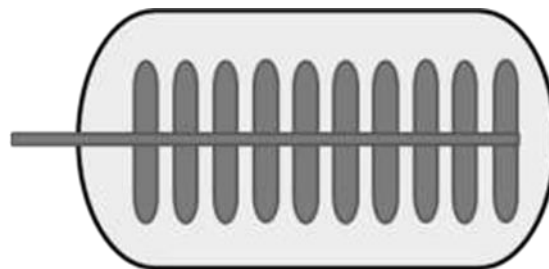

Fig. Leaves arranged in the shell

Salient features

- It involves higher cost than the plate filters.

Application

The shell and leaf filter is widely used for filtration involving the filter aids. Besides, the shell and leaf filter is used under following conditions:

- For filtration under higher pressures than are possible in a plate and frame filter.
- To economize on labor.

- When more effective washing of the cake is necessary.

Besides there are also other common types of filters as automatic belt filter, suspended batch centrifuges, automatic batch centrifuges, continuous filtering centrifuges, rotary drum filter, horizontal belt filter and clarifying filters, etc. which have been explained in the ‘Manual of Food Engineering Equipment’ by the same author.

Lecture 14

MEMBRANE SEPARATION

Membrane separation is a process of separating food components by using semi-permeable membranes, basing on the molecular size and molecular weight of the components. The driving force of the separation process is, for example, differences in concentration or pressure between the two sides of the membrane.

Membrane separation processes can remove much smaller substances, such as viruses and dissolved ions, from the water.

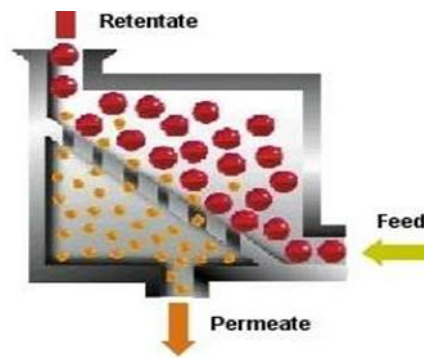

Fig. Principle of operation in membrane separation

MEMBRANE PROCESSING METHODS

The different membrane processing methods are as follows.

- ✓ Reverse osmosis (RO). Concentration of solution by removal of water
- ✓ Nanofiltration (NF). Concentration of organic components by removal of part of monovalent ions like sodium and chlorine (partial demineralization).
- ✓ Ultrafiltration (UF). Concentration of large and macro molecules
- Microfiltration (MF). Removal of bacteria, separation of macromolecules

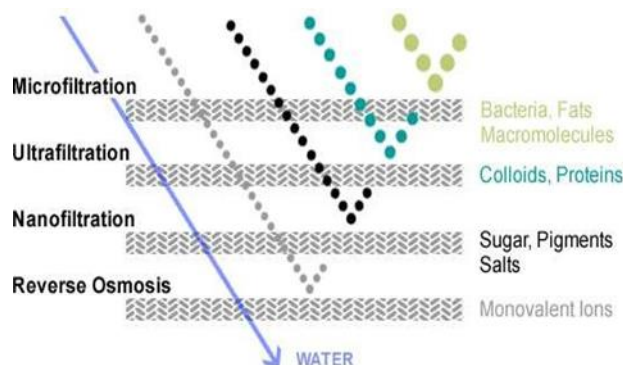

Fig. Application of different membrane processing technologies

There are also other methods for selective separation as follows.

- Pervaporation
- Ion exchange
- Electro-dialysis

REVERSE OSMOSIS

It is a membrane separation process, driven by a pressure gradient, in which the membrane separates the solvent (generally water) from other components of a solution. The solvent flow is opposite to the normal osmotic flow. The membrane pore size is very small allowing only small amounts of very low molecular weight solutes to pass through the membranes.

Applications

Broadly used to separate water from low molecular weight solutes (salts, aroma compounds etc.), which have high osmotic pressure.

- Concentrate and purify fruit juices, enzymes, fermentation liquors and vegetable oils; pre-concentrate juices and dairy products before evaporation.
- Concentrate wheat starch, citric acid, egg white, milk, coffee, syrup, natural extracts and flavors.
- To clarify wine and beer (De-alcoholization for low alcohol wines and beers)
- To determine and purify water from boreholes or rivers or desalination of sea water.
- Water and waste water purification.
- Concentration of whey during cheese manufacture.

NANOFILTRATION (NF)

- New class of pressure-driven membrane processes that lies between RO and UF
- Pressure range: 10-50 bar (lower pressure than RO)
- Rejects ions with more than one negative charge (such as SO_4^{2-} , CO_3^{2-})
- Also known as loose reverse osmosis

ULTRAFILTRATION

Ultra-filtration is similar to reverse osmosis with low pressure of operation. In UF, the membrane pore size is larger allowing some components to pass through the pores with the water. It is a separation/ fractionation process.

Dia-filtration is a specialized type of ultra-filtration process in which the retentate is diluted with water and re-ultra filtered, to reduce the concentration of soluble permeate components and increase further the concentration of retained components.

Applications of ultrafiltration

- Most commonly used to pre concentrate milk prior to preparation of other range of dairy products

- Concentration of sucrose and tomato paste.
- Separation and concentration of enzymes, other proteins or pectin.
- Treatment of water to remove bacteria and contaminants greater than 0.003 μ dia.
- To selectively remove lactose and salts from the whey.
- Removal of protein hazes from honey & syrups.
- Pretreatment for RO to prevent fouling by organic and colloidal material

MICROFILTRATION

- Microfiltration (MF) designates a membrane separation process similar to UF but with even larger membrane pore size allowing particles in the range of 0.2 to 2 micrometers to pass through.
- The pressure used is generally lower than that of UF process.
- MF is used in the dairy industry for making low-heat sterile milk

Membrane techniques

- Counter diffusion
- Osmotic distillation
- Electro dialysis
- Ion-exchange

Counter diffusion

- Separate small ions from large molecules.
- Hollow fiber cellulose diffusion tubes.
- Counter diffusion can produce 50 per cent demineralization.
- which may represent 70 per cent removal of monovalents.

Osmotic distillation

- Low pressure and low temperature separation
- Hollow fiber or spiral wound hydrophobic membrane

Electro dialysis

- Similar to Ion exchange separation.
- Used to separate electrolytes from non-electrolytes and to exchange ions between solutions.
- Direct current is passed through a solution having number of ion exchange plates/membranes.
- The ion selective membranes act as barriers to either cations or anions.

- Anions and cations are attracted towards anodes and cathodes, respectively.
- The membranes are arranged alternatively to form ion diluting cells and ion concentrating cells.
- Electro dialysis is used for demineralization of milk products.
- It is also used for desalination of water.
- Also used to de-mineralize whey, to remove potassium and tartaric acid from wines and to de acidify fruit juices.

Ion- exchange

- Food components are separated basing on their electrical properties.
- Metal ions, proteins, amino acids and sugar are transferred from the feed and retained on a solid ion exchange material.
- Two types of ion exchangers (having fixed electrical charges) namely cation exchanger that attracts cations and anion exchanger that attracts anions by a process called electro static adsorption.
- The components are then separated by washing off the ion exchangers.
- They are constructed using porous matrix made of polyacrylamides, polystyrenes, dextrans or silica.
- Generally employed for de-colorization of sugar syrup, protein recovery from whey, softening & demineralization of water and separation of enzymes.

Lecture 15

CHEESE MANUFACTURE

- ✓ Cheese has been defined as a product made from the curd obtained from milk by coagulating the casein.
- ✓ With the help of rennet or similar enzymes in the presence of lactic acid produced by adding microorganisms,
- ✓ From which part of the moisture has been removed by cutting and/or pressing which has been shaped in a mould, and then ripened by holding it at some time at suitable temperature and humidity.
- ✓ Cheese consists of a concentration of the constituents of milk, principally fat, casein and insoluble salts, together with water in which small amounts soluble salts, lactose and albumin are found.
- ✓ To retain these constituents in concentrated form, milk is coagulated either by means of lactic acid produced by bacteria or by the addition of rennet or by both.
- ✓ A portion of water is removed by cutting, cooking, stirring or draining the curd or by mechanical application of pressure.

METHOD OF MANUFACTURE:

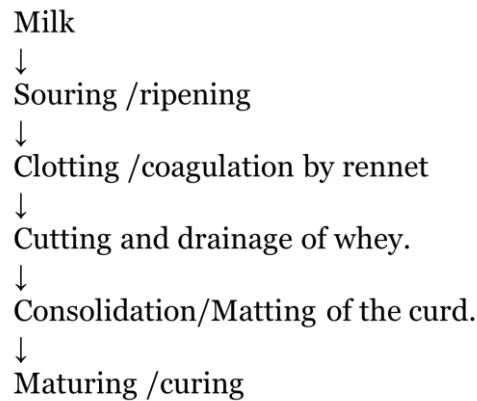

Factors affecting cheese manufacturing:

1. Type of milk used
2. Degree of souring and type of souring organisms added
3. Temperature of renneting and subsequent cooking or scalding of the curd in the whey
4. Milling and salting of the curd before putting in the hoop or mould
5. Pressure applied to the green cheese
6. Time, temperature and relative humidity of ripening

7. Special treatments such as stabbing the cheese, bathing in the brine and surface treatment to produce a certain type of coat.

Food and nutritive value of cheese:

- ✓ Cheese has high nutritive value
- ✓ It is an excellent source of milk proteins.
- ✓ a rich source of calcium and phosphorus
- ✓ and excellent source of several fat soluble vitamins, such as A, D, E &K;
- ✓ A concentrated source of energy. Cheddar cheese has about 400 calories /100 g.
- ✓ Palatable and digestible; there is practically no waste

Manufacture of cheddar cheese:

- ✓ Receiving of milk
- ✓ Preheating
- ✓ Filtration/clarification.
- ✓ Standardization
- ✓ Pasteurization (63°C/30min.)
- ✓ Adding starter cultures (ripening)
- ✓ Adding colour
- ✓ Adding rennet(clotting)31°C.
- ✓ Coagulation and setting
- ✓ Cutting
- ✓ Cooking (up to 37°C)
- ✓ Drainage of whey
- ✓ Cheddaring
- ✓ Milling
- ✓ Salting

- ✓ Hooping
- ✓ Dressing
- ✓ Pressing
- ✓ Drying
- ✓ Paraffining
- ✓ Curing/ maturing.

Receiving milk:

- ✓ Only high-grade milk can yield high grade cheese. The quality of finished cheese depends upon the initial quality of milk from which it is made.
- ✓ Successful cheese factories follow a system of daily, efficient grading of all milk received. This consist of
 - ✓ Determining the odour of milk.
 - ✓ Inspecting the appearance of milk ,
 - ✓ Determining the sediment
 - ✓ Determining the percentage of titrable acidity.
 - ✓ Examining milk for bacteriophage, antibiotics, and inhibitory substances.
 - ✓ After the milk has been examined for quality and accepted, it is weighed, then a representative sample is taken for determining of fat and casein contents etc.

Filtration and clarification:

- To remove visible dirt in milk . The milk is usually preheated to 35 to 40°C for efficient filtration and clarification.

Standardization:

In cheese making standardization refers to adjustment of the casein/fat ratio in cheese to 0.68 to 0.70. The objectives are

- To regulate the fat in the dry matter of cheese.
- To produce the maximum amount of cheese per kg.of fat in cheese milk.

Pasteurization:

The usual temperature time employed for pasteurization of cheese milk is holder – 63°C for 30min. HTST – 72°C for 15 sec.

The objectives or advantages of pasteurization of cheese milk are

- To destroy all pathogens
- To destroy fault producing microorganism.
- To produce a more uniform product of highquality.
- To increase the yield.

Addition of calcium chloride:

- Excessive heat treatment of milk causes the precipitation of a part of calcium salts in milk, this results in slower renneting action and a weaker curd, which can be corrected by the addition of 0.001 to 0.03 per cent calcium chloride to milk.

Adding starter:

- Ripening or souring of milk refers to the development of acidity in milk from the time it is received in the vat until renneting. In cheese milk, ripening is done by the addition of starter.
- Ripening in milk is measured by titration, rennet test and pH meter.

Adding colour:

- The colour of cheese is usually an alkaline solution of annatto. The colour is usually diluted with approximately 20 times its volume of potable water for even distribution. The usual amount of colour is 30 to 200 ml or more for 1000 kg of milk.

Renneting:

- Adding rennet to milk in cheese making is commonly known as renneting or setting.
- Rennet is available as liquid or powder or as tablet. Commercial rennet should be stored in a closed vessel, in a dark room at below 10°C.
- Rennet: it is a sulphur containing protein. One part can clot about 5 million parts of milk. In cheese making one part of liquid rennet (2%) is used for about 5000 parts of milk. It is very sensitive to alkali. Heating to 70°C at pH 6.8 – 7.0 will destroy it in 14 minutes.

Coagulation:

- This refers to liquid milk changing to a semi-solid junket. The first signs of coagulation are that bubbles of air stirred into the milk surface take longer to break and a spatula dipped into the milk and withdrawn shows small flakes of curd.

Cutting:

- This refers to cutting of the 'firm' coagulum into cubes of a specific size.

Method of cutting

- The curd is usually first cut with the horizontal knife lengthwise, then with the vertical knife lengthwise and width wise.

Cooking:

- This refers to the heating of curd cubes; it begins within 15 minutes of cutting.

Drainage of whey:

- This refers to the removal of whey from the curd. When the cubes have been reduced to about one-half of their size at cutting, the acidity approaches a desirable limit and the cubes attain a desirable consistency (elastic feel when squeezed), stirring is stopped and the cubes 'pitched'. (Pitching refers to the curd cubes dropped to the bottom of the vat and piling them up together). The curd cubes are pushed away from the gate of the vat, a strainer is inserted in the gate, a curd-pail is hung on the curd out let, and the whey is drawn from the vat.

Cheddaring:

- Packing: After the bulk drainage of whey, the curd cubes are kept closely together in two heaps with a channel in between. This is known as packing and takes 5 to 15 minutes after

dipping. It results in the formation of two long slabs of curd. These are cut with a cheese knife into blocks or strips 15 to 20 cm wide

- Turning: As soon as the blocks (strips) of curd can be handled without breaking, they are rolled bottom-side in the vat. This is called turning and is carried out every 15 minutes till the curd is ready for milling and salting.

Milling:

This refers to the mechanical operation of cutting the blocks of cheddar curd into small pieces with the help of a cheese mill, with the following objectives:

- To promote the further removal of whey
- To enable quick distribution of salt in the curd
- To prepare curd for pressing into final form
- And also for de-odourization, cooling of the curd etc.

Salting: This refers to the addition of common salt to the curd pieces. Salt in cheese affects flavour, body and texture, and keeping quality. Cheese without salt is often soft, ripens quickly and rapidly develop unpleasant flavors.

Hooping:

- This refers to the curd being placed in hoops or moulds in which the cheeses curd is pressed into its final shape. For hooping operation all the added salt should have completely dissolved and the temperature at hooping should be 30-32° C. Hooping and pressing at too high a temperature causes an excessive loss of fat, decreased yield, development of abnormal flavours and exaggeration of bacterial defects. On the other hand, hooping and pressing at a too a low temperature result in an open texture, imperfect rind formation and lack of whey drainage.

Dressing:

- Refers to arrangement of the cheesecloth before and after pressing.

Pressing:

- This refers to the operation of forcing the particles of milled and salted curd in the hoops into the smallest possible space to give cheese its final shapes. Cheese pressing is done with the help of presses which may be, Screw or Pneumatic or Hydraulic or spring types.

Drying:

- This is done for rind formation in cheese. It involves first taking the cheese out of the hoop and then stamping of date, batch, variety name etc., and keeping in a drying room at 12 to 16 ° C for a few days. The cheese is turned at 24-hour intervals so that both ends and sides of the cheese can dry and form the desired rind.

Paraffining:

- This refers to the operation of dipping the cheese for a few seconds in a bath of melted paraffin, whereby a thin coating of the paraffin is applied to the surface of the cheese.

Curing:

•The curing/ripening/souring/maturing of cheese refers to the storage of cheese for at least 2 to 3 months at a given low temperature (0-16°C) during which its physical, chemical and bacteriological properties are profoundly changed, resulting in the development of a characteristic flavour, body and texture.

Lecture 16

PANEER MANUFACTURE

Paneer is a heat-acid coagulated milk product obtained by coagulating standardized milk with the permitted acids at specified temperature. The resultant coagulum is filtered and pressed to get the sliceable curd mass. Paneer has a firm, close, cohesive and spongy body and smooth texture. It is mainly prepared from buffalo milk and used for large number of culinary dishes. Though originally it was localized in Northern part of India but now it is preferred almost all parts of the country. Paneer is generally sold as blocks or slices, it is also referred as Indian fresh cheese. It is reported that about 5% of the milk produced in India is converted into paneer and paneer production is growing annually at the rate of 13%.

Chemistry of Milk Coagulation During Paneer Production

The phenomenon of coagulation involves formation of large structural aggregates and network of protein in which milk fat globules gets embedded. Acid and heat treatment causes the physical and chemical changes in casein. Heating causes interaction of β -lactoglobulin with κ -casein and the complex formed between β -lactoglobulin and α -lactalbumin. Acidification initiates the progressive removal of tri-calcium phosphate from the surface of the casein and it gets converted into mono-calcium phosphate. Further calcium is progressively removed from calcium hydrogen caseinate to form soluble calcium salt and casein. Colloidal dispersion of discrete casein micelles changes into large structural aggregates of casein. Under such a circumstance dispersion is no longer stable, casein gets precipitated and forms coagulum. Fat is embedded in the casein network.

Method of Manufacture

Traditional method of manufacture

Buffalo milk is boiled in a bigger iron vessel and a small portion of this is transferred to a smaller vessel. The coagulant (usually sour whey) is added to hot milk and stirred with a ladle till coagulation is completed. The contents of the vessel are emptied over a piece of coarse cloth to drain off whey. The whole process is repeated till all the milk is coagulated. The curd is collected after draining the whey and pressed to remove more whey. Finally, product is then dipped in chilled water.

Industrial method for paneer making:

Buffalo milk is standardized to 4.5% fat and 8.5% SNF (standardize the buffalo milk to a fat: SNF ratio of 1:1.65). Milk is heated to 90°C without holding (or 82°C with 5 min holding) in a jacketed vat and cooled down to 70°C. Coagulation is done at about 70°C by slowly adding 1% citric acid solution(70°C) with constant stirring till a clean whey is separated at (pH 5.30 to 5.35) and coagulum is allowed to settle for 5 min and drained off the whey. The curd so obtained is filled into hoops lined with muslin or cheese cloth. Pressure is applied on top of the hoop at a rate of 0.5 to 1kg/cm². The pressed blocks of paneer are removed from the hoops and immersed in pasteurized chilled water for 2-3 hr.

The chilled paneer is then removed from water to drain out. Finally paneer blocks are wrapped in parchment paper / polyethylene bags and placed in cold room at about 5 to 10°C.

Paneer from cow milk

Cow milk yields an inferior product in terms of body and texture. It is criticized to be too soft, weak and fragile and unsuitable for frying and cooking. Buffalo milk contains considerably higher level of casein and minerals particularly calcium and phosphorous, which tends to produce hard and rubbery body while cow milk produces soft and mellow characteristics. By replacing one third of buffalo milk with cow milk, a good quality paneer can be made. Buffalo milk paneer retains higher fat, protein and ash content and lactose as compared to cow milk paneer. To make paneer exclusively from cow milk, certain modifications in the conventional procedure have to be made. Addition of calcium chloride at the rate of 0.08 to 0.1% to milk helps in getting a compact, sliceable, firm and cohesive body and closely knit texture. A higher temperature of coagulation (85°-90°C) with coagulation of milk at pH 5.20 to 5.25 helps in producing good quality paneer from cow milk. However, at this pH of coagulation, moisture, yield and solids recovery are less.

Lecture 17

BUTTER MANUFACTURE

Before, we start discussing about butter manufacture; let us have a understanding of some related milk products/ by products which often confuse us.

Butter. It is essentially the fat of milk. It is usually made from sweet cream and is salted. Salt- less (sweet) butters are also available.

Butter can also be made from acidulated or bacteriologically soured cream. (Now a day, bacterial acidifying and heat treatment are more common.)

Milk fat. This is the lipid component of milk and milk-derived products. It is mostly comprised of triglycerides.

Butterfat. It is almost synonymous with milk fat; all fat components in milk that are separable by churning.

Anhydrous milk fat (AMF). This is the commercially prepared extraction of cow's milk fat, found in bulk or concentrated form (comprises of 100% fat, but not necessarily all of the lipid components of milk).

Butter oil. Synonymous with anhydrous milk fat.

A more accepted definition of butter is as follows.

Butter is essentially a water-in-oil emulsion, comprising of more than 80% milk fat, but also containing water in the form of tiny droplets, perhaps some milk SNF, with or without salt (sweet butter).

An emulsion usually has two phases, viz. the continuous phase, the dispersed phase and there is also a supporting emulsifier. Milk is an emulsion of oil in water, whereas butter is an emulsion of water in oil.

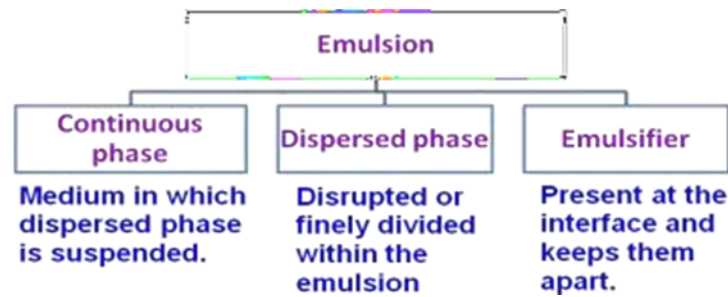

Fig. Different phases (constituents) of an emulsion.

Main Constituent	Normal salted butter	Indian butter
Fat	80 – 82 %	80.2%
Water	15.6 - 17.6%	16.3%
Salt	about 1.2%	2.5%
Protein, Ca, P	about 1.2%	1.0%

In addition, butter also contains fat-soluble vitamins A, D and E.

- As per PFA rules (1976), table /creamy butter should contain not less than 80% fat, not more than 1.5% curd and not more than 3% common salt.
- Butter should have a uniform color, be dense and taste clean.
- The water content should be dispersed in fine droplets so that the butter looks dry.
- The consistency should be smooth so that the butter is easy to spread and melts readily on the tongue.

BUTTER MAKING PROCESS

- Even in the 19th century, butter was still made from cream that had been allowed to stand and sour naturally.
- The cream was then skimmed from the top of the milk and poured into a wooden tub.
- Butter making was done by hand in butter churns.
- The natural souring process is, however, a very sensitive one and infection by foreign micro-organisms often spoiled the result.
- The commercial cream separator was introduced at the end of the 19th century, the continuous churn was commercialized by the middle of the 20th century.

Pasteurization

- It is usually done at 82-88°C or more.
- The skim milk from the separator is pasteurized and cooled before being pumped to storage. It is usually concentrated and dried.

Ripening

- Ripening is the fermentation of cream with the help of desirable starter culture.
- Mixed cultures of *Streptococci cremoris*, *Str. Lactis*, *Str. diacetyl lactis*, *Leuconostoc citrovorum*, *Leuc. destranicum*, are used.
- The cream is ripened in 2 stages; 1st stage at 21°C to pH 5.5 and then 2nd stage at 13°C to pH 4.6.

Ageing and crystallizing

- In the ageing tank, the cream is subjected to a program of controlled cooling that helps to give the fat the required crystalline structure. (The program is chosen to accord with factors such as the composition of the butterfat.)
- The optimum temperature for Indian condition is usually 5-10°C.
- The time requirement is 12 - 15 h (at least 2-4 h).
- 0.2 % citric acid or sodium citrate may be added for flavor.

Churning

- Churning of cream consists of agitation at a suitable temperature until the fat globules adhere forming larger and larger masses, and until a relatively complete separation of fat and serum occurs.
- In the churning process, the cream is violently agitated for 5-10 min to break down the fat globules, causing the fat to coagulate into butter grains, while the fat content of the remaining liquid (buttermilk) decreases.

The butter churns are available in different configurations as shown in the following Figs

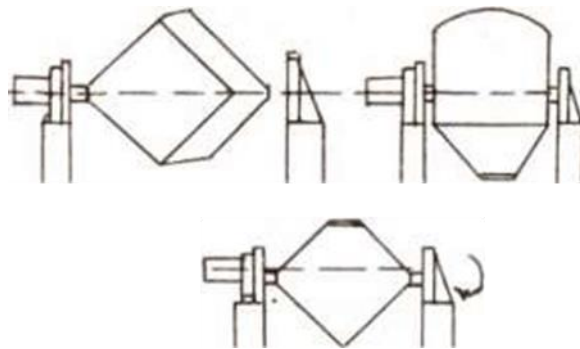

Fig. Different configurations of butter churns

- High cooling and ageing temperature requires less churning period, yield large fat losses in butter milk. Butter gets a soft greasy texture.
- Improper cooling and ageing of the cream does not allow the fat to be sufficiently solid, and the fat loss in buttermilk will be excessive, and the butter obtained will have an unsatisfactory, weak body.
- Low cooling and ageing temperature prolongs the churning period, decrease fat losses, produce a firm body, that has a satisfactory standing up capacity.

- Cooling to abnormally low temperatures, and ageing near that temperature causes the fat globules to become so firm that they bond together during churning only with difficulty, thus, the churning process is prolonged. Butter becomes too brittle.

Working and salting

The working of the butter is done for the following reasons.

- Working helps to obtain a homogenous blend of butter granules, water and salt.
- Forms a continuous fat phase containing a finely dispersed water phase. (During working, fat changes from globular to free fat. Water droplets decrease in size and should not be visible in properly worked butter.)
- Influences the characteristics by which the product is judged such as aroma, taste, keeping quality, appearance and color.
- Salt is used to improve the flavor and the shelf-life.
- Normally worked butter has 0.5-10 ml air per 100 g butter. Air content is important as it affects density of butter, microbial spoilage and oxidative spoilage.
 - Overworked butter will be too brittle or greasy depending on whether the fat is hard or soft. Some water may be added to standardize the moisture content. Precise control of composition is essential for maximum yield.

Packaging

It is the unit operation to protect the butter during transit and storage.

CONTINUOUS FLOTATION CHURN

- The cream is first fed into a churning cylinder fitted with beaters that are driven by a variable speed motor.
- Rapid conversion takes place in the cylinder, and when finished, the butter grains and butter milk pass on to a draining section.
- The first washing of the butter grains takes place en route- either with water or recirculated chilled buttermilk.
- The working of the butter commences in the draining section by means of a screw, which also conveys it to the next stage.
- On leaving the working section, the butter passes through a conical channel so that any remaining buttermilk is removed.
- Immediately afterwards, the butter may be given second washing, this time by two rows of adjustable high-pressure nozzles.

Churn overrun. It represents the extra yield of materials obtained in butter after churning.

Lecture 18

ICE CREAM MANUFACTURE

Ice cream may be defined as a frozen dairy product made by suitable blending and processing of cream and other dairy products together with sugar and flavour, with or without stabilizers or colour, and with the incorporation of air during the freezing process.

According to the PFA rules (1976) ice cream is the frozen product obtained from the cow or buffalo milk or a combination thereof or from cream and or on the milk products, with or without the addition of cane sugar, eggs, fruits, fruit juices, preserved fruits, nuts, chocolate, edible flavours and permitted colours. It may contain permitted stabilizers and emulsifiers not exceeding 0.5 per cent by weight. The mixture must be suitably heated before freezing. The product should contain not less than 10% milk fat, 3.5% protein, and 36% total solids. However, when any of the aforesaid preparations contains fruits or nuts or both, the content of milk fat may be proportionately reduced but not less than 8 % by weight, starch may be added to a maximum extent of 5 %, with a declaration to that effect on the label.

Classification:

Plain: Ice cream in which the colour and flavouring ingredients together amounts to less than 5 per cent of the volume of the unfrozen ice cream. Example: vanilla and coffee ice creams.

Chocolate: Ice cream flavoured with cocoa or chocolate.

Fruit: Ice cream containing fruits with or without additional fruit flavouring or colour. Fruits such as strawberry, apricot, pineapple, mango, banana, etc., may be fresh, frozen, frozen packed, canned or preserved.

Nut: Ice-cream containing nuts, such as almonds, pistachio, walnuts, cashew nut, etc., with or without additional flavoring or color.

Milk ices or lollies: According to the PFA rules (1976) these refers to the frozen product obtained from the milk or skim milk or milk products with or without the addition of cane sugar, eggs, fruits, nuts, chocolate, edible flavours, and permitted food colours. It may contain permitted stabilizers not exceeding 0.5 % of the product. The mixture should be suitably heat treated before freezing. The product should contain not more than 2.0% milk fat, less than 3.5% proteins and not less than 20.0% total solids.

Ices: Made of fruit juices sugar and stabilizers with or without additional fruit acid, colour, flavouring, or water, and frozen to the consistency of ice cream. Usually contain 28 to 30 per cent sugar, 20 – 25per cent over run and no dairy products.

Sherbet: made of juices, sugar, stabilizers and milk products. It is similar to an ice except that milk, either whole, skim, condensed or powdered, or ice cream mix, are used in place of all or, part of the water in an ice.

Fancy moulded: Moulded in fancy shapes and composed either of one colour and flavour of ice cream or a combination of colours and flavours, or especially decorated. Examples: are brick ice cream, cakes, cake roll, moulds representing fruits, etc.

Novelties: Novelty ice cream or frozen is an especially shaped and usually low priced package containing an individual serving whose main appeal consists in its shape, size, colour or convenience for eating.

Soft ice cream: Sold as drawn from the freezer without hardening.

Composition:

The composition of ice cream is usually expressed as a percentage of its constituents, i.e. a percentage of milk fat, milk solids not fat, sugar, stabilizers, total solids etc. Its composition varies in different localities and in different markets.

S.NO.	Characteristics	Requirements
1.	weight (g./litre/min.	525
2	Total solids(%wt .min)	36.0
3.	Milk fat (% wt. Min.)	10.0 (Tentative)
4.	Acidity (% lactic acid max.)	0.25
5.	Sucrose (%wt. Max.)	15.0
6.	stabilizers/emulsifiers(%wt. Max)	0.5
7.	Standard plate counts (per g.)	Not more than 2,50,000
8.	Coliform count (per g.)	Not more than 90
9.	phosphatase test.	Negative.

Food and nutritive value:

- ✓ Ice cream contains two to three times as much fat and slightly more protein than does milk. In addition it may contain other food products such as fruits, nuts, eggs, and sugar which enhance its food value. However, likemilk, it lacks iron, vitamin C, and some of the trace minerals.
- ✓ Ice cream is a rich source of calcium, phosphorus and other minerals of vital importance in building good bones and teeth.
- ✓ Being rich in lactose, ice cream favours greater assimilation of the calcium content on the diet.
- ✓ The protein content of ice cream rates high both in quantity and quality. The milk and egg proteins are complete, that is, they contain all the amino acids essential to animal life and are especially important sources of tryptophan and lysine which are lacking in many plant proteins. Ice cream provides these valuable proteins in a very palatable form. In fact, ice cream is the most palatable source of milk proteins to vegetarians.
- ✓ Ice cream is an excellent source of food energy. Having twice to three times the fat content of milk. And more than half of its total solids being sugar the energy value of ice cream is very high. It is therefore, a very desirable food item for growing children and persons who need to put on weight.
- ✓ Ice cream, is a rich source of essential vitamins, without which normal health and growth cannot be maintained. Thus it is an excellent source of vitamin A, a good source of vitamin B and G (riboflavin) and a fairly good source of Niacin, vitamin E, and in fruitice cream, of vitamin C. The digestibility and palatability of ice cream is also very high.

Properties of mix:

Viscosity: This is defined as the resistance offered by liquids to flow. Viscosity is considered an important property of the ice cream mix, and a certain amount of it seems essential for proper whipping and the retention of air. Two types of viscosity exists in ice cream mixes:

Apparent viscosity: This is a thickened condition that disappears with agitation, and Basic viscosity: which remains after the apparent viscosity disappears. The viscosity of ice cream mix is influenced by composition, kind and quality of ingredients, processing and handling of the mix, total solids concentration and temperature.

Acidity and pH

The normal acidity of ice cream mixes is dependent upon the serum solids content, and is calculated by the formula:

$$(\% \text{ serum solids in mix} / \% \text{ serum solids in milk}) \times \% \text{ Acidity of mix} = \% \text{ Acidity of milk}$$

The normal acidity of ice cream mix is 0.15%. The pH of ice cream mix should be 6.3. If the mix acidity is more, it may be neutralized with suitable neutralizers Eg. Sodium bicarbonate. It should be remembered that good ice cream couldn't be made from a highly acidic cream.

Mix stability

This refers to stability or resistance to separation by the milk proteins in an ice cream mix. Instability results in separation of milk proteins as coagulated or precipitated material in the mix, and the resulting ice cream has a curdled appearance on melting. Mix stability is affected by high mix acidity, low citrate and phosphate content, high calcium and magnesium content, high homogenizing pressure, high heat treatment, low ageing time, destabilizing effect of freezing etc.

Surface tension

This refers to the force of attraction between the molecules of a liquid at its surface. The greater the attraction between the molecules, the higher the surface tension and vice versa. The unit of measurement of surface tension is dyne.

The surface tension can be readily decreased by the addition of emulsifiers. Mixes with lower surface tension values will have excessive whipping rate, fluffy short body characteristics and susceptibility to the shrinkage defect. The normal surface tension value of ice cream mix may range from 48- 53 dynes/sq.cm.

Freezing point

The freezing point of ice cream is dependent on the soluble constituents and varies with its composition. The mix constituents, which affect the freezing point directly, are sugar, milk sugar, milk salts, and any other substances that may have been added and are in true solution. Freezing point is indirectly affected by fat, protein and any other constituents not in true solution by replacing water. Glucose, sucrose and corn sugar depress the freezing point in the descending order. In fruit ice-cream the freezing point will depend on the type of sugar used in fruit preparations.

An average mix has a freezing point of 27.5°F. mixes with high sugar and milk solids not fat content s may range to 26.5°F, while high fat, low MSNF or low sugar content mixes may range to 29.5°F.

Whipping rate:

A high whipping rate means the ability to whip rapidly to a high over run. The present hypothesis is that whipping ability is based on the tensile strength and the strength of the

lamella (i.e. walls around the air cells). Whipping ability is improved by a high processing temperature, proper homogenization and ageing the mix for 2-4hours.

Smaller fat globules and less clumping of fat globules increase the whipping ability. Mixes made from butter, butter oil, or frozen cream have poor whipping ability. Egg yolk solids, fresh cream, buttermilk solids improve whipping ability. Sugar decrease the whipping ability except when added after homogenization, in which case it increases it.

The construction and operation of freezer affect the whipping ability.

The rate of whipping is measured by calculation the over run at one minute intervals while the mix is being frozen in a batch freezer, normally within 3 to 5 minutes after the freezing process starts, the mix is frozen and within 7 minutes an overrun of 90 percent is obtained. In mixes, which have a rapid whipping rate, 90 per cent overrun may be reached in 5 minutes or less. Mixes requiring 8 minutes or more to reach 90 per cent overrun are considered to have slow whipping rate.

Lecture 19

PACKAGING OF MILK AND MILK PRODUCTS

Main factors causing deterioration during storage:

- ✓ Mechanical forces (impact, vibration, compression or abrasion)
- ✓ Climatic influences causing physical/chemical changes (UV light, moisture vapour, oxygen, temp. changes, etc.)
- ✓ Contamination by microorganisms, insects, soil
- ✓ Pilferage, tampering, adulteration

Use of packaging

Contain : Protect : Communicate : Market

- Extend shelf life
- Safe and efficient transportation
- Reduce product waste due to contamination
- Provide customers with information (sometimes a legal requirement)
- Entice the customer to purchase

Basic requirements of packaging material:

The Package

- ✓ should not contaminate product.
- ✓ should allow efficient and economical operation on production line.
- ✓ should be resistant to breakage.
- ✓ should be cost effective.
- ✓ should be aesthetically pleasing.
- ✓ should have a functional size and shape.
- ✓ should retain the food in convenient form.
- ✓ should be suitable for easy disposal or reuse



Two main groups of packaging materials:

Shipping containers, which contain and protect the contents during transportation and distribution (e.g. wooden, metal or fibre-board cases, crates, barrels, drums and sacks)

Retail containers (or consumer units) which protect and advertise the food in convenient quantities for retail sale and home storage (e.g. metal cans, glass bottles, jars, paperboard cartons, flexible plastic bags, sachets and overwraps).

Types of packaging for milk products:

Product	Type of packaging
Milk and milk products	<ul style="list-style-type: none"> ✓ PE pouches ✓ LDPE and PVC bottles ✓ Bottles made from LDPE can be used at temperature of up to 120°C and bottles made from polycarbonate up to 150°C. ✓ Glass bottles ✓ Board laminated with aluminum foil and coated with PE on the inside (for aseptic processing)
Cultured milk products	<ul style="list-style-type: none"> ✓ Glass bottles ✓ Cartons ✓ Unplasticised PVC or PS (coloured to give light protection)
Unripened soft cheese	<ul style="list-style-type: none"> ✓ Deep drawn containers made of hard PVC or impact resistant PS with welded or sealed closures of the same materials or sealed with coated aluminium foil. ✓ Grease proof paper or aluminium foil laminated to paper is suitable for soft cheeses which are expected to develop slimy surfaces. ✓ Aluminum foil prevents cheese from drying. ✓ Laminated films of polyester, aluminum and polythene are also used.
Cheese made from cultured milk	<ul style="list-style-type: none"> ✓ Weather proof cellulose ✓ Polypropylene films
Processed cheese	<ul style="list-style-type: none"> ✓ Hot filled into aluminum cups which are coated with a protective lacquer.

	<ul style="list-style-type: none"> ✓ It may also be wrapped in heat sealed lacquered aluminum foil.
Butter	<ul style="list-style-type: none"> ✓ Laminated al. foil (9 μm) and genuine parchment (50 g/cm²). ✓ Paper improved by plastics (PE, PVDC) and waxes (paraffin 10 g/m²) is also used, but does not give sufficient light protection. ✓ Laminate of aluminum and polythene
Evaporated milk	<ul style="list-style-type: none"> ✓ Cans made of electrolytically tinned mild steel which are closed either by soldering or by a seamed-on-lid. ✓ The thickness of the tinned steel is between 0.15 and 0.25 mm, depending on the size of the can. ✓ The tin layer deposited electrolytically can weigh 15 g/m² and this represents a layer thickness of between 1 and 2 μm. ✓ Glass bottles with crown cork closures are also used.
Dried milk	<ul style="list-style-type: none"> ✓ Cartons lined with aluminium foil on the inside and outside ✓ Aluminum PE foil bags ✓ Plastic coated paper bags ✓ Tin can with or without an inner bag ✓ For long storage times, a membrane of aluminum foil is used in addition to the snap-on lid to provide an additional seal.
Dried milk	<ul style="list-style-type: none"> ✓ Fat containing milk powders are often packed in an atmosphere of inert gases (e.g. 80% N₂ and 20% CO₂). The residual oxygen content should be less than 3%.
Bulk packing	<ul style="list-style-type: none"> ✓ Sacks made of kraft paper, laminated with various materials such as parchment, polythene, aluminum, cellulose, bitumen, wax or paraffin.
Ice-cream	<ul style="list-style-type: none"> ✓ Most bulk ice cream is packaged in a linerless bleached sulphite board carton, coated with wax or polyethylene-wax blends for protection from moisture and oxygen. ✓ Plastic containers made of PE are also used.

Lecture 20
FILLING OF MILK AND MILK PRODUCTS

Most food consumed is far removed in time and space from the point of its production. Packaging is a necessary aid for the storage and distribution of food. Food is packaged for four primary reasons: (a) to protect the product from contamination, by micro-organisms, macro-organisms and filth; (b) to retard or to prevent either losses or gain of moisture; (c) to shield the product from oxygen and light and (d) to facilitate handling. The package may also serve as a processing aid. It is a convenient item for the consumer and is a marketing tool. The sales appeal and product identification aspects of packaging are particularly important to the sales and marketing branches of food companies. Certain packages have obvious economic benefits, such as prevention of spills, ease of transporting, prevention of contamination, reduction of labour cost and so on. The quality of products as they reach the consumer depends on the condition of the raw material, on method and severity of processing and on conditions of storage. The chemical, physical and biological mechanisms of food deterioration are sensitive to various environmental factors and the most pertinent barrier property of the package varies with each product.

Filling of liquids and pastes

Filling by gravity flow

- ✓ Mostly used for glass bottles (not distorted)
- ✓ The filling process is up to a pre-set filling height.

Filling by metering

- ✓ Also known as volumetric filling as definite volumes are filled.
- ✓ The shape and the distortion of the package does not matter since the amounts to be filled are fixed before filling.

Filling by gravity flow:

Construction:

- ✓ Circular filler bowl under vacuum.
- ✓ Filler valves are mounted in the bottom of the bowl with vacuum pipes rising above the level of the milk.
- ✓ Empty bottles are lifted by a pedestal so that the rim of the neck of the bottle is pressed against filler valve rubber.
- ✓ Further lifting of the spring loaded filler valve rubber results in the formation of an annular orifice in the valve □ the liquid enters the bottle through it.

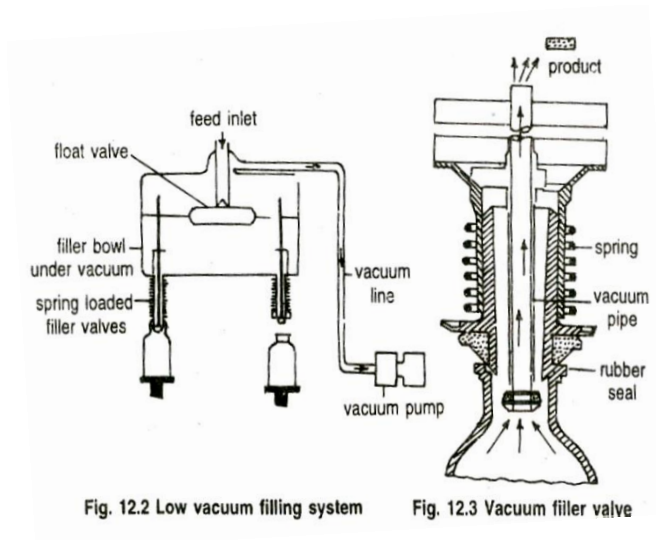

Operation

- ✓ As the bottle rises towards the valve, it is connected to vacuum. The air and foam are allowed to pass up and out through the hollow central vacuum tube.
- ✓ The valve rubber is then lifted compressing the spring → Milk flows down the annular passage into the bottle.
- ✓ As the bottle drops away from the valve. the milk line is sealed as the spring returns the rubber seal.

Advantages

- ✓ The filler valves do not open unless a bottle is in proper position.
- ✓ The filler valves do not fill broken or cracked bottles because milk will only flow if the vacuum in the bottle is built up.
- ✓ The use of the vacuum speeds the rate of filling and also prevents milk from dripping from filler valves when a bottle is not under the valve.

Filling by metering- Sachet Form-Fill-Seal System:

- ✓ Heat-sealable plastic film is fed continuously from a roll in the form of a strip.



Steps of Operation:

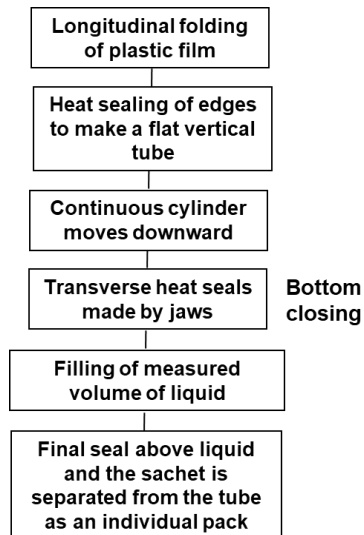

- ✓ The filling machine consists of a constant level tank with special float valve to maintain a constant head of liquid to be filled.
- ✓ The liquid milk dosing is based on the electronic time based digital circuit. After the requisite signal is received, the dispensing valve opens to allow the flow of liquid for a particular pre-set time.
- ✓ The flow of liquid is directly proportional to the time for which the valve is kept open.
- ✓ The total volume which can be dispensed in a calibrated time is a function of sp. gravity of liquid.

Piston Type Filling System- Filling by metering:

The operating valve opens by mechanical operation by metering piston.

Steps

- ✓ The metering piston sucks the liquid to be filled into the cylinder.
- ✓ The product enters from the filler bowl into the operating valve, and simultaneously closes the inlet from the operating valve to the container to be filled.
- ✓ When the cylinder is filled, the connection to the filler bowl is closed and the one to the container opened and the liquid is pushed into the container by the metering piston.
- ✓ Thin liquids as well as more viscous products can be filled with this filling system.

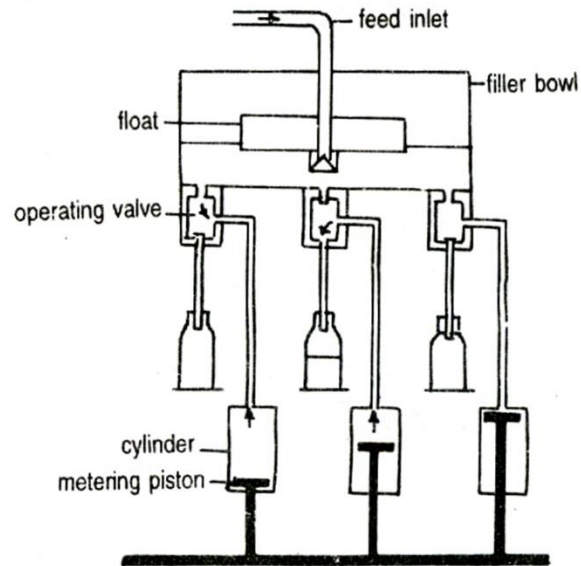

Metering Cup Filling System:

- ✓ The calibrated cup is lowered until the filler tube dips into the liquid in the filler bowl and is filled.
- ✓ Then it moves upward by the bottle pressed against it from below. The bottle seals the cup and excess liquid flows back into the filler bowl until the predetermined mark is reached.
- ✓ The discharge valve at the lower end is opened by the steering rod (located at the axis of cup and opens by pressure from upper stop position) and metered amount of liquid flows into the bottle.
- ✓ Then, as the metering cup and the bottle are lowered, the discharge valve is closed.
- ✓ The calibrated cup is again filled with liquid while the filled bottle is removed from the filler.
- ✓ Gives a high accuracy of filling

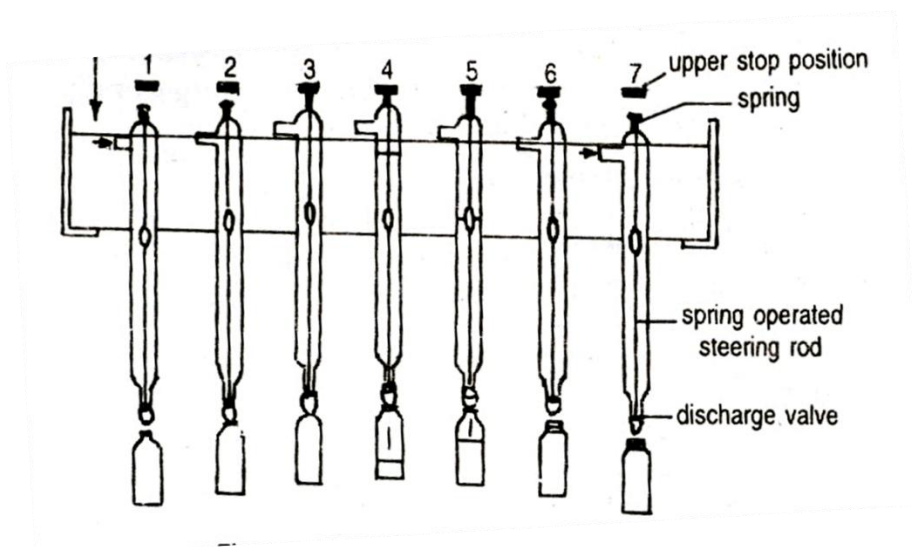

Filling of Pasty Products:

- ✓ From the filler bowl, the product is pumped (with minimum damage to the product).
- ✓ The metering time or the revolution time of the rotor is controlled by a timing relay and a magnetic coupling.
- ✓ The filler bowl level is controlled.
- ✓ This filling system can be used for liquids of low or high viscosity and even for stiff pastes, which may contain solid particles.
- ✓ There may be a mixing device in the filler bowl to evenly distribute particles, which have a tendency either to sink or to rise.

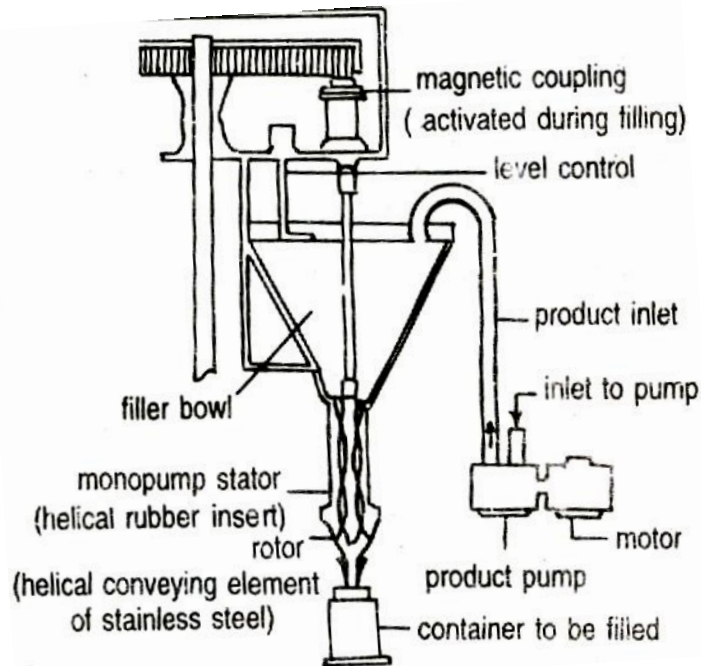

Metering and Filling of Dry Product:

- ✓ Filling of equal volumes lead generally to considerable deviations in weight, since there are deviations in bulk density.
- ✓ High mechanical pressure should be avoided to prevent the damage of product and also to prevent formation of lumps.
- ✓ A dry product which is sticky, because of high moisture content or because it is thermoplastic at too high temperature, is not suitable for continuous metering.
- ✓ The hopper should be roughly pre-dosed to a certain uniform level to obtain a uniform stream of product.

Screw metering devices:

- ✓ Either horizontal or vertical axis
- ✓ Care should be taken to ensure that the screw is properly filled with the product. This is achieved by increasing the pitch and the diameter of the thread in the direction from the outlet to the hopper, as well as installing revolving spiral bands which loosen the dry product and allow it to flow into the screw threads.
- ✓ The product mass flow rate is regulated by the number of revolution of the screw conveyor.

- ✓ The mass flow of the product is more accurate and uniform if the diameter of screw threads is smaller and the number of revolutions of the screw is higher.

Bucket wheels:

- ✓ Bucket wheels are suitable only for metering dry products into large packs since they are relatively inaccurate. Metering is not strictly continuous since the content of a whole bucket of the rotating wheel is emptied at once.

Vibrating conveyor chutes and conveyor belts:

- ✓ Suitable for continuous and accurate metering.
- ✓ By adjusting the dimensions of the orifice outlet, by installing side-walls and by regulating the frequency of the vibrations or the speed of the conveyor belt, the mass flow rate can be accurately adjusted.

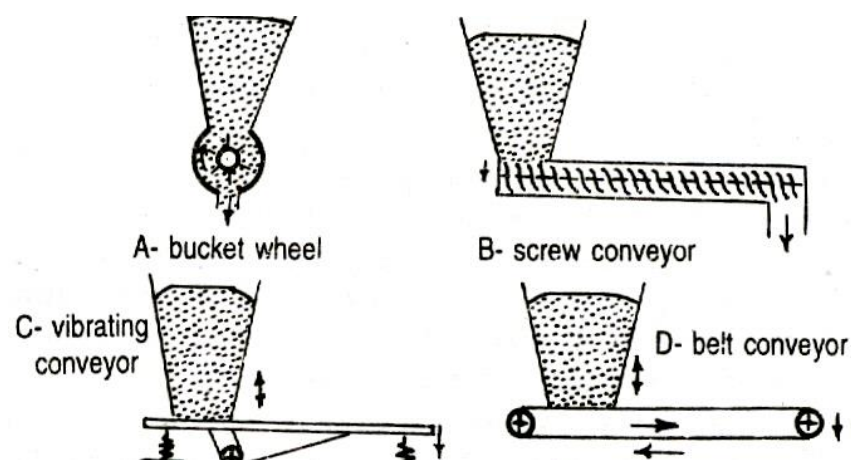

ASEPTIC FILLING:

- ✓ Container and method of closure must be suitable for aseptic filling, and must not allow the passage of organisms into the sealed container during storage and distribution.
- ✓ The container part which comes into contact with product must be sterilized after it is formed and before being filled.
- ✓ Filling must be without contamination.
- ✓ The closure must be sterilized immediately before it is applied and sealed in place while the container is still within a sterile zone to prevent the passage of organisms.

ASEPTIC FILLING for plastic pouches:

- ✓ The packaging material is fed as a continuous strip from a roll.
- ✓ The pouch forming, filling, and sealing operations take place within a sealed chamber supplied with sterilized air.
- ✓ The air is sterilized by a bacterial filter which is capable of removing 99.9% of particles of 0.3 μm diameter.
- ✓ The film enters the chamber through a bath of H_2O_2 solution, where it remains for a minimum of 20s when 1-litre pouches are being filled. (With smaller pouches. the film feed rate is lower and the sterilizing time is increased.)
- ✓ At the outlet of the bath. the film passes through mechanical scrapers which removes surplus liquid.

- ✓ The film then passes through the flow of sterile air supplied to the filling chamber at a temperature of 45°C. The air removes the peroxide from film (Final H₂O₂ concentration in the filled pouch < 1 ppm).
- ✓ The film is moved forward by grippers intermittently to produce a single pouch.
- ✓ First folding longitudinally and heat sealing by vertical sealing jaws → a flat tube formed over the length of a pouch.
- ✓ The transverse seal of the previous pouch closes the bottom of the tube.
- ✓ The product is filled in fixed and controllable volume through a vertical tube and filling nozzle.

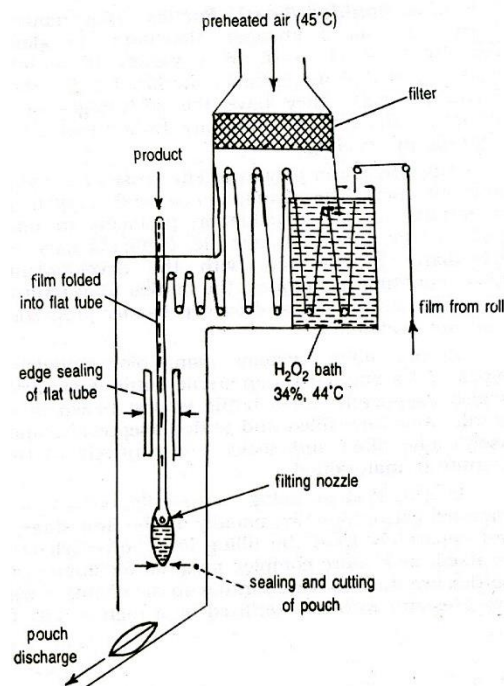

- ✓ The filler is usually of piston type.
- ✓ Volume of filling ← travel of the piston
- ✓ For low viscosity products, the filler is supplied by gravity from a balance tank.
- ✓ Pump for more viscous products.
- ✓ When filling is complete, the tube is moved down by the length of a pouch, and the top is sealed and cut so that the filled pouch is detached and the bottom of the next is made at the same time.
- ✓ The filler consists of two filling heads with a single aseptic chamber and each can operate independently of the other and can fill different sizes of pouch at the same time.

ASEPTIC FILLING for blow moulded plastic bottles:

Aseptic filling systems using blow-moulded bottles are of three types:

1. A standard non-sterile bottle is sterilized and then filled and sealed aseptically.
2. A bottle is first blown in such a way that it is sterile, and then filled and sealed aseptically.
3. A bottle is blown aseptically, filled and sealed consecutively at the same time so that sterility is maintained.

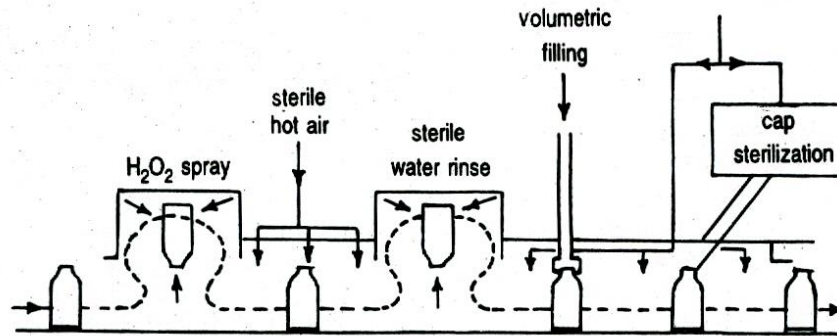

Fig. System using non-sterile bottles

1. Bottle is blown and trimmed conventionally usually as the first stage of the aseptic process, but separately from the filling line.
2. The bottles are then conveyed into a sterile chamber, which is kept at a slight overpressure with air sterilized by a high quality filter.
3. The bottles are inverted and sprayed inside and outside with H_2O_2 solution.
4. The bottles are then erected, which pass through a hot air tunnel in which the peroxide is evaporated and the vapours removed.
5. Bottles are then re-inverted, rinsed inside and out with sterile water and erected again.
6. The bottles are filled using a rotary volumetric filler.
7. The headspace is filled with an inert gas if necessary.
8. The bottles are then heat sealed with chemically sterilized plastics film or other heat-sealable closure, and an outer plug or screw cap can be applied.
9. The sterile air is supplied from above in a laminar flow system to the parts of the sterile chamber where the bottles are finally rinsed, filled and sealed.
10. The bottles then leave the sterile chamber and is ready for distribution.

Lecture 21

DAIRY PLANT LAYOUT

Plant layout is the arrangement of equipment/ machines/ facilities in a plant for the efficient functioning of the whole system with a view to maximize the profit.

We may consider any food processing operation as a transformation process. In a fruits and vegetables processing plant, the raw materials (raw fruits and vegetables) are transformed into finished product (processed fruits and vegetables) by a series of operations, whose sequence and numbers are specified for the input. For example, the sequence of operations that are carried out in an onion dehydration plant, can be shown as in Fig.

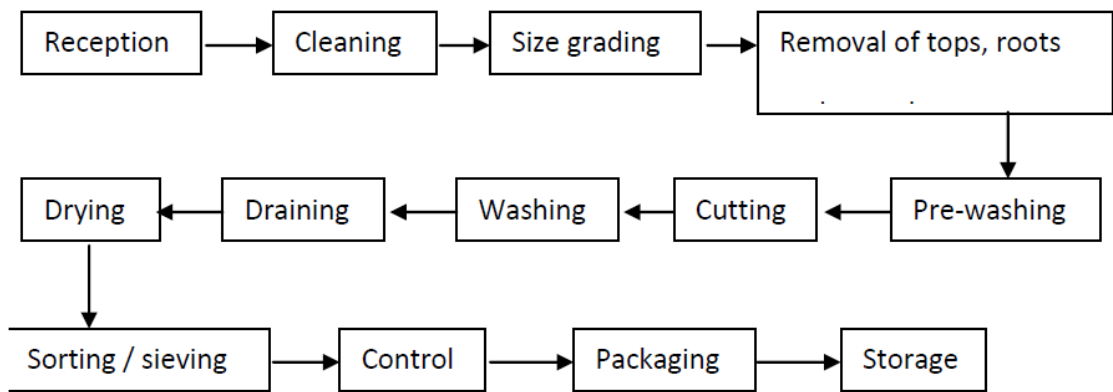

Fig: Preparation of dehydrated onion

We cannot change the sequence of these operations as per our desire. In this case, after receiving, the dust and dirt sticking to the surface of the onion bulbs must be cleaned first. Then the bulbs should be graded for size, then the tops and roots be removed, and so on. Therefore, for efficient utilization of energy, labor (these are the other inputs than the raw materials), and of course money, the cleaning section should be kept adjacent to the receiving section followed by the grading section, and so on.

Now, suppose we place the size grader between the receiving yard and the cleaning section or the drying section between the packaging section and storage section, what do you think will happen? It will unnecessarily increase the materials handling cost and time, and reduce overall performance. In addition, it will also cause collision between the workers and wastage of manpower and energy. Hence, we should arrange the work areas, equipment and auxiliary facilities judiciously in the processing plant such that the operation will be economical and the employees will feel safe and satisfying.

Thus, the arrangement of the different facilities and equipment in a food processing plant plays an important role in the overall viability of the project. This physical arrangement of the industrial facilities is known as plant layout. The arrangement also includes the space needed for material movement, storage, indirect labor and all other supporting activities, or services, as well as for operating equipment and personnel.

Advantages of good plant layout

In general, a good plant layout will permit simple and forward movement for the product and containers through the plant. Let us take a simple example.

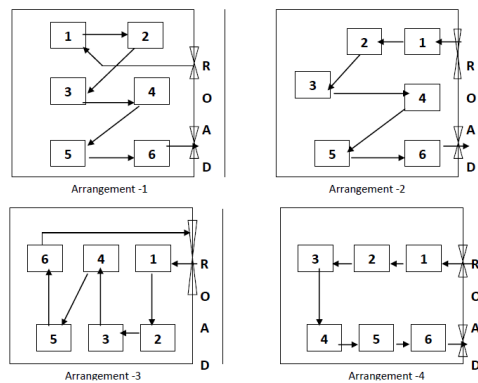

In the above Fig., I have shown you some equipment in boxes, in which the numbers show the sequence of operations. Say, the first operation (may be cleaning) will be done by the Equipment-1, the second operation by Equipment-2 and so on. The Equipment-6 does the packing and then the product has to be taken out of the factory. I have shown you four possible arrangements for these equipment. Which pattern or arrangement do you think will be the best to reduce the cost of operation and improve performance?

Obviously Arrangement No.4 will be the most ideal one. Remember, we are yet to learn the general guidelines for a good plant layout. However, you will definitely agree that if the machines are not properly arranged, as in the cases 1, 2 or 3, the total material movement inside the plant is unnecessarily increased. Besides, there is also crossing of the flow paths, which would interrupt a smooth operation. The sequence of operations is one of the major criteria, but not the only criteria for designing plant layout, which we will discuss later in the unit. But as we are discussing about the advantages of a good plant layout, we see that a proper plant layout helps us in reducing cost of operation, which is very important for survival of any industry.

A good plant layout, in general, has the following advantages.

- Saving in floor space;
- Better utilization of machine and man power, and services;
- Reduced material handling, thus saving in labor and cost, less production delays;
- Reduced inventory in process, thus saving in investment and working capital;
- Increased output/ production per unit time, labor, money and energy; and
- Easier and better supervision

In addition to the above, a properly designed layout helps to maintain proper sanitation and safety standards in a plant. It reduces confusion between different sections of workers, and improves moral of the workers. All these factors directly affect the output. Careful layout planning can identify and remedy bottlenecks and trouble spots before the plant is built, and thus prevents troubles later.

Requirements / factors in planning layouts

As we have already discussed, the basic objectives of a good plant layout are smooth operation and reduced cost in handling and processing. Good layout must also include arrangement of specified areas for processing, storage and handling in efficient coordination. This should also consider the following factors.

- Proper placement of equipment and conveying machines- All the equipment and conveying machines should be arranged in proper coordination depending on the flow sequence and characteristics of equipment. Depending on requirements, the layout can be single level, multi storied, or combined designs.
- Economic distribution of services- The layout, in addition to proper placement of important equipment, should also have provision for efficient and economic distribution of water, process steam, power, and gas, etc. The distribution lines for these utilities should not interrupt the normal working of the people.

- Suitable use of floor and elevation space- This will depend on the type of food processing plant and the special facilities and equipment used for the system.

- New site development or addition to a previously developed site- If we want to plan the plant on a site, which already has some installed equipment, office rooms and storage godowns, etc., then the layout should consider these amenities. Our objectives will be to see that minimum alterations or modifications are made to the existing facilities without affecting the overall objective of the layout.

- Future expansion- The layout should have sufficient provision for future expansion. Suppose at this stage we are interested in a 1 tph (tonnes per hour) dehydration plant for ginger. But after some years, we want to increase the capacity to 4 tph or want to prepare dehydrated onion and garlic from the same plant. It requires installation of some more equipment. We will also need more space for go down and processing operations. In that case, we will be in trouble if the present arrangement doesn't have sufficient provision for expansion. Another alternative is to install a completely new plant in another location. It will involve some unnecessary cost and further it will also be difficult to manage two plants at two different locations. To overcome such type of difficulties, the layout should have provision for future expansion.

- Waste disposal problems- The layout should have adequate provision for disposal of solid, liquid and gaseous wastes. Or else, the project may not be even passed by the pollution control authorities.

- Safety considerations- We should keep the equipment or areas having chances of hazards like fire or explosion away from normal working of the people. For example, we should isolate the boiler room.

- Other factors - The building code requirement, weather conditions like extreme high or low temperatures, maximum wind speed in the area, etc. are some other factors which need to be considered during planning the layout.

Types of layouts

- There are generally two types of product flow in food processing industry, namely, line flow process and intermittent flow process. In the line flow process, the product flows from one operation to the next in a prescribed sequence as in the preparation of homogenized and pasteurised milk in an automatic dairy plant. The individual work tasks are closely coupled. There may be side flows, which impinge on this line, but they are integrated to achieve a smooth flow. In an intermittent flow process the production is carried out in batches at intermittent intervals. In this case, we can organize the equipment and labor into different work centers by similar types of skill or equipment. The product can be sent to any of the work centers as per requirement. For example, in a mango processing plant, the mango slices can be sent to a dehydrator for preparing dried mango slices or sent to the canning section for getting canned mango slices, or may be filled with syrup and frozen to prepare frozen mango slices. Similarly mango pulp can be processed in different work centers to get frozen mango pulp, mango squash, mango nectar, mango bar, mango powder or mango cereal flakes. Or, say the particular squash manufacturing section can be used for different commodities like mango, pineapple, lime or watermelon at different times. This often results in a jumbled pattern of flow. The volume of product handling can be changed easily in this type of flow.

LINE FLOW- PRODUCT FORM OF LAYOUT

INTERMITTENT FLOW-PROCESS FORM OF LAYOUT

- Based on the above classification of flow processes, the layouts also differ. The intermittent process is also known as a process form of layout as similar equipment and processing operations are grouped together. It is also known as 'layout by function'. The line flow is also called a product form of layout because various process equipment, and labor skills are put into sequence according to the way the product is made.
- When a product lacks standardization or the volume of product is low, the intermittent operation is economical and involves least risk. If an industry produces high volume of one or a few products, then layout by product or flow-line layout can be used. The equipment is placed in sequence, either on a straight line, or in shapes like U, L or convoluted or serpentine shape. As the raw material is processed, some products and by- products may move away from the principal direction of the flow.
- Many modifications to above flow patterns are possible. A hybrid layout is one, where some portions may be layout by process and some portions by product. Generally the small food processing plants have process form of layout, whereas bigger industries have hybrid layouts.
- Another type of classification of layout is single level, multi-storey or combined layout.