

Chapter 3

Data Modeling Using the Entity-Relationship (ER) Model

Chapter Outline

- Example Database Application (COMPANY)
- ER Model Concepts
 - Entities and Attributes
 - Entity Types, Value Sets, and Key Attributes
 - Relationships and Relationship Types
 - Weak Entity Types
 - Roles and Attributes in Relationship Types
- ER Diagrams - Notation
- ER Diagram for COMPANY Schema
- Alternative Notations – UML class diagrams, others

Example COMPANY Database

- Requirements of the Company (oversimplified for illustrative purposes)
 - The company is organized into DEPARTMENTS. Each department has a name, number and an employee who *manages* the department. We keep track of the start date of the department manager.
 - Each department *controls* a number of PROJECTS. Each project has a name, number and is located at a single location.

Example COMPANY Database (Cont.)

- We store each EMPLOYEE's social security number, address, salary, sex, and birthdate. Each employee *works for* one department but may *work on* several projects. We keep track of the number of hours per week that an employee currently works on each project. We also keep track of the *direct supervisor* of each employee.
- Each employee may *have* a number of DEPENDENTS. For each dependent, we keep track of their name, sex, birthdate, and relationship to employee.

ER Model Concepts

● Entities and Attributes

- Entities are specific objects or things in the mini-world that are represented in the database. For example the EMPLOYEE John Smith, the Research DEPARTMENT, the ProductX PROJECT
- Attributes are properties used to describe an entity. For example an EMPLOYEE entity may have a Name, SSN, Address, Sex, BirthDate
- A specific entity will have a value for each of its attributes. For example a specific employee entity may have Name='John Smith', SSN='123456789', Address ='731, Fondren, Houston, TX', Sex='M', BirthDate='09-JAN-55'
- Each attribute has a *value set* (or data type) associated with it – e.g. integer, string, subrange, enumerated type, ...

Types of Attributes (1)

- Simple
 - Each entity has a single atomic value for the attribute. For example, SSN or Sex.
- Composite
 - The attribute may be composed of several components. For example, Address (Apt#, House#, Street, City, State, ZipCode, Country) or Name (FirstName, MiddleName, LastName). Composition may form a hierarchy where some components are themselves composite.
- Multi-valued
 - An entity may have multiple values for that attribute. For example, Color of a CAR or PreviousDegrees of a STUDENT. Denoted as {Color} or {PreviousDegrees}.

Types of Attributes (2)

- In general, composite and multi-valued attributes may be nested arbitrarily to any number of levels although this is rare. For example, PreviousDegrees of a STUDENT is a composite multi-valued attribute denoted by {PreviousDegrees (College, Year, Degree, Field)}.

Entity Types and Key Attributes

- Entities with the same basic attributes are grouped or typed into an entity type. For example, the EMPLOYEE entity type or the PROJECT entity type.
- An attribute of an entity type for which each entity must have a unique value is called a key attribute of the entity type. For example, SSN of EMPLOYEE.
- A key attribute may be composite. For example, VehicleTagNumber is a key of the CAR entity type with components (Number, State).
- An entity type may have more than one key. For example, the CAR entity type may have two keys:
 - VehicleIdentificationNumber (popularly called VIN) and
 - VehicleTagNumber (Number, State), also known as license_plate number.

ENTITY SET corresponding to the ENTITY TYPE CAR

CAR

Registration(RegistrationNumber, State), VehicleID, Make, Model, Year, (Color)

car_1

((ABC 123, TEXAS), TK629, Ford Mustang, convertible, 1999, (red, black))

car_2

((ABC 123, NEW YORK), WP9872, Nissan 300ZX, 2-door, 2002, (blue))

car_3









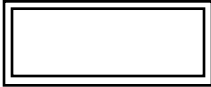

((VSY 720, TEXAS), TD729, Buick LeSabre, 4-door, 2003, (white, blue))

.

.

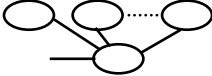
.

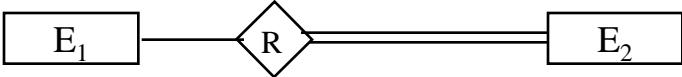
SUMMARY OF ER-DIAGRAM NOTATION FOR ER SCHEMAS

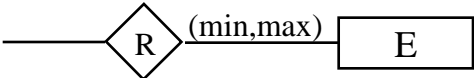
<u>Symbol</u>	<u>Meaning</u>
	ENTITY TYPE
	WEAK ENTITY TYPE
	RELATIONSHIP TYPE
	IDENTIFYING RELATIONSHIP TYPE
	ATTRIBUTE
	KEY ATTRIBUTE
	MULTIVALUED ATTRIBUTE
	COMPOSITE ATTRIBUTE
	DERIVED ATTRIBUTE
	TOTAL PARTICIPATION OF E ₂ IN R
	CARDINALITY RATIO 1:N FOR E ₁ :E ₂ IN R
	STRUCTURAL CONSTRAINT (min, max) ON PARTICIPATION OF E IN R

ER DIAGRAM – Entity Types are: EMPLOYEE, DEPARTMENT, PROJECT, DEPENDENT

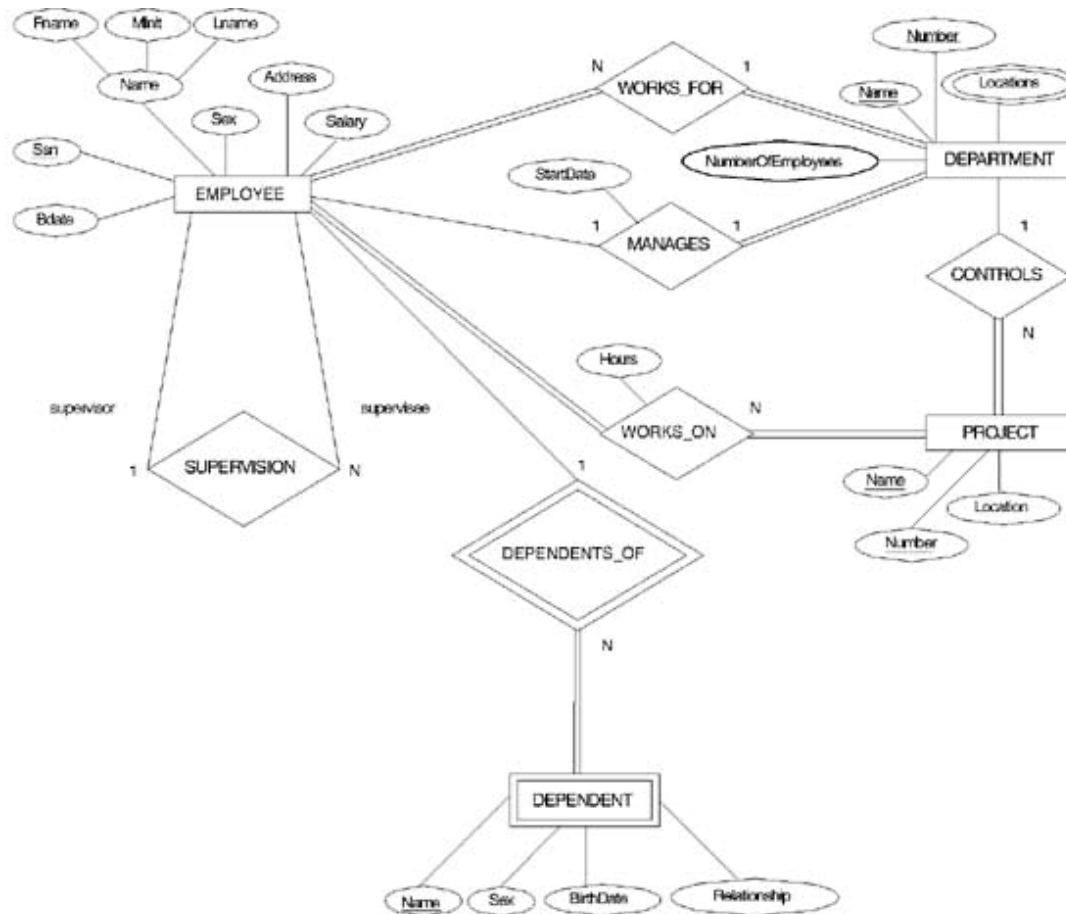

Relationships and Relationship Types (1)

- A relationship relates two or more distinct entities with a specific meaning. For example, EMPLOYEE John Smith works on the ProductX PROJECT or EMPLOYEE Franklin Wong manages the Research DEPARTMENT.
- Relationships of the same type are grouped or typed into a relationship type. For example, the WORKS_ON relationship type in which EMPLOYEEs and PROJECTs participate, or the MANAGES relationship type in which EMPLOYEEs and DEPARTMENTs participate.
- The degree of a relationship type is the number of participating entity types. Both MANAGES and WORKS_ON are binary relationships.

Example relationship instances of the WORKS_FOR relationship between EMPLOYEE and DEPARTMENT

EMPLOYEE

WORKS_FOR

DEPARTMENT

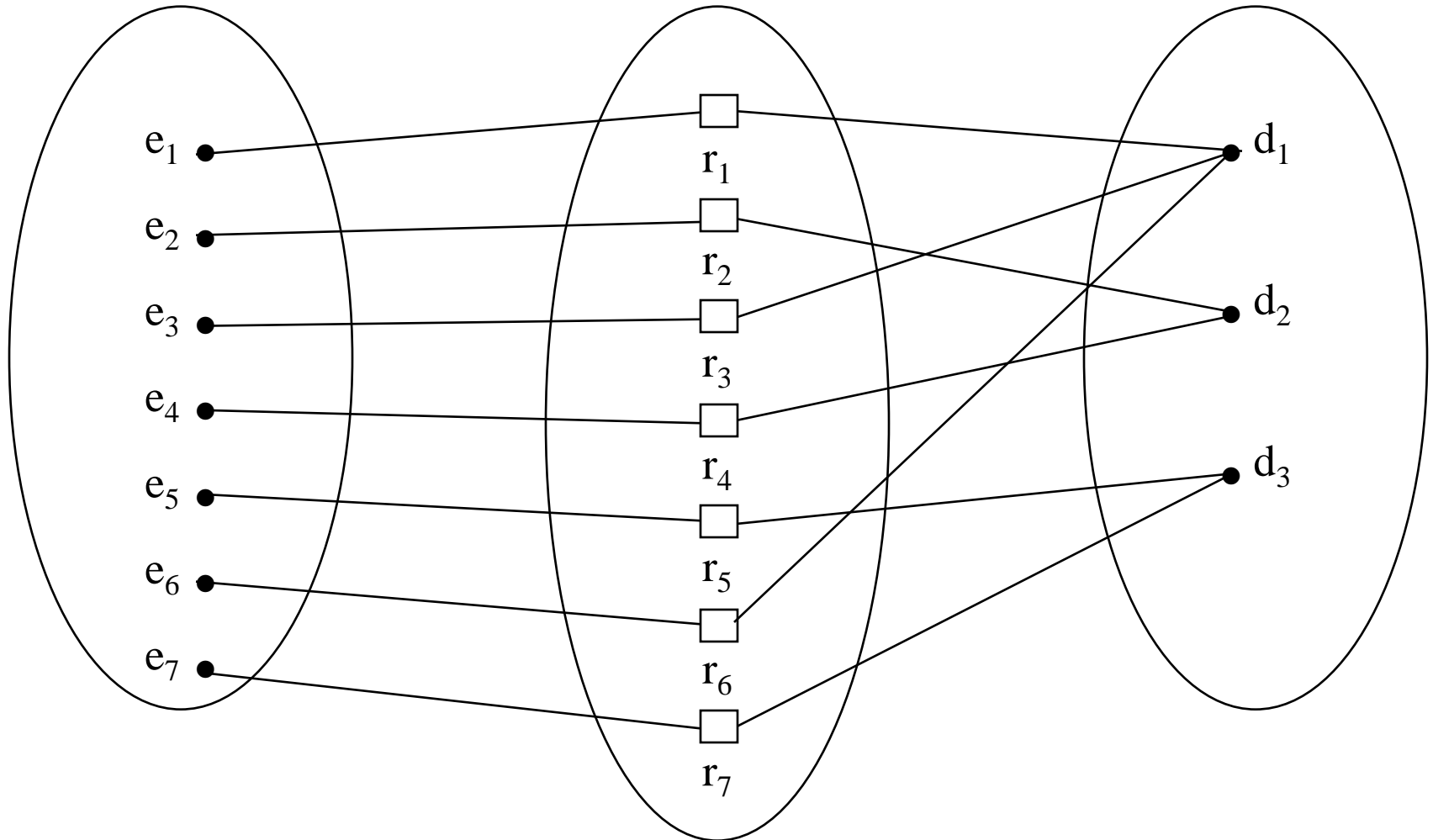

Example relationship instances of the WORKS_ON relationship between EMPLOYEE and PROJECT

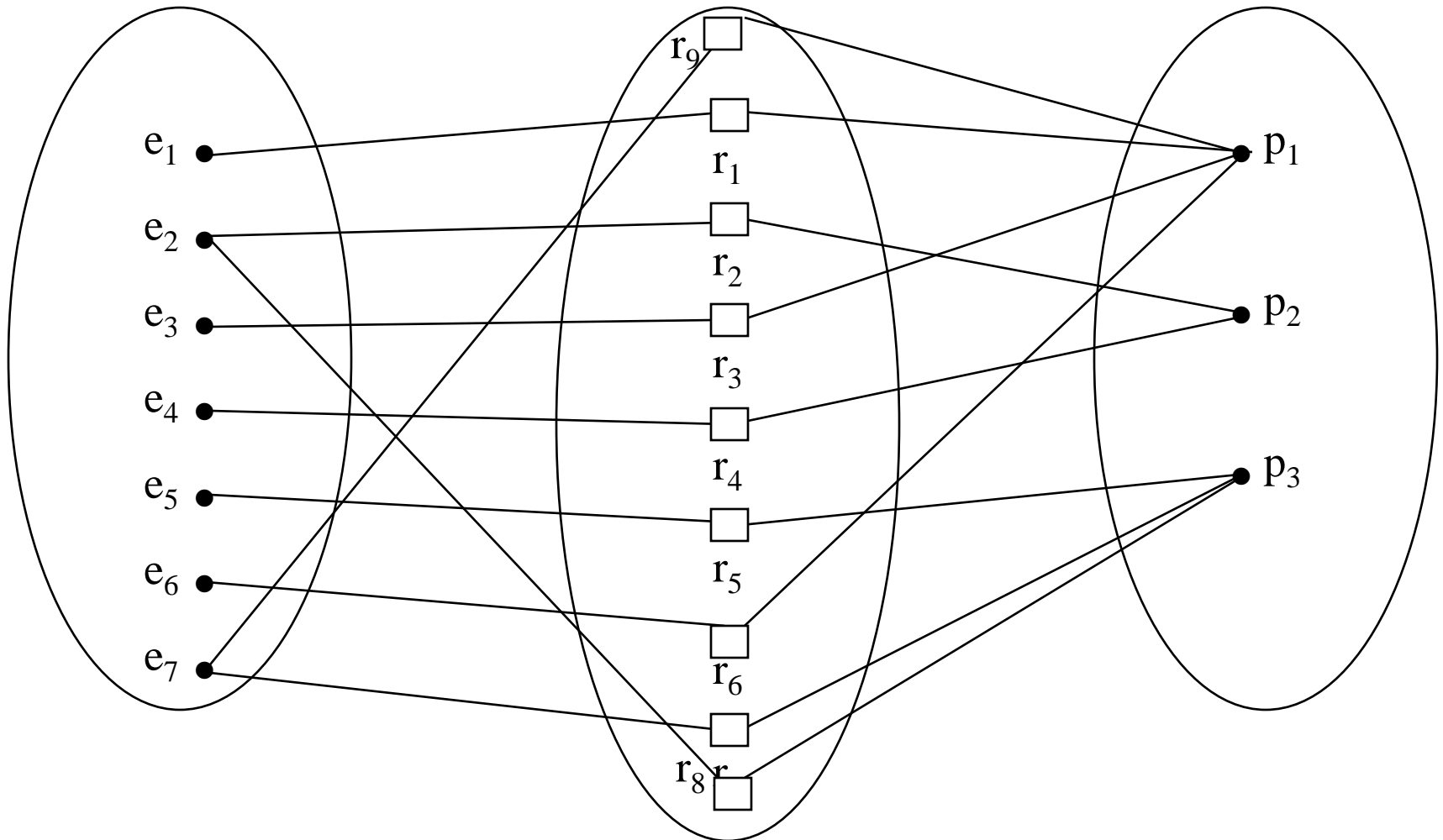

Relationships and Relationship Types (2)

- More than one relationship type can exist with the same participating entity types. For example, MANAGES and WORKS_FOR are distinct relationships between EMPLOYEE and DEPARTMENT, but with different meanings and different relationship instances.

ER DIAGRAM – Relationship Types are: WORKS_FOR, MANAGES, WORKS_ON, CONTROLS, SUPERVISION, DEPENDENTS_OF

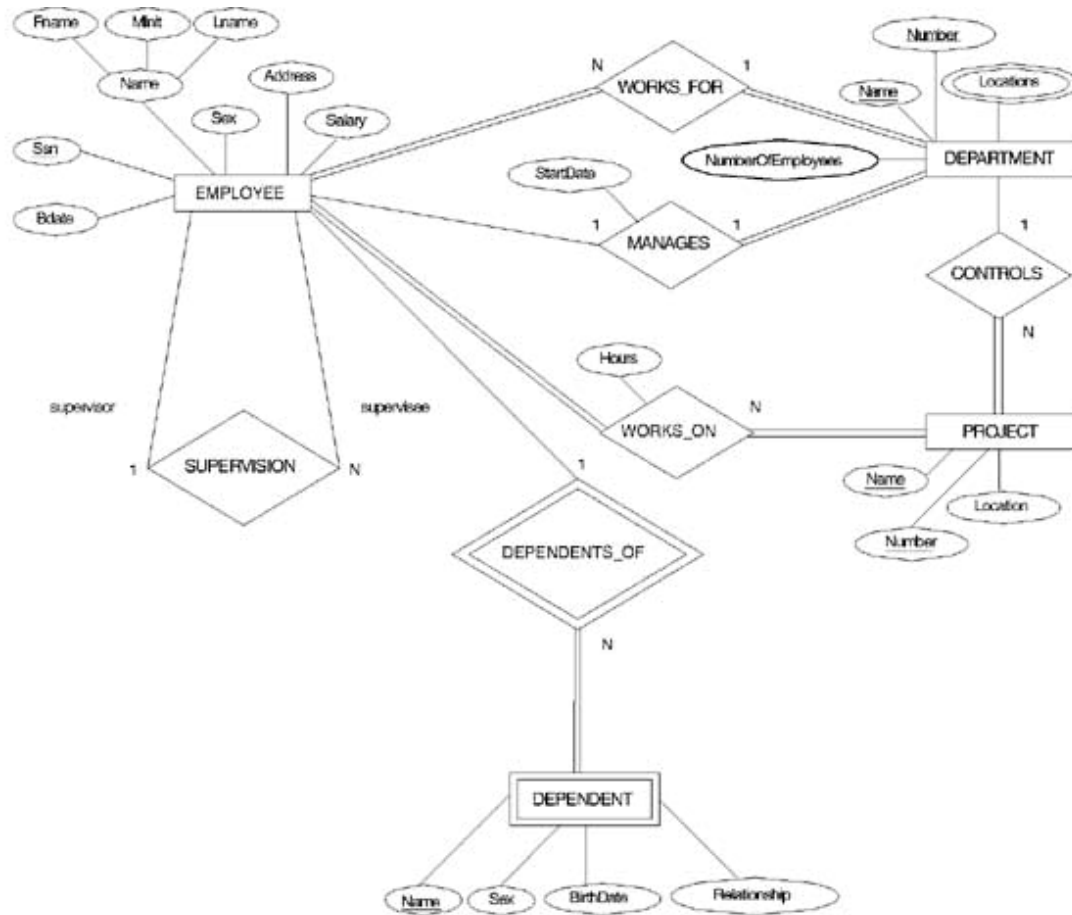

Weak Entity Types

- An entity that does not have a key attribute
- A weak entity must participate in an identifying relationship type with an owner or identifying entity type
- Entities are identified by the combination of:
 - A partial key of the weak entity type
 - The particular entity they are related to in the identifying entity type

Example:

Suppose that a `DEPENDENT` entity is identified by the dependent's first name and birthdate, *and* the specific `EMPLOYEE` that the dependent is related to. `DEPENDENT` is a weak entity type with `EMPLOYEE` as its identifying entity type via the identifying relationship type `DEPENDENT_OF`

Weak Entity Type is: DEPENDENT

Identifying Relationship is: DEPENDENTS_OF

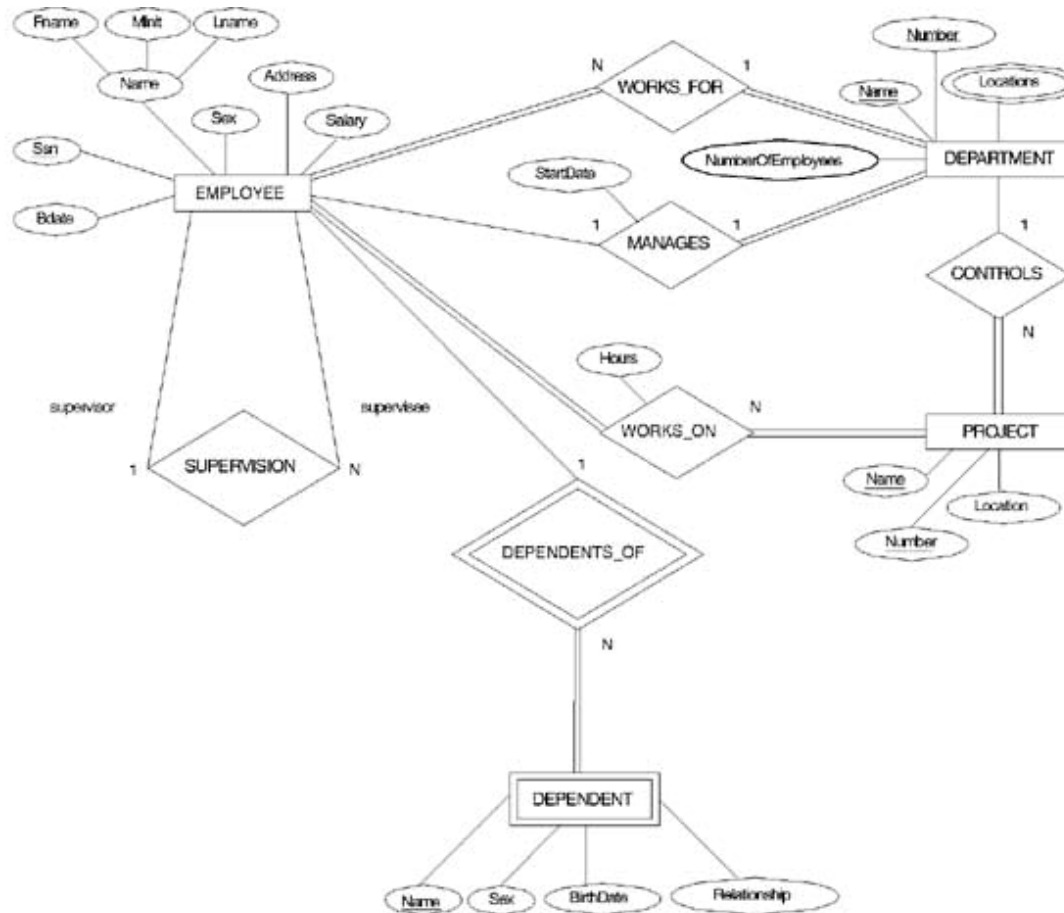

Constraints on Relationships

- Constraints on Relationship Types
 - (Also known as ratio constraints)
 - Maximum Cardinality
 - One-to-one (1:1)
 - One-to-many (1:N) or Many-to-one (N:1)
 - Many-to-many
 - Minimum Cardinality (also called participation constraint or existence dependency constraints)
 - zero (optional participation, not existence-dependent)
 - one or more (mandatory, existence-dependent)

Many-to-one (N:1) RELATIONSHIP

EMPLOYEE

WORKS_FOR

DEPARTMENT

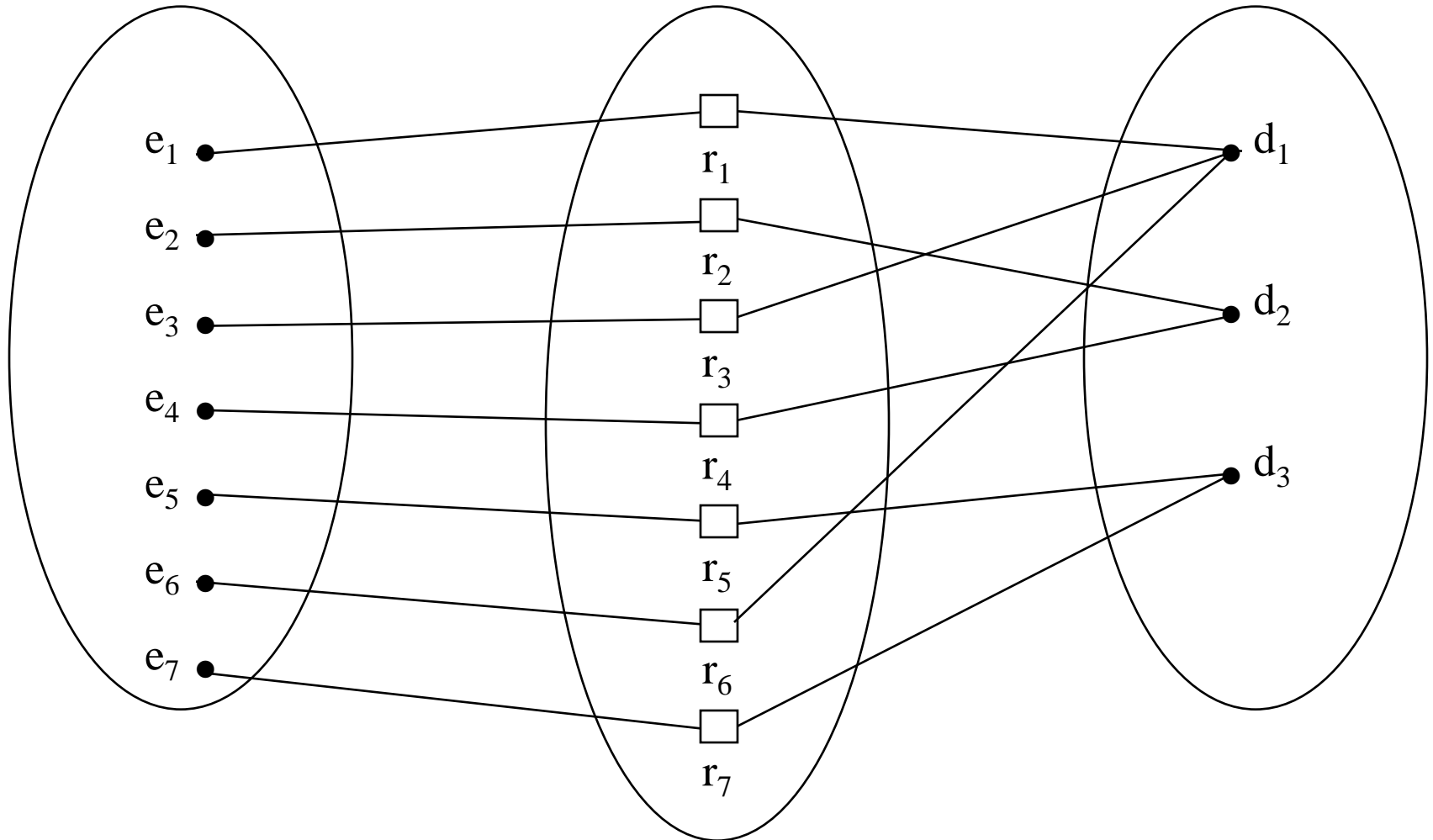

Many-to-many (M:N) RELATIONSHIP

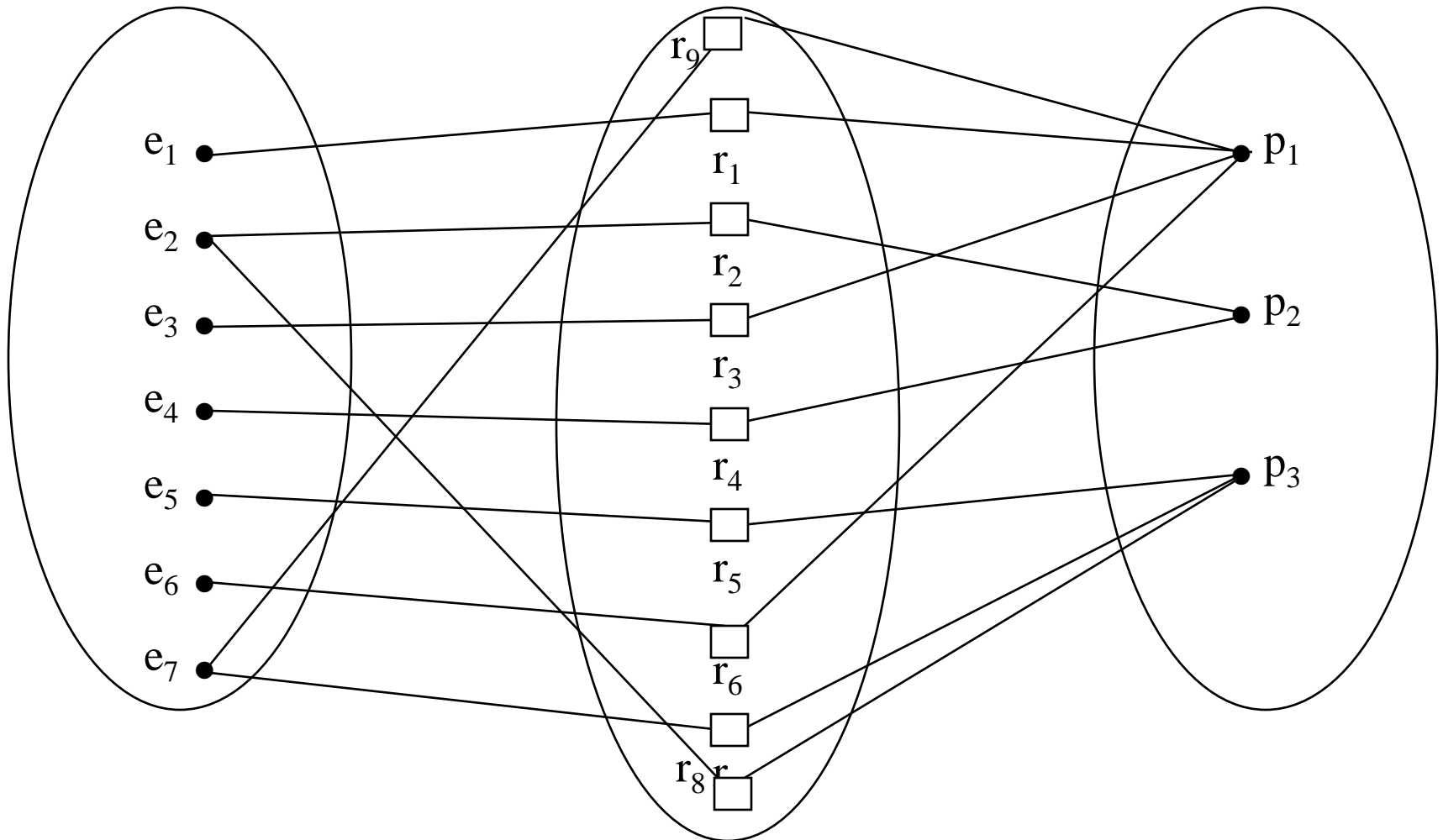

Relationships and Relationship Types (3)

- We can also have a **recursive** relationship type.
- Both participations are same entity type in different roles.
- For example, SUPERVISION relationships between EMPLOYEE (in role of supervisor or boss) and (another) EMPLOYEE (in role of subordinate or worker).
- In following figure, first role participation labeled with 1 and second role participation labeled with 2.
- In ER diagram, need to display role names to distinguish participations.

A RECURSIVE RELATIONSHIP SUPERVISION

EMPLOYEE

SUPERVISION

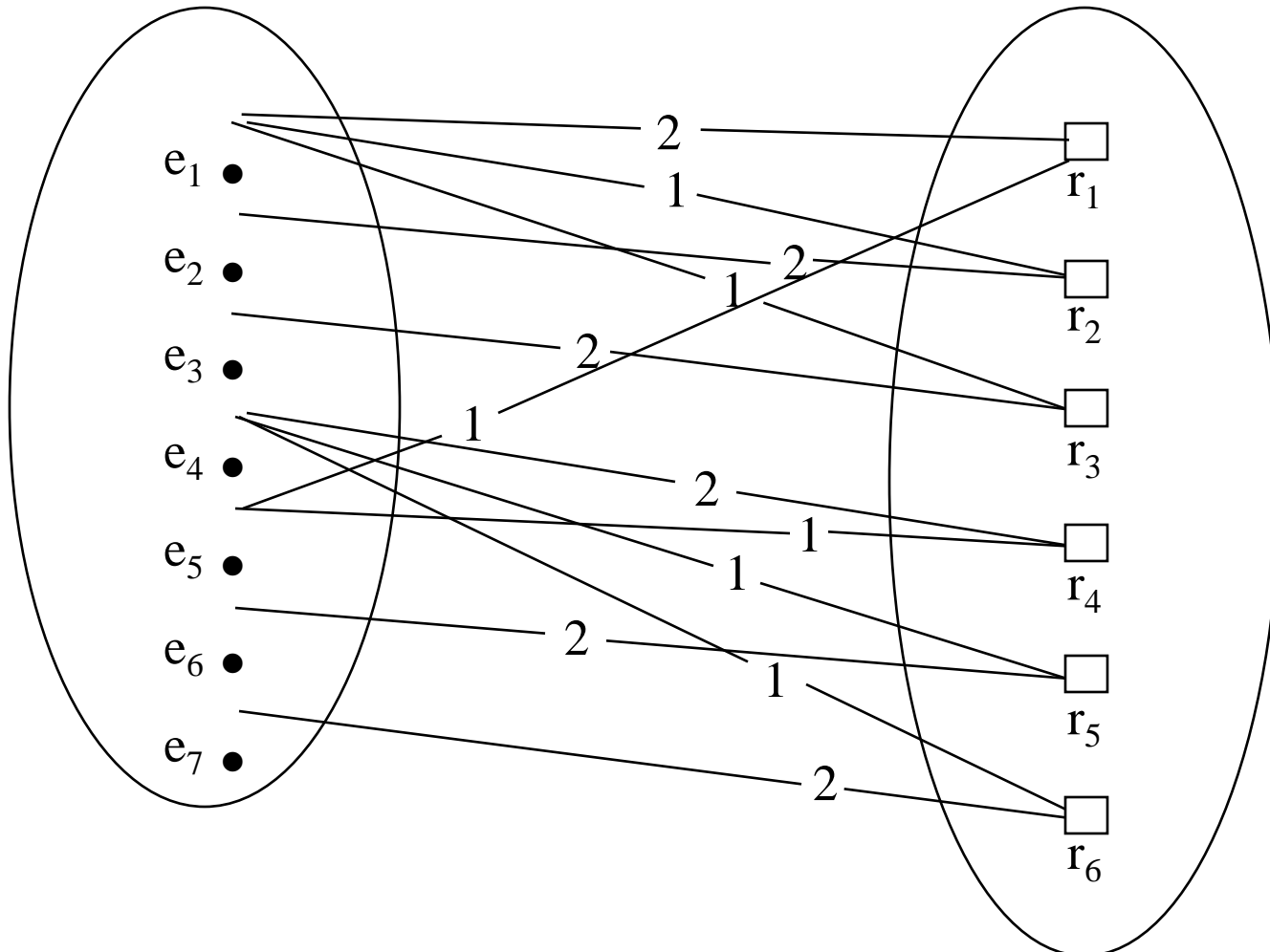

Recursive Relationship Type is: SUPERVISION (participation role names are shown)

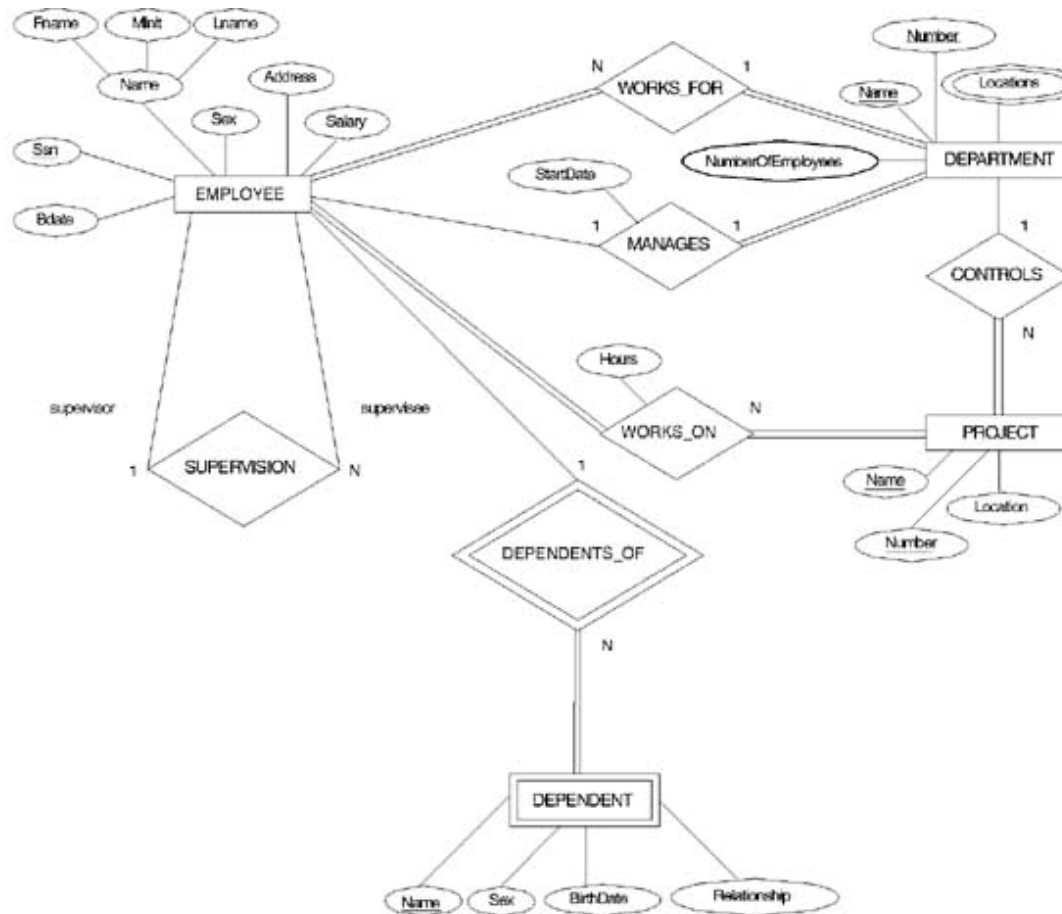

Attributes of Relationship types

- A relationship type can have attributes; for example, HoursPerWeek of WORKS_ON; its value for each relationship instance describes the number of hours per week that an EMPLOYEE works on a PROJECT.

Attribute of a Relationship Type is: Hours of WORKS_ON

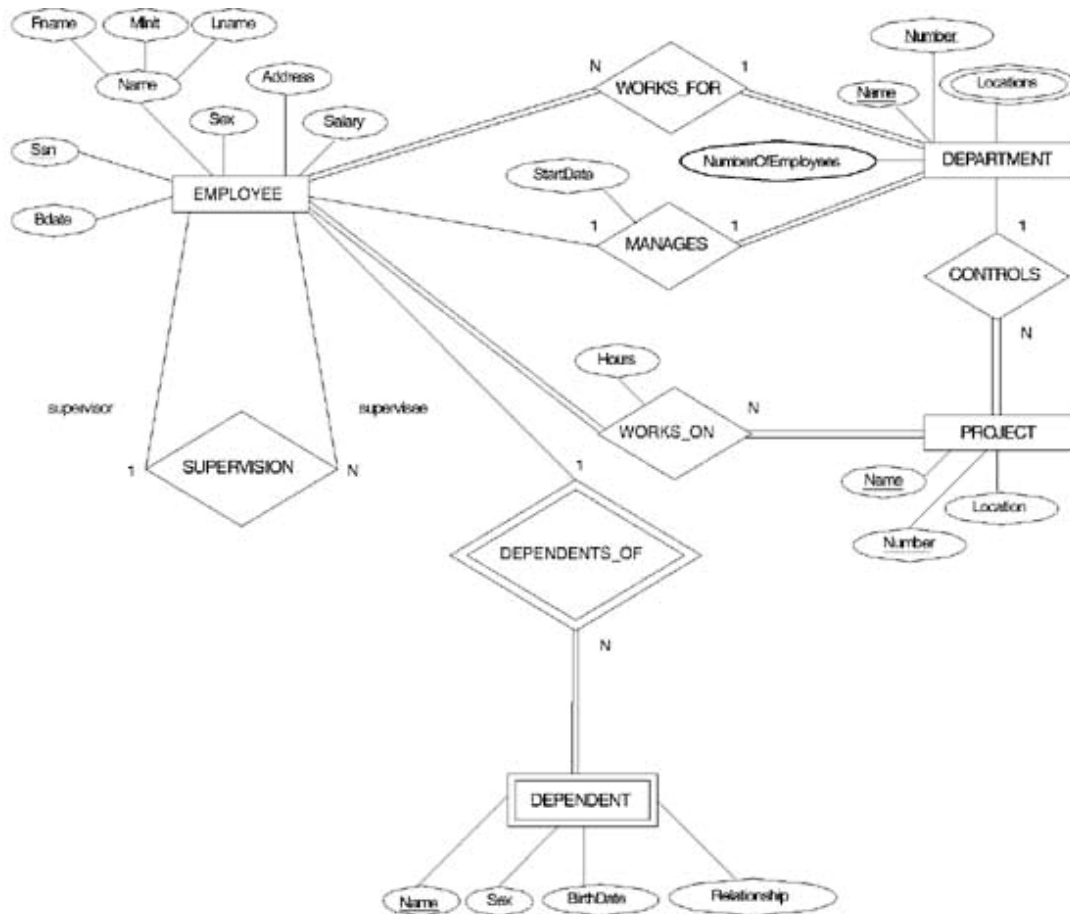

Structural Constraints – one way to express semantics of relationships

Structural constraints on relationships:

- **Cardinality ratio** (of a binary relationship): 1:1, 1:N, N:1, or M:N

SHOWN BY PLACING APPROPRIATE NUMBER ON THE LINK.

- **Participation constraint** (on each participating entity type): total (called *existence dependency*) or partial.

SHOWN BY DOUBLE LINING THE LINK

NOTE: These are easy to specify for Binary Relationship Types.

Alternative (min, max) notation for relationship structural constraints:

- Specified on *each participation* of an entity type E in a relationship type R
- Specifies that each entity e in E participates in *at least* min and *at most* max relationship instances in R
- Default(no constraint): min=0, max=n
- Must have $\text{min} \leq \text{max}$, $\text{min} \geq 0$, $\text{max} \geq 1$
- Derived from the knowledge of mini-world constraints

Examples:

- A department has *exactly one* manager and an employee can manage *at most one* department.
 - Specify (0,1) for participation of EMPLOYEE in MANAGES
 - Specify (1,1) for participation of DEPARTMENT in MANAGES
- An employee can work for *exactly one* department but a department can have *any number of employees*.
 - Specify (1,1) for participation of EMPLOYEE in WORKS_FOR
 - Specify (0,n) for participation of DEPARTMENT in WORKS_FOR

The (min,max) notation relationship constraints

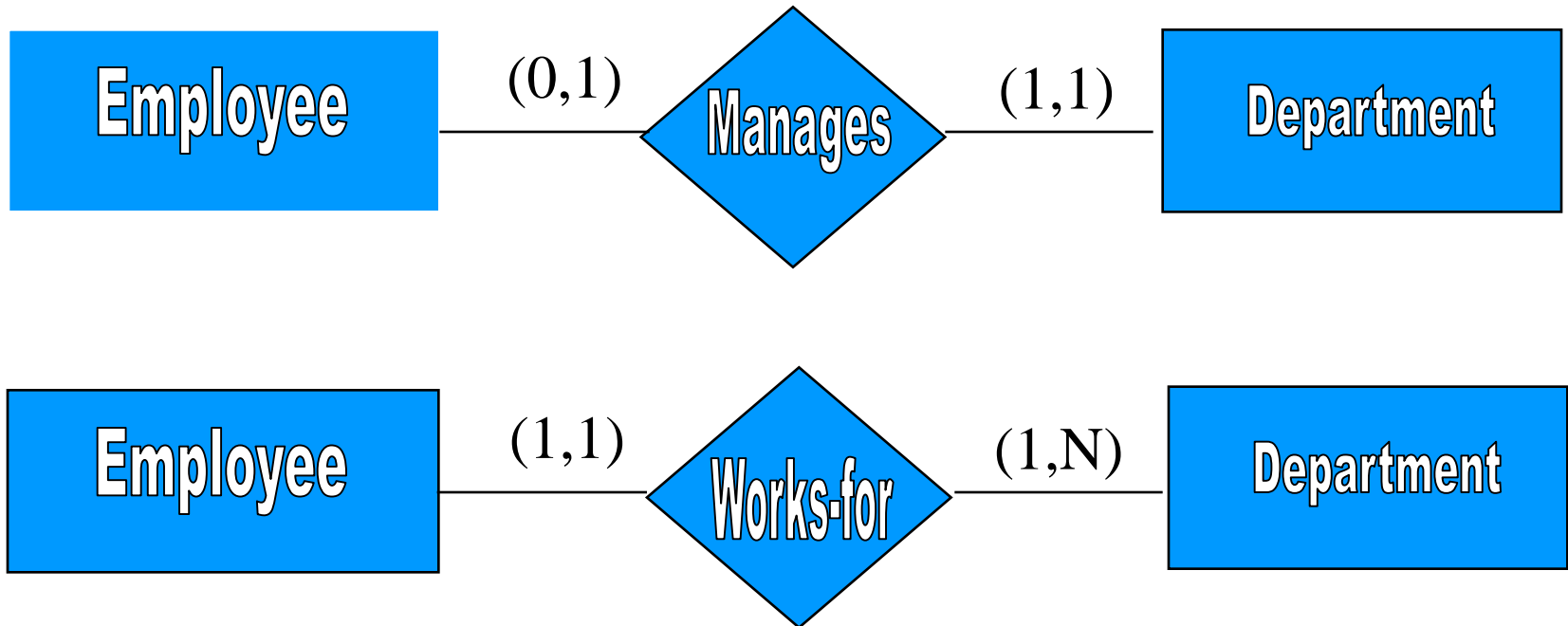

COMPANY ER Schema Diagram using (min, max) notation

Alternative ER Notations

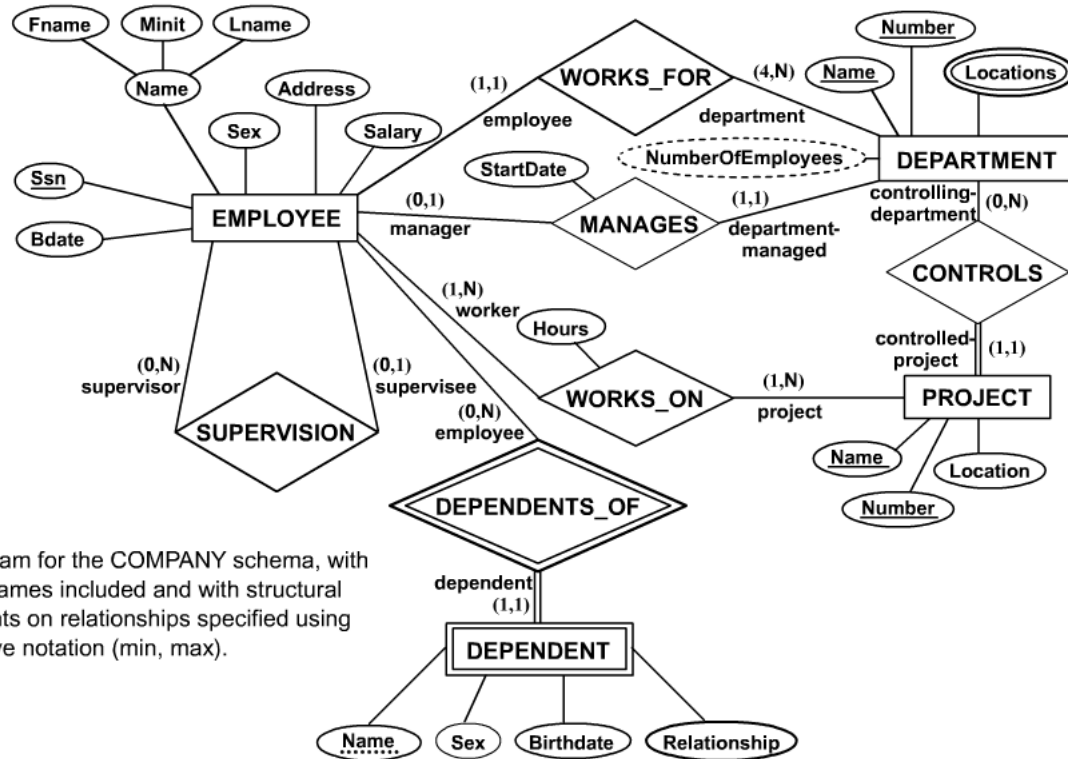

ER diagram for the COMPANY schema, with all role names included and with structural constraints on relationships specified using alternative notation (min, max).

Relationships of Higher Degree

- Relationship types of degree 2 are called **binary**
- Relationship types of degree 3 are called **ternary** and of degree n are called **n-ary**
- In general, an n -ary relationship *is not* equivalent to n binary relationships
- Higher-order relationships discussed further in Chapter 4

Data Modeling Tools

A number of popular tools that cover conceptual modeling and mapping into relational schema design. Examples: ERWin, S- Designer (Enterprise Application Suite), ER- Studio, etc.

POSITIVES: serves as documentation of application requirements, easy user interface - mostly graphics editor support

Problems with Current Modeling Tools

● DIAGRAMMING

- Poor conceptual meaningful notation.
- To avoid the problem of layout algorithms and aesthetics of diagrams, they prefer boxes and lines and do nothing more than represent (primary-foreign key) relationships among resulting tables.(a few exceptions)

● METHODOLOGY

- lack of built-in methodology support.
- poor tradeoff analysis or user-driven design preferences.
- poor design verification and suggestions for improvement.

Some of the Currently Available Automated Database Design Tools

COMPANY	TOOL	FUNCTIONALITY
Embarcadero Technologies	ER Studio	Database Modeling in ER and IDEF1X
	DB Artisan	Database administration and space and security management
Oracle	Developer 2000 and Designer 2000	Database modeling, application development
Popkin Software	System Architect 2001	Data modeling, object modeling, process modeling, structured analysis/design
Platinum Technology	Platinum Enterprise Modeling Suite: Erwin, BPWin, Paradigm Plus	Data, process, and business component modeling
Persistence Inc.	Pwertier	Mapping from O-O to relational model
Rational	Rational Rose	Modeling in UML and application generation in C++ and JAVA
Rogue Ware	RW Metro	Mapping from O-O to relational model
Resolution Ltd.	Xcase	Conceptual modeling up to code maintenance
Sybase	Enterprise Application Suite	Data modeling, business logic modeling
Visio	Visio Enterprise	Data modeling, design and reengineering Visual Basic and Visual C++

ER DIAGRAM FOR A BANK DATABASE

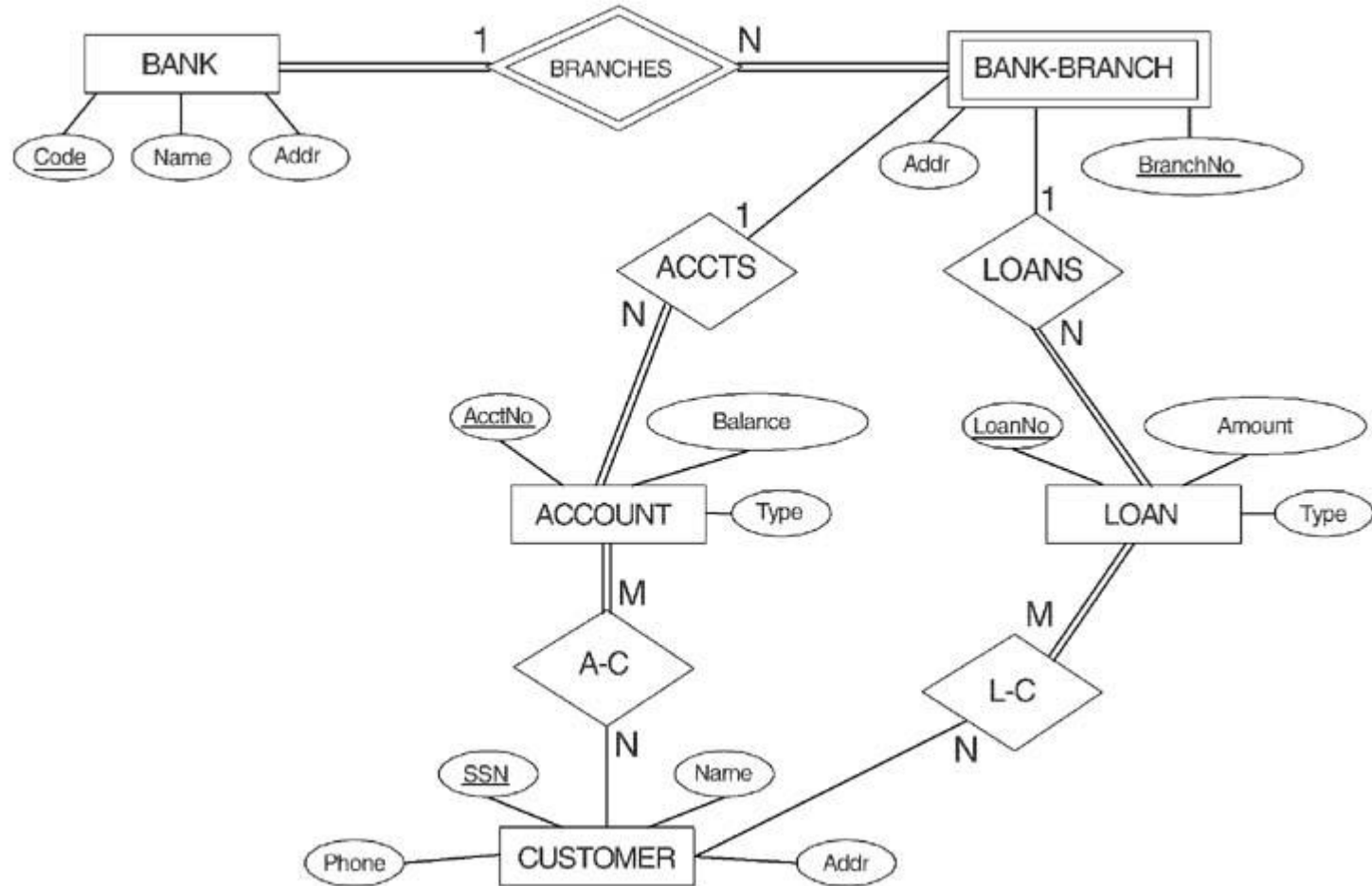

PROBLEM with ER notation

THE ENTITY RELATIONSHIP MODEL IN
ITS ORIGINAL FORM DID NOT
SUPPORT THE SPECIALIZATION/
GENERALIZATION ABSTRACTIONS

Extended Entity-Relationship (EER) Model

- Incorporates Set-subset relationships
- Incorporates Specialization/Generalization Hierarchies

NEXT CHAPTER ILLUSTRATES HOW THE ER
MODEL CAN BE EXTENDED WITH

- Set-subset relationships and
Specialization/Generalization Hierarchies and how to
display them in EER diagrams