

Evaporation

Evaporation

Evaporation refers to the partial removal of water from a liquid food material through vapourisation.

Separation is achieved by exploiting the difference in volatility between water and solutes.

Generally 80% water is removed and 20% is left.

Objectives of evaporation

- To **pre-concentrate foods** prior to drying, freezing or sterilization, and hence to reduce weight and volume.
- To **reduce container size and cost involvement** in storage, transportation, handling and packaging.
- To **save energy** in subsequent operations.
- To **enhance shelf life**.
- To achieve **greater convenience** for consumer (e.g. fruit drinks for dilution, tomato puree, pastes, etc.) or for manufacturers (e.g. lignin, pectin, fruit concentrates for use in ice or baked goods)
- To impart an acceptable **change in flavour and/or colour** of a food (e.g. caramelized syrups for use in baked goods and sugar confectionary).
- Evaporation is used prior to drying to reduce energy cost.

Basic functions of an evaporator

1. Transfer of heat from steam to the food
2. Vapourisation of water
3. Removal of fluid droplets from the vapour before it leaves the evaporator.

Usually

- The **latent heat is transferred** from the heating medium (steam) to the food .
- The pressure in the food section is kept below atmospheric to achieve boiling at less than 100°C.
- The vapour leaving the evaporator is **condensed**.

Basic functions of an evaporator

Thus, the basic parts of the evaporator are:

- Heat exchanger,
- Means of separating vapour produced, and
- Mechanical or steam ejector vacuum pump,
- Condenser (in case the vapour is not used in a subsequent evaporator as heating medium).

Mechanical pumps have lower operating costs, but higher capital costs than steam ejector pumps.

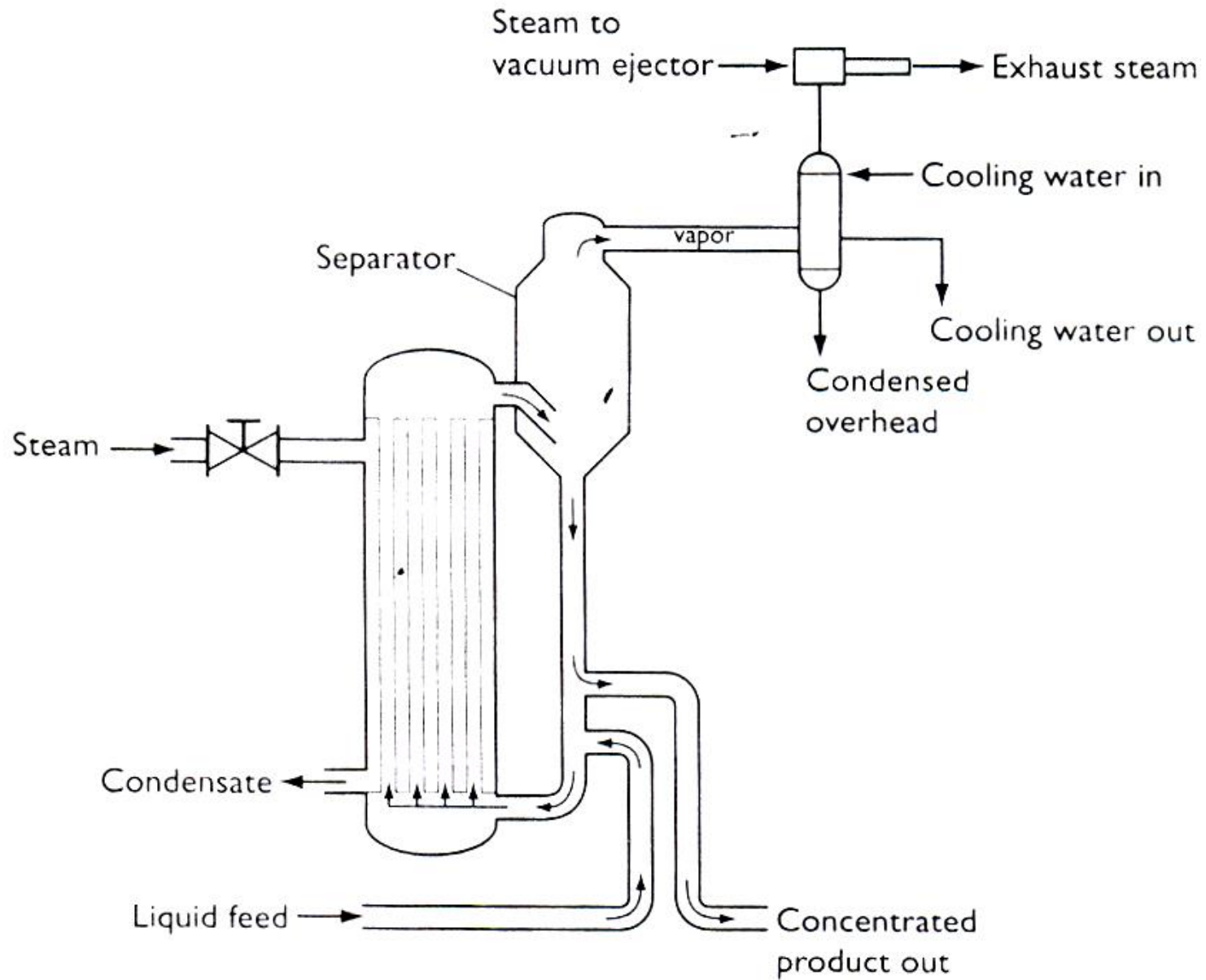

Basic parts of an evaporator

Types of evaporators

Natural circulation types

Open or closed pan evaporators

Short tube (Calandria) evaporators

Long tube vertical evaporator:
Climbing/ Falling film type

Forced circulation types

Mechanical (or agitated) thin film evaporator

Plate evaporator

Expanding flow evaporators

In forced circulation evaporators, a **pump** or **scraper** assembly moves the liquor, usually in thin layers. It gives **higher heat transfer rates** and **short residence times**. It also gives **more compact equipment** and **higher production rates**.

Open kettle evaporator

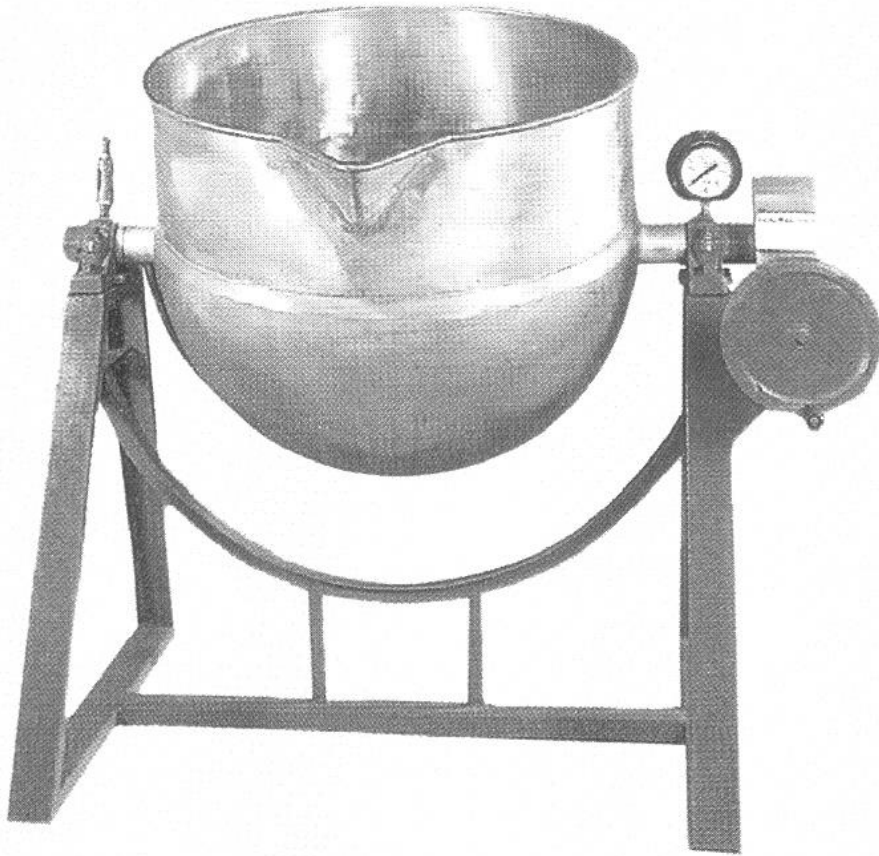

Jacketed open kettle evaporator

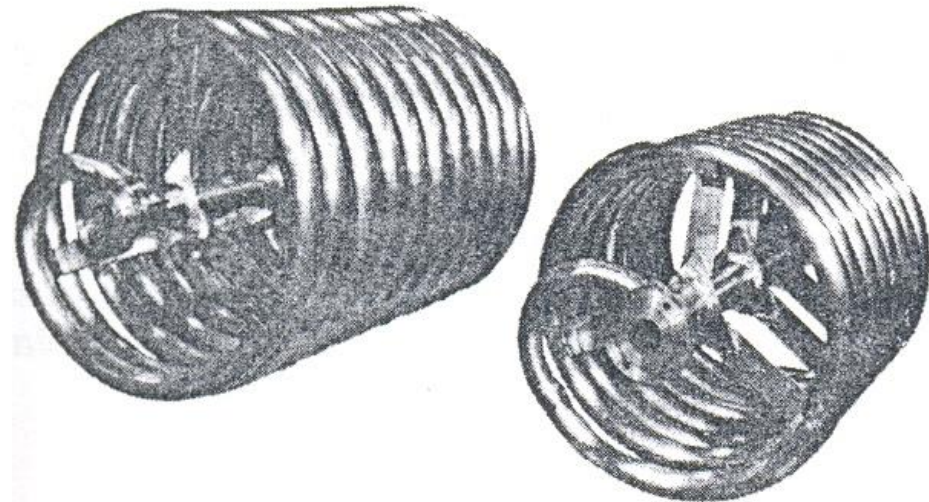

Spiral coils used in open kettle evaporators

Short tube evaporator

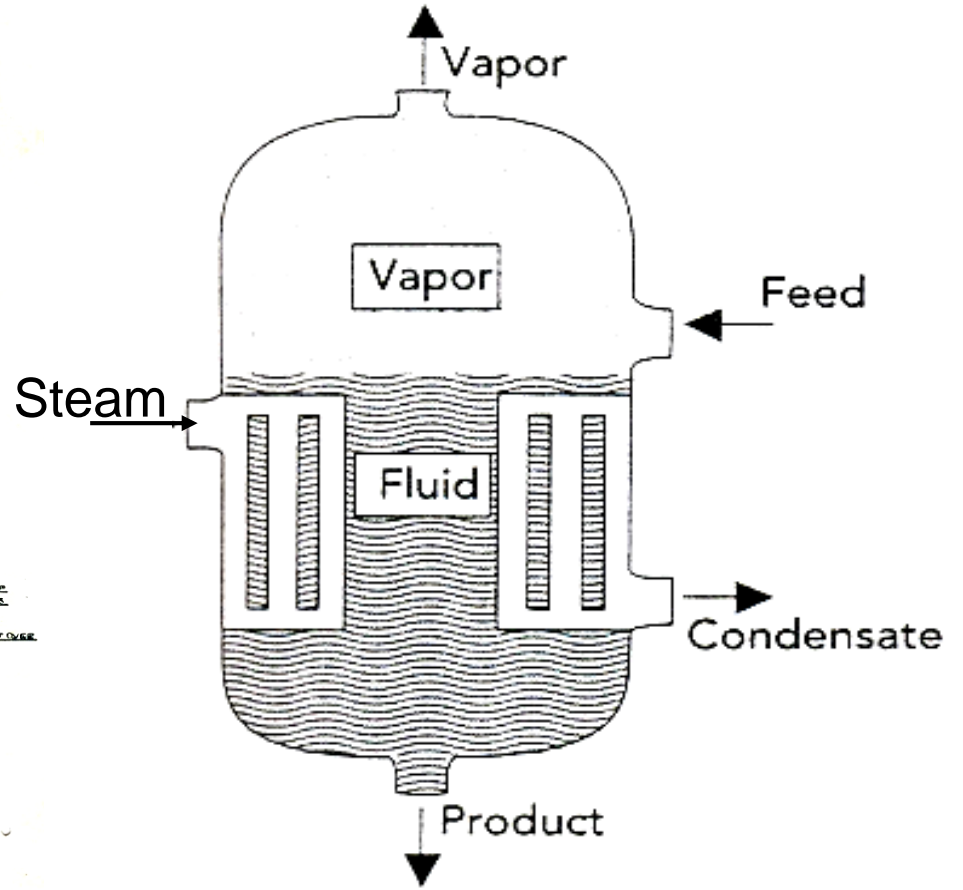
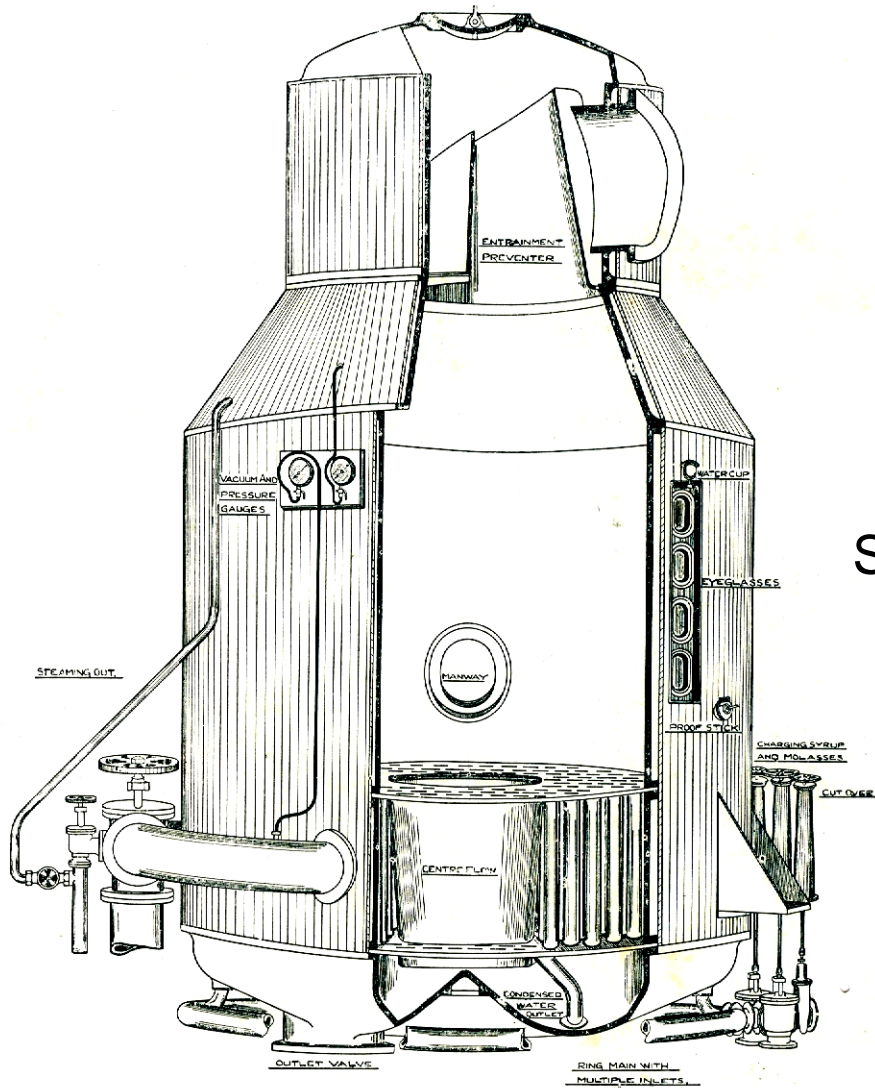

Short tube evaporator

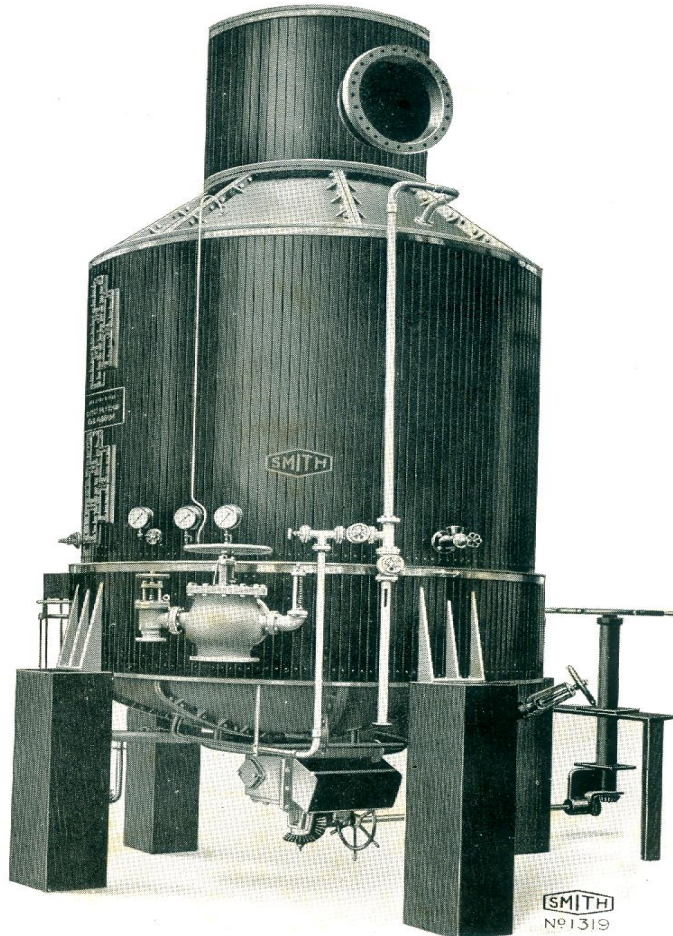

- Shell and tube type HE
- Tube bundles (Vertical/ Horizontal)
- Steam generally in the shell
- Central down-comer large dia tube
- Liquid moves due to vapour pr difference
- Baffles at top
- Steam at atm. pr. or elevated pr (up to 2.8 kg/cm²)
- Single pass / Multi pass
- Basket evaporator
- External calandria evaporator
- Low viscosity products
- Almost obsolete now

Shell and tube type evaporators are also known as calandria

Long tube vertical evaporators

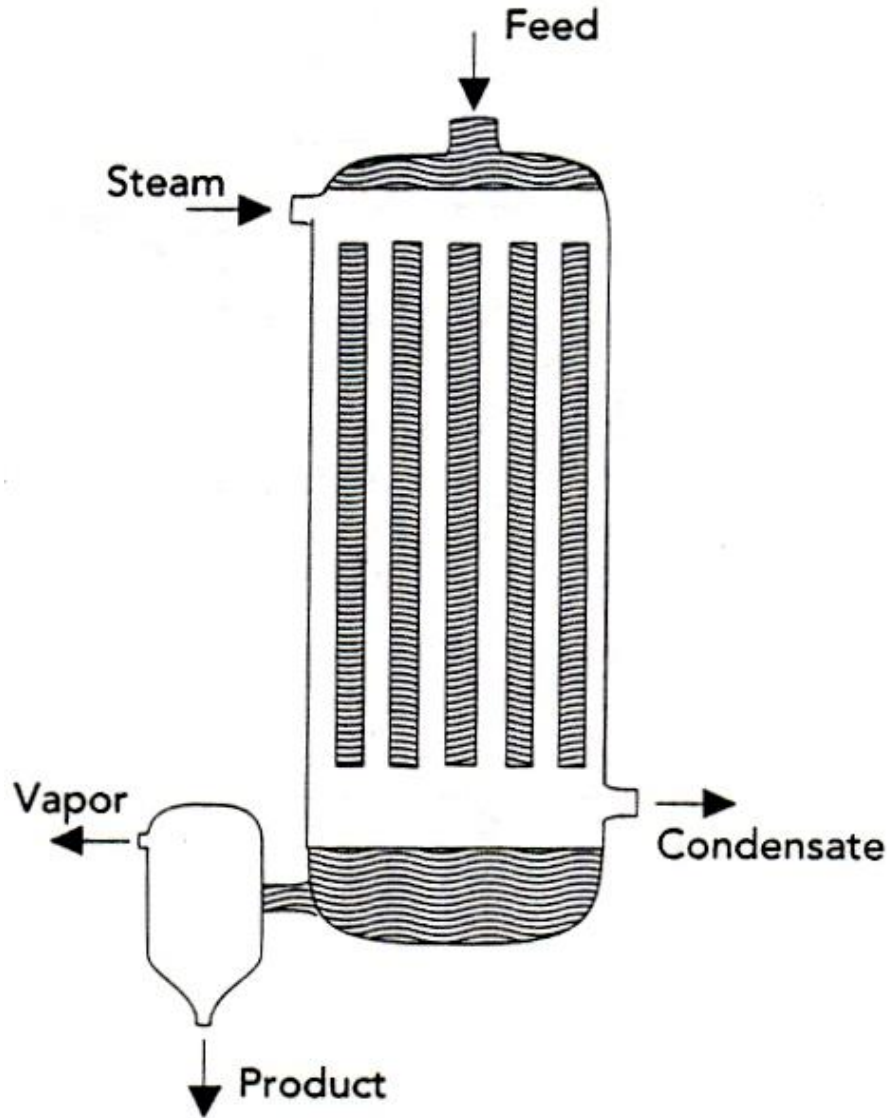

Falling film type

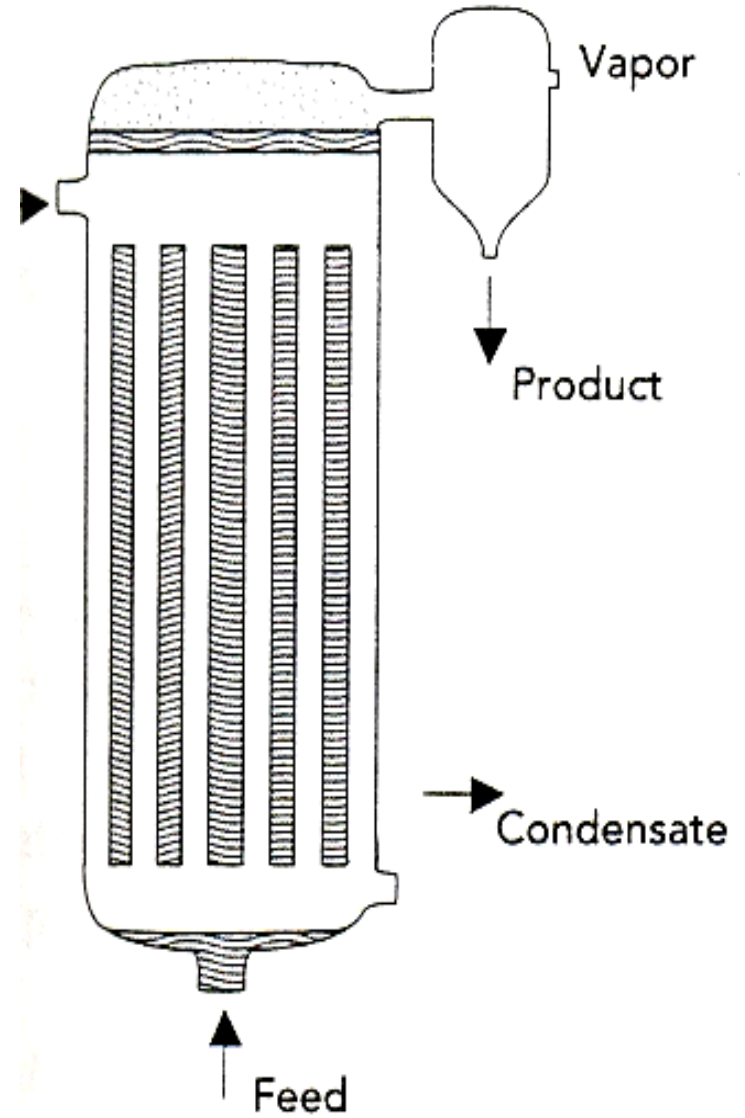

Climbing film type

Long tube vertical evaporators

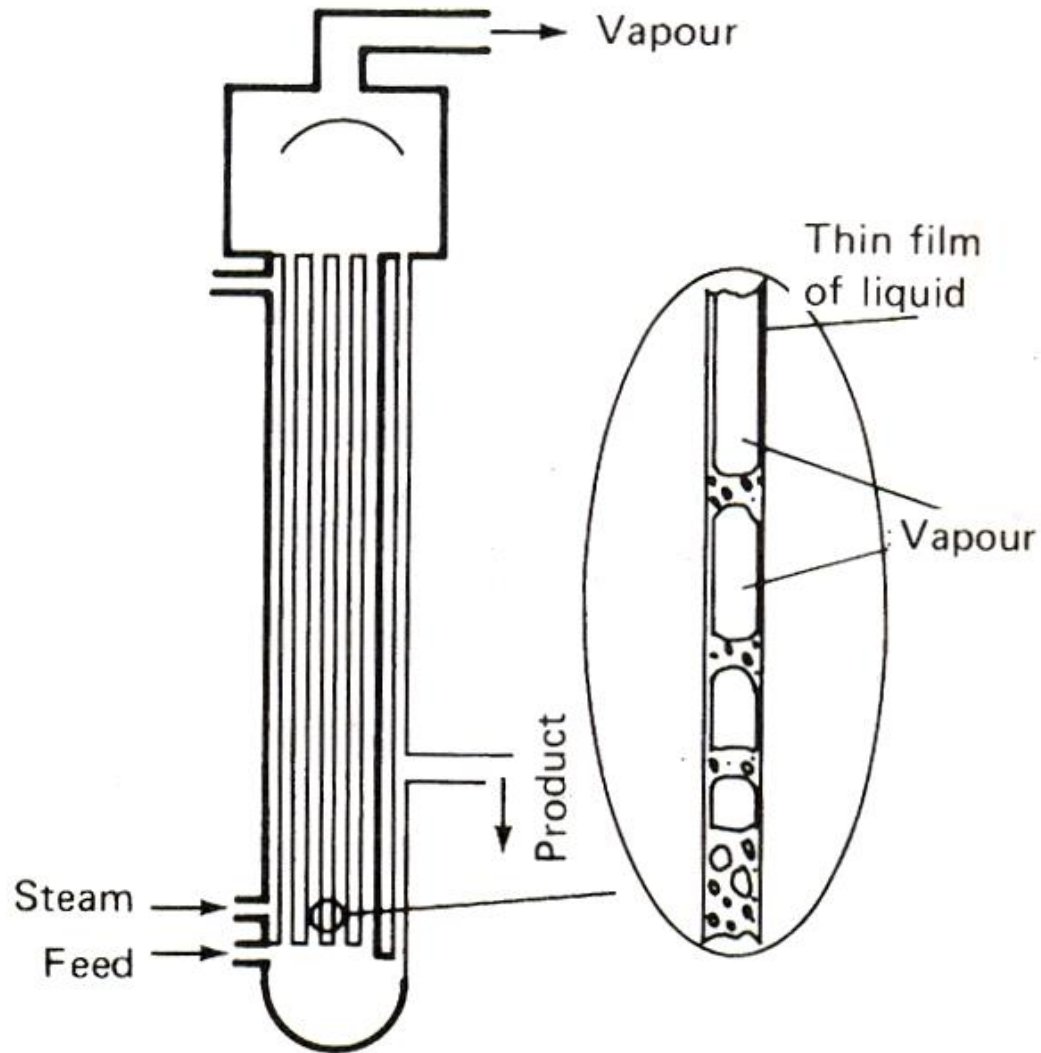

Flow pattern in a Climbing film type evaporator

Long tube evaporator

Shell and tube HE; 3-15 m; Entry air vel: 0.3-1.2 m/s

Rising film type	Falling film type
Tube dia: 5 cm	5-25 cm
Flow by buoyancy	Flow by gravity
Liquid almost heated to boiling point	Distributor at the top
Flow velocity increases in the rising column	Flow velocity at the end 200 m/sec
Return leg for recirculation	Recycling possible
Baffle/ vapour separators at top	Vapour separator at bottom
Low viscosity product: 0.1 Ns/m ² Effective for foaming fluids	More viscous foods, heat sensitive foods
Residence time is 3-4 min	5-30 sec residence time

Forced circulation evaporators

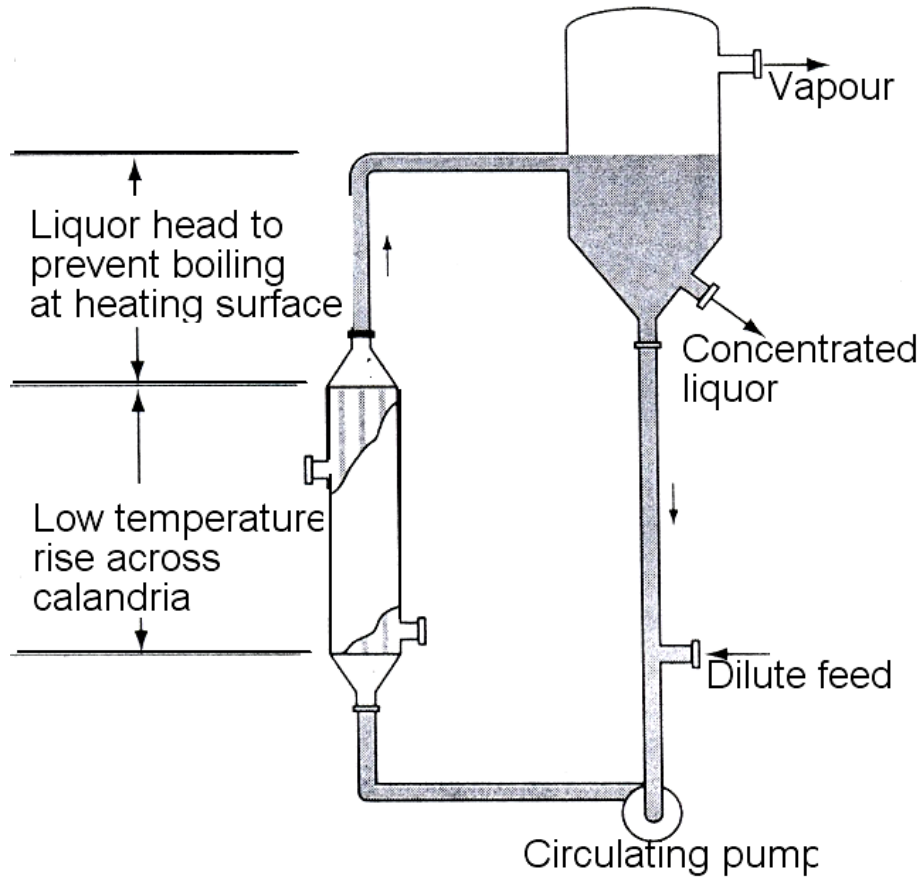

with vertical heat exchanger

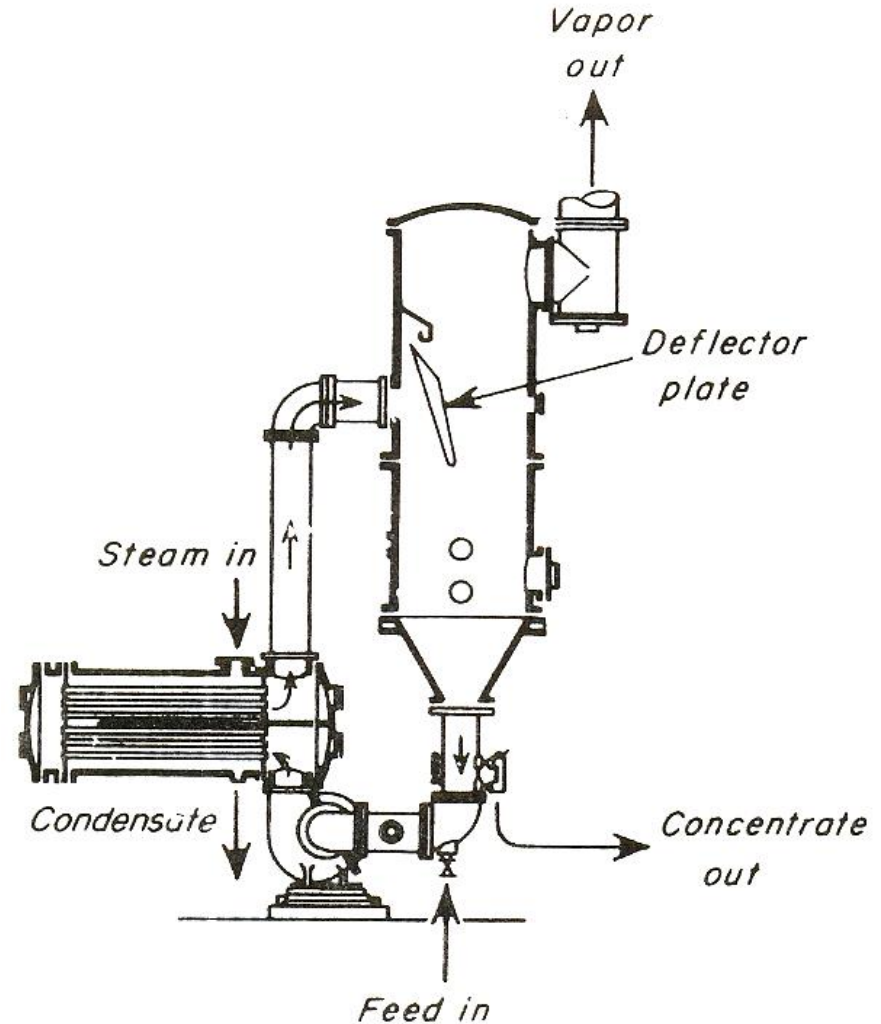

with horizontal tube two-pass heat exchanger

Forced circulation evaporators

- Horizontal or vertical heat exchanger
- Horizontal may have two passes
- Forced at air velocity of 2-5.5 m/s
- **Tubes are under static head so that no boiling in tubes**
- Vapour separator- Deflector plate/ baffle
- Part of liquid is recirculated
- Suitable for viscous foods 20 Ns/m²

Agitated thin film evaporators

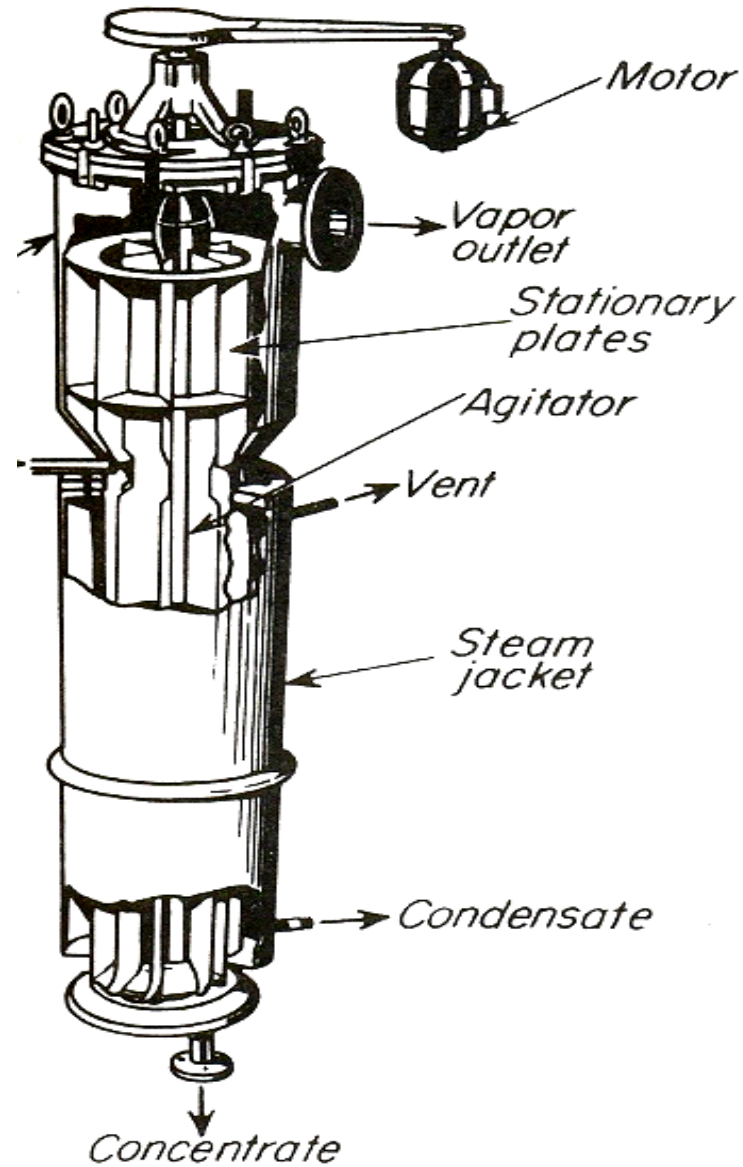

Agitated thin film evaporators

- Steam jacketed vessel
- High speed rotor, fitted with short blades along its length
- Film thickness: 1.25 mm for scraped surface
- 0.25 mm for wiped surface
- Residence time 0.5-100 s
- Extra capital / running cost (due to mechanical agitation, and **more precise alignment**)
- Only single effect is possible
- Up to 20 Ns/m²
- Used mostly for finishing of high viscous products

Agitated thin film evaporators

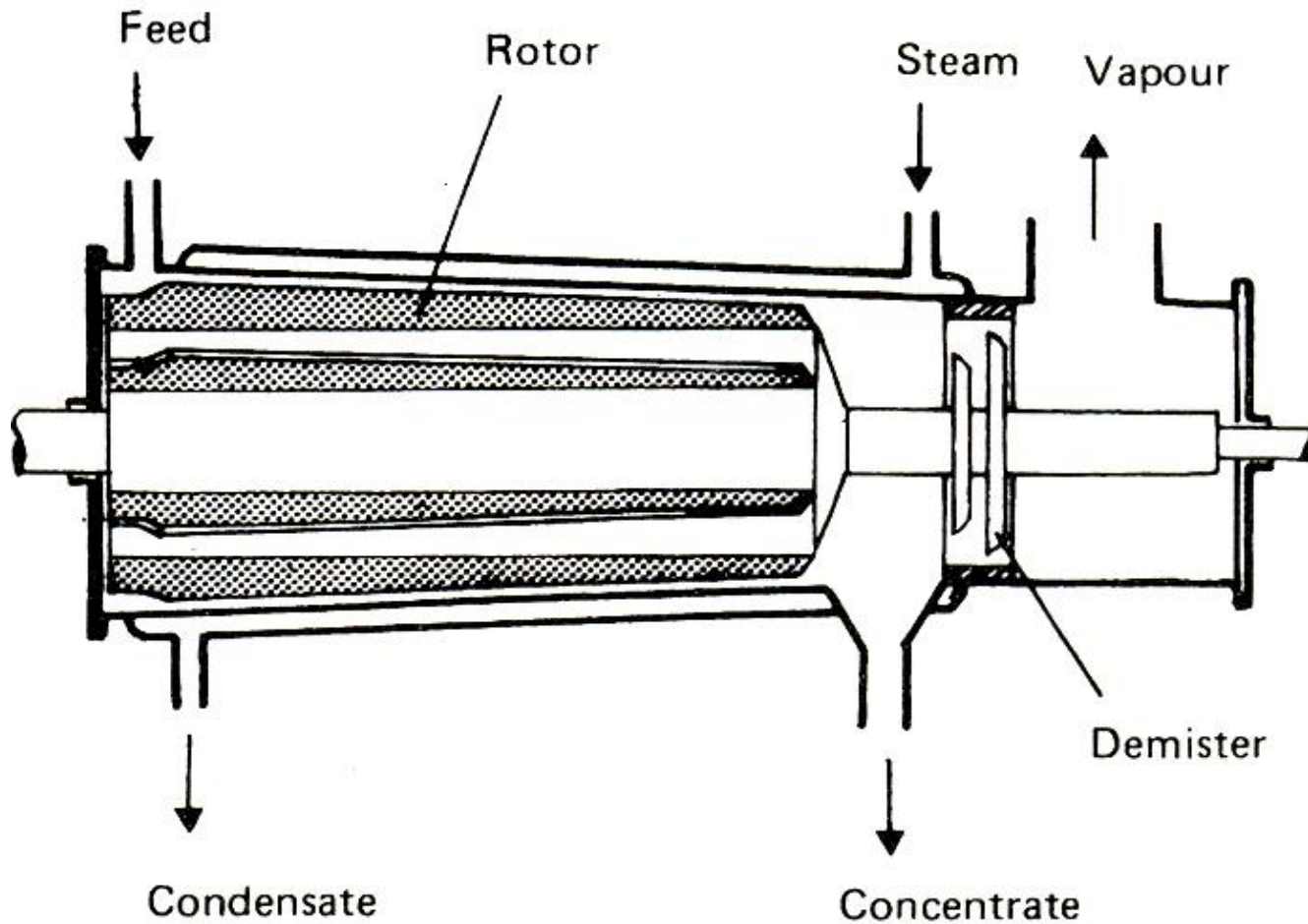

Scraped surface type evaporator

Centri-therm conical evaporator

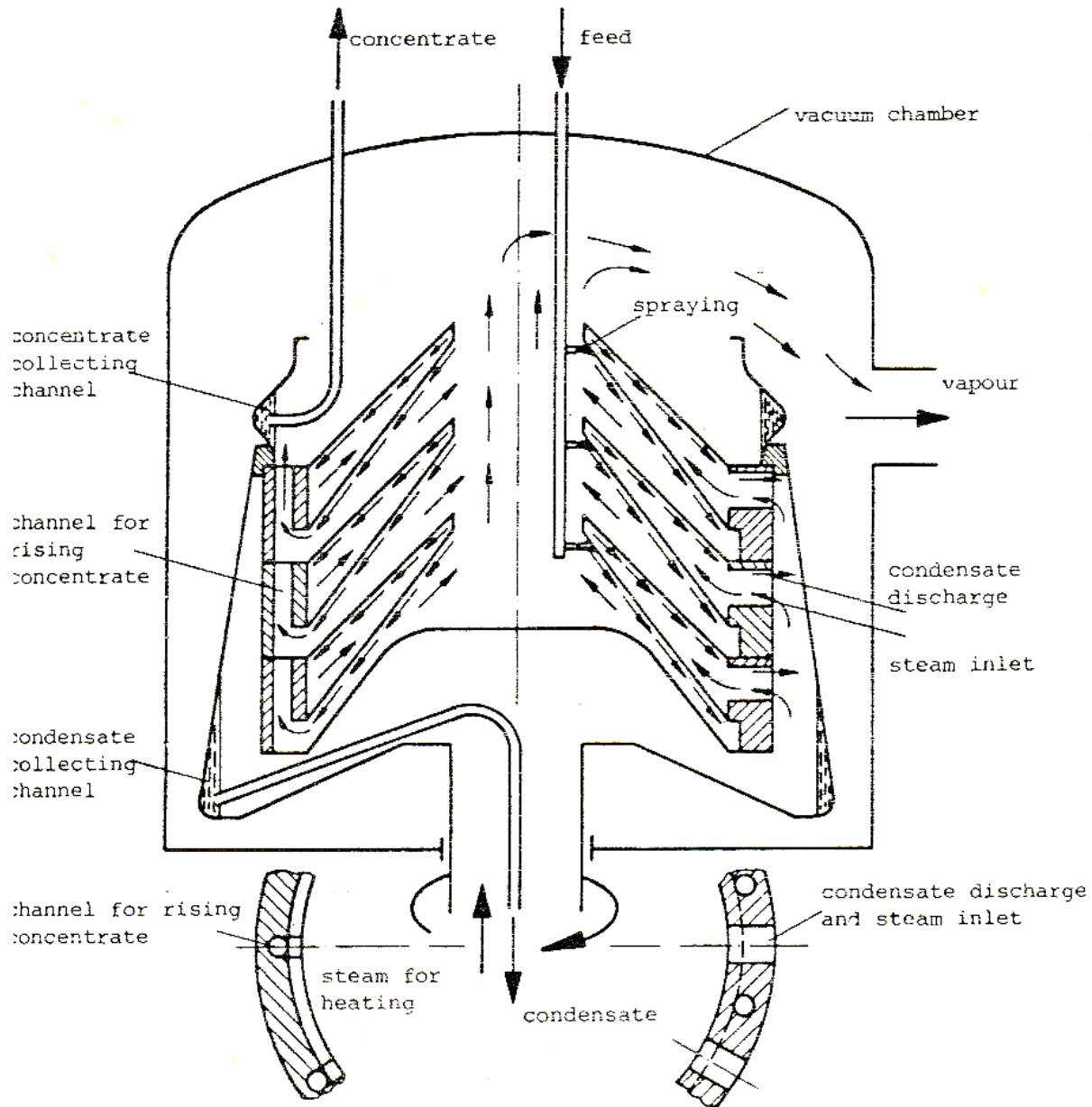

Centri-therm conical evaporator

- Feed from a central pipe to underside of rotating cone
- Liquid moves by centrifugal force
- Film thickness : 0.1 mm
- Residence time : 0.6-1.6 sec
- Condensed steam flung from rotating cones and hence no boundary layer → high heat transfer rate
- High viscous fluid 20 Ns/m²

Plate type evaporator

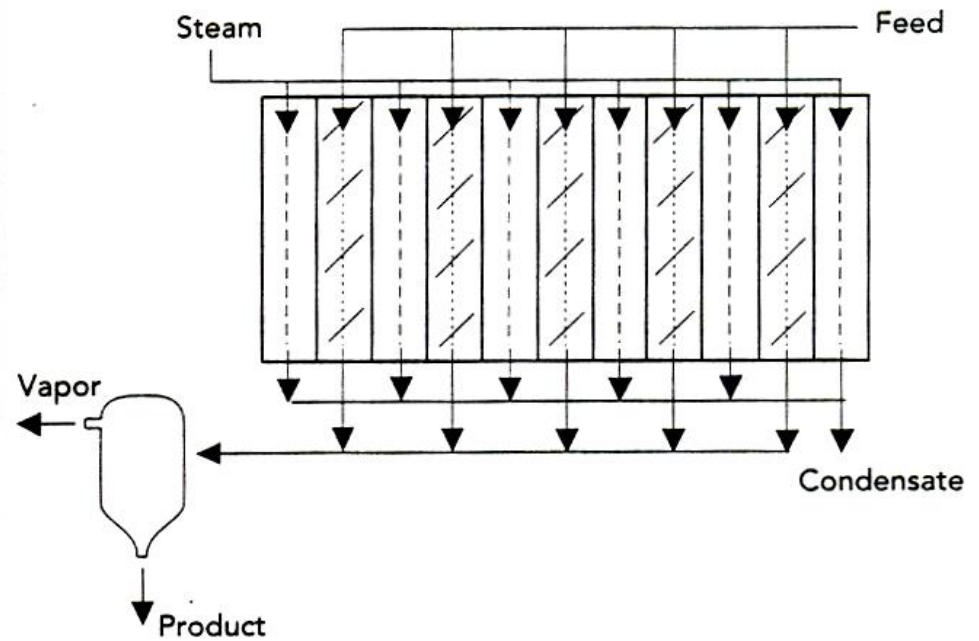
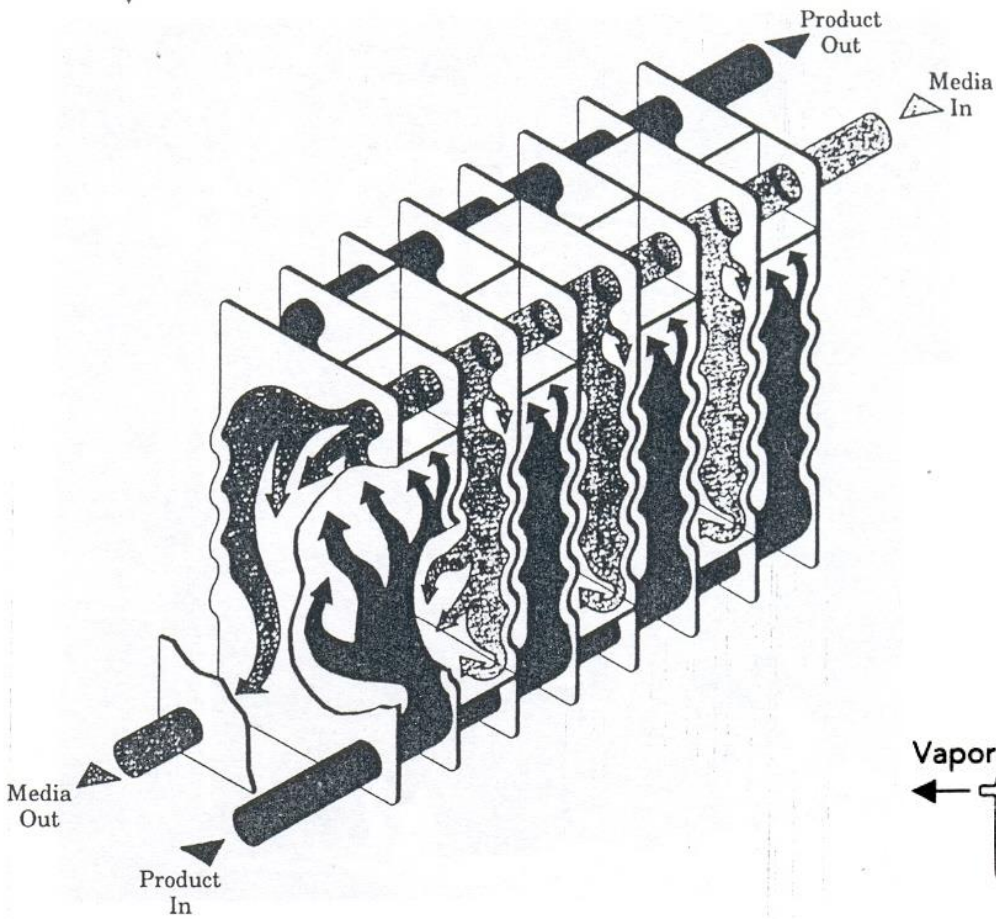

Flow pattern in a Plate type evaporator

Expanding flow evaporators

- Stack of inverted cones
- Steam fed down in alternate channels
- Liquid moves by vapour pressure upward
- Vapour-concentrate mixture leaves tangentially
- Special design of shell, which induces cyclone effect, separates the vapour concentrate mixture
- Reduction of flow area of condensing steam maintains high heat transfer rate

Thank you