

Techniques of Circuit Analysis

Mesh Analysis

Mesh Analysis

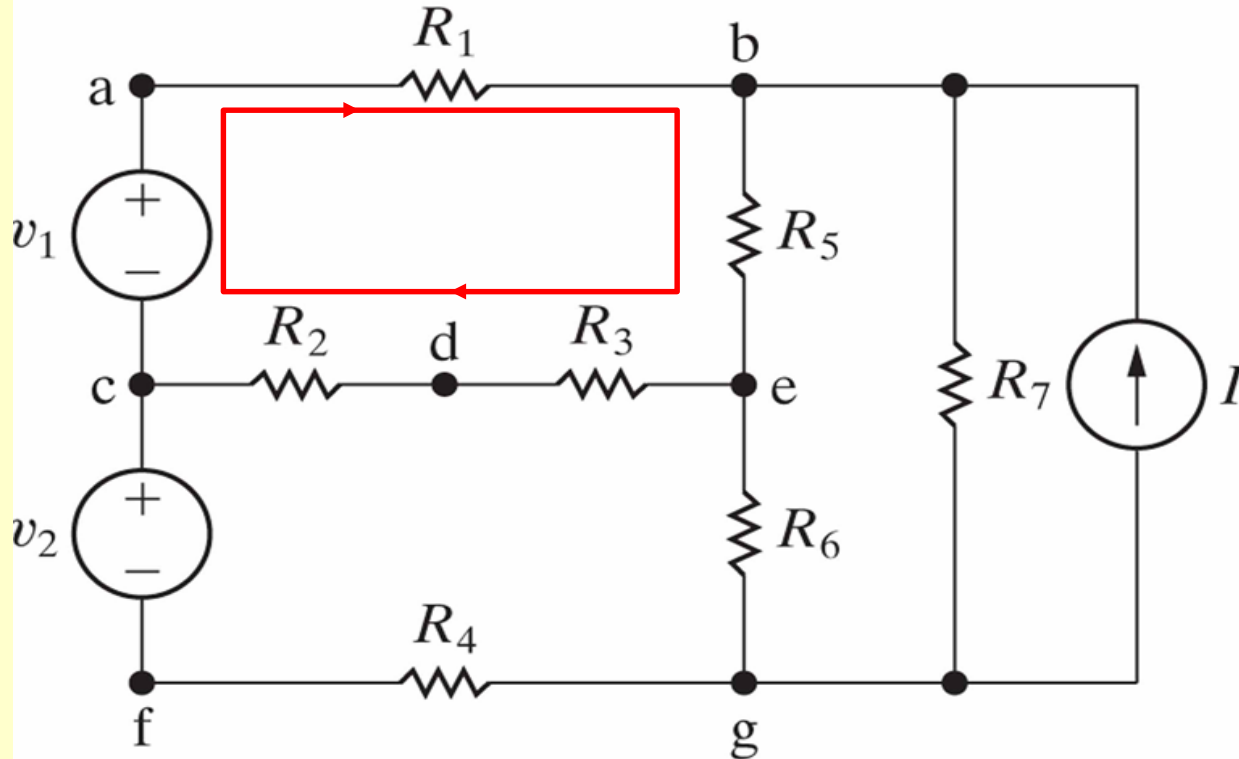

Mesh: a loop that does not enclose any other loops

Mesh Analysis: Basic Concepts:

- In formulating mesh analysis we assign a mesh current to each mesh.

$$i_{R_3} = i_a - i_b$$

$$-v_1 + i_a R_1 + (i_a - i_b) R_3 = 0$$

$$i_b R_2 + v_2 - (i_a - i_b) R_3 = 0$$

$$i_b R_2 + v_2 + (i_b - i_a) R_3 = 0$$

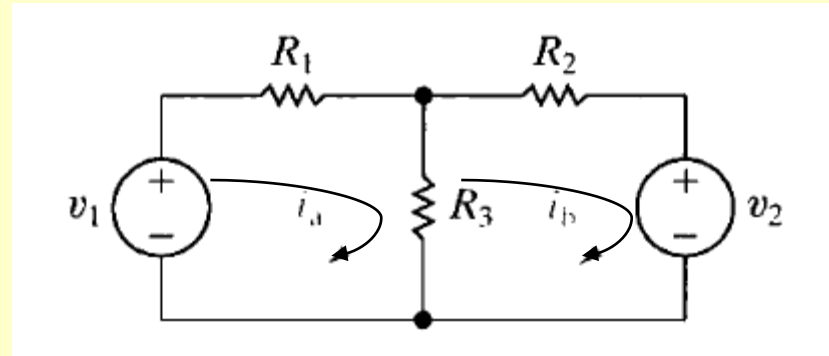

Collecting the coefficients of i_a and i_b

$$v_1 = i_a(R_1 + R_3) - i_b R_3 = 0$$

$$-v_2 = -i_a R_3 + i_b(R_2 + R_3) = 0$$

Problem 4.33:

Use the mesh – current method to find i_a , i_b and i_c

$$-60 + 4i_1 + 10(i_1 - i_2) + 1i_1 = 0$$

$$15i_1 - 10i_2 = 60 \dots\dots\dots (1)$$

$$2i_2 + 20 + 3i_2 + 10(i_2 - i_1) = 0$$

$$-10i_1 + 15i_2 = -20 \dots\dots\dots (2)$$

Solving, $i_1 = 5.6A$, $i_2 = 2.4A$

$$i_a = i_1 = 5.6 \text{ A}$$

$$i_b = i_1 - i_2 = 3.2 \text{ A}$$

$$i_c = -i_2 = -2.4 \text{ A}$$

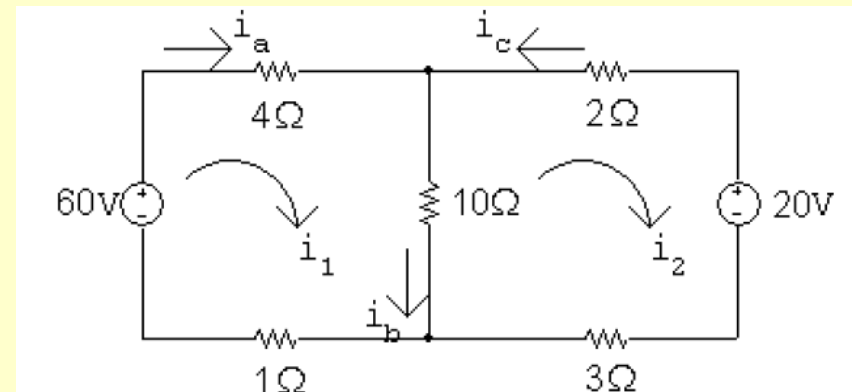
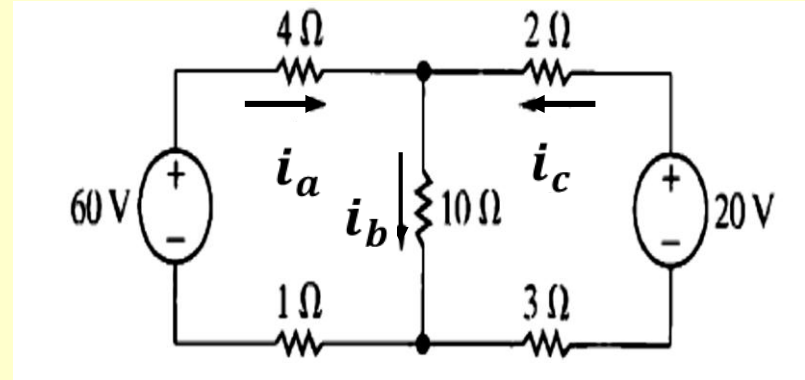

Example 4.4 Using Mesh-Current Method

Use the mesh-current method to determine the power associated with each voltage source in the circuit shown

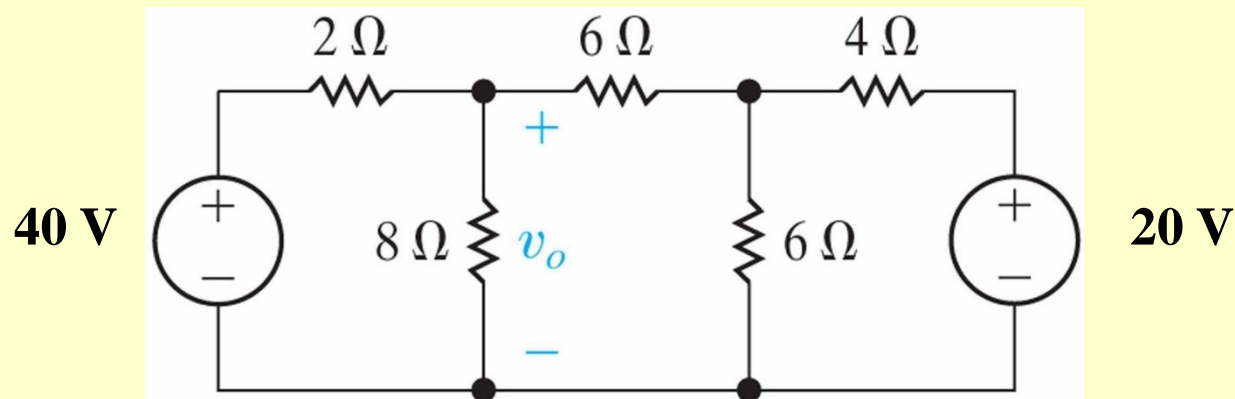

$$-40 + 2i_a + 8(i_a - i_b) = 0$$

$$8(i_b - i_a) + 6i_b + 6(i_b - i_c) = 0$$

$$6(i_c - i_b) + 4i_c + 20 = 0$$

$$-40 + 2i_a + 8(i_a - i_b) = 0$$

$$8(i_b - i_a) + 6i_b + 6(i_b - i_c) = 0$$

$$6(i_c - i_b) + 4i_c + 20 = 0$$

$$10i_a - 8i_b + 0i_c = 40;$$

$$i_a = 5.6 \text{ A,}$$

$$-8i_a + 20i_b - 6i_c = 0;$$

$$i_b = 2.0 \text{ A,}$$

$$0i_a - 6i_b + 10i_c = -20.$$

$$i_c = -0.80 \text{ A.}$$

$$p_{40\text{V}} = -40i_a = -224 \text{ W.} \quad p_{20\text{V}} = 20i_c = -16 \text{ W.}$$

$$v_o = 8(i_a - i_b) = 8(3.6) = 28.8 \text{ V.}$$

Mesh Analysis: Basic Concepts:

✓ ASSESSMENT PROBLEM

Objective 2—Understand and be able to use the mesh-current method

4.7 Use the mesh-current method to find (a) the power delivered by the 80 V source to the circuit shown and (b) the power dissipated in the 8 Ω resistor.

Answer: (a) 400 W;
(b) 50 W.

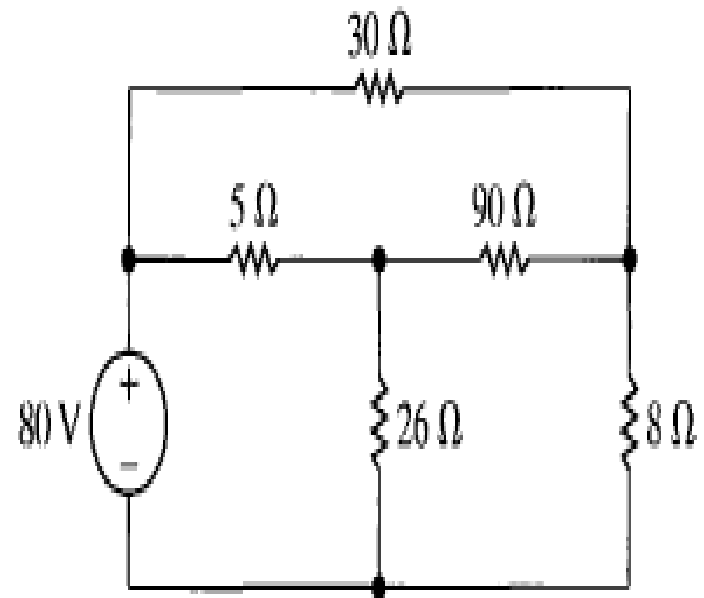

Problem 4.31

Using Mesh-Current method, find all the mesh currents.

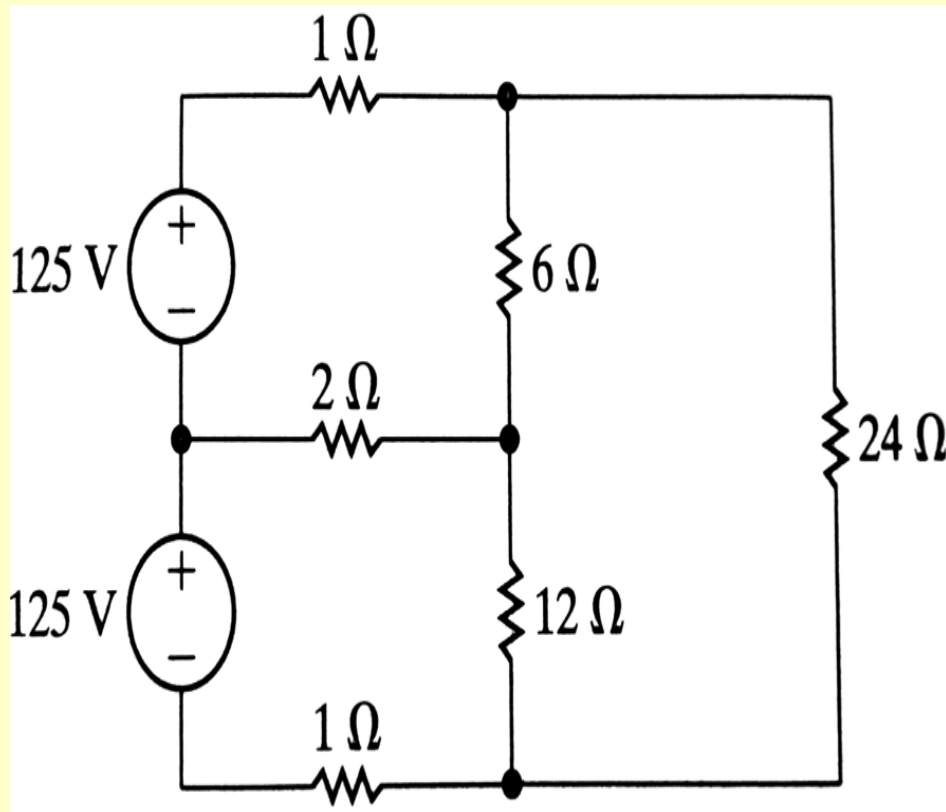

**23.76 A,
18.43 A,
8.66 A**