

PURE BENDING

Theory of simple bending (assumptions)

- ❖ Material of beam is homogenous and isotropic => **constant E in all direction**
- ❖ Young's modulus is constant in compression and tension => **to simplify analysis**
- ❖ Transverse section which are plane before bending before bending remain plain after bending. => **Eliminate effects of strains in other direction**
- ❖ Beam is initially straight and all longitudinal filaments bend in circular arcs => **simplify calculations**
- ❖ Radius of curvature is large compared with dimension of cross sections => **simplify calculations**
- ❖ Each layer of the beam is free to expand or contract => **Otherwise they will generate additional internal stresses**

Bending in beams

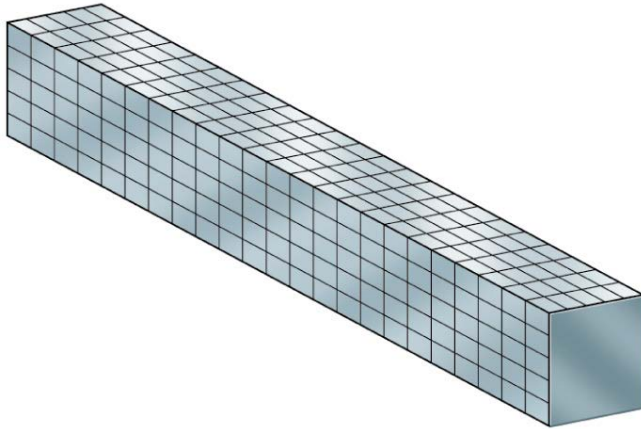

Before deformation

(a)

Copyright © 2005 Pearson Prentice Hall, Inc.

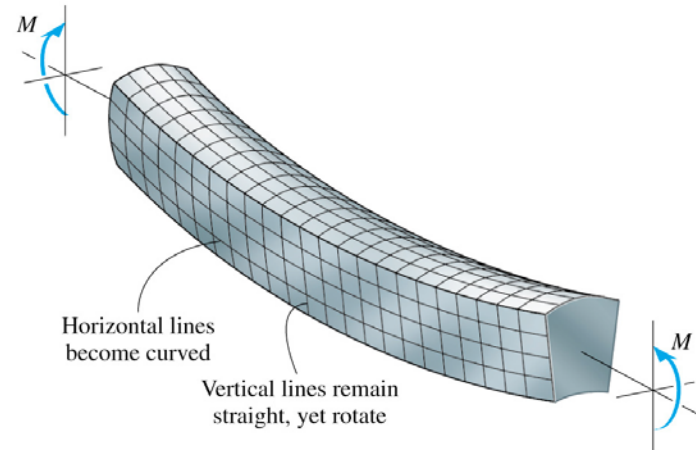

After deformation

(b)

Copyright © 2005 Pearson Prentice Hall, Inc.

Key Points:

1. Internal bending moment causes beam to deform.
2. For this case, top fibers in compression, bottom in tension.

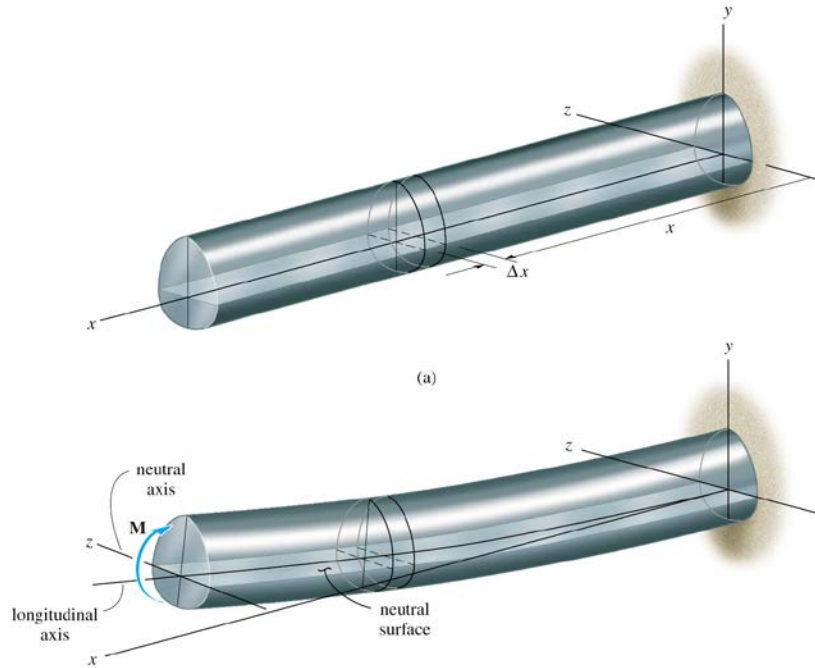

(b)

Copyright © 2005 Pearson Prentice Hall, Inc.

Key Points:

1. Neutral surface – no change in length.
2. Neutral Axis – Line of intersection of neutral surface with the transverse section.
3. All cross-sections remain plane and perpendicular to longitudinal axis.

Deformations In A Symmetric Member In Pure Bending

We will analyze the deformations of a prismatic member possessing a plane of symmetry and subjected at its ends to equal and opposite couples M and M' acting in the plane of symmetry. The member will bend under the action of the couples, but will remain symmetric w.r.t that plane. (Fig. 4.7)

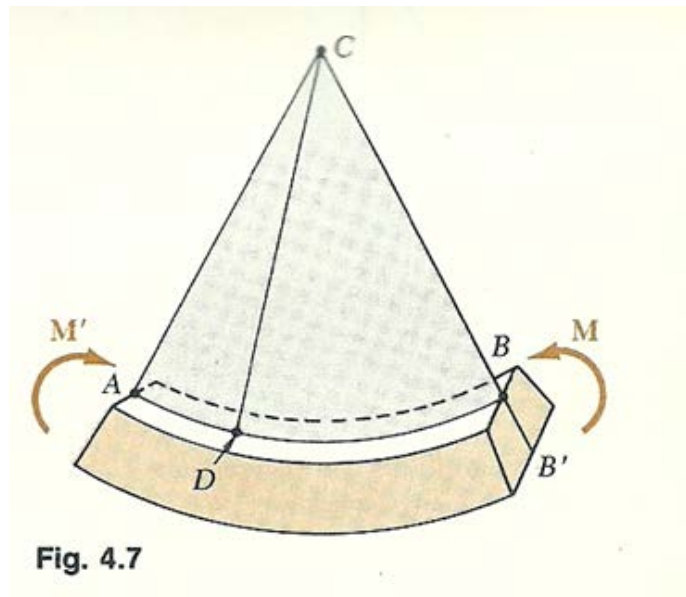

Bending moment (M) is the same in any cross-section, the member will bend uniformly. The line AB along with the upper face of the member intersects the plane of the couples will have a constant ~~to~~ curvature. The line AB , which was originally a straight line, will be transformed into a circle of center C , and so will the line $A'B'$ along which the lower face of the member intersects the plane of symmetry. \odot The line AB will decrease in length when the member is bent, that's when $M > 0$, while $A'B'$ will become longer.

We will prove that any cross section perpendicular to the axis of the member remains plane, the plane of the section passes through C . If this were not the case we could find a point E of the original section through D (Fig. 4.8) after the member has been bent would not lie in the plane perpendicular to the plane of symmetry which contains line CD . (Fig. 4.8 b)

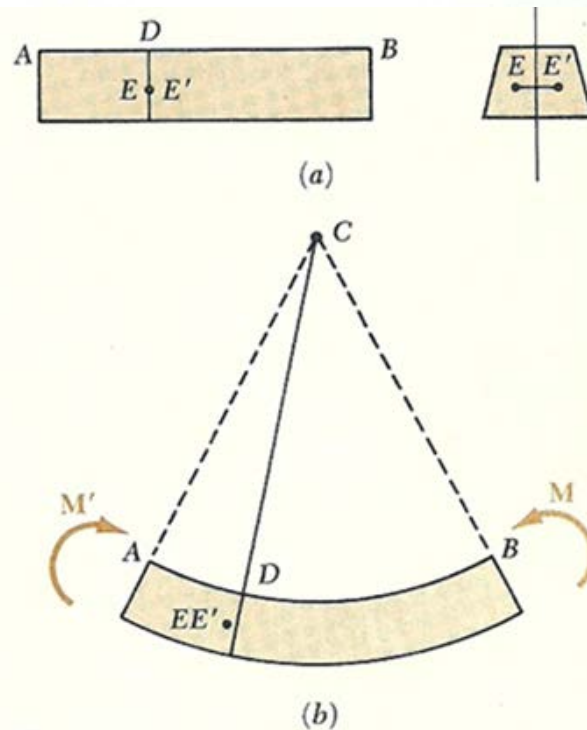

Fig. 4.8

Since the bending moment M is the same throughout the member and the points corresponding to E and E' would also move to the left.

An observer at A would conclude that the loading causes the points E and E' in the various cross-sections to move toward him.

But an observer at B , to whom the loading looks the same, and who observes the points E and E' in the ^{same positions} ~~various cross~~ sections would reach the opposite conclusion.

This inconsistency leads us to conclude that E and E' will lie in the plane defined by CD and therefore, the section remains plane and passes through C .

There must exist a surface parallel to the upper and lower faces of the member where ϵ_x and $\sigma_x = 0$. This surface is called the neutral surface. The neutral surface intersects the plane of symmetry along an arc of circle DE (Fig. 4.10) and it intersects a transverse section along a straight line called the neutral axis of the section.

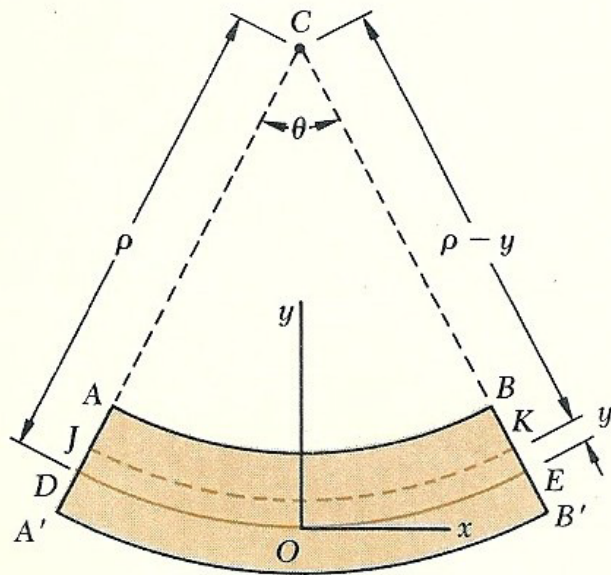

(a) Longitudinal, vertical section
(plane of symmetry)

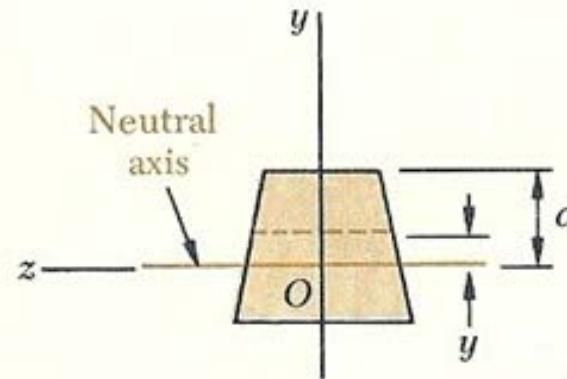

(b) Transverse section

Fig. 4.10

the longitudinal strain ϵ_x in the elements of JK;

$$\epsilon_x = \frac{\delta}{L} = \frac{-y\theta}{\rho\theta} = -\frac{y}{\rho}$$

longitudinal normal strain ϵ_x varies linearly throughout the member with the distance y from the neutral surface.

The strain ϵ_x is maximum when y is largest.
 c is the largest distance from the neutral surface.

$$\epsilon_m = \frac{c}{\rho} \quad \text{max absolute value of the strain}$$

$$\epsilon_x = -\frac{y}{c} \epsilon_m$$

we are still unable to compute the strain or stress at a given point of the member since we have not ^{yet} located the neutral surface in the member.

Stresses And Deformations In The Elastic Range

When the bending moment M is such that the normal stresses in the member remain below the yield strength σ_y . This means that, the stress in the member will remain below the proportional limit and the elastic limit as well. There will be no permanent deformation and Hooke's law for uniaxial stress applies.

Material is assumed to be homogeneous, E is modulus of elasticity, we have in the longitudinal x -direction, $\sigma_x = E \epsilon_x$

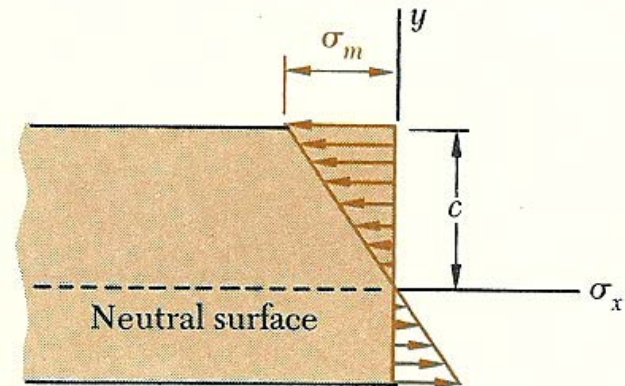

Fig. 4.11

$$\sigma_x = -\frac{y}{c} \sigma_m$$

$$\sigma_m = \frac{Mc}{I}$$

Second Moments of Areas

■ Moment of Inertia

- There are many important topics in engineering practice that require evaluation of an integral of the *second moment of area* or *moment of inertia* of the type

$$\int x^2 dA \quad (21)$$

- Consider an area A located in the xy plane as shown in the figure.

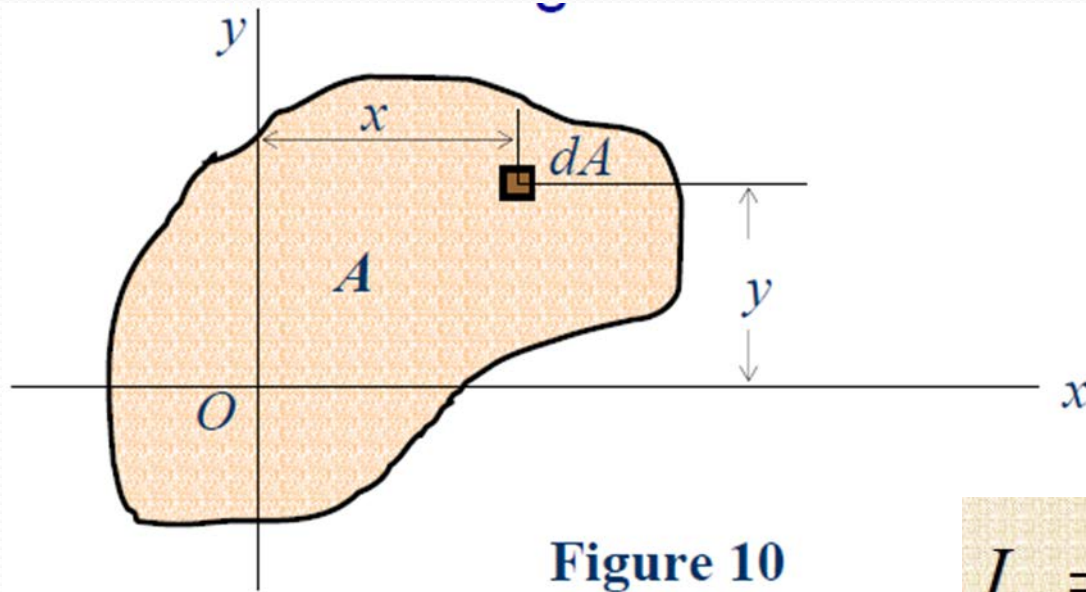

Figure 10

$$I_x = \int_A y^2 dA \quad (22a)$$

$$I_y = \int_A x^2 dA \quad (22b)$$

- The quantities I_x and I_y are referred to as *rectangular moments of inertia*, since they are computed from the rectangular coordinates of the element dA .
- While each integral is basically a double integral, it is possible in many applications to select elements of area dA in the shape of thin horizontal or vertical strips.

■ Polar Moment of Inertia

- The second moment, or polar moment of inertia of an area with respect to an axis perpendicular to the plane of the area is denoted by the symbol J .

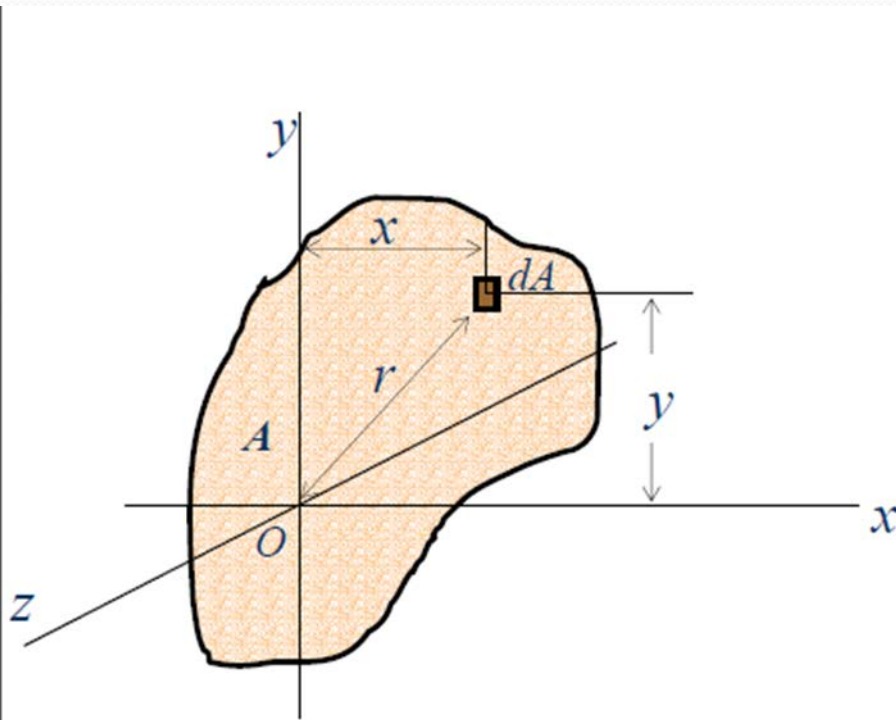

Figure 11

■ Polar Moment of Inertia

$$\begin{aligned} J_z &= \int_A r^2 dA \\ &= \int_A (x^2 + y^2) dA \\ &= \int_A x^2 dA + \int_A y^2 dA \\ &= I_x + I_y \quad (23) \end{aligned}$$

■ Radius of Gyration of an Area

- The radius of gyration of planar area has units of length and is a quantity often used for the design of columns in structural mechanics.
- Provided the areas and moments of inertia are known, the radii of gyration are determined from the following formulas:

$$k_x = \sqrt{\frac{I_x}{A}} \quad (26a)$$

$$k_y = \sqrt{\frac{I_y}{A}} \quad (26b)$$

$$k_z = \sqrt{\frac{I_z}{A}} \quad (26c)$$

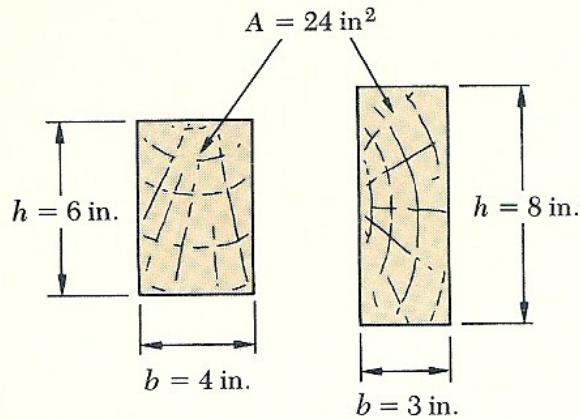

Fig. 4.12

S as practicable. For example, in the case of a wooden beam with a rectangular cross section of width b and depth h , we have

$$S = \frac{I}{c} = \frac{\frac{1}{12}bh^3}{h/2} = \frac{1}{6}bh^2 = \frac{1}{6}Ah \quad (4.19)$$

where A is the cross-sectional area of the beam. This shows that, of two beams with the same cross-sectional area A (Fig. 4.12), the beam with the larger depth h will have the larger section modulus and, thus, will be the more effective in resisting bending.†

In the case of structural steel, American standard beams (S-beams) and wide-flange beams (W-beams) are preferred to other shapes because a large portion of their cross section is located far from the neutral axis (Fig. 4.13).

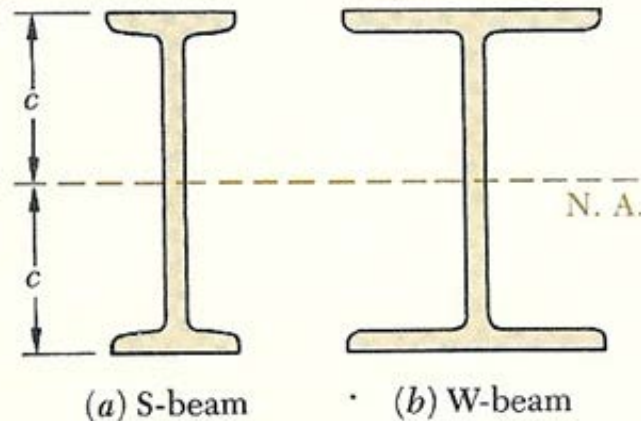

Fig. 4.13

The deformation of the member caused by the bending moment M is measured by the *curvature* of the neutral surface. The curvature is defined as the reciprocal of the radius of curvature ρ , and may be obtained by solving Eq. (4.9) for $1/\rho$:

$$\frac{1}{\rho} = \frac{\epsilon_m}{c} \quad (4.20)$$

But, in the elastic range, we have $\varepsilon_m = \sigma_m/E$. Substituting for ε_m into (4.20), and recalling (4.15), we write

$$\frac{1}{\rho} = \frac{\sigma_m}{Ec} = \frac{1}{Ec} \frac{Mc}{I}$$

or

$$\frac{1}{\rho} = \frac{M}{EI} \quad (4.21)$$

Example 4.01

A steel bar of 20×60 -mm rectangular cross section is subjected to two equal and opposite couples acting in the vertical plane of symmetry of the bar (Fig. 4.14). Determine the value of the bending moment M which causes the bar to yield. Assume $\sigma_Y = 250$ MPa.

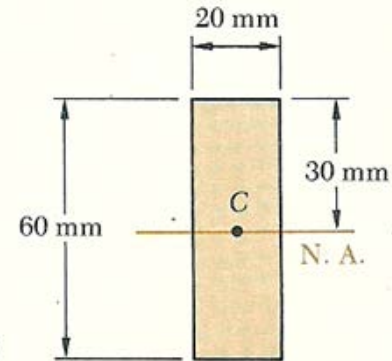

Since the neutral axis must pass through the centroid C of the cross section, we have $c = 30$ mm $= 30 \times 10^{-3}$ m (Fig. 4.15). On the other hand, the centroidal moment of inertia of the rectangular cross section is

$$I = \frac{1}{12}bh^3 = \frac{1}{12}(20 \times 10^{-3} \text{ m})(60 \times 10^{-3} \text{ m})^3 = 360 \times 10^{-9} \text{ m}^4$$

$$M = \frac{I}{c} \sigma_m = \frac{360 \times 10^{-9} \text{ m}^4}{30 \times 10^{-3} \text{ m}} (250 \times 10^6 \text{ N/m}^2)$$

$$M = 3000 \text{ N} \cdot \text{m} = 3 \text{ kN} \cdot \text{m}$$

Example 4.02

An aluminum rod with a semicircular cross section of radius $r = 12$ mm (Fig. 4.16) is bent into the shape of a circular arc of mean radius $\rho = 2.5$ m. Knowing that the flat face of the rod is turned toward the center of curvature of the arc, determine the maximum tensile and compressive stress in the rod. Use $E_a = 70$ GPa.

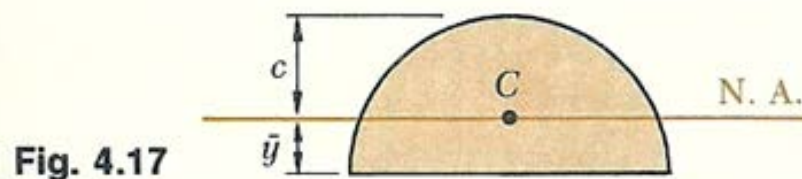
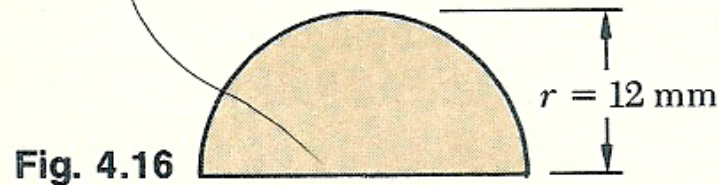

The ordinate \bar{y} of the centroid C of the semicircular cross section is

$$\bar{y} = \frac{4r}{3\pi} = \frac{4(12 \text{ mm})}{3\pi} = 5.09 \text{ mm}$$

The neutral axis passes through C (Fig. 4.17) and the distance c to the point of the cross section farthest away from the neutral axis is

$$c = r - \bar{y} = 12 \text{ mm} - 5.09 \text{ mm} = 6.91 \text{ mm}$$

$$\epsilon_m = \frac{c}{\rho} = \frac{6.91 \times 10^{-3} \text{ m}}{2.5 \text{ m}} = 2.76 \times 10^{-3}$$

and, applying Hooke's law,

$$\sigma_m = E\epsilon_m = (70 \times 10^9 \text{ Pa})(2.76 \times 10^{-3}) = 193.2 \text{ MPa}$$

Since this side of the rod faces away from the center of curvature, the stress obtained is a tensile stress. The maximum compressive stress occurs on the flat side of the rod. Using the fact that the stress is proportional to the distance from the neutral axis, we write

$$\sigma_{\text{comp}} = -\frac{\bar{y}}{c}\sigma_m = -\frac{5.09 \text{ mm}}{6.91 \text{ mm}}(193.2 \text{ MPa}) = -142.3 \text{ MPa}$$

Properties of American Standard Shapes

Appendix C. Properties of Rolled-Steel Shapes (SI Units)

S Shapes (American Standard Shapes)

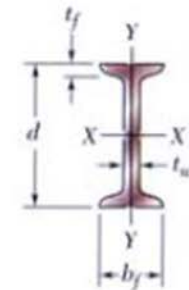

755

Designation†	Area A , mm ²	Depth d , mm	Flange		Web Thick- ness t_w , mm	Axis X-X			Axis Y-Y		
			Width b_f , mm	Thick- ness t_f , mm		I_x 10 ⁶ mm ⁴	S_x 10 ³ mm ³	r_x mm	I_y 10 ⁶ mm ⁴	S_y 10 ³ mm ³	r_y mm
S610 × 180	22900	622	204	27.7	20.3	1320	4240	240	34.9	341	39.0
158	20100	622	200	27.7	15.7	1230	3950	247	32.5	321	39.9
149	19000	610	184	22.1	18.9	995	3260	229	20.2	215	32.3
134	17100	610	181	22.1	15.9	938	3080	234	19.0	206	33.0
119	15200	610	178	22.1	12.7	878	2880	240	17.9	198	34.0
S510 × 143	18200	516	183	23.4	20.3	700	2710	196	21.3	228	33.9
128	16400	516	179	23.4	16.8	658	2550	200	19.7	216	34.4
112	14200	508	162	20.2	16.1	530	2090	193	12.6	152	29.5
98.3	12500	508	159	20.2	12.8	495	1950	199	11.8	145	30.4
S460 × 104	13300	457	159	17.6	18.1	385	1685	170	10.4	127	27.5
81.4	10400	457	152	17.6	11.7	333	1460	179	8.83	113	28.8
S380 × 74	9500	381	143	15.6	14.0	201	1060	145	6.65	90.8	26.1
64	8150	381	140	15.8	10.4	185	971	151	6.15	85.7	27.1

Commonly Used Second Moments of Plane Areas

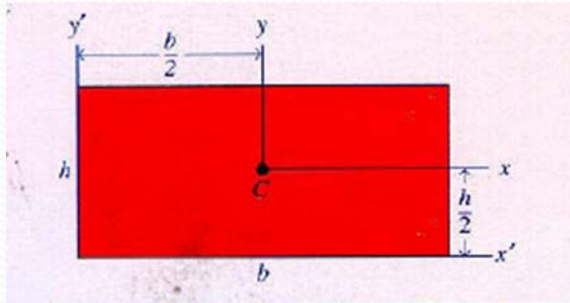

$$I_x = \frac{bh^3}{12}$$

$$I_{x'} = \frac{bh^3}{3}$$

$$A = bh$$

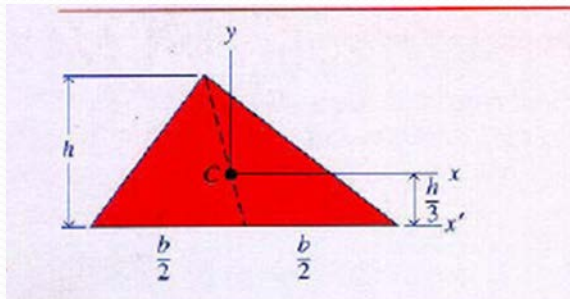

$$I_x = \frac{bh^3}{36}$$

$$I_{x'} = \frac{bh^3}{12}$$

$$A = \frac{1}{2}bh$$

■ Parallel Axis Theorem

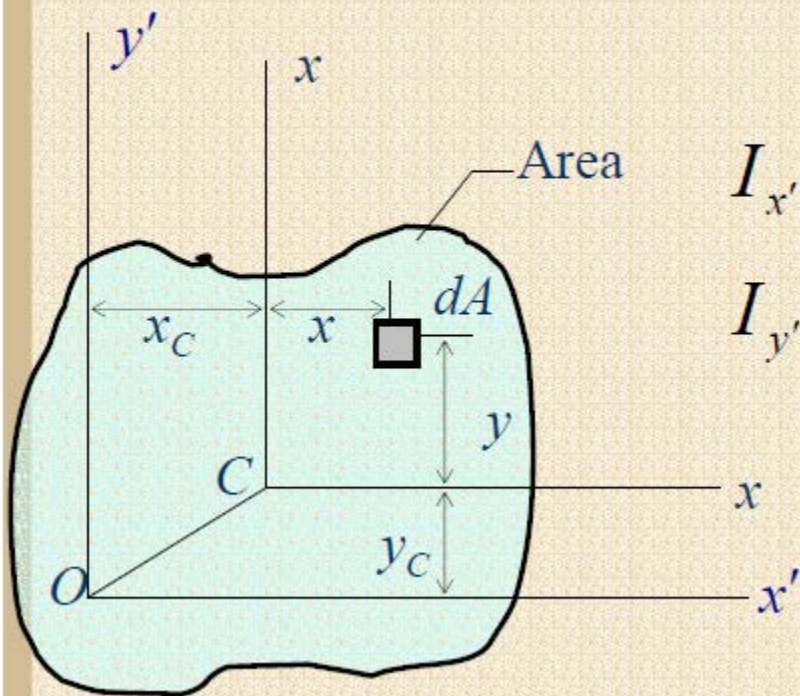

$$I_{x'} = I_{x_c} + y_c^2 A \quad (27)$$

$$I_{y'} = I_{y_c} + x_c^2 A$$

■ Example 3

- Determine the maximum flexural stress produced by a resisting moment M_r of +5000 ft·lb if the beam has the cross section shown in the figure.

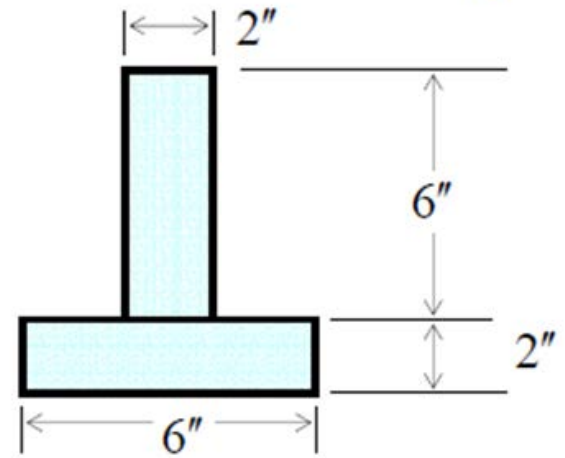

First, we need to locate the neutral axis from the bottom edge:

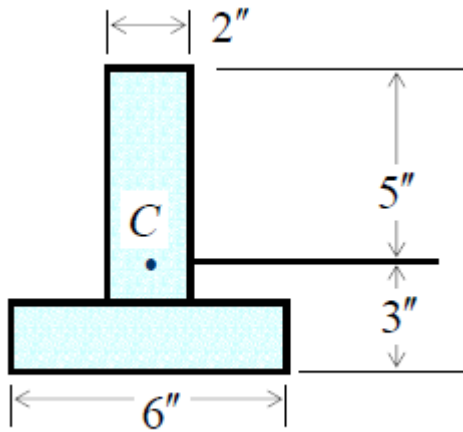

$$y_c = \frac{(1)(2 \times 6) + (2+3)(2 \times 6)}{2 \times 6 + 2 \times 6} = \frac{72}{24} = 3''$$

$$y_{\text{ten}} = 3'' \quad y_{\text{com}} = 6 + 2 - 3 = 5'' = y_{\text{max}}$$

$$\text{Max. Stress} = \frac{M_r y_{\text{max}}}{I_x}$$

Find the moment of inertia I_x with respect to the x axis using parallel axis-theorem:

$$I_x = \frac{6(2)^3}{12} + (6 \times 2)(2)^2 + \frac{2(6)^3}{12} + (2 \times 6)(3-1)^2$$

$$\text{Max. Stress (com)} = \frac{(5 \times 12)(5)}{136} = \underline{\underline{2.21 \text{ ksi}}}$$

■ Example 4

A pair of channels fastened back-to-back will be used as a beam to resist a bending moment M_r of $60 \text{ kN} \cdot \text{m}$. If the maximum flexural stress must not exceed 120 MPa , select the most economical channel section listed in Appendix B of the textbook.

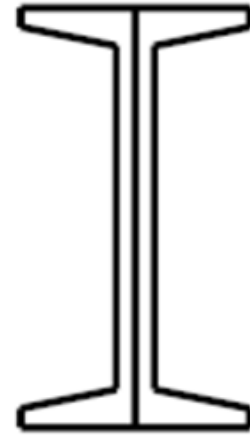

$\sigma = \frac{M}{S}$, However, we have two channels, hence

$$\sigma = \frac{M}{2S} \Rightarrow S = \frac{M}{2\sigma}$$

$$S = \frac{60 \times 10^3}{2(120 \times 10^6)} = 250 \times 10^{-6} \text{ m}^3 = 250 \times 10^3 \text{ mm}^3$$

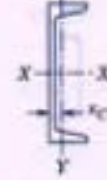

TABLE B-6

Standard Channels (SI Units)

Designation*	Area (mm ²)	Depth (mm)	FLANGE		Web Thickness (mm)	AXIS X-X			AXIS Y-Y			
			Width (mm)	Thickness (mm)		<i>I</i> (10 ⁶ mm ⁴)	<i>S</i> (10 ³ mm ³)	<i>r</i> (mm)	<i>I</i> (10 ⁶ mm ⁴)	<i>S</i> (10 ³ mm ³)	<i>r</i> (mm)	<i>x_c</i> (mm)
C457 × 86	11030	457.2	106.7	15.9	17.8	281	1230	160	7.41	87.2	25.9	21.9
× 77	9870	457.2	104.1	15.9	15.2	261	1140	163	6.83	83.1	26.4	21.8
× 68	8710	457.2	101.6	15.9	12.7	241	1055	167	6.29	79.0	26.9	22.0
× 64	8130	457.2	100.3	15.9	11.4	231	1010	169	5.99	76.9	27.2	22.3
C381 × 74	9465	381.0	94.4	16.5	18.2	168	882	133	4.58	61.9	22.0	20.3
× 60	7615	381.0	89.4	16.5	13.2	145	762	138	3.84	55.2	22.5	19.7
× 50	6425	381.0	86.4	16.5	10.2	131	688	143	3.38	51.0	23.0	20.0
C305 × 45	5690	304.8	80.5	12.7	13.0	67.4	442	109	2.14	33.8	19.4	17.1
× 37	4740	304.8	77.4	12.7	9.8	59.9	395	113	1.86	30.8	19.8	17.1
× 31	3930	304.8	74.7	12.7	7.2	53.7	352	117	1.61	28.3	20.3	17.7
C254 × 45	5690	254.0	77.0	11.1	17.1	42.9	339	86.9	1.64	27.0	17.0	16.5
× 37	4740	254.0	73.3	11.1	13.4	38.0	298	89.4	1.40	24.3	17.2	15.7
→ × 30	3795	254.0	69.6	11.1	9.6	32.8	259	93.0	1.17	21.6	17.6	15.4
× 23	2895	254.0	66.0	11.1	6.1	28.1	221	98.3	0.949	19.0	18.1	16.1
C229 × 30	3795	228.6	67.3	10.5	11.4	25.3	221	81.8	1.01	19.2	16.3	14.8
× 22	2845	228.6	63.1	10.5	7.2	21.2	185	86.4	0.803	16.6	16.8	14.9
× 20	2540	228.6	61.8	10.5	5.9	19.9	174	88.4	0.733	15.7	17.0	15.3
C203 × 28	3555	203.2	64.2	9.9	12.4	18.3	180	71.6	0.824	16.6	15.2	14.4
× 20	2605	203.2	59.5	9.9	7.7	15.0	148	75.9	0.637	14.0	15.6	14.0
× 17	2180	203.2	57.4	9.9	5.6	13.6	133	79.0	0.549	12.8	15.9	14.5
C178 × 22	2795	177.8	58.4	9.3	10.6	11.3	127	63.8	0.574	12.8	14.3	13.5
× 18	2320	177.8	55.7	9.3	8.0	10.1	114	66.0	0.487	11.5	14.5	13.3
× 15	1850	177.8	53.1	9.3	5.3	8.87	99.6	69.1	0.403	10.2	14.8	13.7
C152 × 19	2470	152.4	54.8	8.7	11.1	7.24	95.0	54.1	0.437	10.5	13.3	13.1
× 16	1995	152.4	51.7	8.7	8.0	6.33	82.9	56.4	0.360	9.24	13.4	12.7
× 12	1550	152.4	48.8	8.7	5.1	5.45	71.8	59.4	0.288	8.06	13.6	13.0
C127 × 13	1705	127.0	47.9	8.1	8.3	3.70	58.3	46.5	0.263	7.37	12.4	12.1
× 10	1270	127.0	44.5	8.1	4.8	3.12	49.2	49.5	0.199	6.19	12.5	12.3
C102 × 11	1375	101.6	43.7	7.5	8.2	1.91	37.5	37.3	0.180	5.62	11.4	11.7
× 8	1025	101.6	40.2	7.5	4.7	1.60	31.6	39.6	0.133	4.64	11.4	11.6
C76 × 9	1135	76.2	40.5	6.9	9.0	0.862	22.6	27.4	0.127	4.39	10.6	11.6
× 7	948	76.2	38.0	6.9	6.6	0.770	20.3	28.4	0.103	3.82	10.4	11.1
× 6	781	76.2	35.8	6.9	4.6	0.691	18.0	29.7	0.082	3.31	10.3	11.1

*C means channel, followed by the nominal depth in mm, then the mass in kg per meter of length.

■ Example 5

Determine both the maximum flexural tensile and the maximum flexural compressive stresses produced by a resisting moment of $100 \text{ kN}\cdot\text{m}$ if the beam has the cross section shown in the figure.

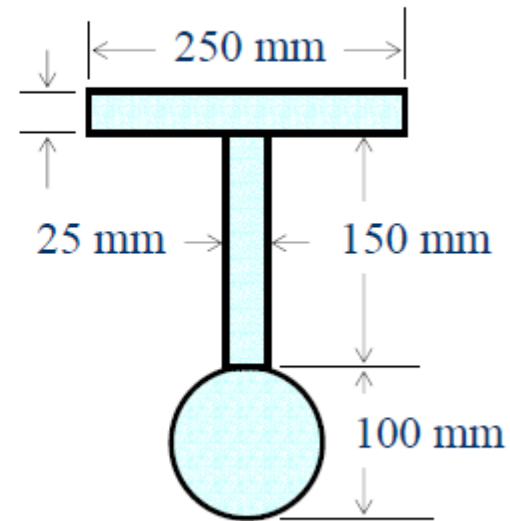

■ Example 5 (cont'd)

Locate the neutral axis from the upper edge:

$$y_c = \frac{250 \times 25(12.5) + 150 \times 25(25 + 75) + \frac{\pi(100)^2}{4}(25 + 150 + 50)}{250 \times 25 + 150 \times 25 + \frac{\pi(100)^2}{4}}$$
$$= \frac{2,220,270.87}{17,853.90}$$
$$= 124.36 \text{ mm}$$

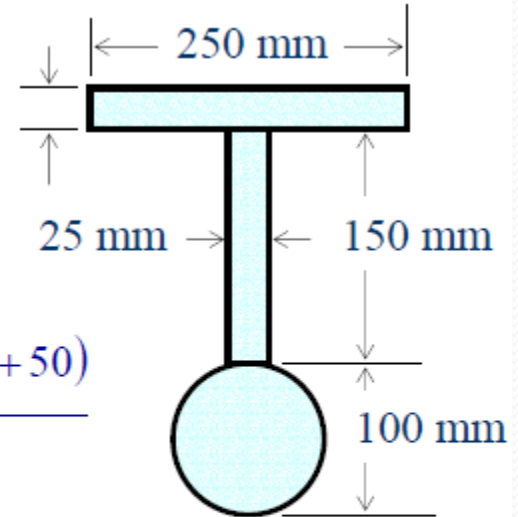

Calculate the moment of inertia with respect to the x axis:

$$I_x = \frac{250(124.36)^3}{3} - \frac{(250-25)(124.36-25)^3}{3} + \frac{25(175-124.36)^3}{3} \\ + \frac{\pi(100)^4}{64} + \frac{\pi(100)^2}{4}(225-124.36)^2 \\ = 172.243 \times 10^6 \text{ mm}^4 = 172.243 \times 10^{-6} \text{ m}^4$$

$$\sigma_{\max}(\text{ten}) = \frac{M_r y}{I} = \frac{100 \times 10^3 (275 - 124.36) \times 10^{-3}}{172.243 \times 10^{-6}} = \underline{87.5 \text{ MPa}}$$

$$\sigma_{\max}(\text{com}) = \frac{100 \times 10^3 (124.36) \times 10^{-3}}{172.243 \times 10^{-6}} = \underline{72.2 \text{ MPa}}$$

SAMPLE PROBLEM 4.1

The rectangular tube shown is extruded from an aluminum alloy for which $\sigma_Y = 150 \text{ MPa}$, $\sigma_U = 300 \text{ MPa}$ and $E = 70 \text{ GPa}$. Neglecting the effect of fillets, determine (a) the bending moment M for which the factor of safety will be 3.00, (b) the corresponding radius of curvature of the tube.

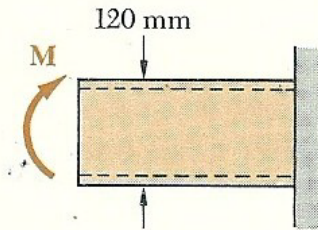
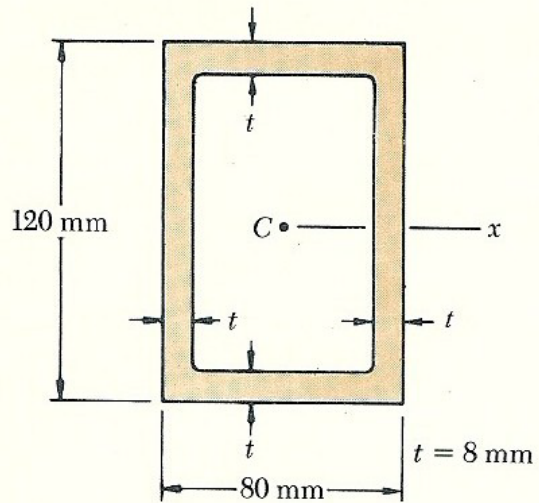

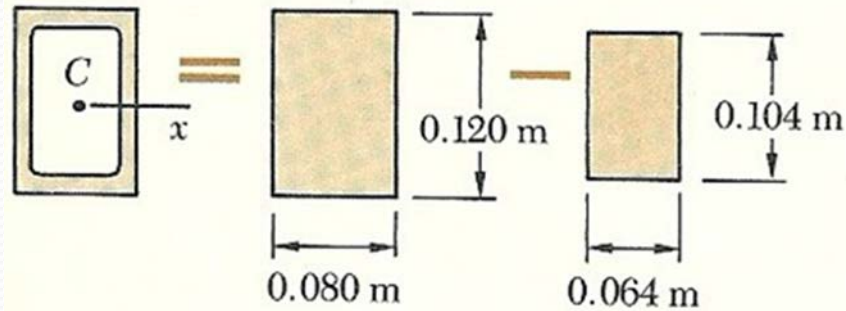

Moment of Inertia. Considering the cross-sectional area of the tube as the difference between the two rectangles shown and expressing all dimensions in meters, we write

$$I = \frac{1}{12}(0.080)(0.120)^3 - \frac{1}{12}(0.064)(0.104)^3 \quad I = 5.52 \times 10^{-6} \text{ m}^4$$

Allowable Stress. For a factor of safety of 3.00 and an ultimate stress of 300 MPa, we have

$$\sigma_{\text{all}} = \frac{\sigma_U}{F.S.} = \frac{300 \text{ MPa}}{3.00} = 100 \text{ MPa}$$

Since $\sigma_{\text{all}} < \sigma_Y$, the tube remains in the elastic range and we may apply the results of Sec. 4.4.

a. Bending Moment. With $c = \frac{1}{2}(0.120 \text{ m}) = 0.060 \text{ m}$, we write

$$\sigma_{\text{all}} = \frac{Mc}{I} \quad M = \frac{I}{c} \sigma_{\text{all}} = \frac{5.52 \times 10^{-6} \text{ m}^4}{0.060 \text{ m}} (100 \text{ MPa})$$

$$M = 9.20 \text{ kN} \cdot \text{m} \quad \blacktriangleleft$$

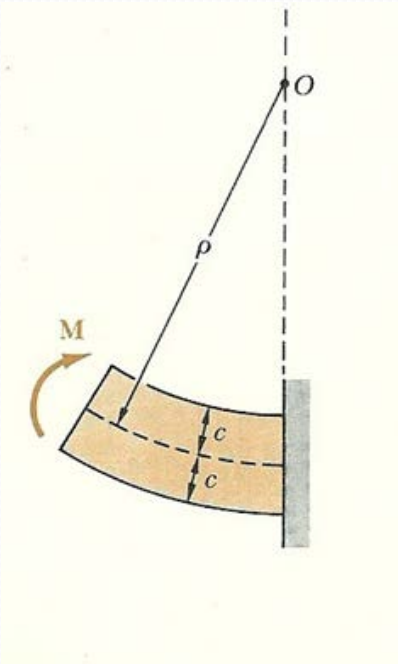

b. Radius of Curvature. Recalling that $E = 70 \text{ GPa}$, we substitute this value into Eq. (4.21) and find

$$\frac{1}{\rho} = \frac{M}{EI} = \frac{9.2 \text{ kN} \cdot \text{m}}{(70 \text{ GPa})(5.52 \times 10^{-6} \text{ m}^4)} = 23.8 \times 10^{-3} \text{ m}^{-1}$$

$$\rho = 42.0 \text{ m} \quad \blacktriangleleft$$

Alternate Solution. Since we know that the maximum stress is $\sigma_{\text{all}} = 100 \text{ MPa}$, we may determine the maximum strain ϵ_m and then use Eq. (4.9),

$$\epsilon_m = \frac{\sigma_{\text{all}}}{E} = \frac{100 \text{ MPa}}{70 \text{ GPa}} = 1429 \mu$$

$$\epsilon_m = \frac{c}{\rho}; \quad \rho = \frac{c}{\epsilon_{\text{max}}} = \frac{0.060 \text{ m}}{1429 \mu}$$

$$\rho = 42.0 \text{ m} \quad \blacktriangleleft$$

SAMPLE PROBLEM 4.2

A cast iron machine part is acted upon by the $3\text{-kN}\cdot\text{m}$ couple shown. Knowing that $E = 175\text{ GPa}$ and neglecting the effect of fillets, determine (a) the maximum tensile and compressive stresses in the casting, (b) the radius of curvature of the casting.

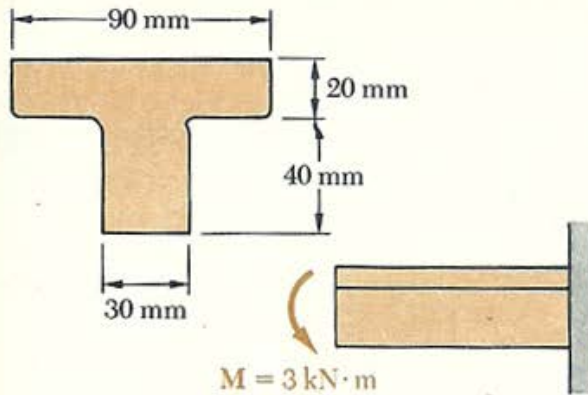

Centroid. We divide the T-shaped cross section into the two rectangles shown and write

	Area, cm^2	\bar{y} , cm	$\bar{y}A$, cm^3
1	$(2)(9) = 18$	5	90
2	$(4)(3) = 12$	2	24
	$\Sigma A = 30$		$\Sigma \bar{y}A = 114$

$$\bar{Y}\Sigma A = \Sigma \bar{y}A$$

$$\bar{Y}(30) = 114$$

$$\bar{Y} = 3.8\text{ cm}$$

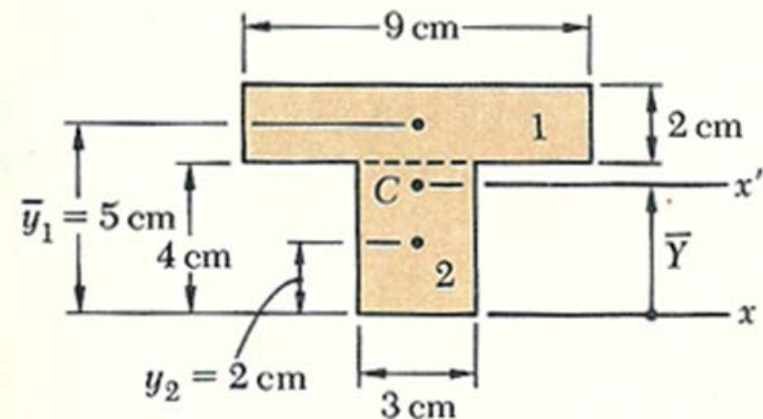

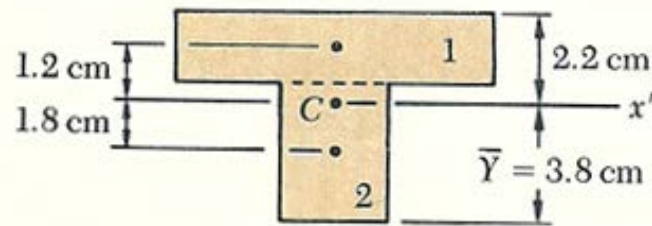

Centroidal Moment of Inertia. The parallel-axis theorem is used to determine the moment of inertia of each rectangle with respect to the axis x' which passes through the centroid of the composite section. Adding the moments of inertia of the rectangles, we write

$$\begin{aligned}
 I_{x'} &= \Sigma(\bar{I} + Ad^2) = \Sigma\left(\frac{1}{12}bh^3 + Ad^2\right) \\
 &= \frac{1}{12}(9)(2)^3 + (9 \times 2)(1.2)^2 + \frac{1}{12}(3)(4)^3 + (3 \times 4)(1.8)^2 \\
 &= 86.8 \text{ cm}^4 \\
 I &= 868 \times 10^{-9} \text{ m}^4
 \end{aligned}$$

a. Maximum Tensile Stress. Since the applied couple bends the casting downward, the center of curvature is located below the cross section. The maximum tensile stress occurs at point A, which is farthest from the center of curvature.

$$\sigma_A = \frac{Mc_A}{I} = \frac{(3 \text{ kN} \cdot \text{m})(0.022 \text{ m})}{868 \times 10^{-9} \text{ m}^4} \qquad \sigma_A = +76.0 \text{ MPa} \quad \blacktriangleleft$$

Maximum Compressive Stress. This occurs at point *B*; we have

$$\sigma_B = -\frac{Mc_B}{I} = -\frac{(3 \text{ kN} \cdot \text{m})(0.038 \text{ m})}{868 \times 10^{-9} \text{ m}^4} \quad \sigma_B = -131.3 \text{ MPa} \quad \blacktriangleleft$$

b. Radius of Curvature. From Eq. (4.21), we have

$$\begin{aligned} \frac{1}{\rho} &= \frac{M}{EI} = \frac{3 \text{ kN} \cdot \text{m}}{(175 \text{ GPa})(868 \times 10^{-9} \text{ m}^4)} \\ &= 19.75 \times 10^{-3} \text{ m}^{-1} \quad \rho = 50.6 \text{ m} \quad \blacktriangleleft \end{aligned}$$

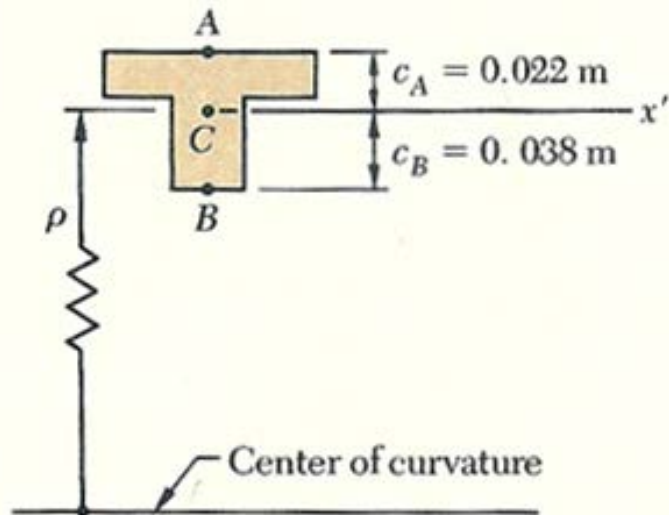

BEAMS: COMPOSITE BEAMS; STRESS CONCENTRATIONS

Composite Beams



- Bending of Composite Beams
 - In the previous discussion, we have considered only those beams that are fabricated from a single material such as steel.
 - However, in engineering design there is an increasing trend to use beams fabricated from two or more materials.

■ Bending of Composite Beams

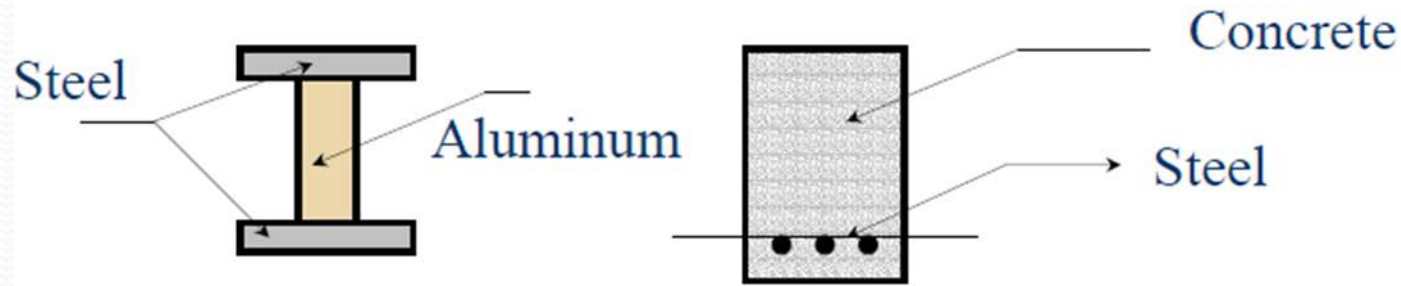

- These are called **composite beams**.
- They offer the opportunity of using each of the materials employed in their construction advantage.
- Consider a composite beam made of metal cover plates on the top and bottom with a plastic foam core as shown by the cross sectional area of Figure 26.

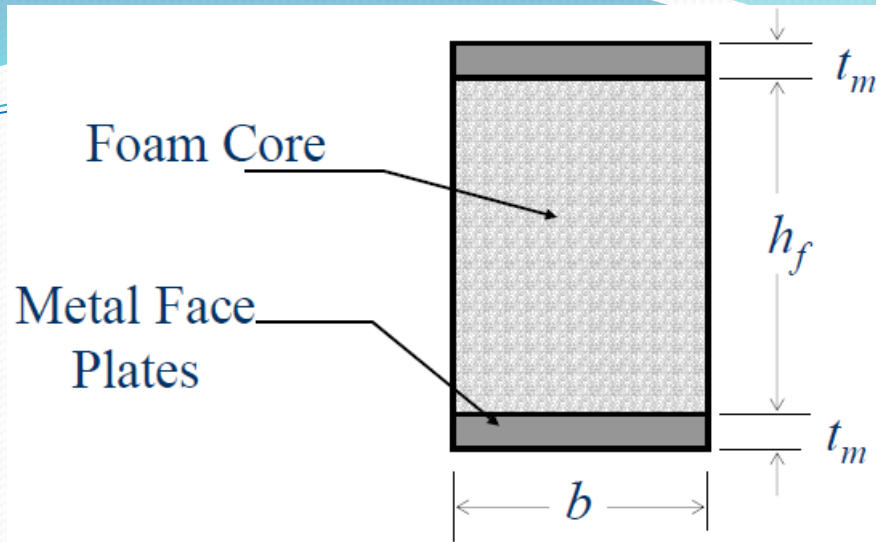

Figure 26

- The design concept of this composite beam is to use light-low strength foam to support the load-bearing metal plates located at the top and bottom.
- The strain is continuous across the interface between the foam and the cover plates. The stress in the foam is given by

$$\sigma_f = E_f \varepsilon \approx 0 \quad (53)$$

– The stress in the foam is considered zero because its modulus of elasticity E_f is small compared to the modulus of elasticity of the metal.

– Assumptions:

- Plane sections remain plane before and after loading.
- The strain is linearly distributed as shown in Figure 27.

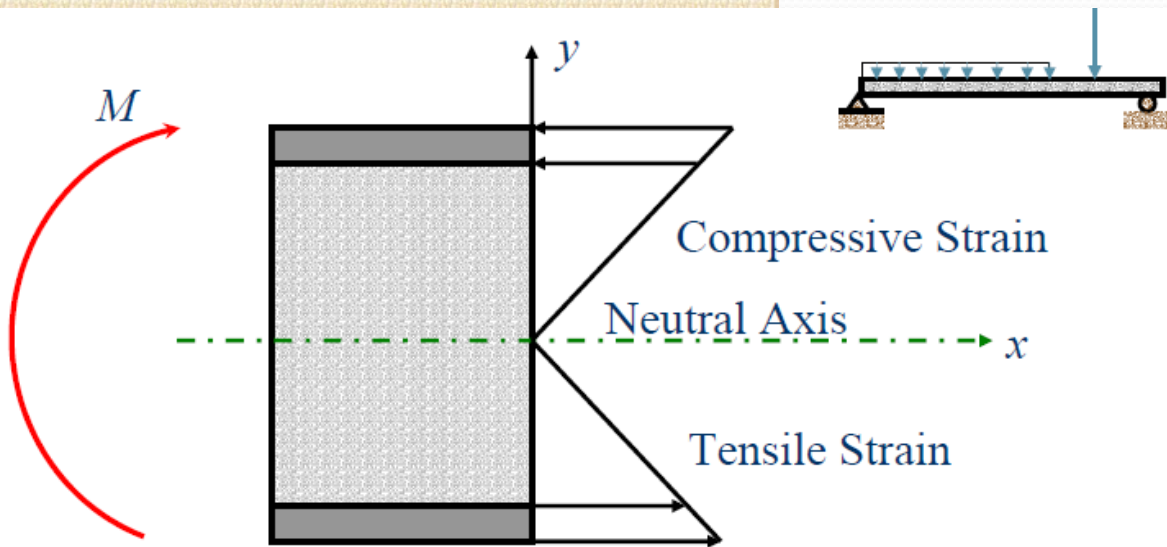

Figure 27

- Using Hooke's law, the stress in the metal of the cover plates can be expressed as

$$\sigma_m = \varepsilon E_m = -\frac{y}{\rho} E_m \quad (53)$$

but $E_m / \rho = M / I_x$, therefore

$$\sigma_m = -\frac{My}{I_x} \quad (54)$$

- The relation for the stress is the same as that established earlier; however, the foam does not contribute to the load carrying capacity of the beam because its modulus of elasticity is negligible.
- For this reason, the foam is not considered when determining the moment of inertia I_x .

- Under these assumptions, the moment of inertia about the neutral axis is given by

$$I_{NA} \cong 2Ad^2 = 2 \left[bt_m \left(\frac{h_f t_m}{2} \right)^2 \right] = \frac{bt_m}{2} (h_f + t_m)^2 \quad (55)$$

- Combining Eqs 54 and 55, the maximum stress in the metal is computed as

$$\sigma_{\max} = \frac{M(h_f + 2t_m)}{bt_m (h_f + t_m)^2} \quad (56)$$

■ Bending of Members Made of Several Materials

- The derivation given for foam core with metal plating was based on the assumption that the modulus of elasticity E_f of the foam is so negligible, that is, it does not contribute to the load-carrying capacity of the composite beam.
- When the moduli of elasticity of various materials that make up the beam structure are not negligible and they should be accounted for, then procedure for calculating the normal stresses and shearing stresses on the section will follow different approach, the transformed section of the member.

■ Transformed Section

- Consider a bar consisting of two portions of different materials bonded together as shown in Fig. 28. This composite bar will deform as described earlier.

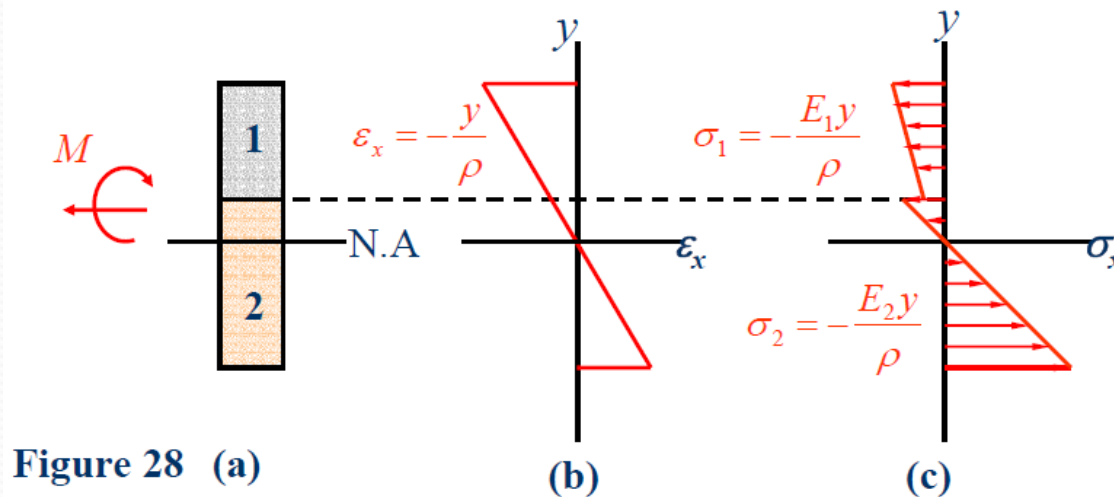

- Thus the normal strain ϵ_x still varies linearly with the distance y from the neutral axis of the section (see Fig 28b), and the following formula holds:

$$\epsilon_x = -\frac{y}{\rho} \quad (57)$$

- Because we have different materials, we cannot simply assume that the neutral axis passes through the centroid of the composite section.
- In fact one of the goal of this discussion will be to determine the location of this axis.

We can write:

$$\sigma_1 = E_1 \varepsilon_x = -\frac{E_1 y}{\rho} \quad (58a)$$

$$\sigma_2 = E_2 \varepsilon_x = -\frac{E_2 y}{\rho} \quad (58b)$$

From Eq. 58, it follows that

$$dF_1 = \sigma_1 dA = -\frac{E_1 y}{\rho} dA \quad (59a)$$

$$dF_2 = \sigma_2 dA = -\frac{E_2 y}{\rho} dA \quad (59b)$$

- But, denoting by n the ratio E_2/E_1 of the two moduli of elasticity, dF_2 can be expressed as

$$dF_2 = -\frac{(nE_1)y}{\rho} dA = -\frac{E_1 y}{\rho} (ndA) \quad (60)$$

- Comparing Eqs. 59a and 60, it is noted that the same force dF_2 would be exerted on an element of area $n dA$ of the first material.
- This means that the resistance to bending of the bar would remain the same if both portions were made of the first material, providing that the width of each element of the lower portion were multiplied by the factor n .
- The widening (if $n > 1$) and narrowing ($n < 1$) must be accomplished in a direction parallel to the neutral axis of the section.

■ Transformed Section

Figure 29

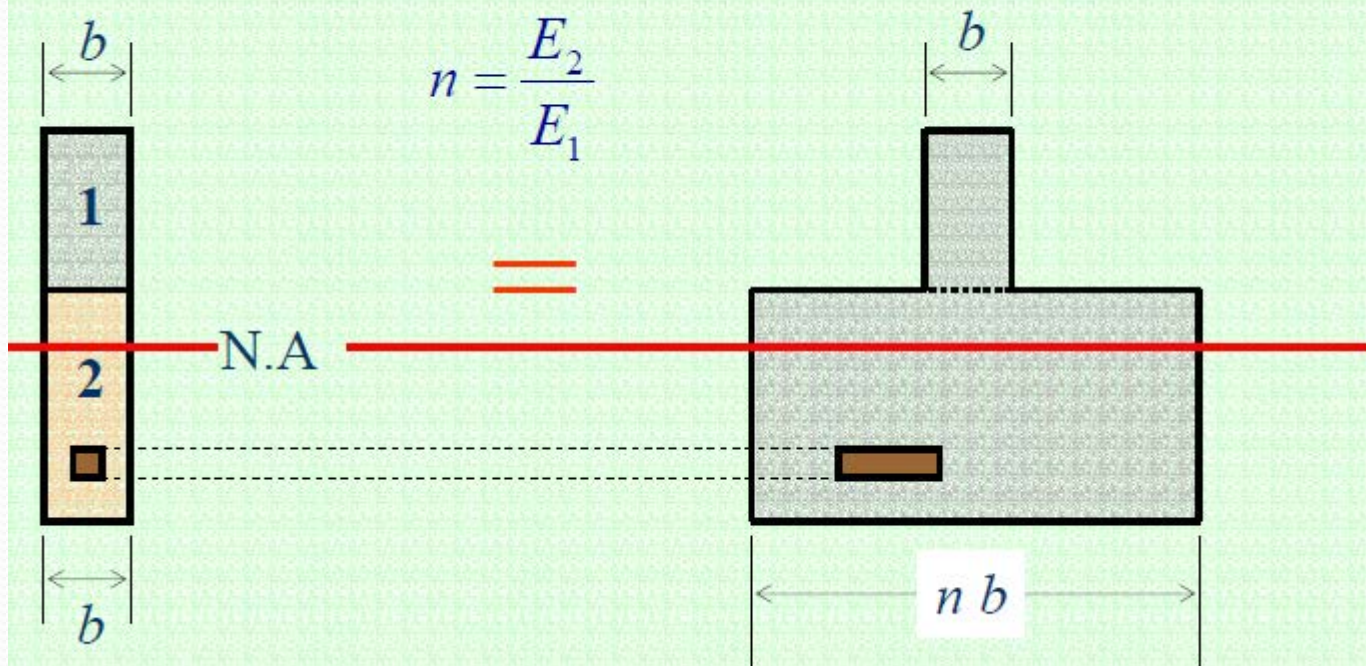

- Since the transformed section represents the cross section of a member made of a homogeneous material with a modulus of elasticity E_1 , the previous method may be used to find the neutral axis of the section and the stresses at various points of the section.
- Figure 30 shows the fictitious distribution of normal stresses on the section.

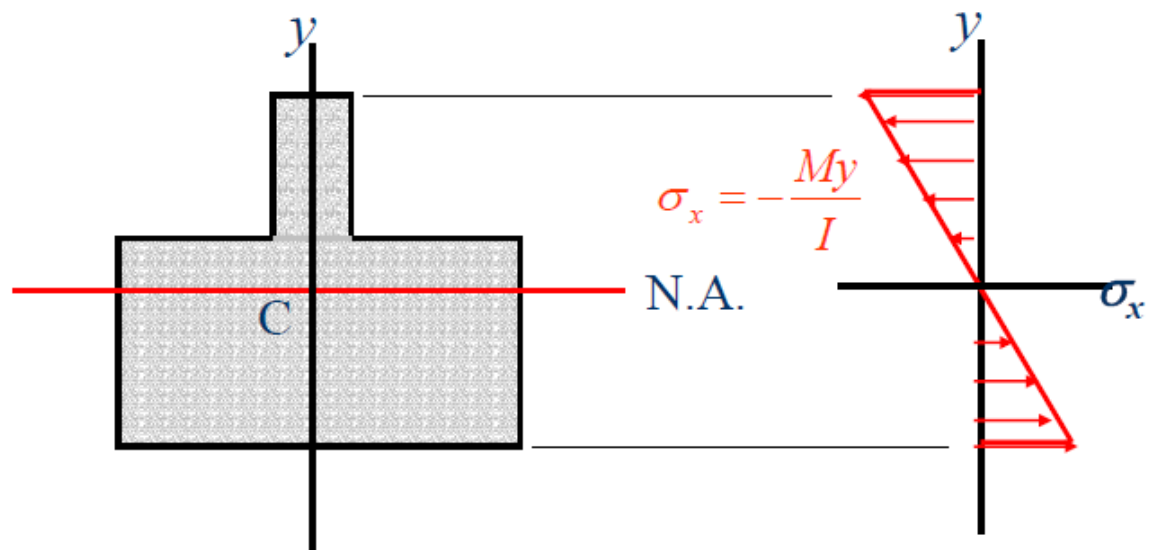

Figure 30. Distribution of Fictitious Normal Stress on Cross Section

■ Stresses on Transformed Section

1. To obtain the stress σ_1 at a point located in the upper portion of the cross section of the original composite beam, the stress is simply computed from My/I .
2. To obtain the stress σ_2 at a point located in the upper portion of the cross section of the original composite beam, stress σ_x computed from My/I is multiplied by n .

■ Example

A steel bar and aluminum bar are bonded together to form the composite beam shown. The modulus of elasticity for aluminum is 70 GPa and for steel is 200 GPa. Knowing that the beam is bent about a horizontal axis by a moment $M = 1500 \text{ N}\cdot\text{m}$, determine the maximum stress in (a) the aluminum and (b) the steel.

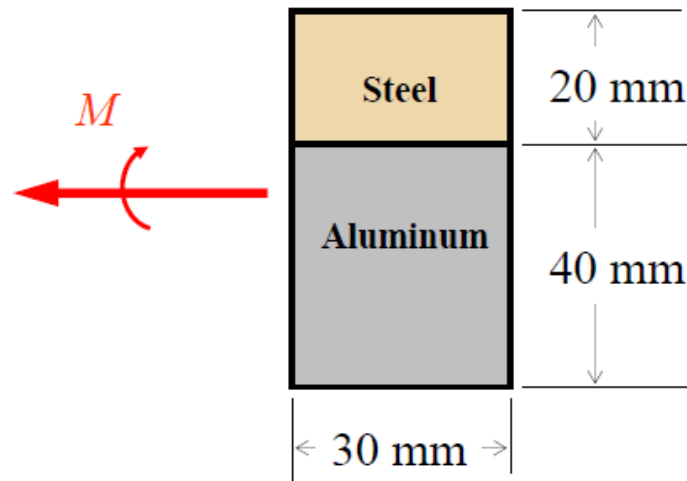

First, because we have different materials, we need to transform the section into a section that represents a section that is made of homogeneous material, either steel or aluminum.

We have

$$n = \frac{E_s}{E_a} = \frac{200}{70} = 2.857$$

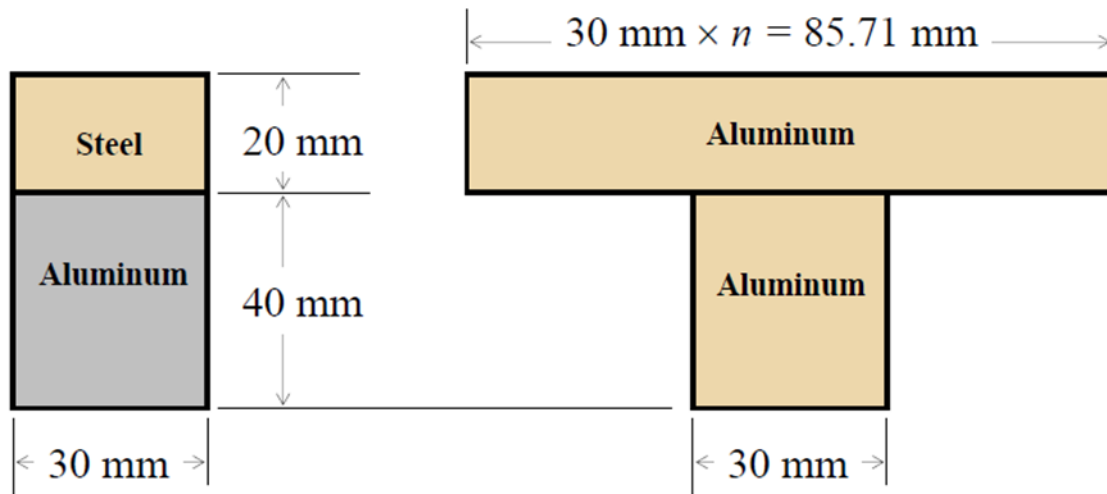

Figure 31a

Figure 31b

Consider the transformed section of Fig. 31b, therefore

$$y_c = \frac{10(85.71 \times 20) + 40(30 \times 40)}{(85.71 \times 20) + (30 \times 40)} = 22.353 \text{ mm from top}$$

$$I_{NA} = \frac{85.71(22.353)^3}{3} - \frac{(85.71 - 30)(22.353 - 20)^3}{3} + \frac{30(40 + 20 - 22.353)^3}{3} = 852.42 \times 10^3 \text{ mm}^4 = 852.42 \times 10^{-9} \text{ m}^4$$

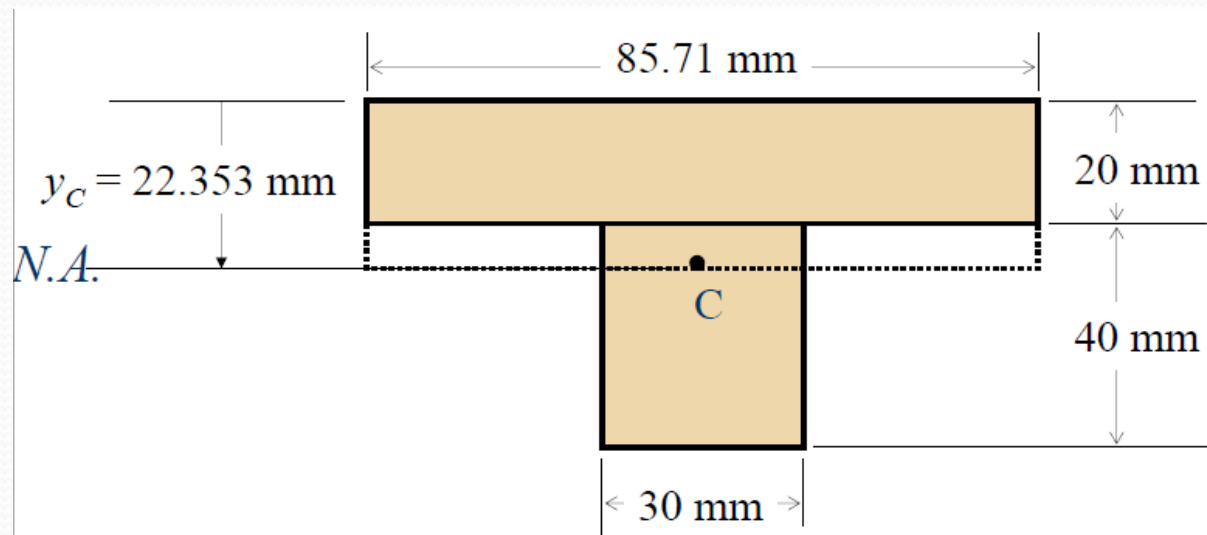

a) Maximum normal stress in aluminum occurs at extreme lower fiber of section, that is at $y = -(20+40-22.353) = -37.65$ mm.

$$\sigma_{al} = -\frac{My}{I} = -\frac{1500(-37.65 \times 10^{-3})}{852.42 \times 10^{-9}} = 66.253 \times 10^6 \text{ Pa}$$

$$= +66.253 \text{ MPa (T)}$$

b) Maximum normal stress in steel occurs at extreme upper fiber of the cross section, that is. at $y = + 22.353$ mm.

$$\sigma_{st} = -n \frac{My}{I} = -(2.867) \frac{1500(22.353 \times 10^{-3})}{852.42 \times 10^{-9}} = -112.8 \times 10^6 \text{ Pa}$$
$$= 112.8 \text{ MPa (C)}$$

■ Reinforced Concrete Beam

- An important example of structural members made of different materials is demonstrated by reinforced concrete beams.
- These beams, when subjected to positive bending moments, are reinforced by steel rods placed a short distance above their lower face as shown in Figure 33a.

Figure 32

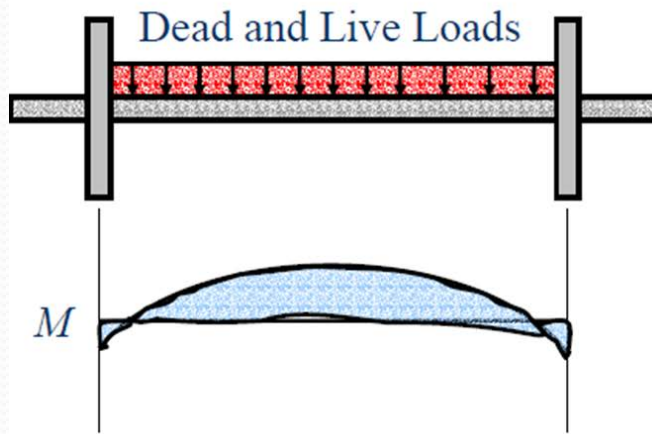
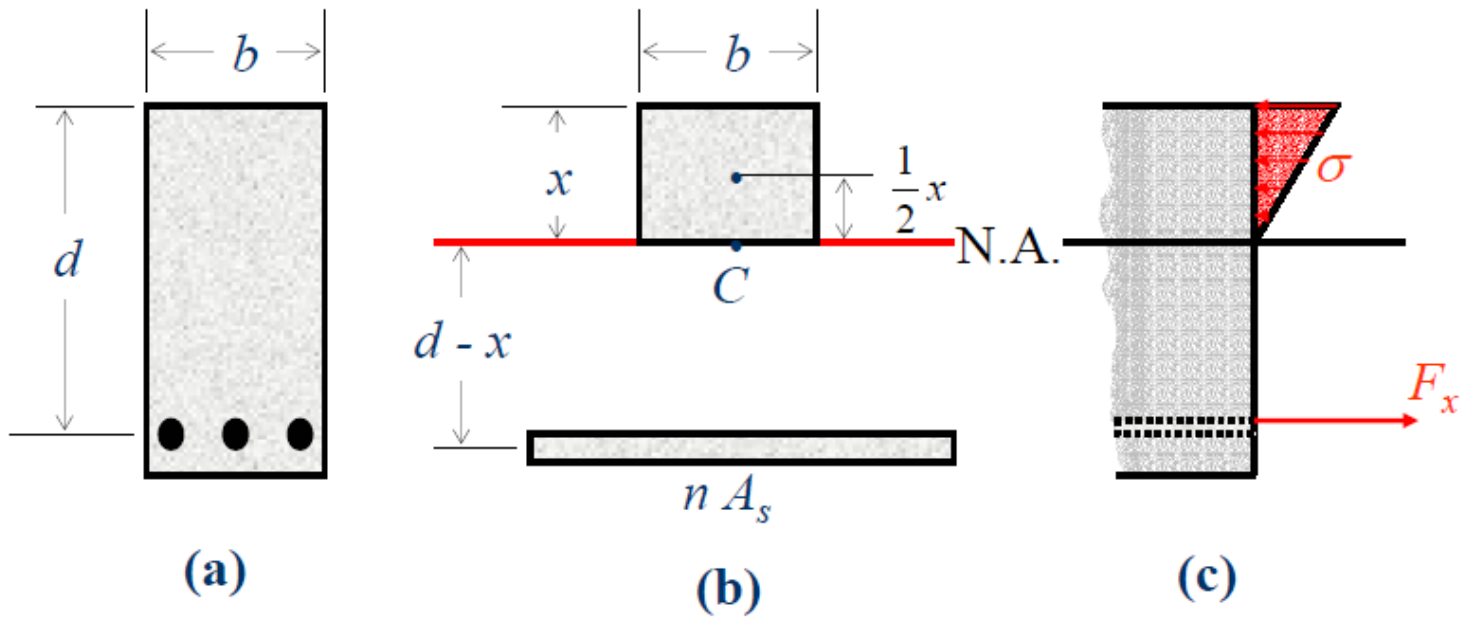

Figure 33



- Concrete is very weak in tension, so it will crack below the neutral surface and the steel rods will carry the entire tensile load.
- The upper part of the concrete beam will carry the compressive load.
- To obtain the transformed section, the total cross-sectional area A_s of steel bar is replaced by an equivalent area nA_s .

- The ratio n is given by

$$n = \frac{\text{Modulus of Elasticity for Steel}}{\text{Modulus of Elasticity for Concrete}} = \frac{E_s}{E_c}$$

- The position of the neutral axis is obtained by determining the distance x from the upper face of the beam (upper fiber) to the centroid C of the transformed section.

- Note that the first moment of transformed section with respect to neutral axis must be zero.
- Since the the first moment of each of the two portions of the transformed section is obtained by multiplying its area by the distance of its own centroid from the neutral axis, we get

$$\frac{x}{2}(bx) - (d - x)(nA_s) = 0$$

or

$$\frac{1}{2}bx^2 + nA_s x - nA_s d = 0 \quad (61)$$

- Solving the quadratic equation for x , both the position of the neutral axis in the beam and the portion of the cross section of the concrete beam can be obtained.

The neutral axis for a concrete beam is found by solving the quadratic equation:

$$\frac{1}{2}bx^2 + nA_sx - nA_s d = 0 \quad (62)$$

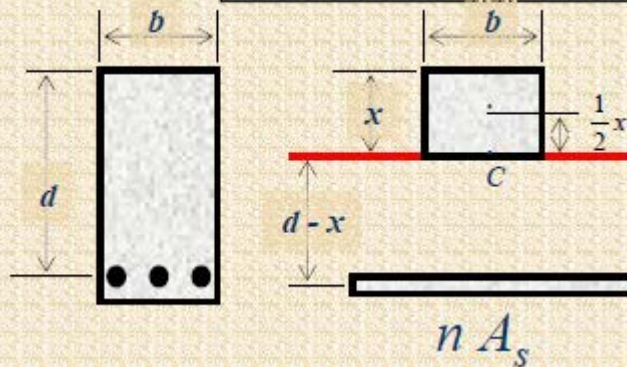

■ Example

A concrete floor slab is reinforced by $\frac{5}{8}$ -in diameter steel rods placed 1 in. above the lower face of the slab and spaced 6 in. on centers. The modulus of elasticity is 3×10^6 psi for concrete used and 30×10^6 psi for steel. Knowing that a bending moment of 35 kip·in is applied to each 1-ft width of the slab, determine (a) the maximum stress in concrete and (b) the stress in the steel.

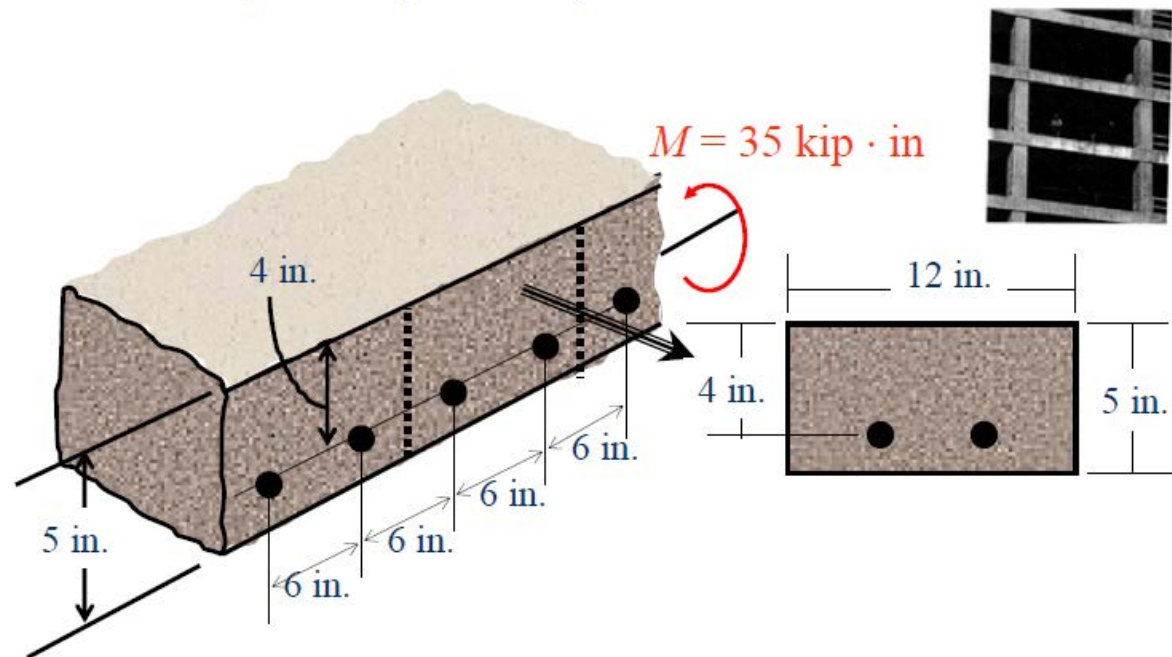

– Transformed Section

- Consider a portion of the slab 12 in. wide, in which there are two $\frac{5}{8}$ -in diameter rods having a total cross-sectional area

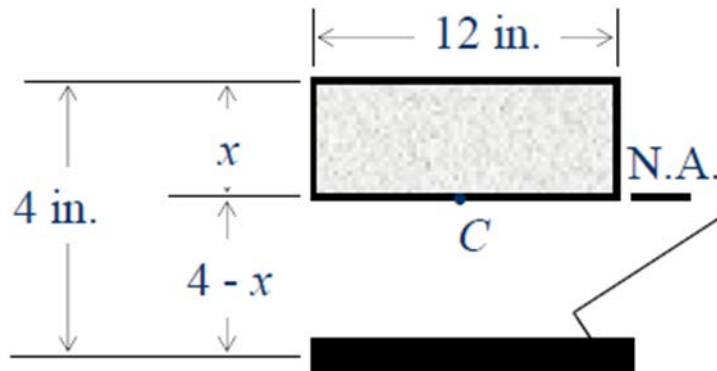

$$A_s = 2 \left[\frac{\pi \left(\frac{5}{8} \right)^2}{4} \right] = 0.614 \text{ in}^2$$

$$n = \frac{E_s}{E_c} = \frac{30 \times 10^6}{3 \times 10^6} = 10$$

$$nA_s = 10(0.614) = 6.14 \text{ in}^2$$

– Neutral Axis

- The neutral axis of the slab passes through the centroid of the transformed section. Using Eq. 62:

Quadratic
Formula

$$x = \frac{-b \pm \sqrt{b^2 - 4ac}}{2a}$$

$$x_1 = 1.575 \text{ take}$$

$$x_2 = -2.599$$

$$\frac{1}{2}bx^2 + nA_sx - nA_s d = 0$$

$$\frac{1}{2}(12)x^2 + 6.14x - 6.14(4) = 0$$

$$6x^2 + 6.14x - 24.56 = 0$$

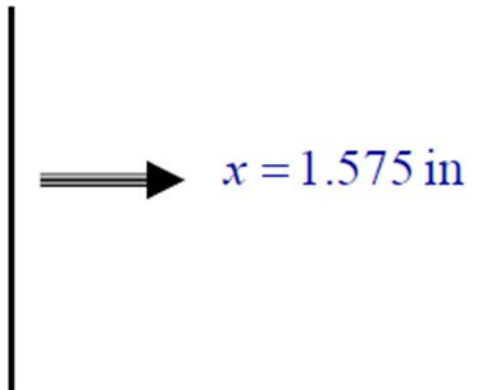
$$x = 1.575 \text{ in}$$

– Moment of Inertia

- The centroidal moment of inertia of the transformed section is

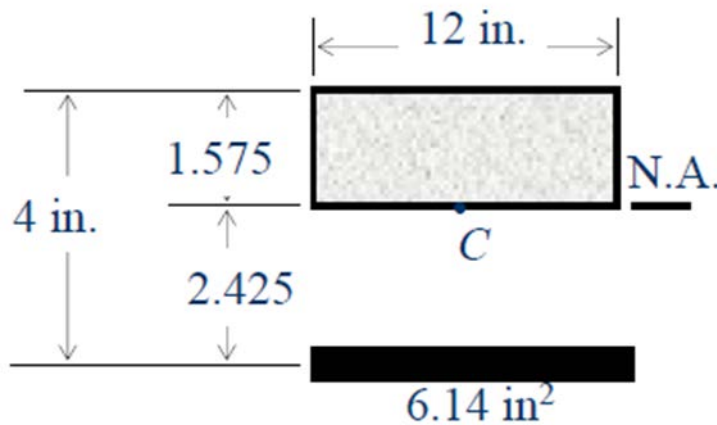

$$I = \frac{12(1.575)^3}{3} + 6.14(2.425)^2 = 51.7 \text{ in}^4$$

Maximum stress in concrete:

$$\sigma_c = -\frac{My}{I} = -\frac{35(1.575)}{51.7} = \underline{\underline{-1.066 \text{ ksi (C)}}}$$

Stress in steel:

$$\sigma_s = -n\frac{My}{I} = -(10)\frac{35(-2.425)}{51.7} = \underline{\underline{+16.42 \text{ ksi (T)}}}$$

4.57 Knowing that the bending moment in the reinforced concrete beam shown is $+150 \text{ kip}\cdot\text{ft}$ and that the modulus of elasticity is $3.75 \times 10^6 \text{ psi}$ for the concrete and $30 \times 10^6 \text{ psi}$ for the steel, determine (a) the stress in the steel, (b) the maximum stress in the concrete.

PROBLEM 4.57

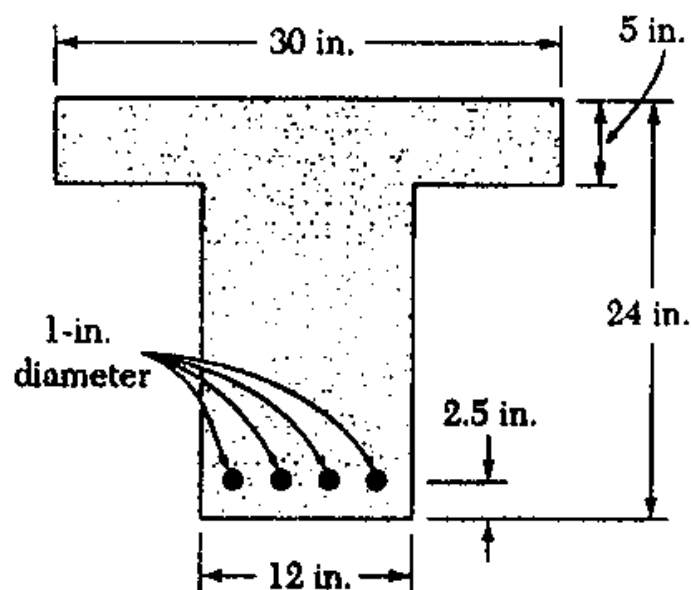

SOLUTION

$$n = \frac{E_s}{E_c} = \frac{30 \times 10^6}{3.75 \times 10^6} = 8.0$$

$$A_s = 4 \frac{\pi}{4} d^2 = 4 \left(\frac{\pi}{4} \right) (1)^2 = 3.1416 \text{ in}^2$$

$$n A_s = 25.133 \text{ in}^2$$

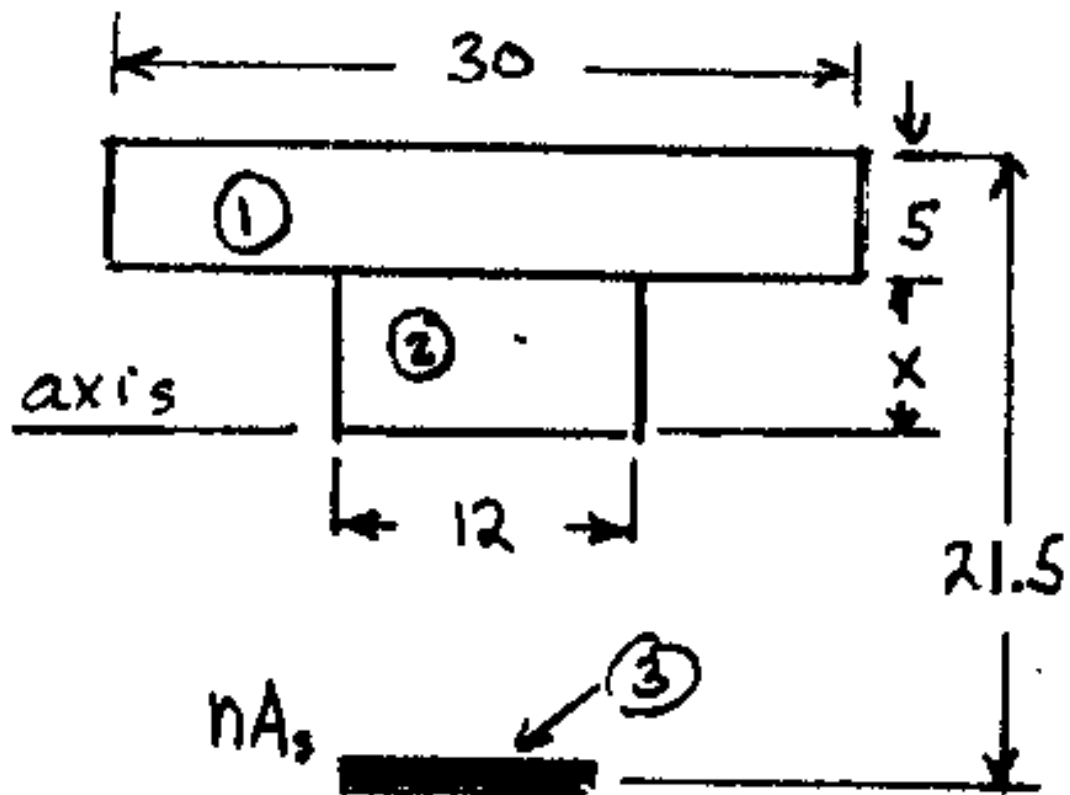

Locate the neutral axis

$$(30)(5)(x + 2.5) + 12 \times \frac{x}{2} - (25.133)(16.5 - x) = 0$$

$$150x + 375 + 6x^2 - 414.69 + 25.133x = 0$$

$$6x^2 + 175.133x - 39.69 = 0$$

Solve for x

$$x = \frac{-175.133 + \sqrt{(175.133)^2 + (4)(6)(39.69)}}{(2)(6)} = 0.225 \text{ in.}$$

$$16.5 - x = 16.275 \text{ in.}$$

$$I_1 = \frac{1}{12} b h_1^3 + A_1 d_1^2 = \frac{1}{12} (30)(5)^3 + (30)(5)(2.725)^2 = 1426.3 \text{ in}^4$$

$$I_2 = \frac{1}{3} b_2 x^3 = \frac{1}{3} (12)(0.225)^3 = 0.1 \text{ in}^4$$

$$I_3 = n A_3 d_3^2 = (25.133)(16.275)^2 = 6657.1 \text{ in}^4$$

$$I = I_1 + I_2 + I_3 = 8083.5 \text{ in}^4$$

$$\sigma = -\frac{nMy}{I} \quad \text{where} \quad M = 150 \text{ kip}\cdot\text{ft} = 1800 \text{ kip}\cdot\text{in.}$$

(a) Steel $n = 8.0$, $y = -16.275 \text{ in}$

$$\sigma = -\frac{(8.0)(1800)(-16.275)}{8083.5} = 29.0 \text{ ksi}$$

(b) Concrete $n = 1.0$, $y = 5.225 \text{ in}$

$$\sigma = -\frac{(1.0)(1800)(5.225)}{8083.5} = -1.163 \text{ ksi}$$

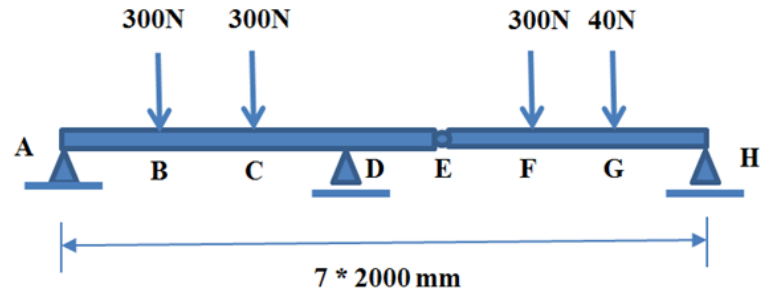
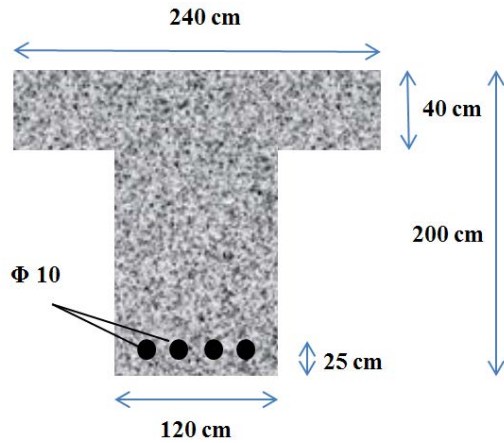

The reinforced concrete beam shown is subjected to a load pattern given in the figure. Knowing that the modulus of elasticity is 37.5 GPa for the concrete and 300 GPa for the steel, determine

- the stress in the steel
- the maximum stress in the concrete.