

Polymer Processing

There are many processes for plastics. Selection of a process depends on many factors including:

- Quantity and production rate**
- Dimensional accuracy and surface finish**
- Form and detail of the product**
- Nature of material**
- Size of final product**

In general, plastics processes have three phases:

- 1. Heating - To soften or melt the plastic**
- 2. Shaping / Forming - Under constraint of some kind**
- 3. Cooling - So that it retains its shape**

Thermoplastics start as regular pellets or granules and can be remelted.

Thermosetting materials start as liquids/syrups, often called "resins", as powders or partially cured products ("preforms") which need heat for the shaping phase. The shaping is accompanied by a chemical reaction, which means that the material does not soften on reheating. The reaction may be exothermic (giving heat out), in which case cooling is required.

Processes

- 1. Thermoforming**
- 2. Compression and transfer molding**
- 3. Rotational molding and sintering**
- 4. Extrusion**
- 5. Extrusion-based processes**
- 6. Injection molding**
- 7. Blow molding**
- 8. Plastic foam molding**

1. Thermoforming



Gift packaging



Communication packaging



AUTOMOBILE INNER DECORATION PACKAGING



SPECIDIFFERENCE PACKAGING

Thermoforming

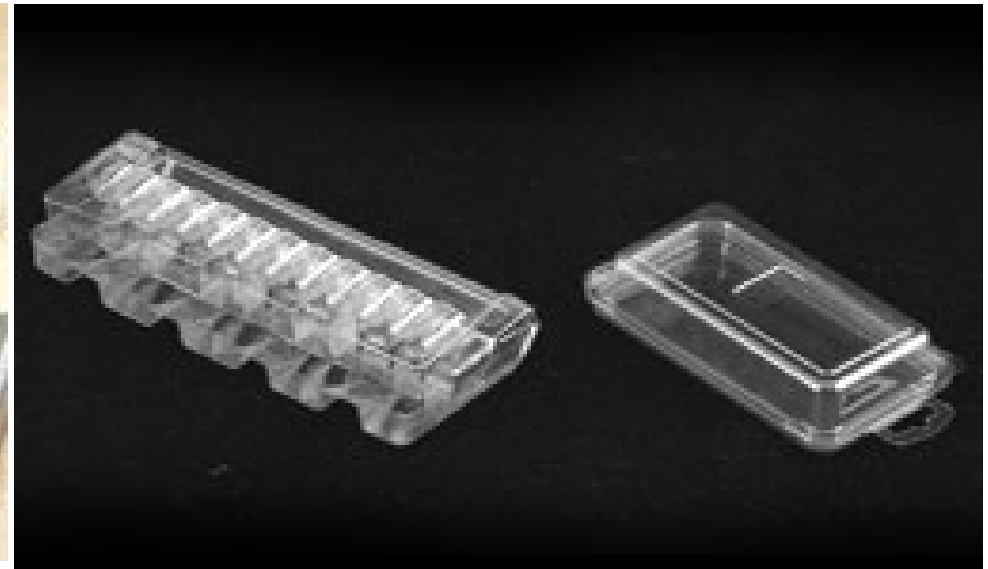
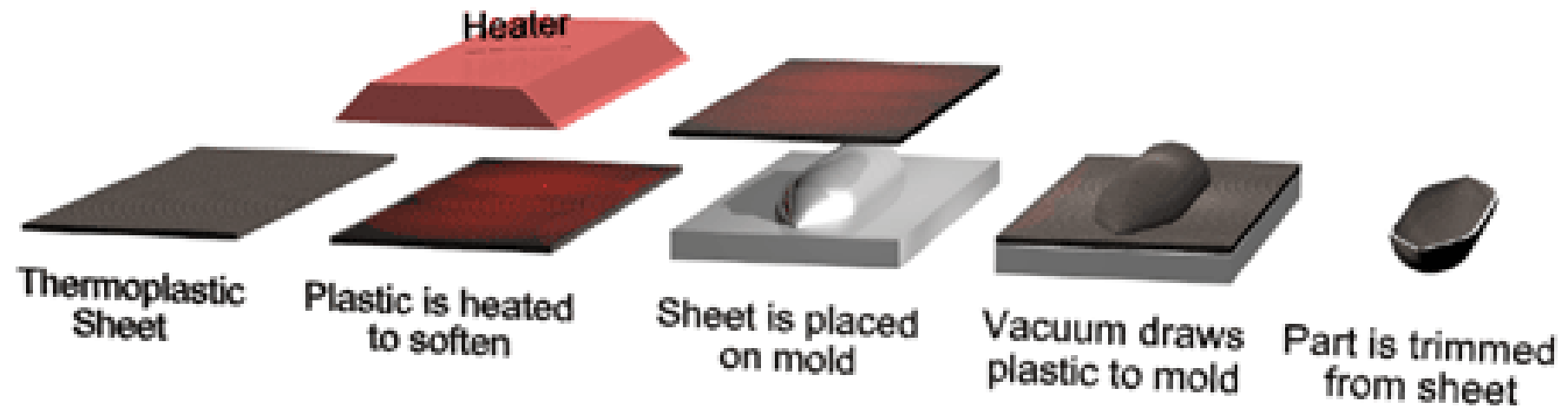

- air pressure and plug assisted forming of the softened sheet.**
- invariably automated and faster cycle times**
- only thermoplastics sheet can be processed by this method.**
- The largest application is for Food Packaging.**
- Other industries include Toiletries, Pharmaceuticals and Electronics**



-Food related applications such as Meat Trays, Microwave & Deep Freeze Containers, Ice Cream and Margarine Tubs, Snack Tubs, Bakery and Patisserie packaging, Sandwich Packs and Vending Drink Cups

-Manufacturing Collation trays, Blister packaging and Point of Sale display trays.



2. Compression and transfer molding

Thermoset Compression/Transfer Molding

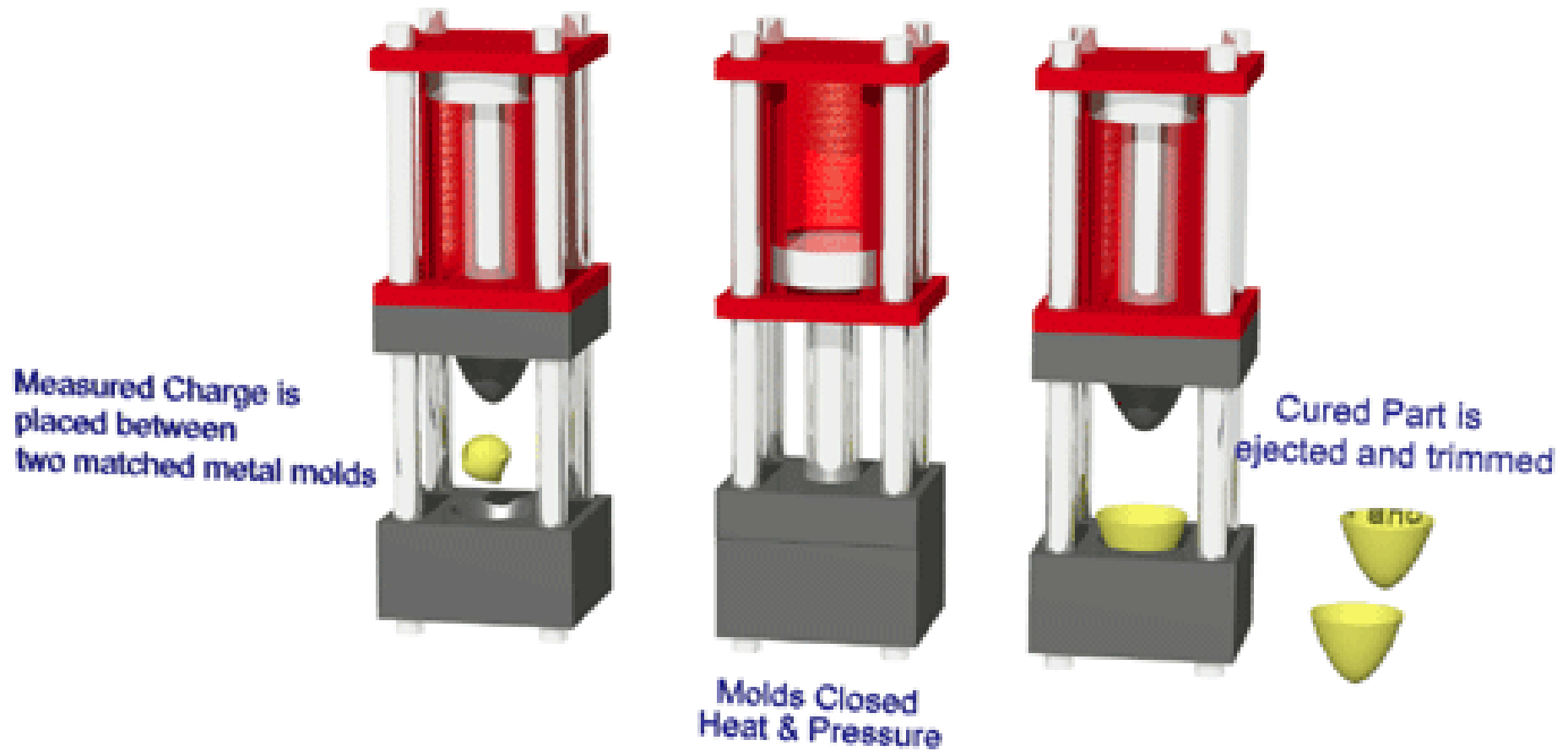

- place a pre-weighed amount of material in a matched metal mold and closing the mold.
- heat and pressure cause the material to liquify and flow into the voids in the tool where it chemically reacts and hardens into the final shape.
- very large shapes can be molded in compression presses.



Advantages of compression molding (compared with injection molding)

- Low scrap arisings**
- Low orientation in the moldings**
 - well distributed fibrous fillers**
 - low residual stress product**
 - retained mechanical and electrical properties**
 - low mold maintenance**
 - low capital and tooling costs**

Thermoset Resin Transfer Molding

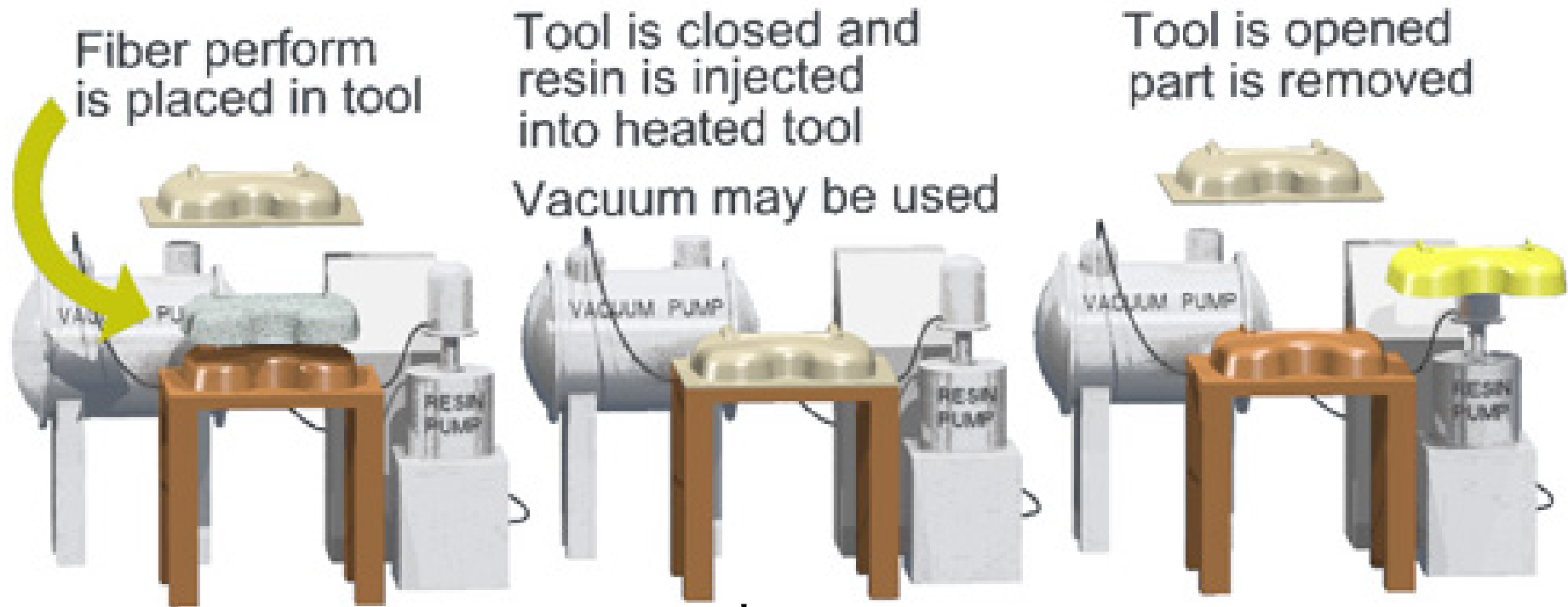

- พัฒนามาจาก compression คือจะมีที่ใส่สารแล้วค่อยกดอัดผ่าน runners ไปสู่ cavities ซึ่งเกิดขึ้นภายในแม่พิมพ์
- ต้องการให้ได้ส่วนที่เล็ก ๆ ของแบบได้ง่ายขึ้น
- ลดการสูญเสียหรือแตกหักจากส่วนของแม่พิมพ์ที่บางหรือซับซ้อน
- เร็วกว่า compression เพราะ heat transfer ในช่วงที่ผ่าน runner

Disadvantages when compared with compression

- Give unwelcome orientation in the product**
- Increase wear and maintenance costs**
- Tooling is more complex and more expensive**
- Runners owe scrap**



3. Rotational molding and sintering

Thermoplastic - Rotational Molding

Plastic powder is added to aluminum mold

Mold is clamped shut

Mold is rotated while heat is applied

Mold is air or water cooled to allow part to solidify

Tool is opened, part is removed



-cast hollow plastic parts with few restrictions regarding size or complexity

Very stable parts - no molded in stresses

Low tooling cost for large parts

Suited for low volume production

Can produce complex part geometries

Can mold in metal inserts and graphics



◀ return

▶ continue

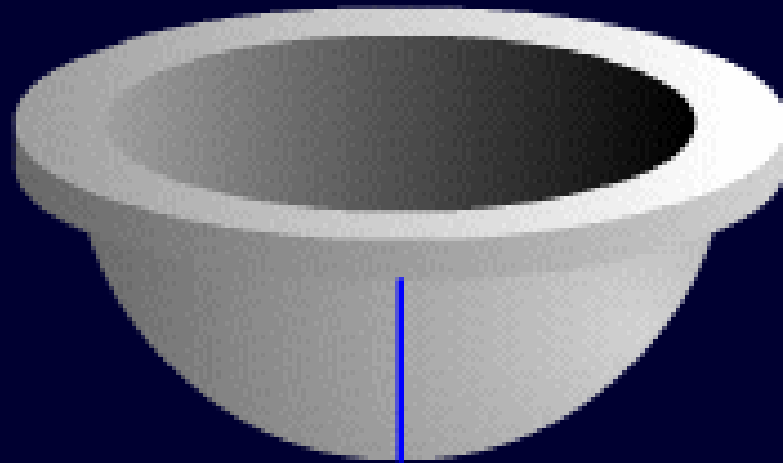

Rotational Molding uses relatively low cost molds and processes polymer at very low shear rates. The material experiences higher temperatures for longer times than other process methods.

Thermoplastic - Rotational Molding

Plastic powder is added
to aluminum mold

Mold is clamped shut

Mold is rotated while heat is applied

Mold is air or water cooled
to allow part to solidify

Tool is opened,
part is removed



4.Extrusion

Thermoplastic Profile Extrusion

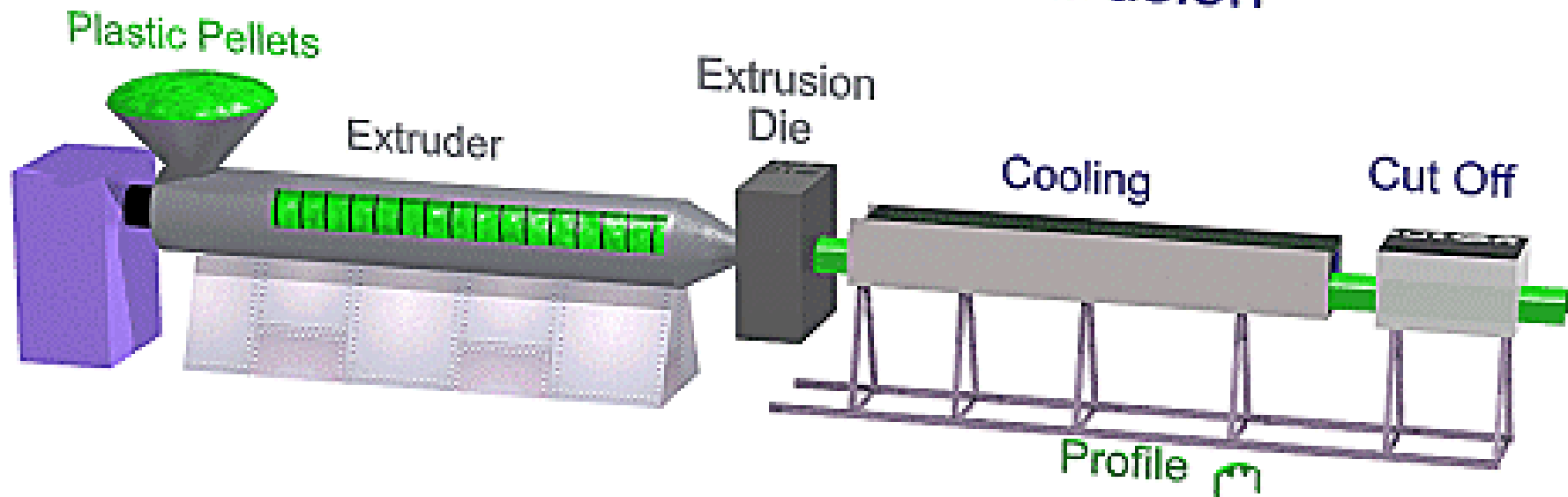

-the forcing of a plastic or molten material through a shaped die by means of pressure.

Single screw extruder

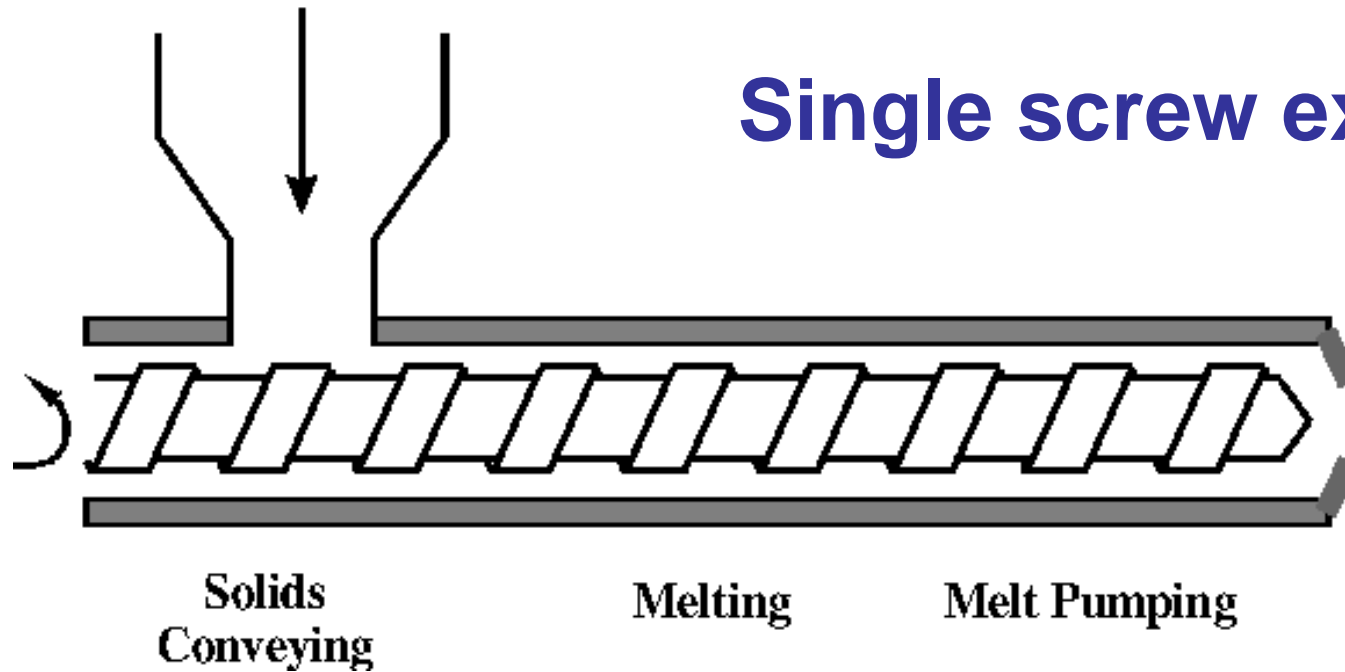

Twin screw extruder

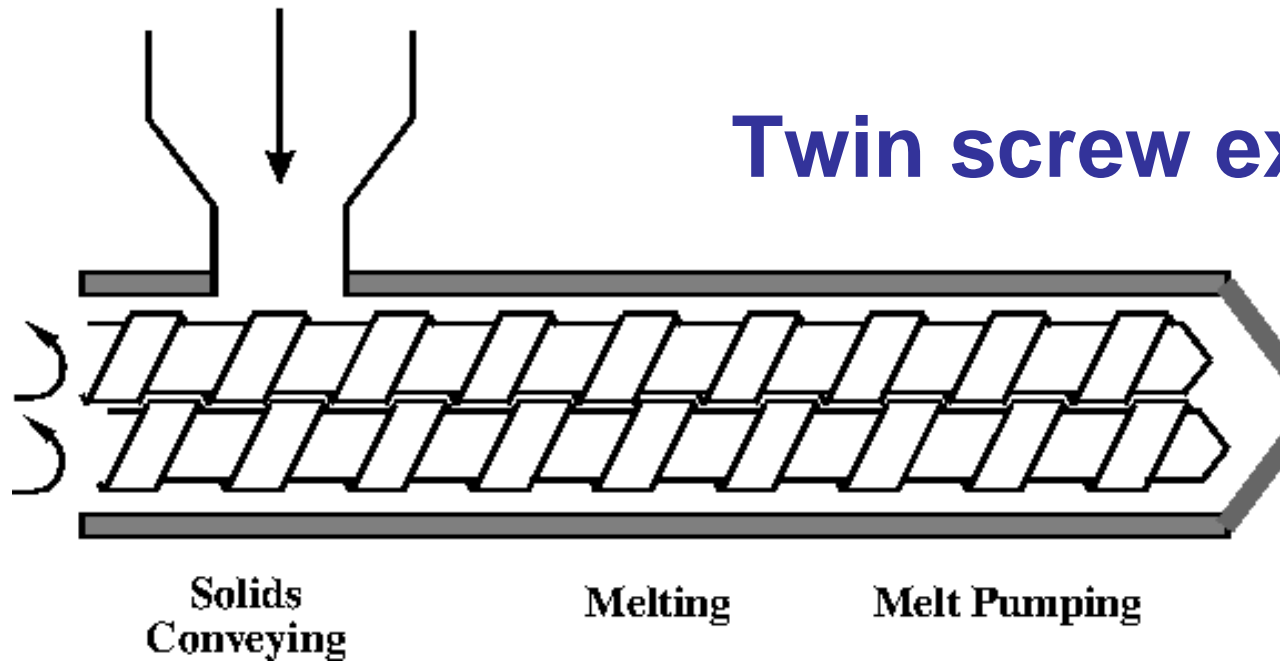

-screw has one or two 'flights' spiraling along its length.

- ϕ to outside of the flight is constant along the length to allow the close fit in the barrel.

-core is of varying ϕ and so the spiraling channel varies in depth.

-in general, the channel depth \downarrow from feed end to die end \rightarrow pressure \uparrow

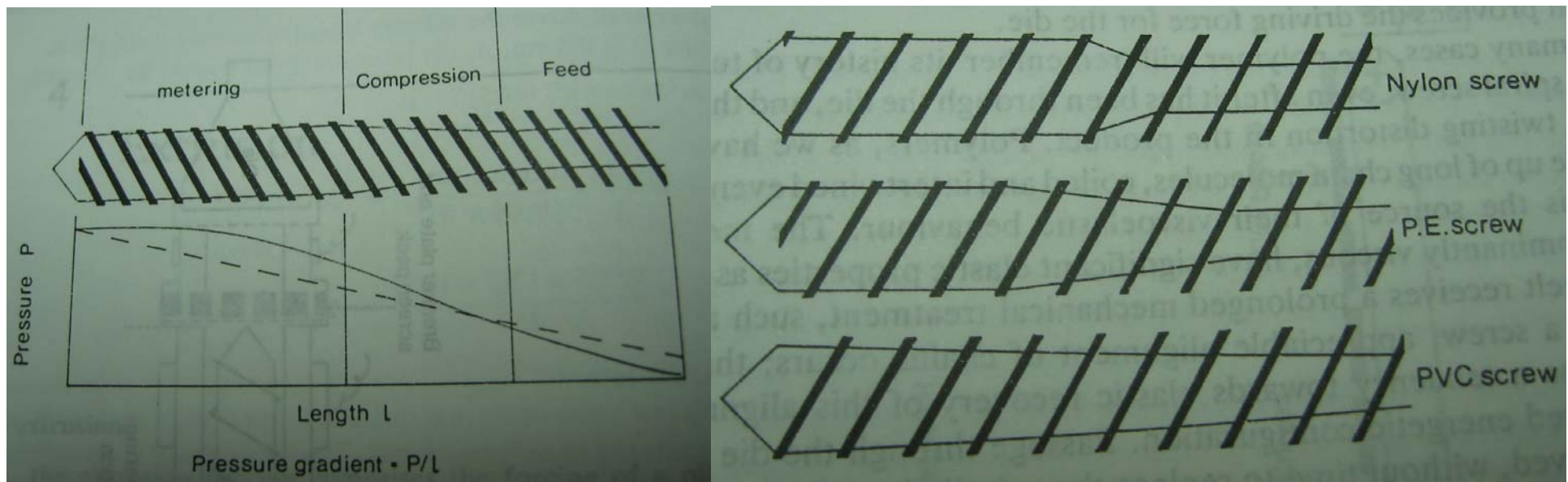

The zones in an extruder

1. Feed zone

- preheat polymer and convey it to the subsequent zones.**
- screw depth is constant**

2. Compression zone

- channel depth ↓**
- expel air trapped between original granules**
- heat transfer from the heated barrel walls is improved 'coz material thickness ↓**
- density change during melting is accommodated**
 - melt sharply → very short compression zone**
 - melt gradually → very long compression zone**

3. Metering zone

- constant screw depth**
- homogenize the melt**
- supply to the die region material which is of homogeneous quality at constant T & P**

4. Die zone

-breaker plate - screen pack (perforated steel plate)

a) sieve out extraneous material, e.g. ungeled polymer, dirt and foreign bodies

b) allow head P to develop by providing a resistance for the pumping action of the metering zone

c) remove 'turning memory' from the melt

Flow mechanisms: Conveying

-Drag flow

- dragging along by the screw of the melt as the result of the frictional forces
- equivalent to viscous drag between stationary and moving plates separated by a viscous medium.
- constitute output component for the extruder.

-Pressure flow

- P gradient along the extruder (high P at the output end, low at the feed end)

-Leak flow

- finite space between screw and barrel through which material can leak backwards.

$$\textbf{Total flow = drag flow – pressure flow – leak flow}$$

The extrusion die

1. Basic flow patterns

Maintain laminar flow

2. Die entry effects

Tensile stress exceed the tensile strength of the melt

→ extrudate will be of irregular shape

→ called *melt fracture*

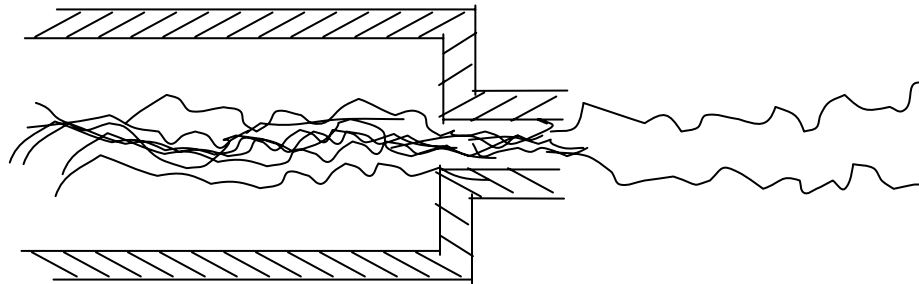

The die entrance is tapered:

- 1. Eliminate the dead spots in the corners, maintaining a steady heat and shear history**
- 2. Minimize the development of tensile stresses, and minimize distortion of the streamlines**

Long die land → extend the process time which helps to eliminate memory of earlier processing, e.g. screw turning memory

Deborah Number, N_{deb}^*

Relaxation time – the characteristic timescale for which a melt has memory

-describe as its viscous and elastic responses to an applied stress

$$\textit{relaxation_time} = \frac{\textit{viscosity}}{\textit{modulus}} = \frac{Ns \times m^2}{m^2 \times N} = s$$

$$N_{deb} = \frac{\textit{relaxation_time_of_material,in_process}}{\textit{timescale_of_process}}$$

If $N_{deb} > 1$, process is dominantly elastic.

If $N_{deb} < 1$, process is predominantly viscous.

3. Die exit instabilities

sharkskin

-roughening of the surface of the extrudate

-caused by tensile stresses:

the melt, with max velocity at the center and zero at the wall, leaves the die lips

→ material at the wall accelerate to the velocity at which the extrudate is leaving the die

→ generate tensile stress.. If tensile stress exceeds tensile strength, surface ruptures.

orange peel

-when conditions become more intense, e.g. P at the extruder becomes excessive, or the die T drops

-coarser-grained appearance

bambooning

-the whole extrudate 'snaps back'

Extra heating of the die will often help to remedy these defects, by thermally relaxing the stresses and lowering viscosity

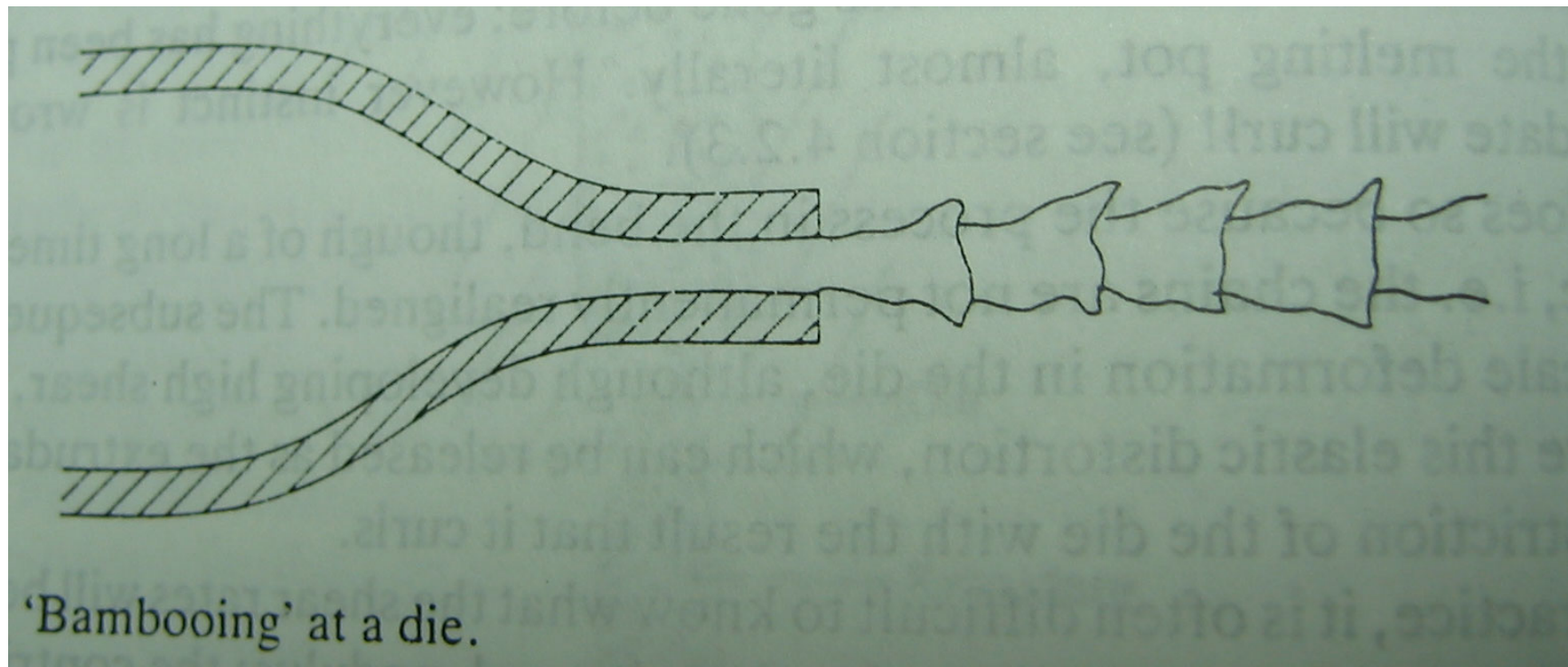

4. Die swell

- Effect in which the polymer swells as it leaves the die.
- Extrudate differs in its dimensions from those of the die orifice.
- Extruded rod has larger diameter and pipe has thicker walls, e.g. o.d. \uparrow , i.d. \downarrow

Result of the elastic component in the overall response of the polymer melt to stress. \rightarrow recovery of the elastic deformation as the extrudate leaves the constraint of the die channel and before it freezes.

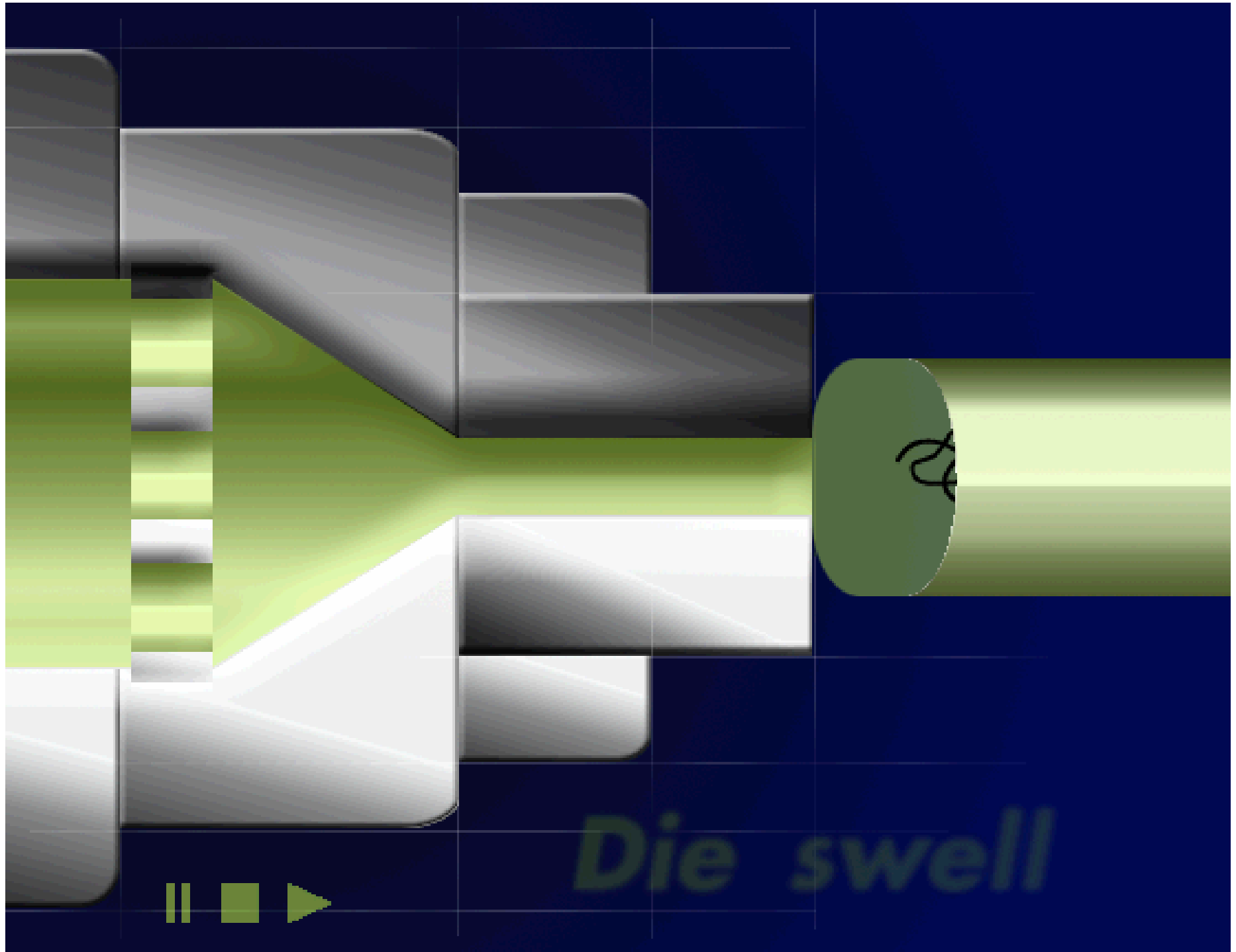

Die swell



Part Cost - low
Tool Cost - low
Production Capability - high
Short lead times to production
Uniform cross section of parts
Multiple materials are possible in the same part.

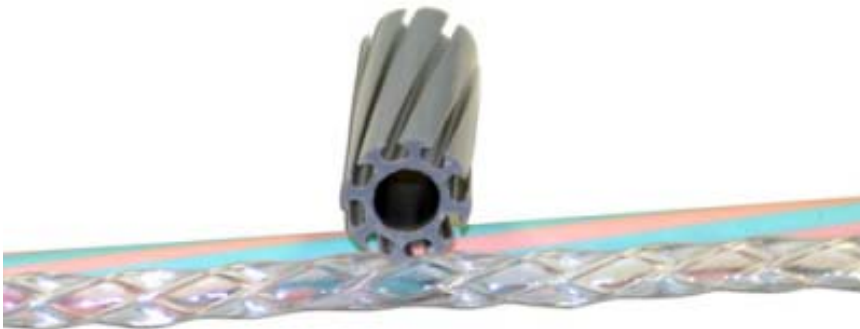

5. Extrusion-based processes

Profile extrusion: pipe, sheet

Tubular blown film extrusion: ถุงร้อน

Cross-head extrusion: สายเคเบิล

Synthetic fibers: เส้นใยสังเคราะห์ เช่น เส้นใยโพลีเอสเตอร์

Netting: ถุงใส่ผัก ผลไม้

Co-extrusion

Pipe extrusion

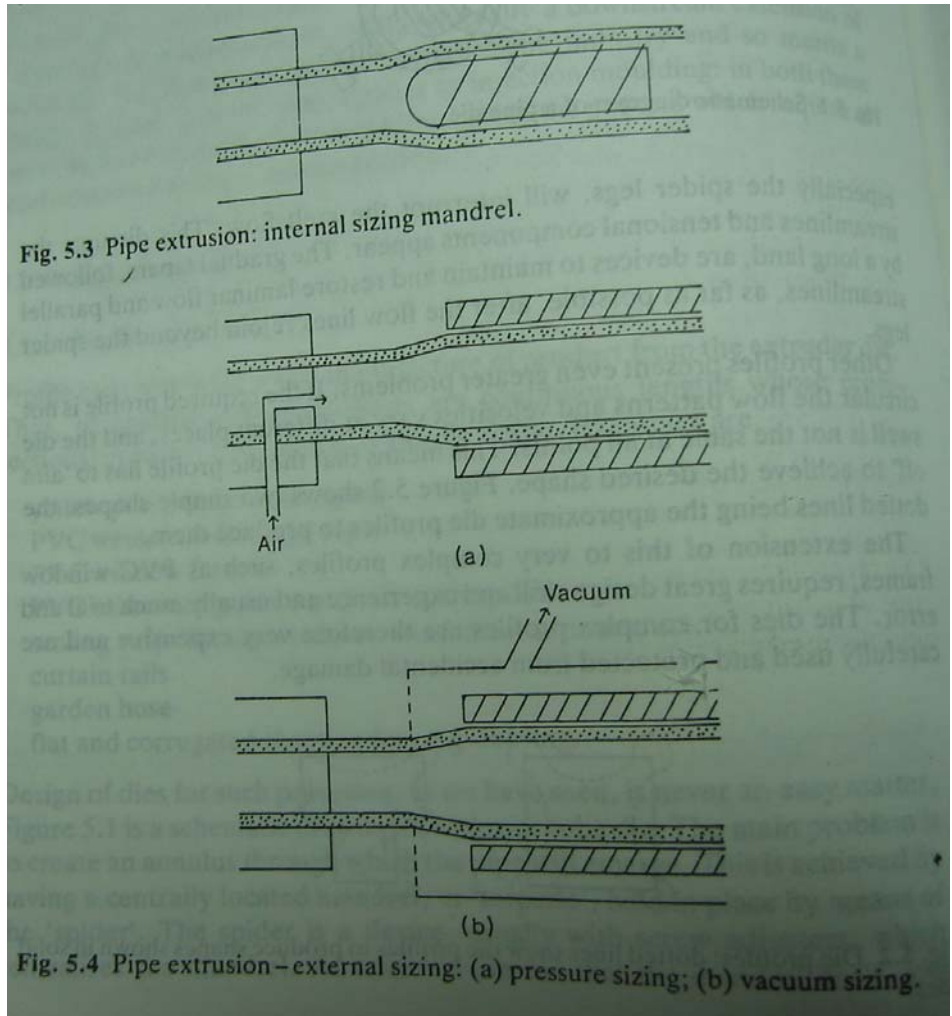
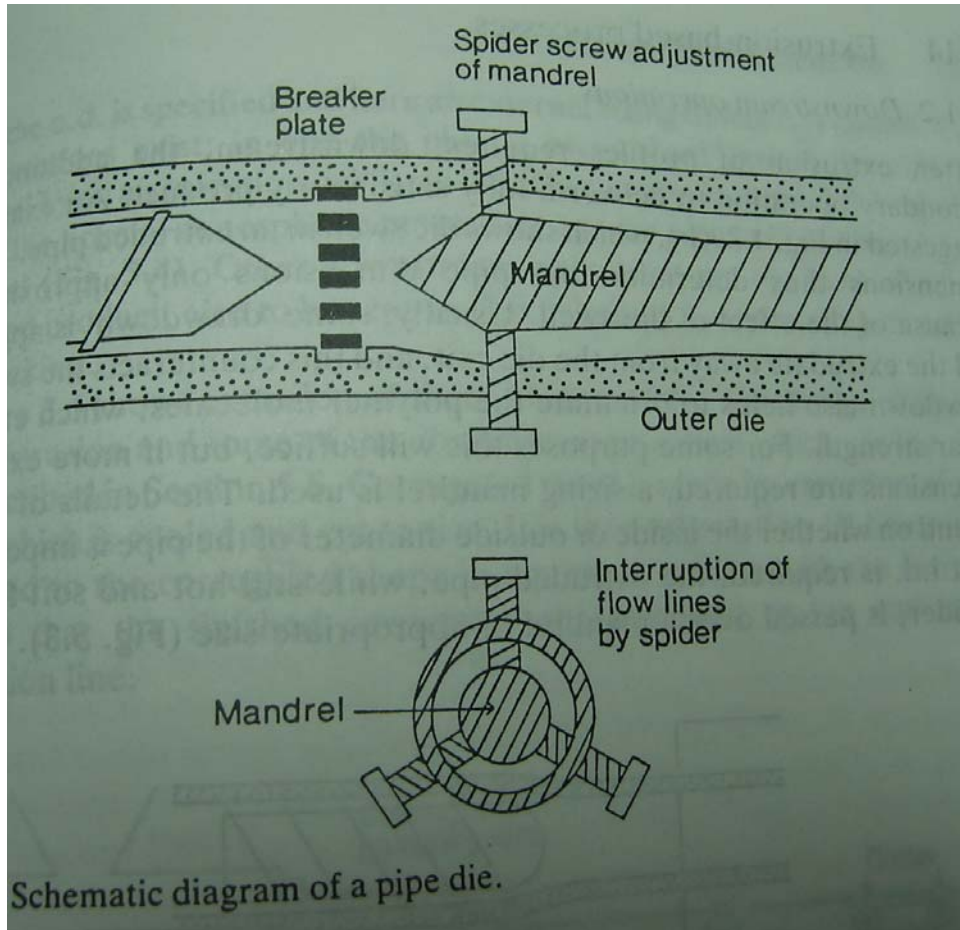

Sheet extrusion

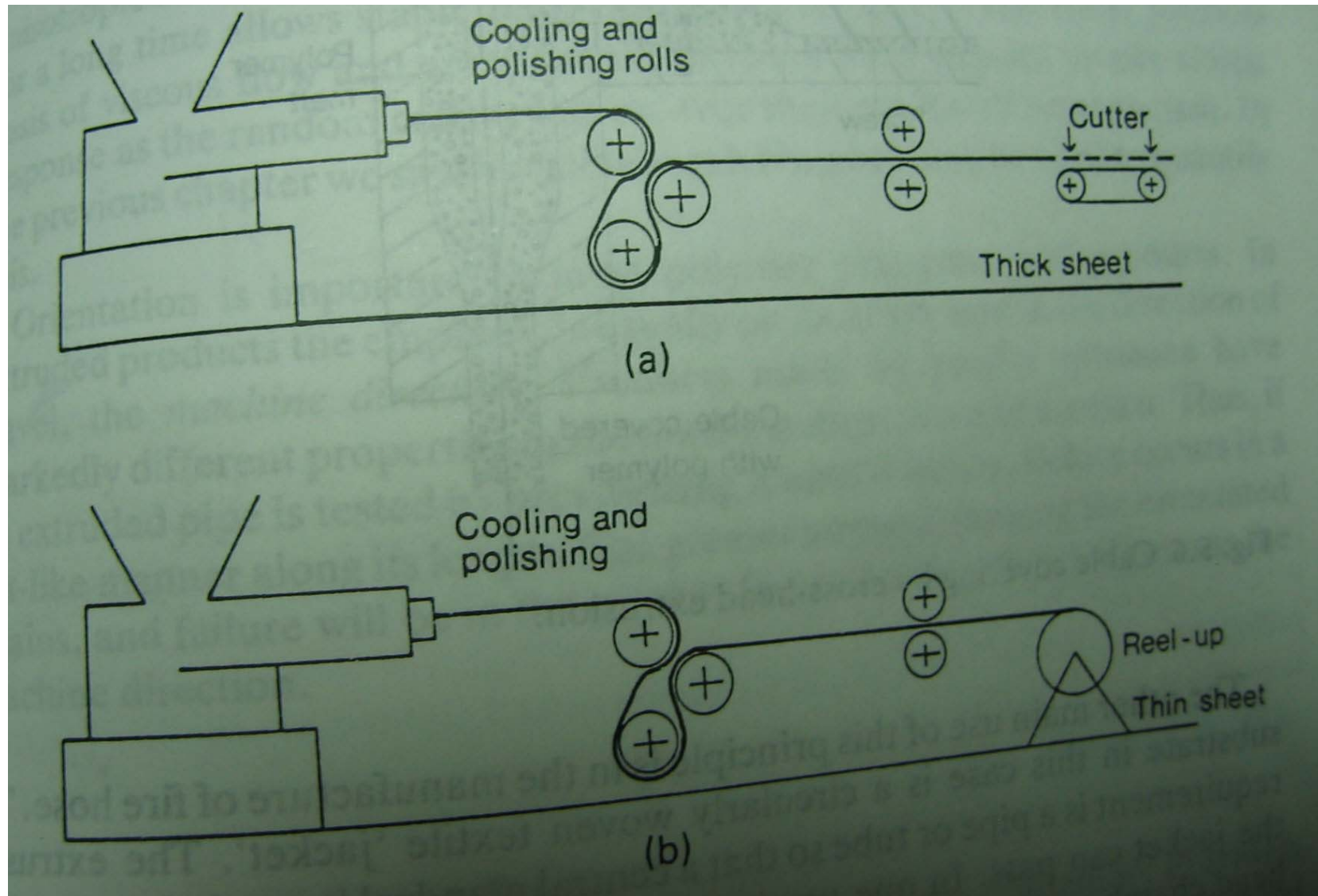

Film thickness: 0.5 – 20 mil (1 mil = 0.001 inch)

Tubular blown film extrusion

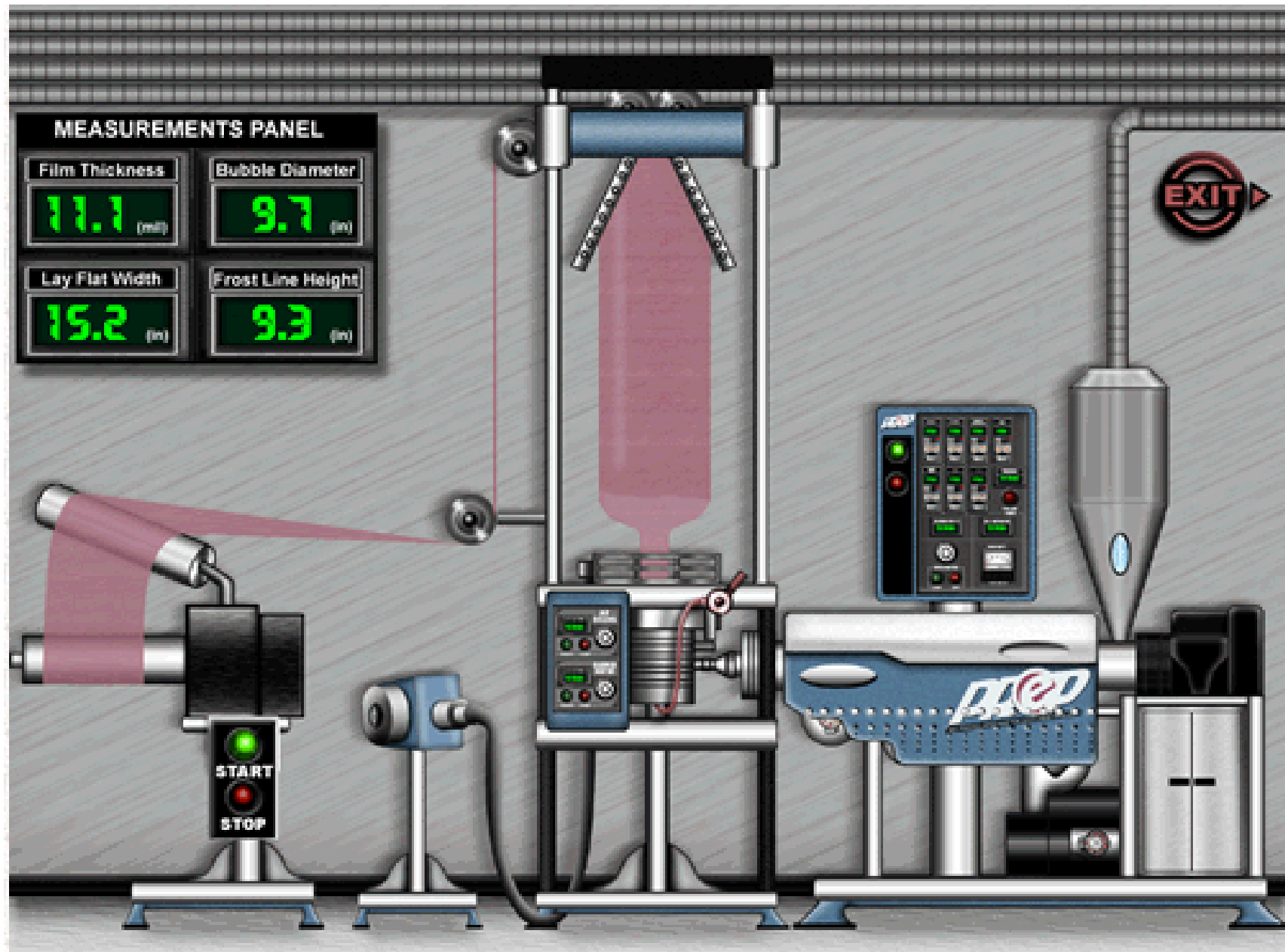

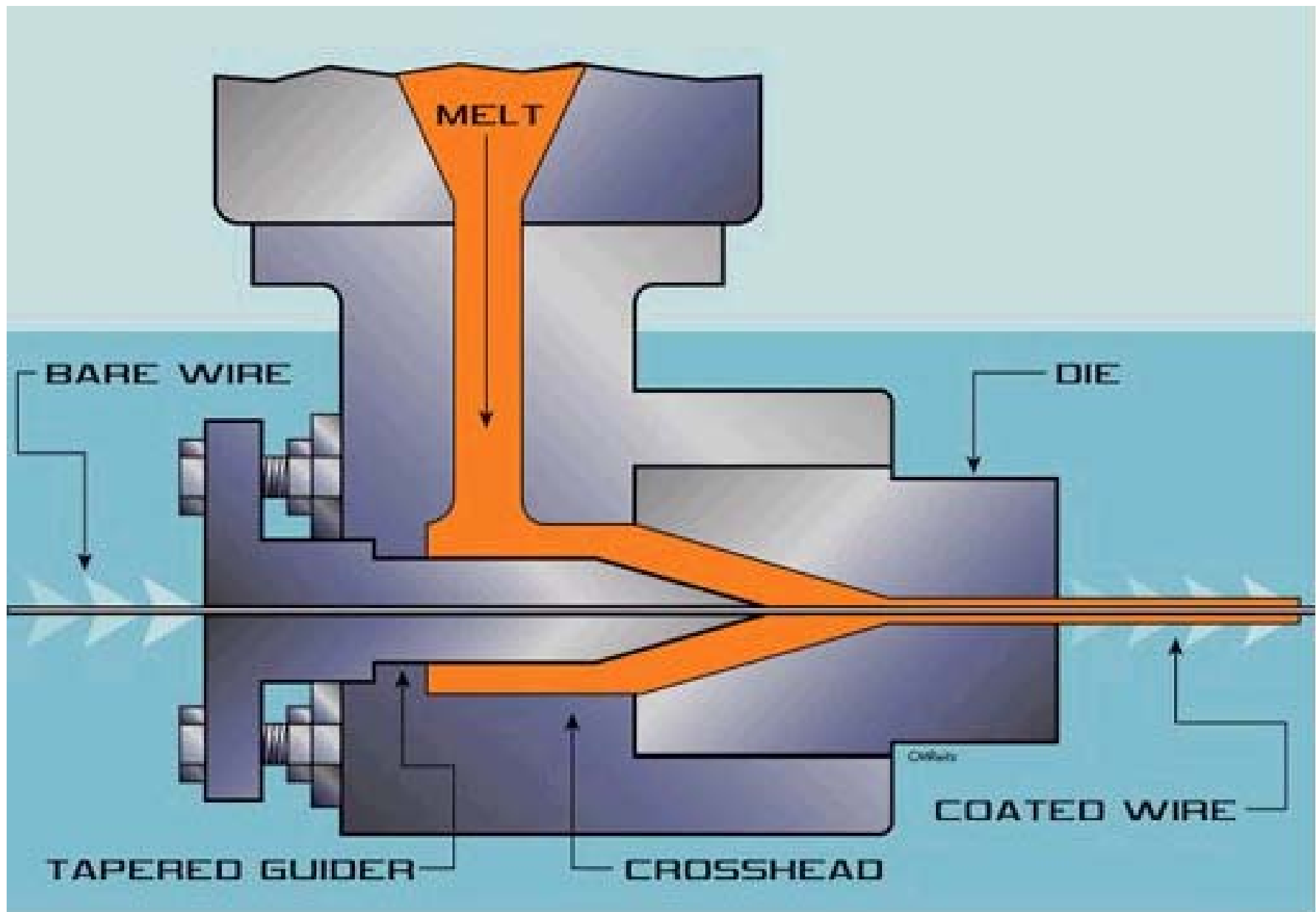

WIRE COATING IN MELT

SPINNERET

PLASTIC SOLIDIFIES AS
HEAT ENERGY IS LOST

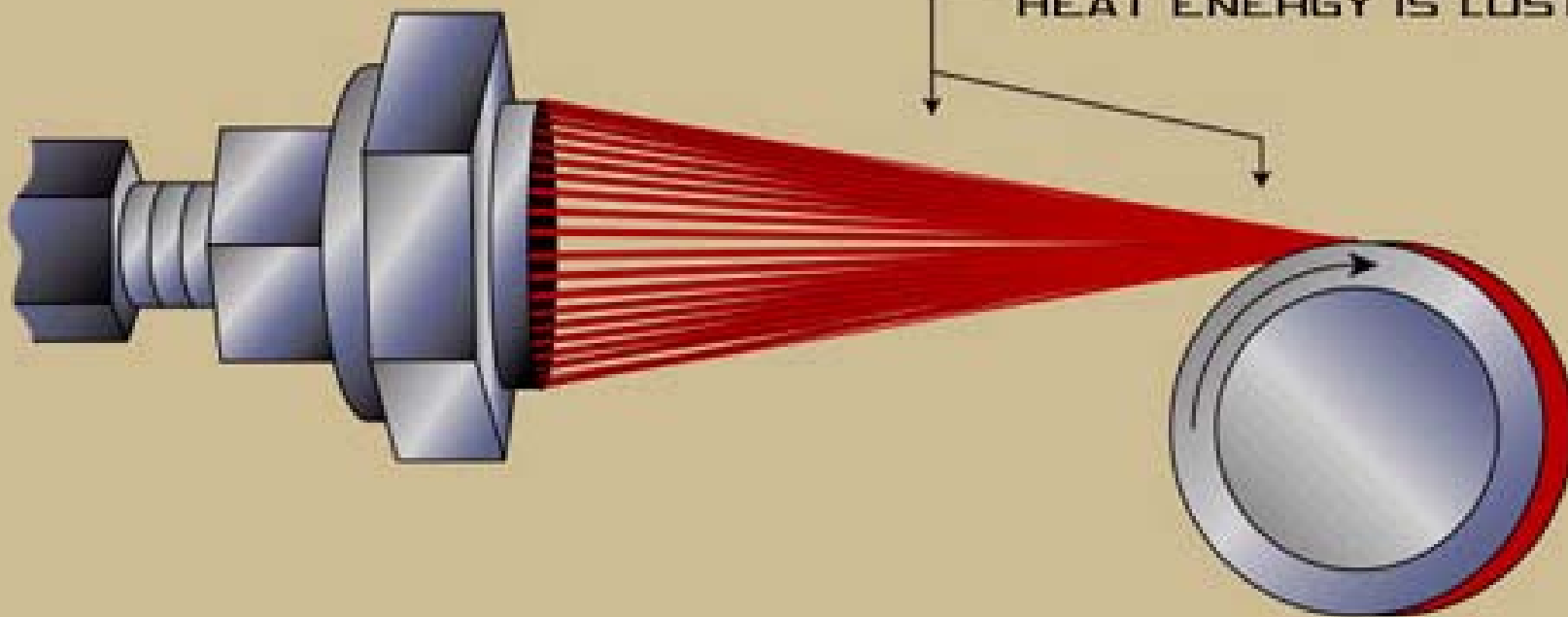

A MELT SPINNING

Plastic



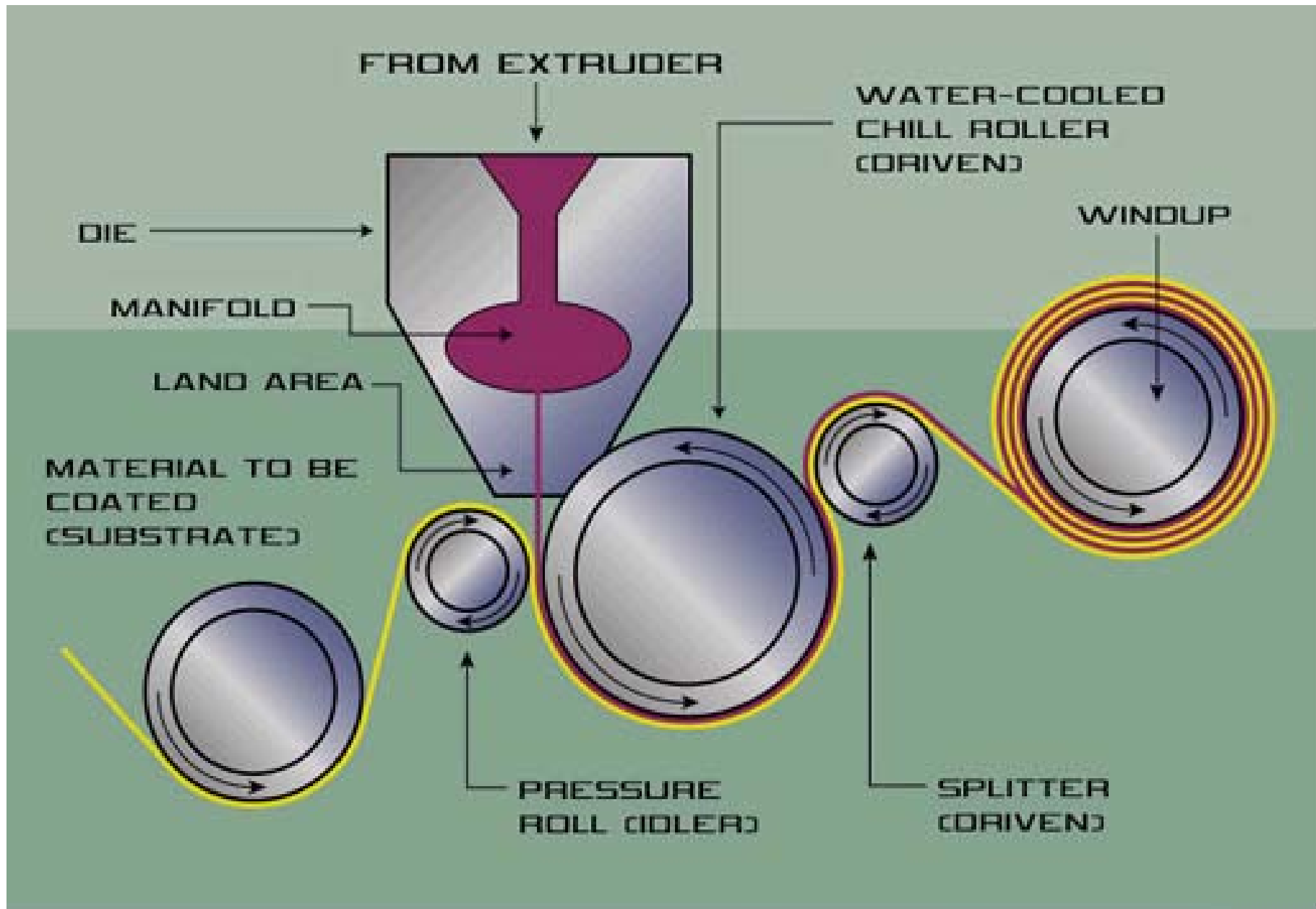

SUBSTRATE COATING

Plastic	Substrate
	

Netting

- Garden uses, fruit packaging**
- Made with annular dies but with outer die and the central mandrel counter-rotating and close fitting**
- Both parts have slots so that concentric sets of filaments extrude**
- When counter-rotation starts the filaments cross one another to form welded junctions and a net pattern.**

Co-extrusion

- Extrusion of more than one type of polymer at once to give a laminate product.**
- Require a separate extruder for each polymer**
- Multilayer product forming at a die**
- ‘tie-layers’: bond the functional layers together**

Multi-Layer ... Mono Material

For non-demanding applications, a mono material sheet is usually specified. This is a sheet in which there is only one material. With a more demanding application, a multi-layer sheet is used. Multi head extruders feed into the extrusion die with the differing materials.

Multi layer sheeting, with a heat compliant top layer, can used to make heat-sealed applications. PVC / PE for Meat Trays, and CPET / APET for Meat Trays and Ready Meals.

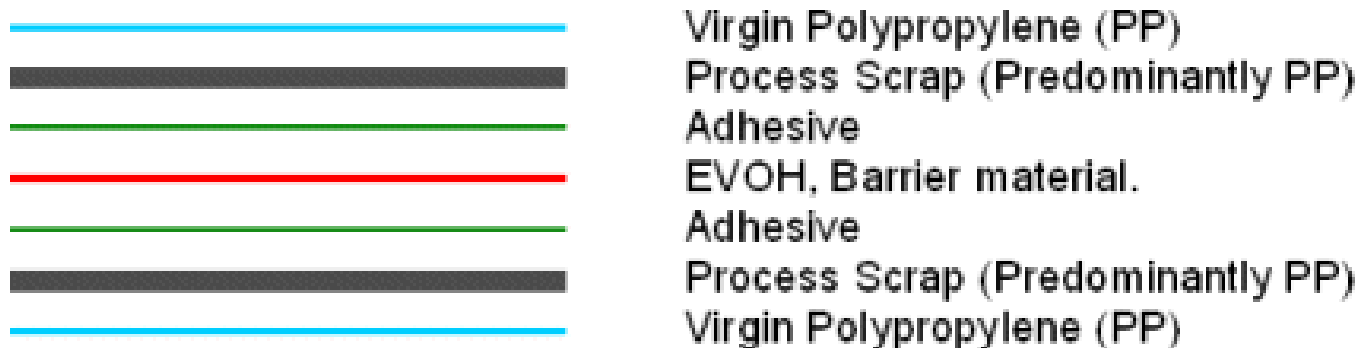

6. Injection molding

Injection molding is accomplished by forcing molten plastic under pressure into a cavity formed between two matched metal mold halves. Once the plastic cools, the molds are opened and the part is removed.

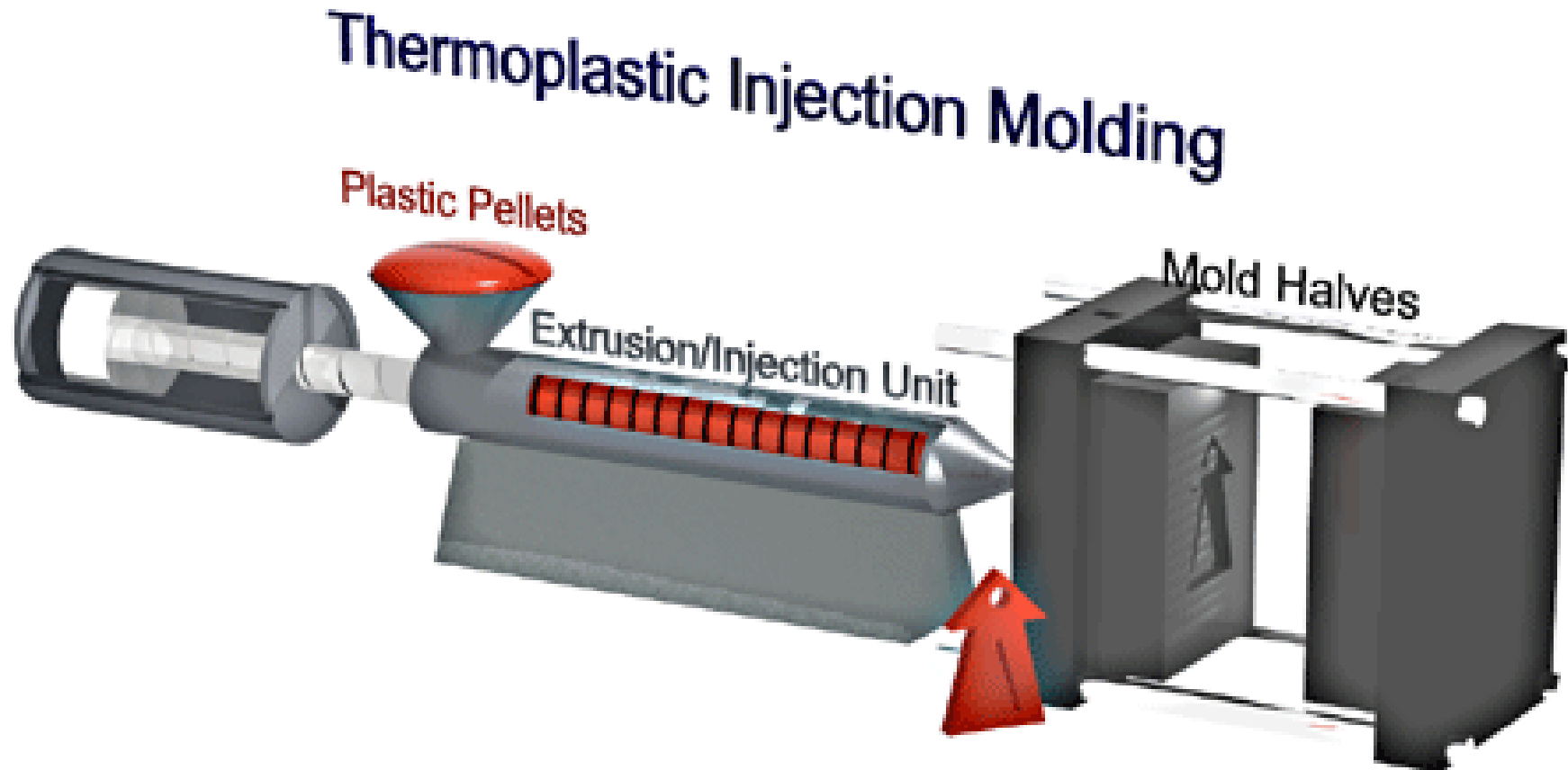

- Part cost - low**
- Tooling cost - high**
- Production Rate - high**
- Can produce intricate parts**
- Large variety of polymers gives wide range of properties.**
- Can produce a wide range of part sizes with different press sizes.**





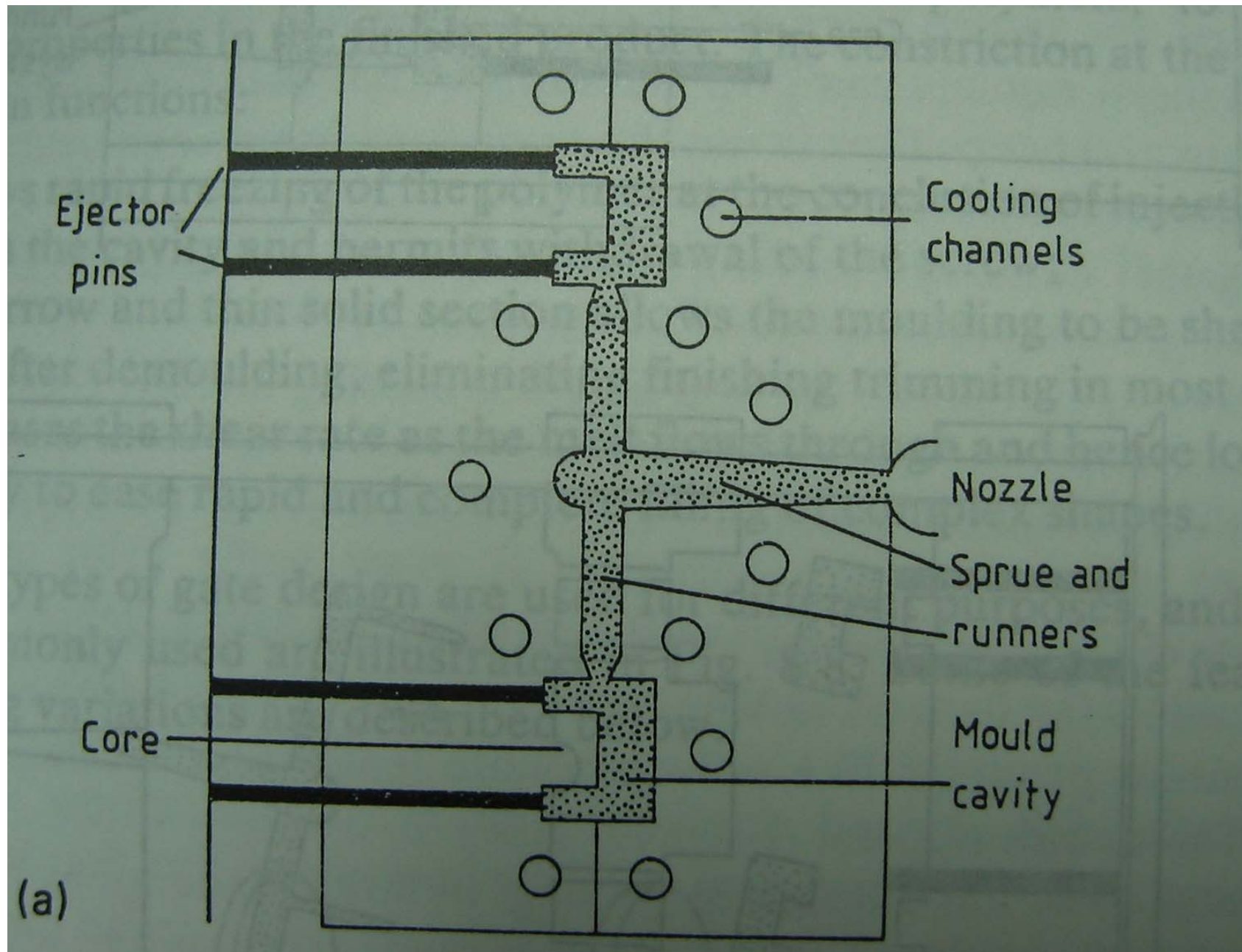

mold

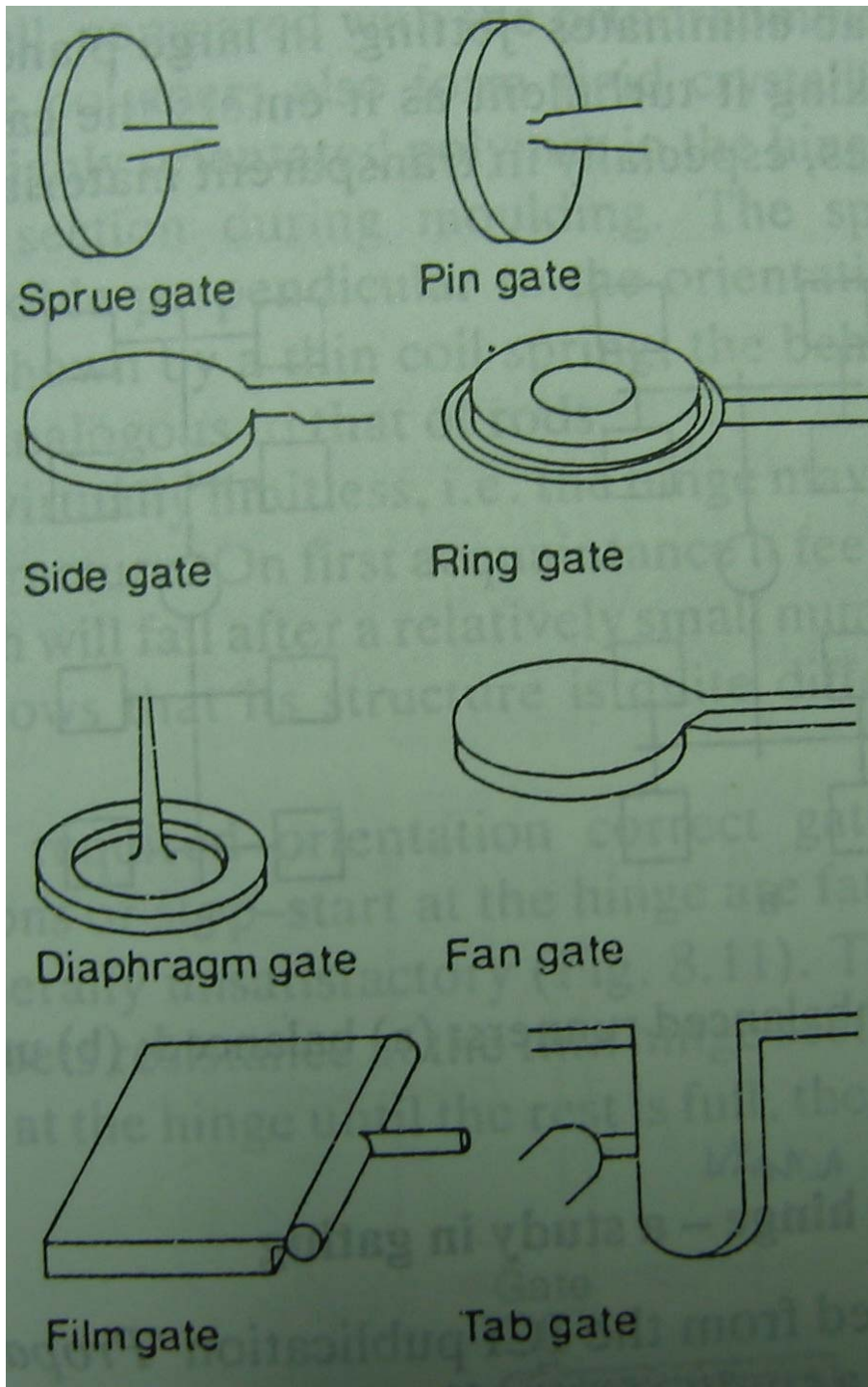

Functions:

- 1. Allow rapid freezing of polymer: isolate the cavity and permits withdrawal of the screw**
- 2. Narrow and thin solid section: be sheared off easily after demolding**
- 3. Increase shear rates as melt flows through: lower viscosity to ease rapid and complete filling of complex shapes**

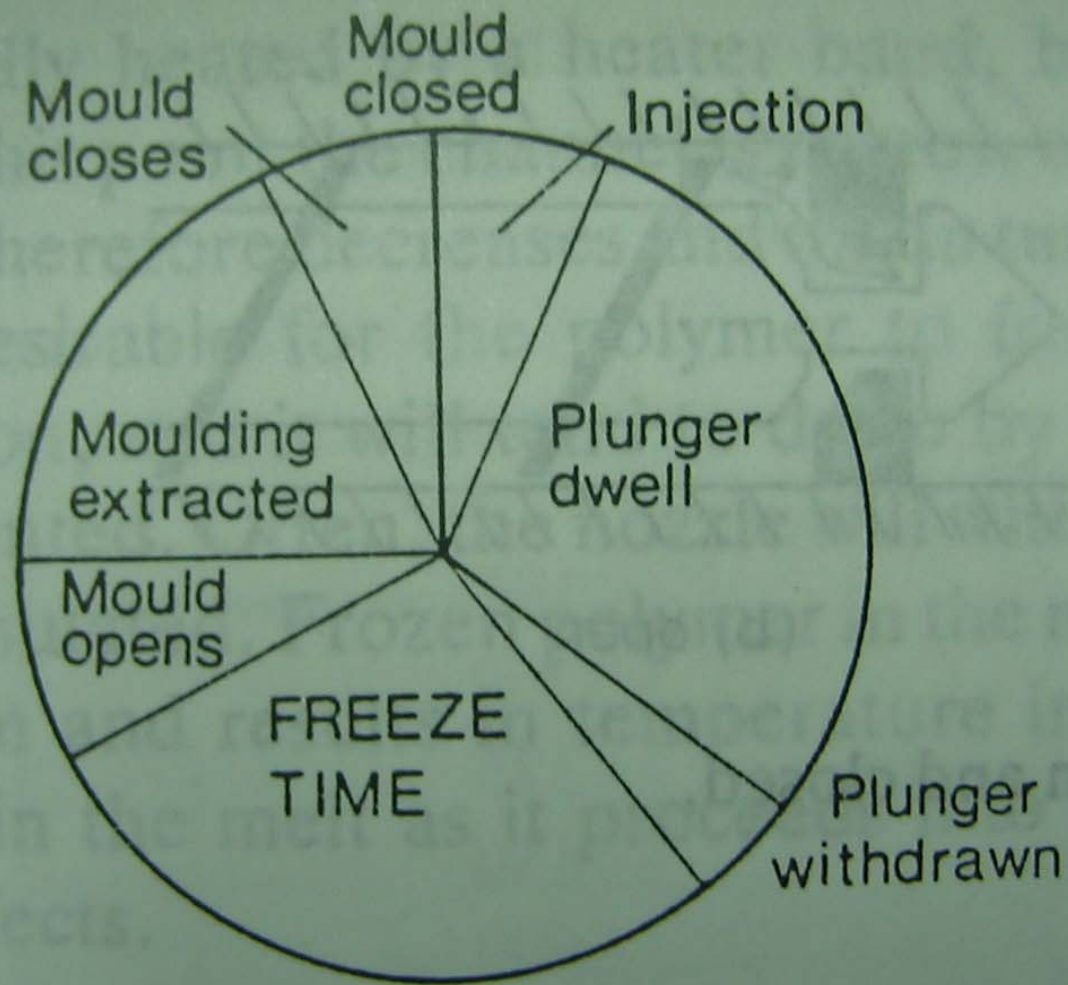

Cycle of operations for the production of injection mouldings.

Injection Mould

BPF

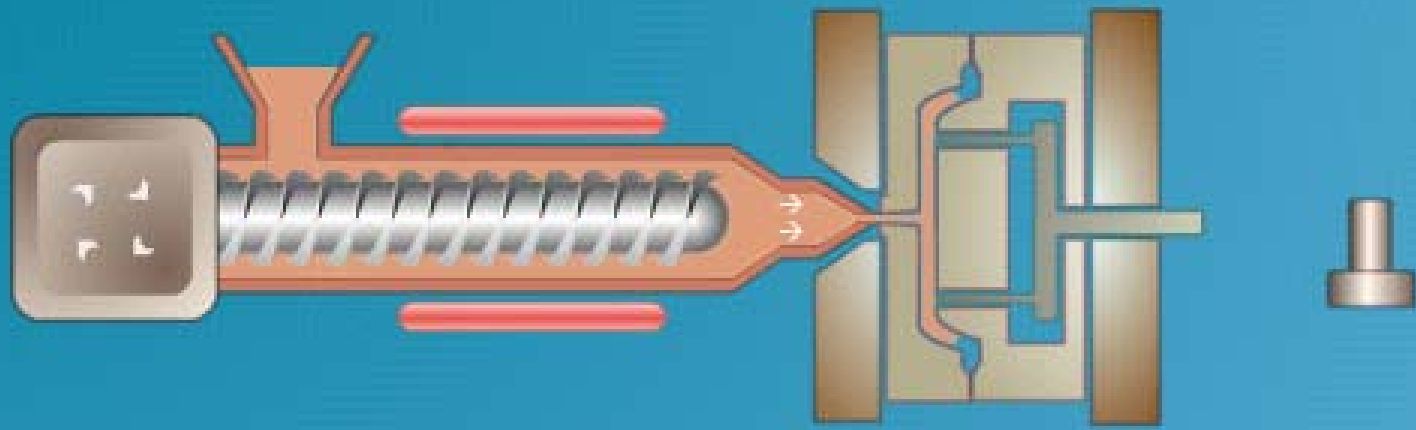

SLOW 

Problems:

-sink marks and voids

-weld lines

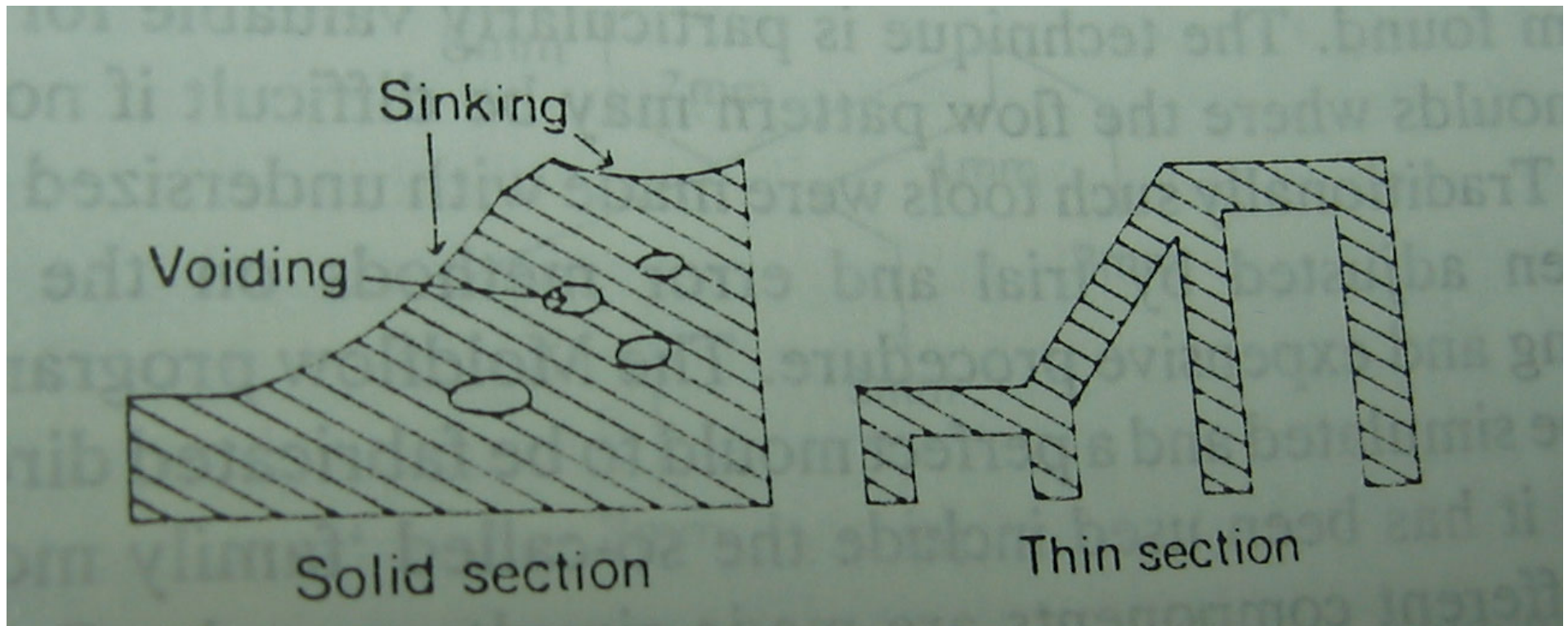

SINK

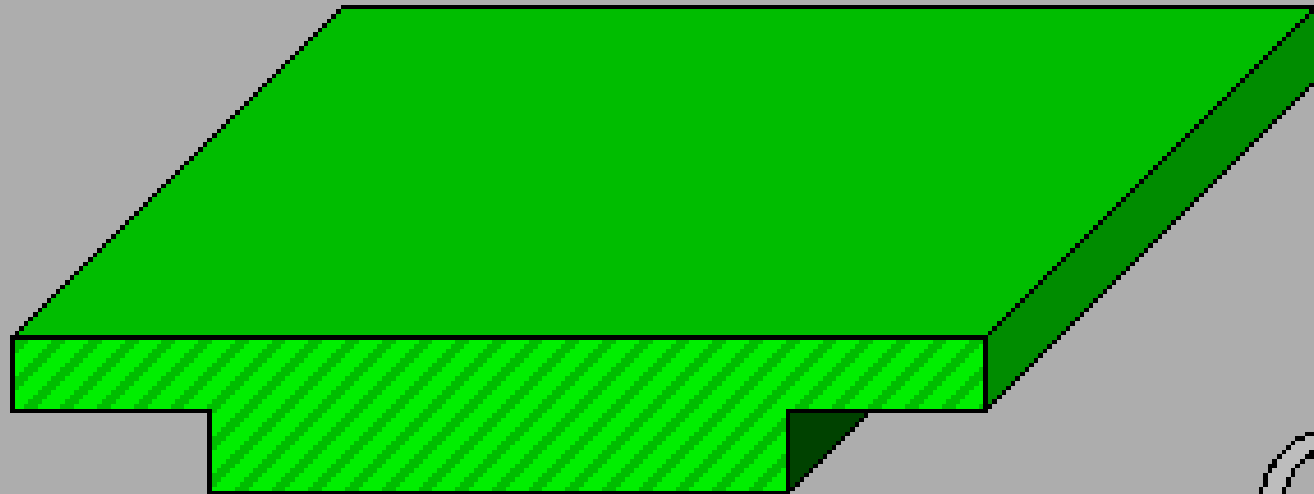

HOT

COOL

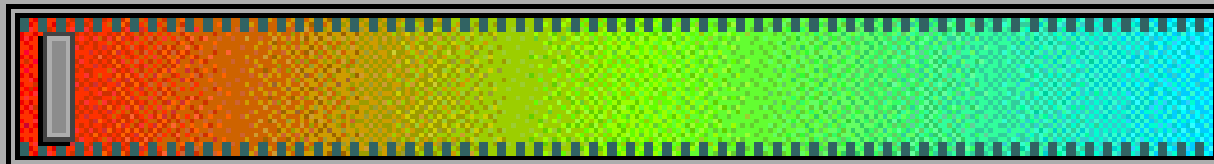

Part Temperature

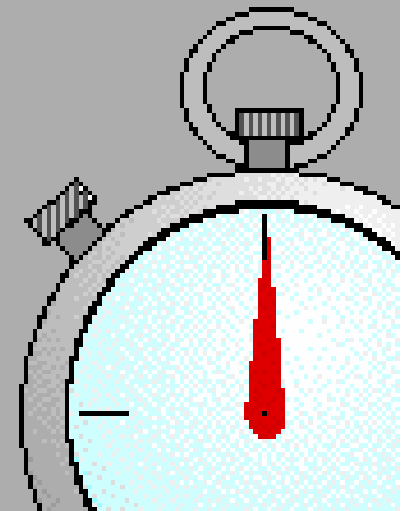

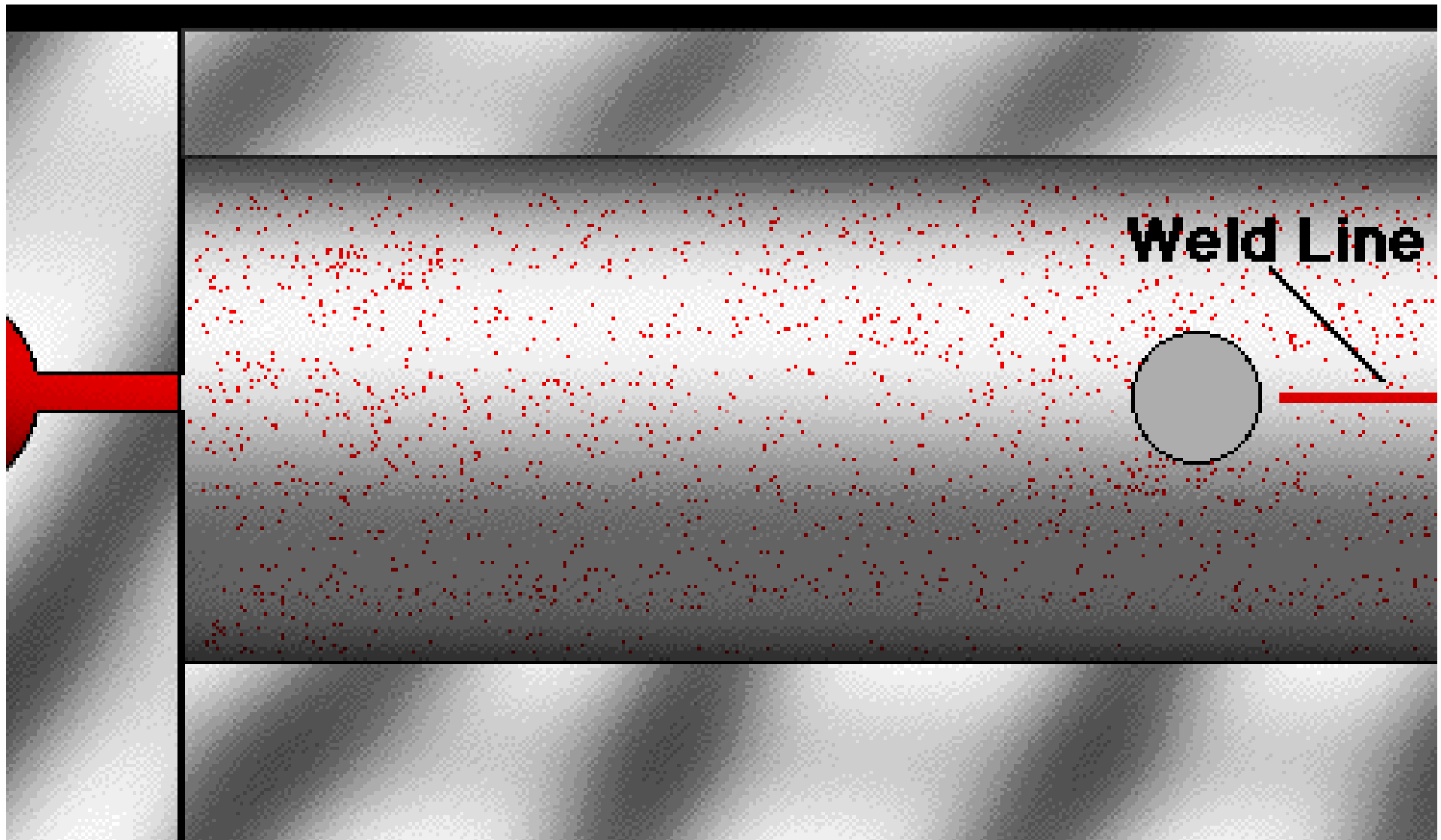

Weld line: formed where polymer flows meet

Can be moved to a position on the molding where unimportant

7. Blow molding

Extrusion blow molding

‘parison’

Thermoplastic Blow Molding

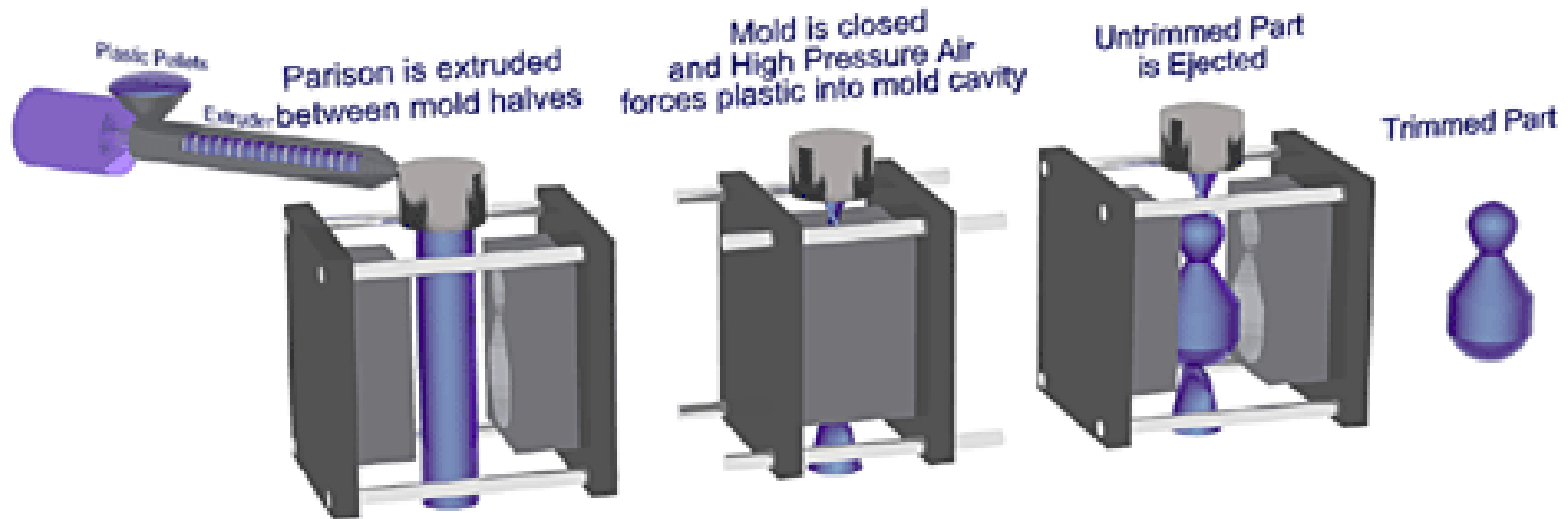

ขวดน้ำเปล่า สีขาวขุ่น ทำจาก **PP**

Extrusion blow molding

Typical products

Bottles and containers

Automotive fuel tanks

Venting ducts

Watering cans



- Part cost - moderate**
- Tooling Cost - moderate**
- Production rate - moderate to high**
- Blow molding produces parts with the highest strength to weight ratio of any plastic process. Complex, hollow parts are formed with no internal stresses. Parts as large as 12 ft. x 4 ft. x 4 ft. can be formed**



Stages

1. The hot plastic extruded into the mold in pipe form.
2. While still hot, the plastic is trapped in the mold, a hot knife cuts it off at the top and it is also pinched at the bottom.
3. The mold then moves to the right. An air hose is inserted into the top.
4. The plastic in the mold expands to fill the mold.
5. The mold then separates, which releases the plastic (bottle).

BPF

Extrusion Blow Moulding

RPC
GROUP PLC

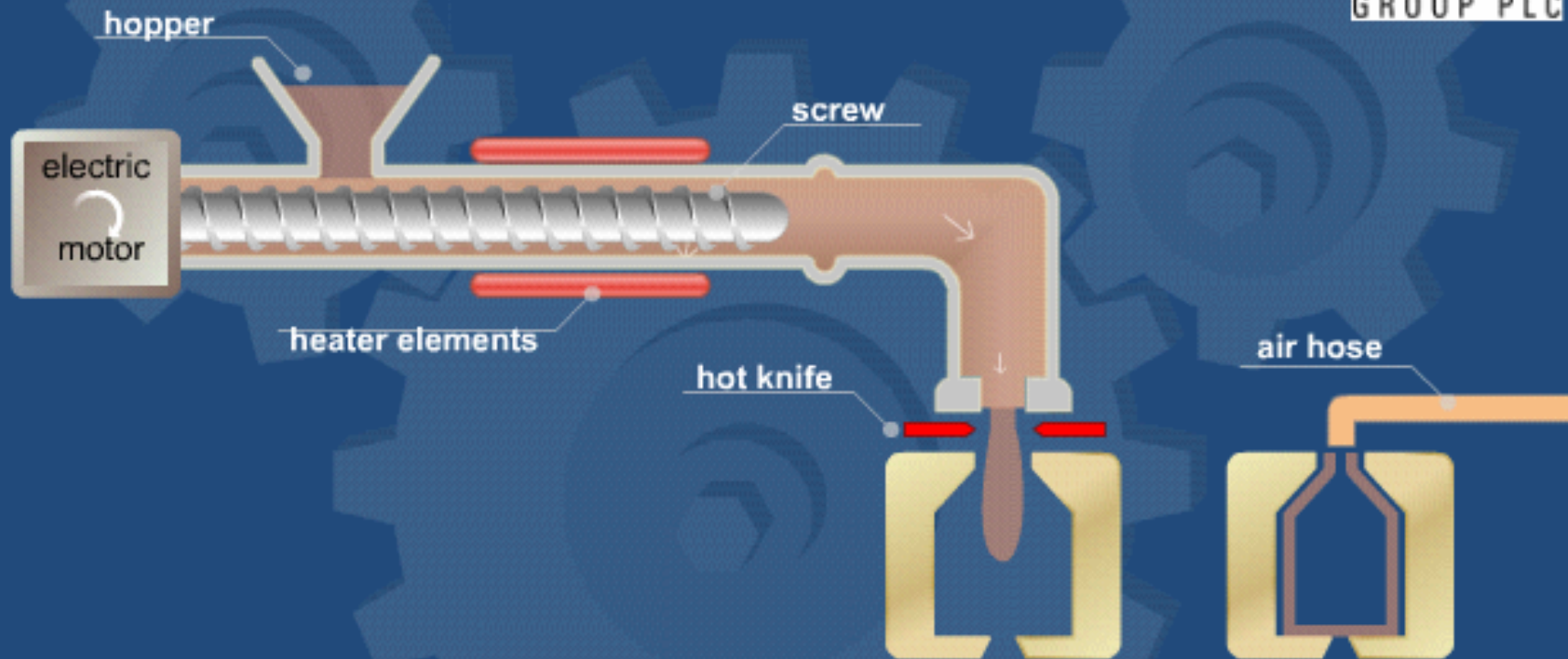

info

stages

Injection blow molding

Carbonated drinks → using PET

The tube → 'preform' made by injection molding to a very cold mold to quench it in its amorphous state

Is reheated to blowing T (just about its T_g) and stretch blown

Develop biaxial orientation in the product

Alternate name for this process is 'stretch-blow'

Injection blow molding

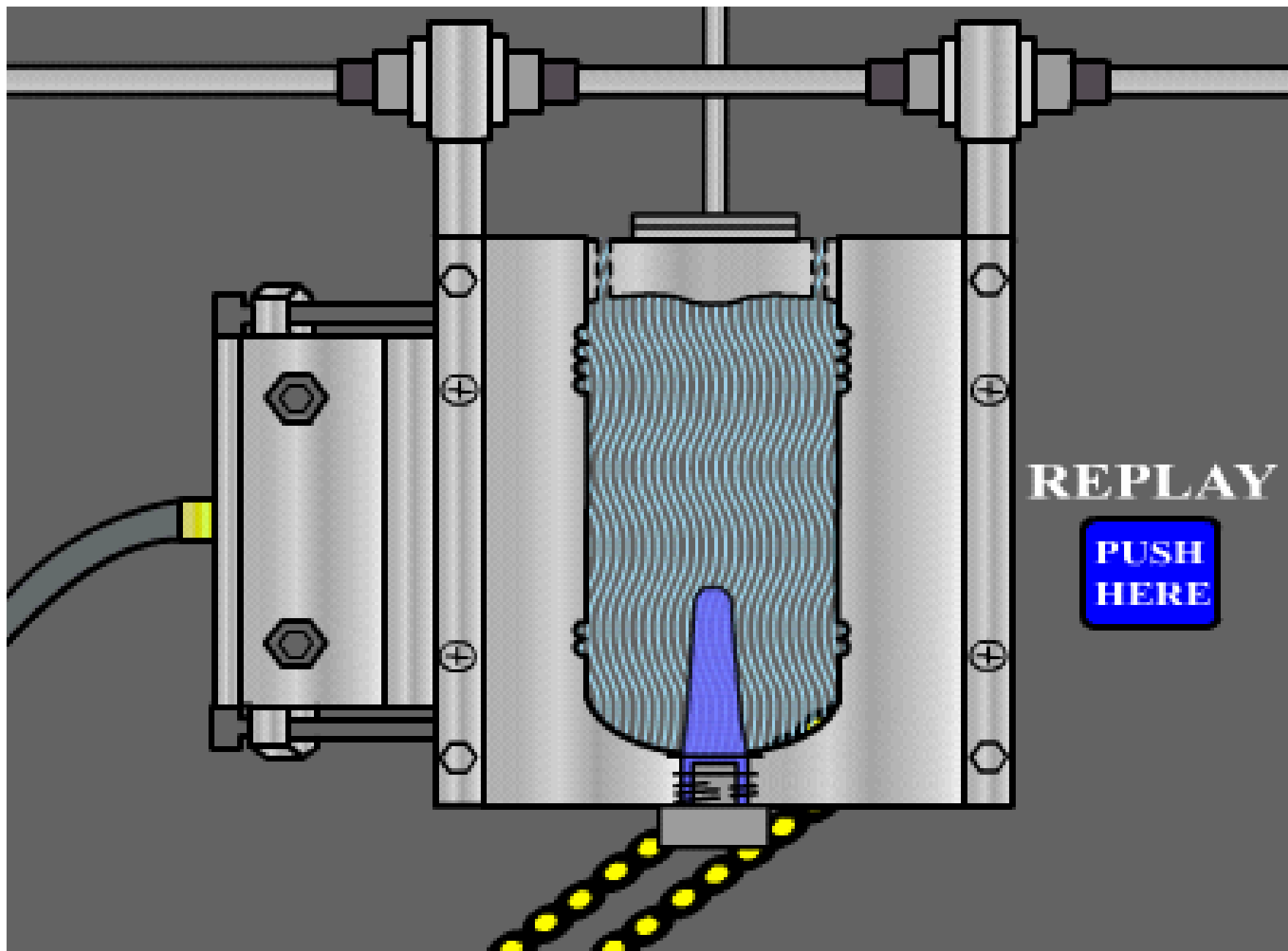

8. Plastic foam molding

- low-pressure injection molding process that is capable of producing very large structural parts.**
- The molten plastic material is injected into a mold after being mixed with a blowing agent or high-pressure gas.**
- This produces bubbles in the plastic causing it to foam. The foam retains the properties of the plastic but weighs less because of reduced density.**

Multi-Nozzle Low Pressure Structural Foam

