

# CHAPTER 7

## AIRCRAFT POWER PLANTS

All naval aircraft are engine driven. The early engines were all reciprocating engines. Today, almost all are jet propulsion engines. Therefore, this chapter covers only jet propulsion engines.

The jet propulsion principle is the basic concept for the gas turbine engine. This principle is not a new concept. Sea creatures use jet propulsion to propel themselves through the water. The Egyptians built the first reaction engine around 250 BC. Between 1700 and 1930, technical achievements in engineering, manufacturing, and metallurgy made the reaction principle applicable to the development of the gas turbine engine for jet propulsion. In 1939, the Germans flew the first aircraft powered by a gas turbine engine, followed by the British in 1941, and the Americans in 1942. During World War II, Germany was the only nation to fly a gas turbine-propelled aircraft in actual combat.

There are two types of jet propulsion engines: the rocket, and the gas turbine engine. Of these, the gas turbine engine powers almost all naval aircraft. There are four types of gas turbine engines: the turbojet, the turbofan, the turboprop, and the turboshaft. The turbojet and turbofan engines use thrust directly. The turboprop and turboshaft engines use thrust to deliver torque (turning power) to an airplane propeller or a helicopter rotor. Regardless of the type, the purpose of an engine is to develop thrust. This chapter will give you basic information on jet propulsion engines.

### LEARNING OBJECTIVE

When you have completed this chapter, you will be able to do the following:

1. Explain the basic operating principles of jet propulsion engines, and identify the components and functions of each type of engine.
2. Define the Brayton cycle and its application to gas turbine and jet engines.
3. Identify the two engine designation systems to include symbols, numbers, indicators, and special designators.
4. State power plant safety precautions that apply to the intake ducts, exhaust area, and engine noise.

### JET PROPULSION ENGINES

A jet propulsion engine projects a column of air to the rear at extremely high speeds. The resulting thrust pushes the aircraft in the opposite (or forward) direction. Jet propulsion engines are grouped into two main types:

1. Rocket. These are jet propulsion systems that do not use atmospheric air.
2. Gas turbine. The gas turbine engine operates as a continuous turbine-compressor unit.

## Rocket Engines

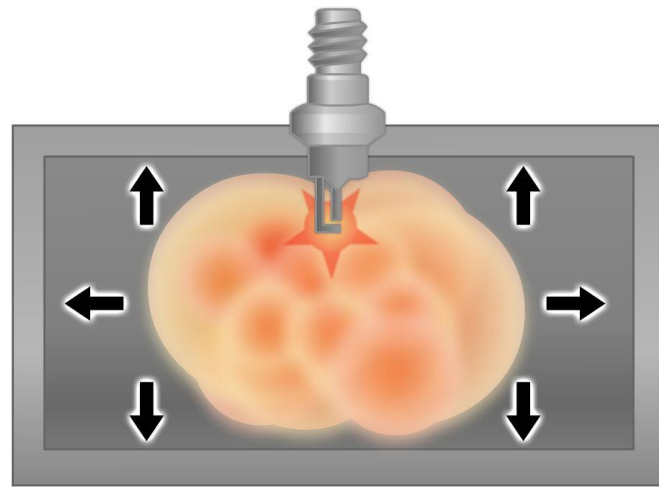
The rocket uses a form of jet propulsion that differs in basic ways from thermal gas turbine systems. The rocket does not draw air from the outside to fuel the combustion process. It carries with it both the fuel and the oxidizer for combustion. This design is a disadvantage for atmospheric flight, but it is the only way at present to fuel flight outside the earth's atmosphere. The rocket is a true jet reaction unit. A brief examination of its functions clarifies the reaction principle by which all thermal jet units operate.

If you burn a hydrocarbon (compound containing only hydrogen and carbon) in a closed container, the heat of the burning fuel is released, causing the trapped gases to expand rapidly (see *Figure 7-1*). Because the container has a closed volume, the temperature and pressure rises and is uniformly distributed (balanced) in all directions. Since the force of the rising pressure cannot be released and is balanced, the container does not move.

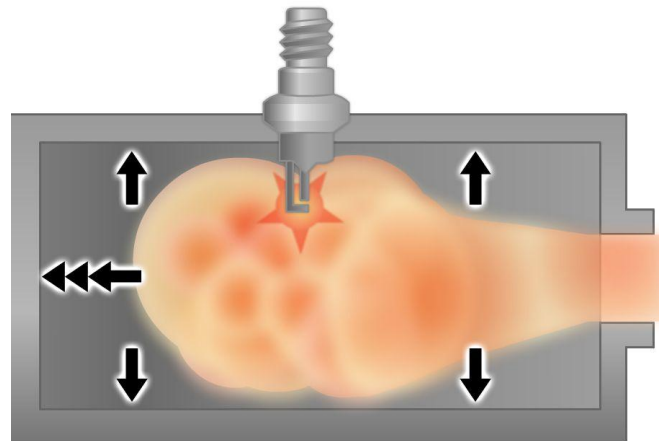
When you burn fuel in a container that has an opening (or nozzle) at one end, expanding gases rush out of the nozzle at a high velocity, as shown in *Figure 7-2*. Releasing internal pressure at the nozzle end of the container leaves an unbalanced pressure at the other end. The released pressure moves the container in the direction opposite to that of the escaping gases. This is the basic operating principle for all jet engines. Obviously, propulsion depends solely on internal conditions. The container does not "push against" external air. In fact, a complete vacuum would produce even greater force.

The jet propulsion engine operates like a toy balloon. Newton's third law of motion explains this operation. This law states, "For every acting force there is an equal and opposite reacting force." Inflate a balloon. The air pressure inside the balloon, which is stretching the skin, is greater than the pressure outside the balloon. If the stem is tied closed, the inside air pushes in all directions and the balloon will not move. Place the balloon in a vacuum and release the stem. The escaping air has nothing to push against, but the balloon will move in a direction away from the stem, just as it does in a normal atmosphere.

Releasing the stem removes a section of skin on the side of the balloon against which the air has been pushing. On the side directly opposite the stem, however, the air continues to push on an equal area of skin. The continued push of air on this area causes the balloon to move in the direction away from the stem.

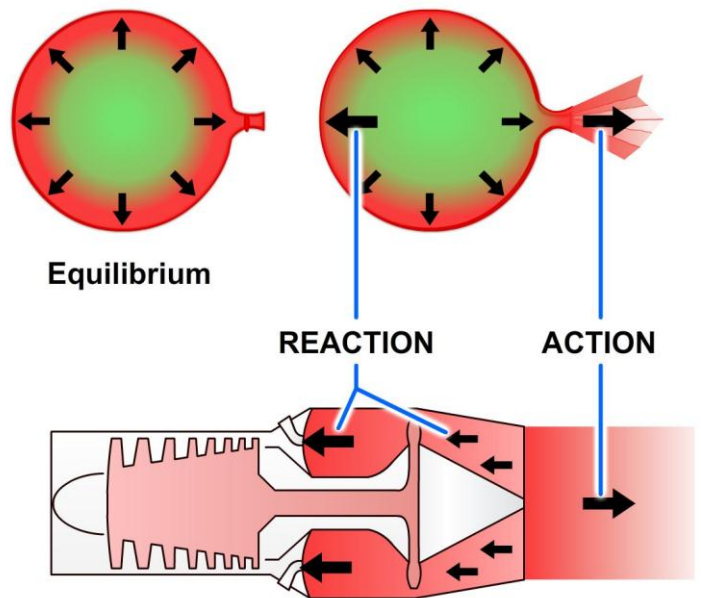


**Figure 7-1 — Combustion in a closed container.**



**Figure 7-2 — Principle of jet propulsion.**

The acting force that Newton's third law refers to is the acceleration of the escaping air from the rear of the balloon. The reaction to this acceleration is a force in the opposite direction. In addition, the amount of force acting on the balloon is the product of the mass of air being accelerated times the acceleration of that air. Since the forces always occur in pairs, we can say that if a certain force is needed to accelerate a mass rearward, the reaction to this force is thrust in the opposite direction; force = thrust, as shown in *Figure 7-3*.



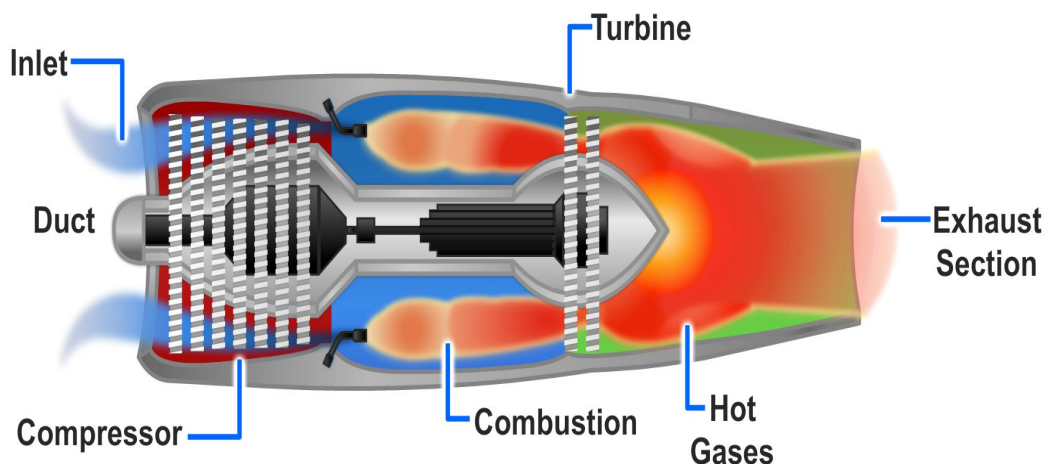
**Figure 7-3 — Balloon as a jet engine.**

## Gas Turbine Engines

As stated earlier, there are three types of gas turbine engines: turbojet, turboprop, and turboshaft. Each of these engines is briefly discussed in the following paragraphs.

### Turbojet Engines

There are different Navy models of the turbojet engine. The F/A-18 is an example of an aircraft that uses this direct thrust engine. The turbojet engine consists of five major components: an inlet duct, a compressor, a combustion chamber (or chambers), a turbine (or turbines), and an exhaust cone assembly, as shown in *Figure 7-4*.



**Figure 7-4 — Five major components of the turbojet.**

#### Inlet Duct

The inlet duct is an opening in the front of the aircraft that allows outside (ambient) air to enter the engine. The compressor compresses the incoming air and delivers it to the combustion (or burner) section. In the combustion chamber, fuel is sprayed into and mixed with the compressed air. An igniter then ignites the fuel-air mixture. The burning mixture continues to burn in the presence of the proper fuel-air mixture. The fuel-air mixture burns at a relatively constant pressure. Only about 25 percent of the air is used in the combustion process. The rest of the air (75 percent) is mixed with the combustion products (exhaust) for cooling before the gases enter the turbine section.

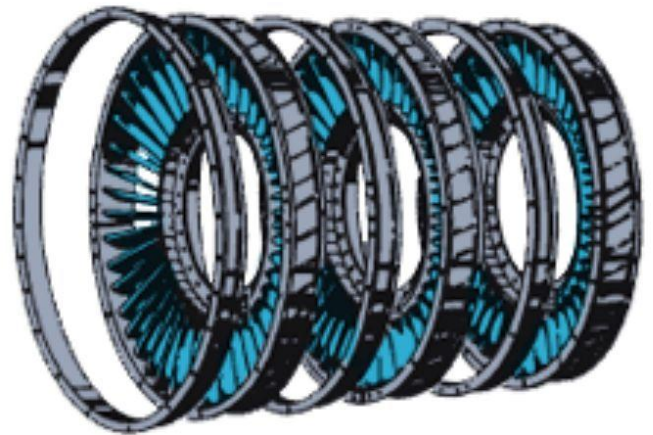
The turbine section extracts and uses a major portion of the energy in the gas stream to turn the compressor and accessories. After leaving the turbine, the remaining pressure forces the hot gases through the engine exhaust duct at very high speeds. The air that entered the inlet is now expelled at a much higher speed than when it entered. This occurrence causes the engine to thrust.

### Compressor

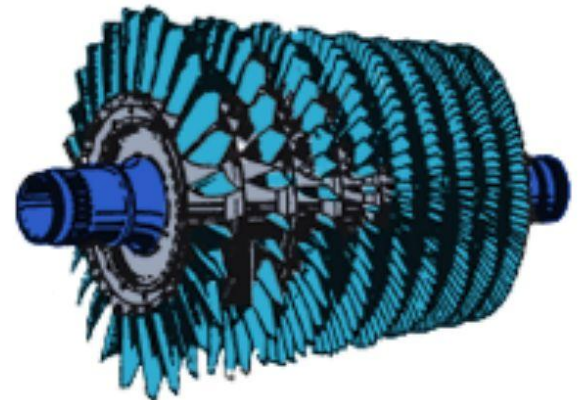
The axial-flow compressor is made up of a series of rotating blades and a row of stationary stator vanes, as shown in *Figure 7-5*. A row of rotating blades and stator vanes is called a stage. The entire compressor is made up of a series of alternating rotor blade and stator vane stages.

Recall that the compressor provides high-pressure air to the combustion chamber (or chambers). The compressor delivers outside (ambient) air to the inlet section and passes this air through the inlet guide vanes. In turn, the inlet guide vanes deflect the air in the direction of compressor rotation. The rotating blades arrest the airflow and pass it to a set of stationary stator vanes. The air is again deflected and picked up by another set of rotating blades, and so on through the compressor. The pressure of the air increases each time it passes through a set of rotors and stators because the areas of the rotors and stators get smaller, as shown in *Figure 7-6*.

One development in the axial-flow engine is the split spool compressor. This compressor (*Figure 7-7*) uses two rotors of nine and seven stages, respectively. An assigned wheel drives each rotor of the

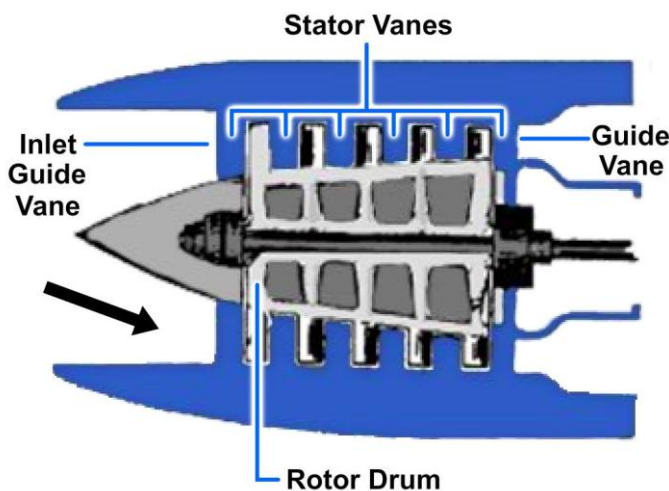


**Compressor Stator Vanes**

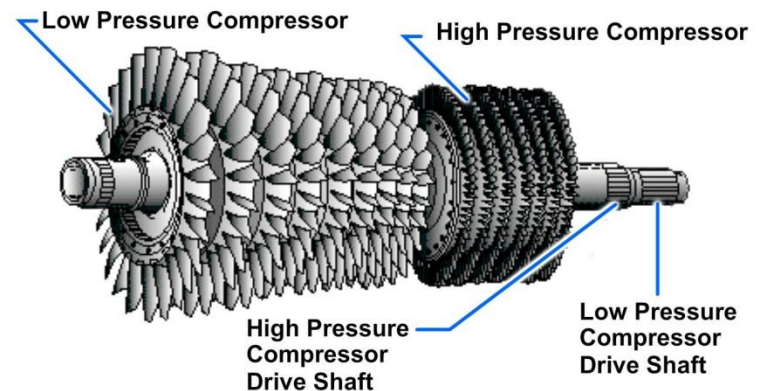


**Compressor Rotor Vanes**

**Figure 7-5 — Stator and rotor components of an axial-flow compressor.**



**Figure 7-6 — Five-stage compressor.**



**Figure 7-7 — Dual rotor turbine for split spool compressor.**

axial three-stage turbine assembly. This configuration makes possible high compressor pressure ratios, which are necessary for efficient high-altitude operations.

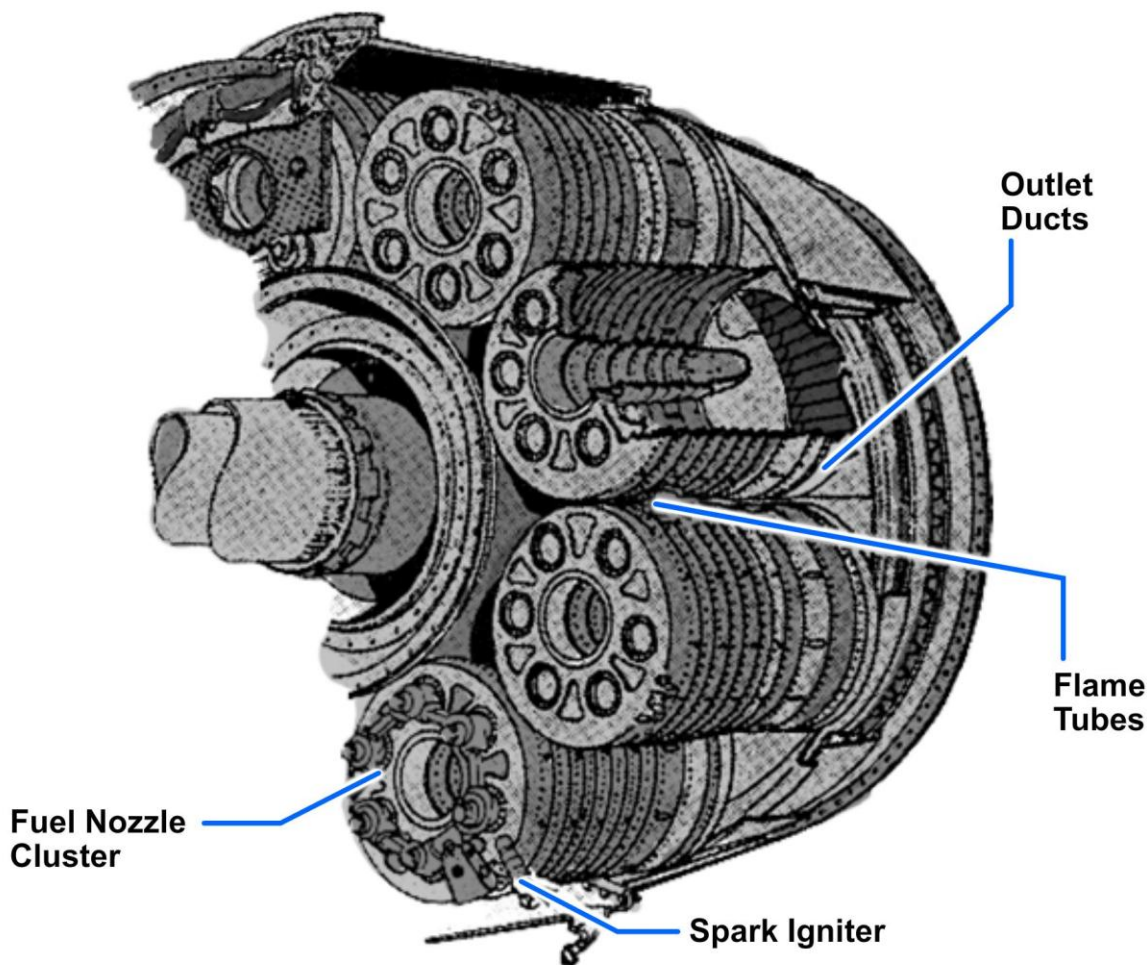
Another development was necessary to eliminate compressor stall in turbojet engines. The axial compressor, especially with fixed blading, was subject to stalling. Compressor stall was normally caused by a breakdown of the airflow through a few stages of the compressor. Compressor stall could progress until the complete unit stalled. There are two methods to eliminate compressor stall: the compressor bleed-air system and the variable vane system. The compressor bleed-air system bleeds off approximately 10 percent of the front compressor discharge air. It reduces the amount of air available to the rear compressor. This design provides a surge-free operation throughout the critical speeds of the engine. The variable vane system changes the position of the inlet guide vanes and the stator vanes to avoid compressor stall. This action maintains the velocity of the air (and the angle at which it strikes the blades) within acceptable limits for low airflow conditions. It also permits high airflow with a minimum of restriction.

## **Combustion Chamber**

The efficiency and performance of a turbine power unit depend on the type of combustion system used. The basic requirements for a satisfactory system are a high rate of burning, minimum pressure drop, small bulk, and light weight. The system must be consistent in operation over a wide range of loads and altitudes, with no tendency to flood with fuel or suffer *combustion blowout*. Combustion blowout is a flame failure, and it is primarily a problem in high-altitude operation. Starting must be easy and positive, both on the ground and in the air. Combustion must be complete to avoid formation of carbon deposits.

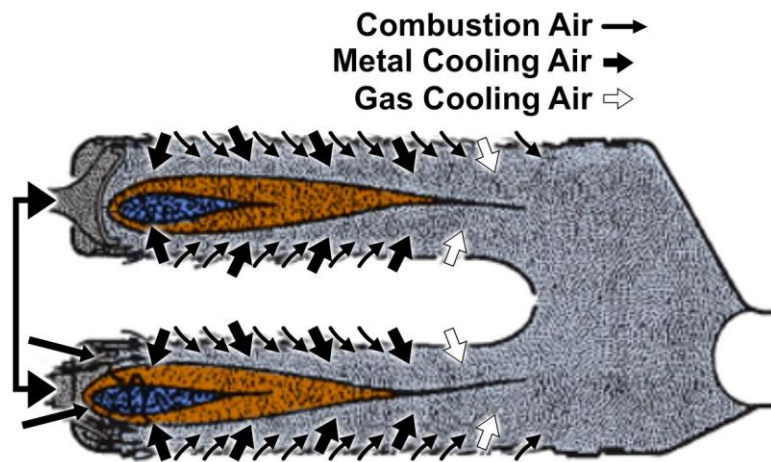
Fuel enters the front of the burner as an atomized spray or in a prevaporized form. Air flows in around the fuel nozzle and through the first row of combustion air holes in the liner. Air near the burner nozzle stays close to the front liner wall for cooling and cleaning purposes. Air entering through opposing liner holes mixes rapidly with the fuel to form a combustible mixture. Air entering the forward section of the liner recirculates and moves upstream against the fuel spray. During combustion, this action permits rapid mixing and prevents flame blowout by forming a low-velocity stabilization zone. This zone acts as a continuous pilot for the rest of the burner. Air entering the downstream part of the liner provides the correct mixture for combustion. This air also creates the intense turbulence necessary for mixing the fuel and air and for transferring energy from the burned to the unburned gases.

Since an engine usually has two igniter plugs, cross ignition tubes are necessary in the can and can-annular types of burners. These tubes allow burning to start in the other cans or inner liners. Axial-flow engines use either an annular or the can-annular (*Figure 7-8*) type of combustion chamber. The igniter plug is usually located in the upstream reverse flow region of the burner. After ignition, the flame quickly spreads to the primary (combustion) zone. This zone contains the correct proportion of air to completely burn the fuel. If all the air flowing through the engine were mixed with the fuel at this point, the mixture would be outside the combustion limits for the fuel normally used. Therefore, only about one-third to one-half of the air is allowed to enter the combustion zone of the burner. About 25 percent of the air actually takes part in the combustion process.



**Figure 7-8 — Can-annular combustion chamber components.**

Gases that result from the combustion process have temperatures of approximately 3,500 °F (1,900 °C). Before entering the turbine, these gases must be cooled to about half this value. The design of the turbine and the materials used in its makeup determine the temperature to which the gases must be cooled. Secondary air, which enters through a set of relatively large holes located toward the rear of the liner, dilutes and cools the hot gases. The liner must also be protected from the high temperatures of combustion. This protection is usually provided by cool air introduced at several different places along the liner. The cool air forms an insulating blanket between the hot gases and the metal walls, as shown in *Figure 7-9*.



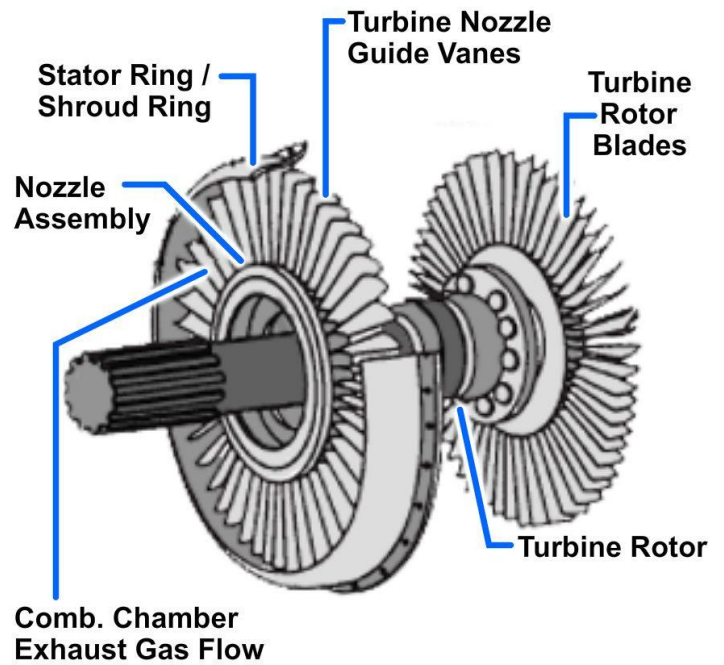
**Figure 7-9 — Airflow through a can-annular chamber.**

### **Turbine**

The turbine assembly drives the compressor and accessories by extracting some of the energy and pressure from the combustion gases. In a typical jet engine, about 75 percent of the power produced internally is used to drive the compressor. The remaining 25 percent produces the necessary thrust.

The turbine consists of a nozzle assembly and a rotating blade assembly. The hot gases from the combustion chamber flow through the turbine nozzle assembly and are directed against the rotating turbine disk blades. The rotating blade assembly (turbine rotor) is made up of a steel shaft and disk. High-temperature alloy blades are locked into grooves cut in the periphery of the disk. The entire turbine rotor is statically and dynamically balanced. In some units, the turbine compressor rotors are mounted on the same shaft. In other units, they are mounted on separate shafts that are connected during assembly.

The nozzle assembly consists of the nozzle guide vanes and the stator ring/shroud ring, as shown in *Figure 7-10*. The guide vanes are made up of high-temperature alloy. They are fitted into or welded to the stator ring/shroud.

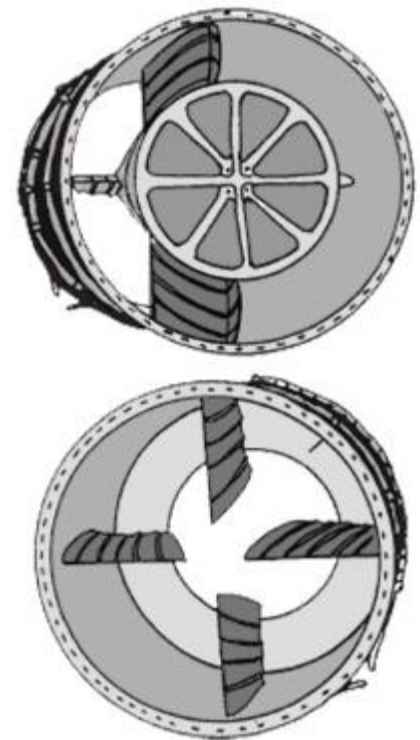


**Figure 7-10 —Turbine rotor and nozzle.**

### Exhaust Cone Assembly

The exhaust cone (*Figure 7-11*), which is attached to the rear of the turbine assembly, is a tapered, cylinder-shaped outlet for the gases. The cone eliminates turbulence in the emerging jet, thereby giving maximum velocity.

The inner cone is usually attached to the outer cone by streamlined vanes called brace assemblies. The exhaust cone itself is usually made of stainless steel sheets, reinforced at each end with stainless steel flanges. As much heat energy as possible is kept within the exhaust cone. A covering of layers of aluminum foil or other material acts as insulation for the cone.



**Figure 7-11 — Typical exhaust cone assembly.**

### Turboprop Engines

There are numerous models of the turboprop engine. The P-3, C-2, and E-2 aircraft are examples of aircraft that use turboprop engines.

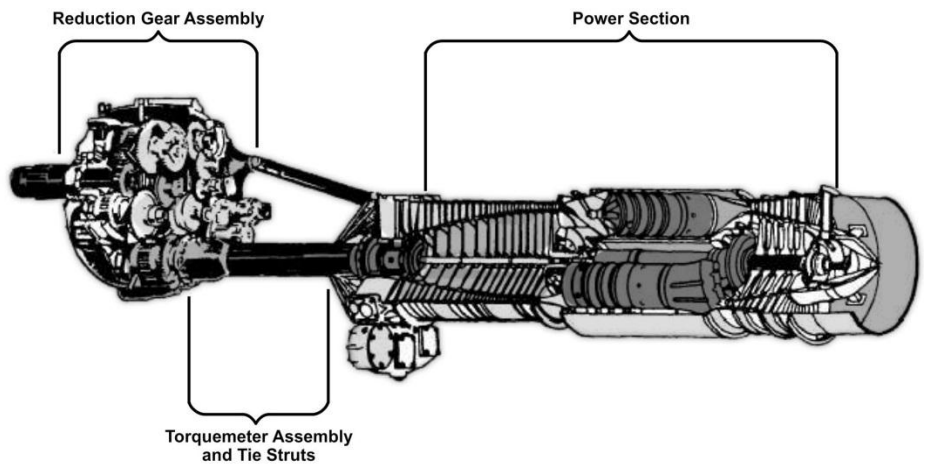
The turboprop engine was developed to provide the power requirements for aircraft of greater size, carrying capacity, range, and speed. The turboprop engine is capable of developing 2 1/2 horsepower per pound of weight.

The turboprop converts most of its gas-energy into mechanical power to drive the compressor, accessories, and a propeller. The additional turbine stages needed to drive the extra load of a propeller create the low-pressure, low-velocity gas stream. A small amount of jet thrust is obtained from this gas stream.

The turboprop engine (*Figure 7-12*) consists of three major assemblies: the power section, the torquemeter assembly, and the reduction gear assembly. The propeller assembly mounts on the reduction gear assembly to provide aircraft thrust.

### Power Section

The power section consists of an axial-flow compressor, a combustion chamber, a multi-stage turbine, and an exhaust section. The last two stages of the turbine are used to drive the propeller using the torquemeter assembly and the reduction gear assembly.



**Figure 7-12 — T56 turboprop engine.**

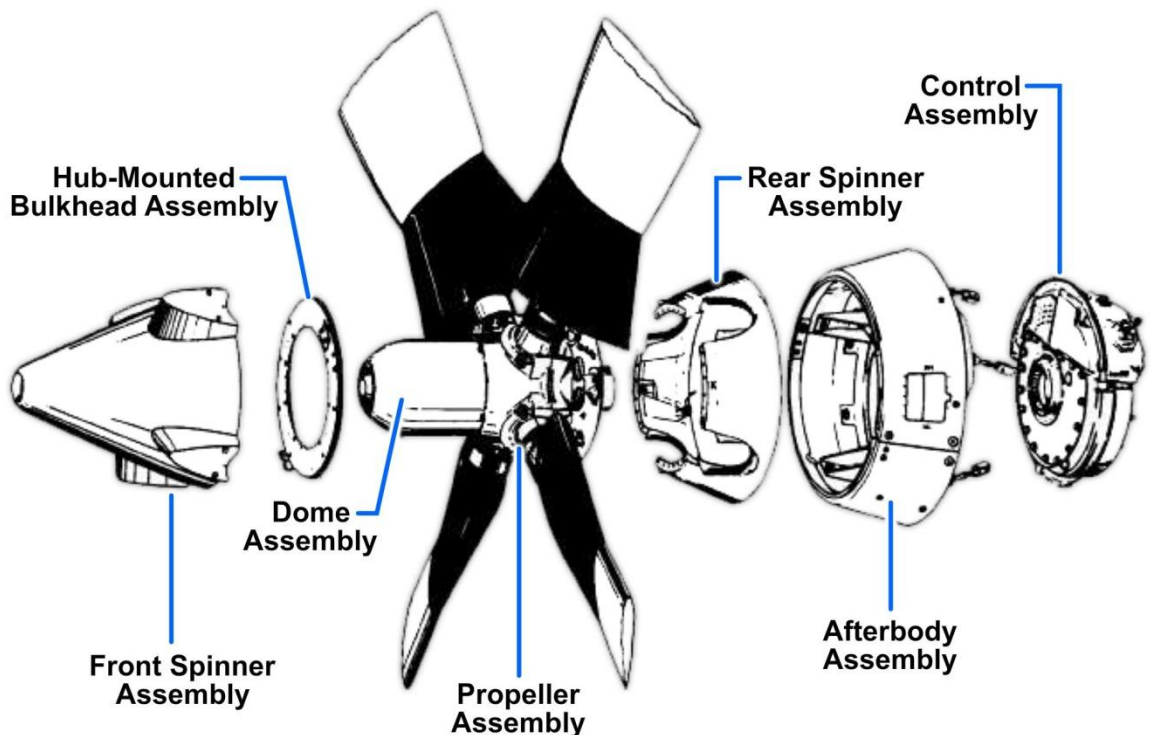
### Torquemeter Assembly

The torquemeter assembly electronically measures the torsional deflection (twist). Torsional deflection occurs in the power transmitting shaft that connects the power section to the reduction gear assembly. This torsional deflection is recorded as horsepower.

### Reduction Gear Assembly

The reduction gear assembly reduces the engine rpm within the range of efficient propeller rpm. The ratio on some installations is as high as 12 or 13 to 1. This large reduction ratio is necessary because the gas turbine must operate at a very high rpm to produce power efficiently.

The turboprop engine operates at a constant rpm. The propeller blade angle changes for an increase or decrease in power while the engine rpm remains the same. The typical propeller assembly for a turboprop engine (*Figure 7-13*) consists of a front and rear spinner assembly, a hub-mounted bulkhead assembly, the dome assembly, four



**Figure 7-13 — Propeller assembly and associated parts.**



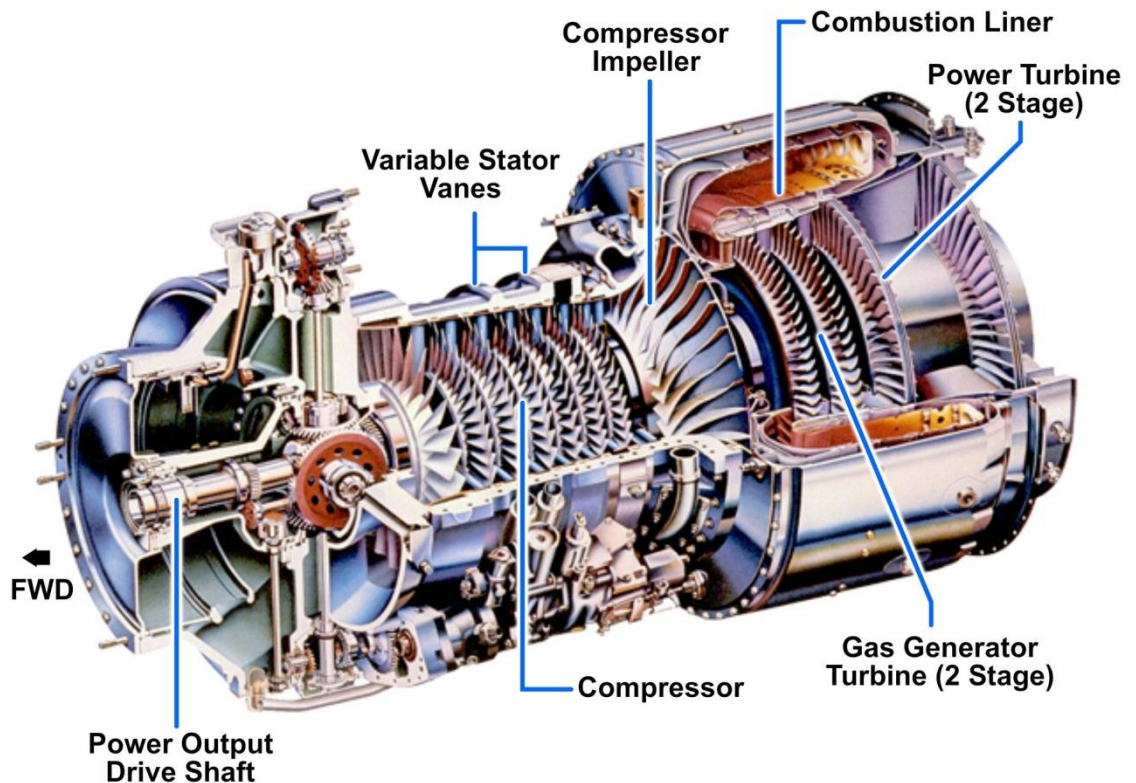
blades, an afterbody fairing assembly, and a propeller control assembly. The propeller assembly converts the power developed by the engine into thrust as efficiently as possible under all operating conditions.

## Turboshaft Engines

There are many different models of this type of engine. The H-60 and H-53 helicopters are examples of aircraft that use this engine. Turboshaft engines have a high power-to-weight ratio and are widely used in helicopters. *Figure 7-14* shows a typical turboshaft engine.

The turboshaft engine is an axial-flow engine that incorporates the free turbine principle. It is composed of a compressor, combustor, gas generator turbine, and power turbine. The engine is equipped with a control system that modulates fuel flow to maintain constant power turbine output speed for a given speed selector setting in the governed range. This system maintains the selected speed by automatically changing the fuel flow to increase or decrease gas generator speed. The pilot determines the speed by positioning the power lever. The control system provides automatic protection against compressor stall, turbine overtemperature, overspeed of both turbine assemblies, and combustion flameout.

An emergency throttle system is provided for use in case of fuel control failure. A starter, mounted at the nose of the engine, drives the gas generator rotor and engine accessories for engine starting. The engine is installed with its nose facing forward and supported by engine mounts bolted to the aircraft fuselage. Air is supplied to the engine through the inlet air duct, located inside the right-hand side door of the center nacelle. An alternate air door is attached to the duct by a hinge. Air is supplied through the alternate air door when an insufficient amount of air comes into the engine through the main air duct. The engine is installed so that, with the nacelle removed, all accessories and components can be easily reached and maintained.



**Figure 7-14 — typical turboshaft engine**

## **Gas Turbine Engine Component Controls, Systems, and Sections**

In addition to the five major components discussed as part of the turbojet engine, there are numerous controls, systems, and sections that are common to all four types of gas turbine engines. Among the more important of these are the fuel control, lubrication system, ignition system, and accessory section.

### **Fuel Control**

Depending upon the type of engine and the performance expected of it, fuel controls may vary in complexity. They may range from simple valves to automatic computing controls containing hundreds of intricate, highly machined parts.

The pilot of a gas turbine-powered aircraft does not directly control the engine. The pilot's relation to the power plant corresponds to that of the bridge officer on a ship. The bridge officer obtains engine response by relaying orders to an engineer below deck, who, in turn, actually moves the throttle of the engine.

Modern fuel controls are divided into two basic groups, hydromechanical and electronic. The controls sense some or all of the following engine operating variables:

1. Pilot's demands (throttle position)
2. Compressor inlet temperature
3. Compressor discharge pressure
4. Burner pressure
5. Compressor inlet pressure
6. Engine rpm
7. Turbine temperature

The more sophisticated fuel controls sense even more operating variables.

The fuel control is the heart of the gas turbine engine fuel system. This complex device schedules fuel flow to the engine combustion chamber. It automatically provides fuel flow as dictated by the operating conditions of the engine (temperature, pressures, altitude, throttle position, etc.).

The fuel control combines the inputs of throttle position, compressor discharge pressure, compressor inlet temperature, and engine speed to produce the fuel flow to operate the engine. The fuel control governs the engine speed by controlling fuel flow. Fuel flow variations are limited to ensure fast stall-free acceleration and deceleration. During throttle bursts, the fuel control also postpones the initiation of the afterburner operation (if installed) to achieve the fastest possible acceleration.

### **Lubrication System**

The oil lubrication systems of modern gas turbine engines vary in design and plumbing. However, most systems have units that perform similar functions. In a majority of cases, a pressure pump or system furnishes oil to lubricate and cool several parts of the engine. A scavenging system returns the oil to the tank for reuse. Overheating is a problem in gas turbine engines. Overheating is more severe after the engine stops than while it is running. Oil flow, which normally cools the bearings, stops. The heat stored in the turbine wheel now raises the temperature of the bearings much higher than when the engine was running. The oil moves heat away from these bearings to prevent overheating. Most systems include a heat exchanger to cool the oil. Many systems have pressurized sumps and a pressurized oil tank. This equipment ensures a constant head pressure to the pressure lubrication pump to prevent pump cavitation at high altitudes.

Oil consumption is relatively low in a gas turbine engine compared to a piston-type engine. Oil consumption in the turbine engine primarily depends upon the efficiency of the seals. However, oil can be lost through internal leakage, and, in some engines, by malfunctioning of the pressurizing or venting system. Oil sealing is very important in a jet engine. Any wetting of the blades or vanes by oil vapor causes accumulation of dust or dirt. Since oil consumption is so low, oil tanks are made small to decrease weight and storage problems.

The main parts of the turbine requiring lubrication and cooling are the main bearings and accessory drive gears. Therefore, lubrication of the gas turbine engine is simple. In some engines the oil operates the servomechanism of fuel controls and controls the position of the variable-area exhaust nozzle vanes.

**⚠ WARNING ⚠**

Because of the high power in these ignition systems, you must be careful to prevent a lethal electrical shock from capacitors. Always avoid contact with leads, connections, and components until the capacitors have been grounded and are fully discharged.

Because each engine bearing gets its oil from a metered or calibrated opening, the lubrication system is known as the calibrated type. With few exceptions, the lubricating system is of the dry sump design. This design carries the bulk of the oil in an airframe or engine-supplied separate tank. In the wet sump system, the oil is carried in the engine itself. All gas turbine engine lubrication systems normally use synthetic oil.

Figure 7-15 shows components that usually make up the dry sump oil system of a gas turbine engine.

### Ignition System

Modern gas turbine engines use high voltage and a spark of high heat intensity. The high-energy, capacitor-discharge type of ignition

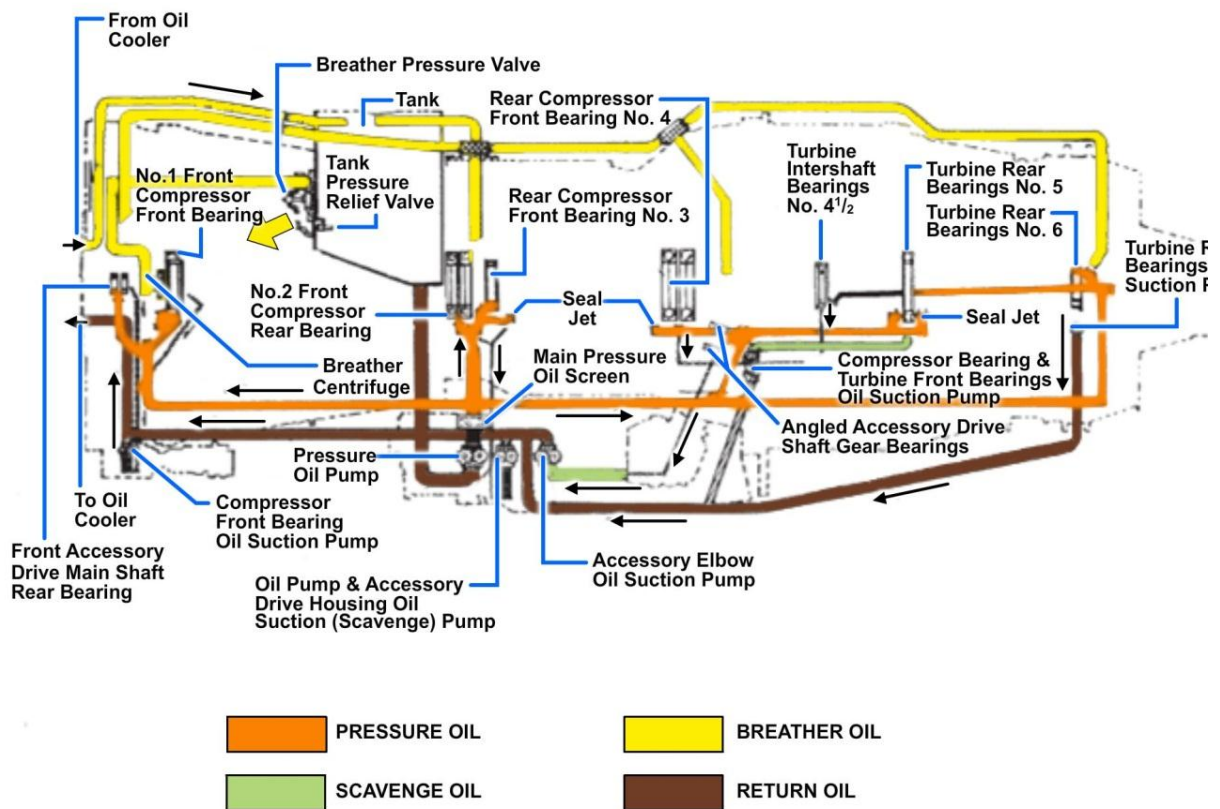


Figure 7-15 — Dry sump oil system.

system provides both high voltage and an exceptionally hot spark. This system assures ignition of the fuel-air mixture at high altitudes.

There are two types of capacitor discharge ignition systems: the high-voltage and the low-voltage systems with dc or ac input. The high-voltage system produces a double spark. The double spark is a high-voltage component. This component ionizes (makes conductive) the gap between the igniter plug electrodes so that the high-energy, low-voltage component may follow. In the low-voltage system, the spark is similar to the high-voltage system, but uses a self-ionizing igniter plug. *Figure 7-16* shows a typical spark igniter.

### Accessory Section

The accessory section of the gas turbine engine is usually mounted beneath the compressor section. This section contains an accessory drive gearbox, a housing (case), and provisions for mounting the engine-driven accessories (constant speed drive transmission, fuel and oil pumps, electrical tachometer generators, etc.). In gas turbine engines with air turbine starters, the starter is mounted on the forward face of the accessory gearbox. The accessory gearbox also includes many of the gas turbine engine's internal lubrication system components.

## THE BRAYTON CYCLE

A cycle is a process that begins with certain conditions and ends with those same conditions. The Brayton cycle is illustrated in *Figure 7-17*. Note that in the gas turbine engine, each cycle is not only performed continuously, but also by a separate component designed for its particular function.

Since all of the events are going on continuously, we can say that all gas turbine engines work on an open cycle. *Figure 7-17* compares the cycles of operation of a piston-type (reciprocating) engine and a gas turbine

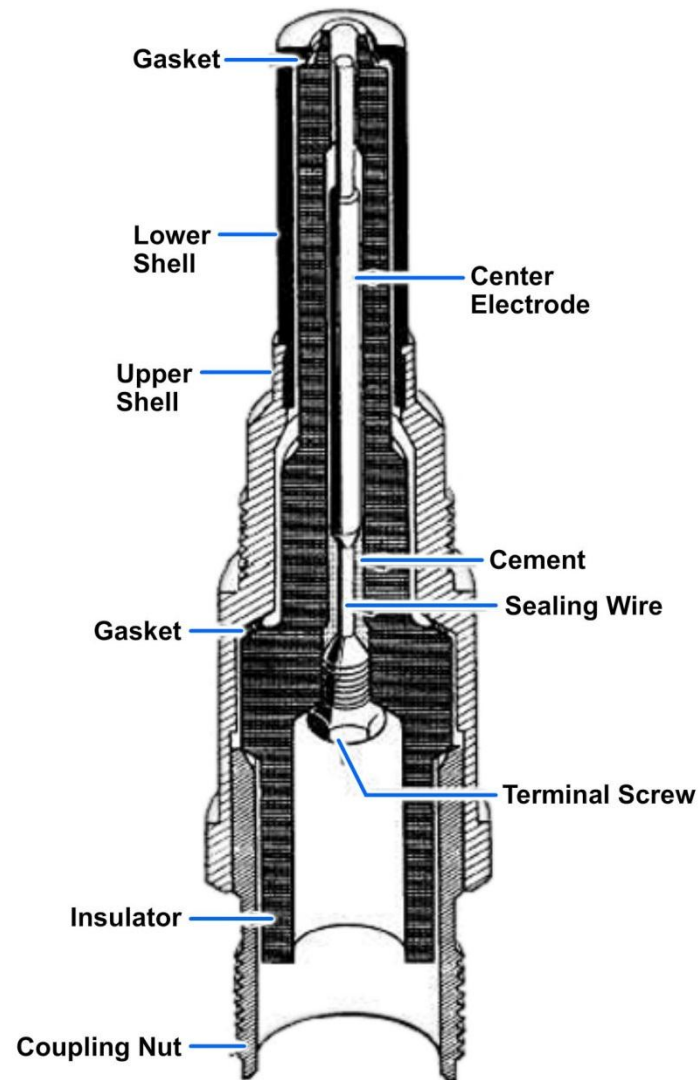


Figure 7-16 — Spark igniter.

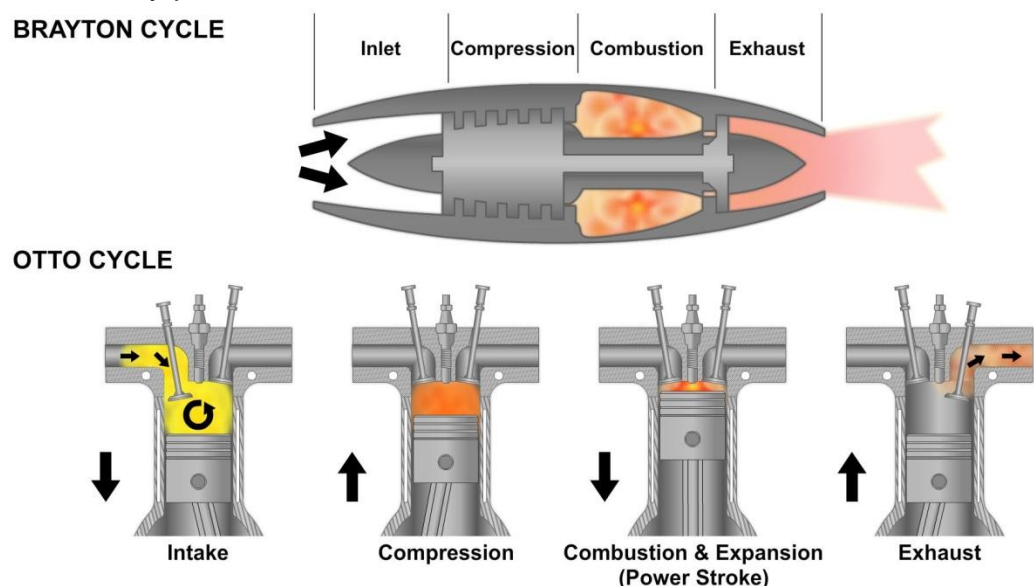


Figure 7-17 — A comparison of turbojet and reciprocating engine cycles.

engine. The piston-type engine produces power by intermittent combustion. The gas turbine engine produces power continuously.

## ENGINE IDENTIFICATION

**Table 7-1 — Aircraft Letter Symbols and Engine Types**

<b>SYMBOL</b>	<b>ENGINE TYPE</b>
J	Aviation gas turbine (turbojet engine)
T	Aviation gas turbine (turboprop and turboshaft engines)

Presently, two engine designation systems identify aircraft power plants. One system is described in Air Force-Navy Aeronautical (ANA) Bulletin No. 306M. The other system, MIL-STD-1812 designation system, includes all newly developed (Air Force, Army, and Navy) gas turbine engines.

These designation systems use standard symbols to represent the types and models of engines now used in military aircraft.

### ANA Bulletin No. 306m Designation System

The following paragraphs describe the ANA Bulletin No. 306M designation system. This system has no provisions for Army designation. T56-A-14 is an example of this system's designation number.

#### Type Symbols

The first part of the designation system is a letter (or letters) that indicates each basic engine type. *Table 7-1* shows the letter symbols that identify engine types.

A number follows the first letter symbol. The armed service using the engine assigns this number. The Navy uses even numbers; the Air Force uses odd numbers:

- The number 30 for the Navy. The Navy has even numbers.
- The number 31 for the Air Force. The Air Force has odd numbers.

The designation of odd or even numbers does not restrict the use of the engine to the sponsoring service. Aircraft engines, regardless of type designation, are used by various services, depending on their applicability for a particular aircraft. In some instances, engines are made interchangeable for a particular airframe.

#### Manufacturer's Symbol

The second part of the designation is a dash and a letter symbol that indicates the engine manufacturer. Some of the manufacturers are listed in *Table 7-2*.

**Table 7-2 — Engine Manufacturers**

<b>MANUFACTURER SYMBOL</b>	<b>MANUFACTURER</b>
AD	Allison Division, General Motors Corp.
BA	Bell Aircraft Company
CA	Continental Aviation and Engineering Corp.
CP	United Aircraft of Canada Ltd.

<b>MANUFACTURER SYMBOL</b>	<b>MANUFACTURER</b>
GA	AiResearch Division, Garrett Corp.
GE	General Electric Company
LA	Lockheed Aircraft Company
LD	Lycoming Division, Avco Corp.
MD	McDonald-Douglas, Aircraft Company
PW	Pratt and Whitney Aircraft Division, United Aircraft Corp.
RR	Rolls Royce, Ltd.
WA	Curtis-Wright Corp.
WE	Westinghouse Electric Company

Special manufacturer's symbols may be assigned when two manufacturers are jointly producing an engine. In these instances, the manufacturer's symbol is one letter from each of the manufacturers' symbols.

### **Model Numbers**

The third part of the designation is a dash and a number indicating the model number.

- Navy numbers begin with 2, and they continue with consecutive even numbers. All even model numbers are assigned to engines approved by the Naval Air Systems Command.
- Air Force numbers begin with 1 and continue with consecutive odd numbers.

Each engine design has only one type and model designation for both the Air Force and Navy. For example, the Navy may wish to use an engine that has Air Force-approved type and model numbers. The Navy may use those numbers without change, provided there are no engine changes. If the Air Force wants to use a Navy-approved type engine, but requires minor engine production changes, the Air Force must use the Navy type designation. It tells which service made the last production change to the engine for a particular aircraft application. The Air Force then assigns its own model designation (which begins with the number 1 and progresses with consecutive odd numbers) to the modified engine, regardless of the Navy model number. This model number is actually a modification number.

### **Special Designations**

The letter X or Y preceding the basic designation signifies a special designation.

The prefix letter X is a basic engine designation signifying the experimental and service test of a particular engine. This prefix letter is removed after tests prove the engine can perform as it should under all operating conditions.

The prefix letter Y indicates a Restricted Service designation. It indicates that the engine will not, or is not expected to, perform satisfactorily under all operating conditions. It is applied to an engine that has a specific function or that has completed a 150-hour qualification test only. Upon satisfactorily completing the qualification testing, the Y designation is dropped. The engine is then approved for installation in a production aircraft.

The following is an example of a complete ANA Bulletin No. 306M engine designation number:

### T56-A-14

- T—Turboprop
- 56—Navy developed
- A—Allison
- 14—Navy model

The ANA Bulletin No. 306M designation system is effective until each engine manufactured before the introduction of MIL-STD-1812 is modified or deleted from service.

### MIL-STD-1812 Designation System

This engine designation system is made up of three-digit numerals and model numbers. It is used on all newly developed gas turbine engines. Existing engines receive a new three-digit model number whenever there are major changes in engine configuration or design. In most instances the old two-digit indicator will be retained. The MIL-STD-1812 engine designation system applies to all the armed services: Air Force, Navy, and the Army.

The complete designation system has three parts: the type indicator, the manufacturer's indicator, and the model indicator. Special designations in this system are the same as those discussed under the ANA Bulletin No. 306M system (X or Y preceding the basic designation).

#### Type Indicator

The first part is the type indicator. It consists of the type letter symbol and the type numeral. Letter type symbols are shown in *Table 7-3*.

**Table 7-3 — Engine Type Indicator**

INDICATOR	ENGINE TYPE
J	Turbojet
T	Turboprop/Turboshaft

#### NOTE

If one service uses other services' designated engines, the designation remains the same unless a model change is required. However, in this case, the model indicator will change to indicate the engine is modified.

The second part is type numerals and type letter symbol are assigned consecutively by each of the services. The numerals begin as follows:

- 100—Air Force
- 400—Navy
- 700—Army

## Model Indicator

The third part is the model indicator. It is a dash and a model number, or a dash and a model number with a suffix letter.

Each configuration of the engine has an assigned model number. Each of the services assigns a block of numbers that are used consecutively.

- 100—Air Force
- 400—Navy
- 700—Army

F401-PW-400 is an example of a MIL-STD-1812 engine designation.

- 401—Second Navy turbofan in designation system
- PW—Pratt and Whitney Aircraft Division, United Aircraft Corporation
- 400—First Navy model of this particular engine

## POWER PLANT SAFETY PRECAUTIONS

Operational readiness of a maximum number of aircraft power plants is necessary if naval aviation is to perform its mission successfully. Keeping aircraft and power plants in top operating condition is the principal function of naval aviation maintenance personnel. This maintenance work must be performed without injury to personnel.

Every person connected with power plant maintenance is responsible for discovering and eliminating unsafe work practices. In the following section, we will discuss a few standard safety precautions. You must follow these precautions to prevent injury to yourself or others working on or near aircraft jet engines.

### Intake Ducts

The air intake ducts of operating jet engines are an extreme hazard to personnel working near the aircraft. Ducts are also a hazard to the engine itself if the area around the front of the aircraft is not kept clear of debris. The air intake duct develops enough suction to pull an individual, or hats, eyeglasses, etc., into the intake. The hazard is obviously greatest during maximum power settings. Protective screens for the ducts are part of the aircraft's ground-handling equipment. These screens must be installed prior to all maintenance turnups.

### Exhaust Area

Jet engine exhausts create many hazards to personnel. The two most serious hazards are the high temperature and the high velocity of the exhaust gases from the tailpipe. High temperatures are present several hundred feet from the tailpipe. The closer you get to the aircraft, the higher the exhaust temperatures and the greater the danger.

When a jet engine is starting, sometimes excess fuel will accumulate in the tailpipe. When this fuel ignites, long flames shoot out of the tailpipe at very high velocity. You will want to stay clear of this danger at all times.

### Engine Noise

Jet engine noise can cause temporary or permanent hearing loss. Hearing loss occurs when your unprotected ear is exposed to high sound intensities for excessive periods of time. The higher the



sound level, the less time it takes to damage your hearing. Without ear protection, persons exposed to sound intensities above 140 decibels (dB) for any length of time may suffer serious hearing damage. You must wear proper ear protection at all times. You should wear double hearing protection when working around turning aircraft.

As an Airman, you must be familiar with all aircraft general safety precautions as well as those peculiar to your squadron. The life you save may be your own.

# End of Chapter 7

## Aircraft Power Plants

### Review Questions

- 7-1. What engine does NOT draw air from the outside to fuel the combustion process?
- A. Gas turbine
  - B. Rocket
  - C. Turboprop
  - D. Turboshaft
- 7-2. How many major components make up a turbojet engine?
- A. 1
  - B. 3
  - C. 5
  - D. 7
- 7-3. What component is an opening in the front of the aircraft that allows outside air to enter the engine?
- A. Inlet duct
  - B. Compressor
  - C. Combustion chamber
  - D. Turbine
- 7-4. What component is attached to the rear of the turbine assembly, and is a tapered, cylinder-shaped outlet for the gases?
- A. Inlet duct
  - B. Compressor
  - C. Combustion chamber
  - D. Exhaust cone
- 7-5. What engine was developed to provide the power requirements for aircraft of greater size, carrying capacity, range, and speed?
- A. Rocket
  - B. Turboprop
  - C. Turborotor
  - D. Turboshaft
- 7-6. How many major sections make up a turboprop engine?
- A. 1
  - B. 2
  - C. 3
  - D. 4

- 7-7. What section of a turboprop engine consists of an axial-flow compressor, a combustion chamber, a multi-stage turbine, and an exhaust?
- A. Power
  - B. Reduction
  - C. Torquemeter
  - D. Tail
- 7-8. What type of engine has a high power-to-weight ratio and is widely used in helicopters?
- A. Rocket
  - B. Turbojet
  - C. Turboprop
  - D. Turboshaft
- 7-9. What component on a gas turbine engine is the heart of the gas fuel system?
- A. Accessory section
  - B. Ignition system
  - C. Fuel control
  - D. Exhaust cone
- 7-10. How many different types of ignition systems are used on gas turbine engines?
- A. 1
  - B. 2
  - C. 3
  - D. 4
- 7-11. What section on a gas turbine engine is usually mounted beneath the compressor?
- A. Fuel control
  - B. Accessory
  - C. Ignition
  - D. Lubrication
- 7-12. What cycle is used to describe the gas turbine engine's cycle?
- A. Amber
  - B. Braxton
  - C. Brayton
  - D. Camber

- 7-13. What symbol is used for an aviation gas turbine engine type?
- A. A
  - B. J
  - C. K
  - D. T
- 7-14. How many designation systems are used to identify aircraft power plants?
- A. 2
  - B. 4
  - C. 6
  - D. 8
- 7-15. What is the engine manufacturer symbol for United Aircraft of Canada Ltd.?
- A. AD
  - B. BA
  - C. CA
  - D. CP
- 7-16. What is the engine manufacturer symbol for AiResearch Division, Garrett Corp.?
- A. BA
  - B. GA
  - C. LD
  - D. MD
- 7-17. Without ear protection, persons exposed to sound intensities above what dB may suffer hearing damage?
- A. 110
  - B. 120
  - C. 130
  - D. 140
- 7-18. What area on an aircraft produces the two most serious hazards, the high temperature and the high velocity of the tailpipe?
- A. Exhaust
  - B. Intake
  - C. Landing gear
  - D. Main rotor

7-19. What area on an aircraft develops enough suction to pull in an individual?

- A. Exhaust
- B. Intake
- C. Landing gear
- D. Main rotor

7-20. Keeping aircraft and power plants in top operating condition is the principal function of what type of personnel?

- A. Admin
- B. Maintenance
- C. Medical
- D. Security

# RATE TRAINING MANUAL – USER UPDATE

CNATT makes every effort to keep their manuals up-to-date and free of technical errors. We appreciate your help in this process. If you have an idea for improving this manual, or if you find an error, a typographical mistake, or an inaccuracy in CNATT manuals, please write or e-mail us, using this form or a photocopy. Be sure to include the exact chapter number, topic, detailed description, and correction, if applicable. Your input will be brought to the attention of the Technical Review Committee. Thank you for your assistance.

Write: CNATT Rate Training Manager  
230 Chevalier Field Avenue  
Pensacola, FL 32508  
COMM: (850) 452-9700 Ext. 3190 for the N73 Director  
DSN: 922-9700 Ext. 3190 for the N73 Director

E-mail: Refer to any of the Aviation Rating pages under CNATT on the NKO Web page for current contact information.

Rate_____ Course Name_____
Revision Date_____ Chapter Number_____ Page Number(s)_____
Description
_____
_____
_____
(Optional) Correction
_____
_____
_____
(Optional) Your Name and Address
_____
_____
_____