

Road Construction Materials

Basic Knowledge and Test Procedures



J. Kisunge

Road Construction Materials

Basic Knowledge and Test Procedures

J. Kisunge

January 2012

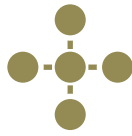

'Dedicated to my wife Specioza and my daughter Grace'

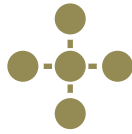

Foreword



Road construction

This Guide is a refined edition of the **Road Construction Materials** (*Fundamental Tests, Formulae and Terminology*) issued in March 2003 as a draft for sharpening the knowledge of laboratory personnel (young engineers and technicians) who are responsible for the quality control of the roadbuilding materials.

Due to economic growth and rapid development in Tanzania, the government has been boosting the road budget yearly, resulting in many road projects in the country at a time; hence, expanding job market for the local highway engineers. However, competency in highway technology (especially materials) has been impeding most engineers from the market.

As the roads construction boosted up in the country in 90's, most of the local highway engineers were still at colleges and universities for their studies, while the graduate engineers had no experience in highway engineering for lack of training sites. Therefore, the past few years of road constructions have been a transition period for most graduate engineers to acquire field experience.

However, Tanzanian is a large territory with variable geology and topography, therefore, the field of practice for a highway engineer is so broad to cover, otherwise the experience mounted up by most engineers might be of similar nature (alike design standards, identical specifications, similar materials and environments), which does not build professionalism.

A highway engineer who has gained most of his/her field experience in one part of the country loses self-confidence when he/she goes to another part of the country with different types of materials and environment. For instance, a materials engineer who is used to deal with the natural gravels stares when he/she faces stabilization process. This happens also to an engineer who has spent most of his/her time on the surface treatments when gets involved in asphalt technology.

Despite the modern technological materials, the local highway and material engineers need enough time to master the country topography and geology before declaring their experiences.



Geological map of Tanzania

Some types of local Gravels



For instance, they are supposed to understand the behavior and performance of lateritic gravels and granite rocks found in the Lake zone, quartzitic gravels and gneiss rocks in the Central zone, coral gravels and limestone in the Coast regions, scoria and basalt found in the volcanic regions (e.g. Kilimanjaro, Arusha and Mbeya) and so on, instead of jumping into a complex design or applications of the imported materials that might be costly or environmentally non-compliant.

The material engineers should bear in mind that, the right judgment on materials quality comes through broad understanding of the materials behavior, rather than just comparing test results with the specification figures. That is in view of the fact that, an impractical material engineer may let marginal materials pass just by opening his/her eyes wider on the test value than the material itself. On the other hand, he/she may not be able to consider potential modifications for the marginal materials before use or rejection, in order to facilitate the progress of the project.

In general, experience is not gained through specific syllabus, but through participating in several self-contained projects, maintaining self-discipline in doing physical works, having attitude of learning from nonprofessionals and professionals; and building self-confidence. Bear in mind that, *qualification* is just a field of study, but *professionalism* comes through extensive experience. Nevertheless, experience is not the number of years spent in the field of profession, but is about what someone has gained in his/her field of profession.

This Guide is intended therefore, to assist the material engineers and other quality control personnel (e.g. laboratory technicians, work supervisors, etc.) with concise knowledge about highway materials and their applications. It is giving important tips (definitions, main points and illustrations) and the outlined procedures for conducting basic tests at project level. It is therefore, a backing tool for the materials practitioners.

J. Kisunge

Table of Contents

Chapter	Page
1. Introduction.....	1
2. Quality Control.....	2
3. Aggregate Materials.....	5
3.1. Grading.....	6
3.2. Shape Test (FI and EI).....	9
3.3. Aggregate Crushing Value (ACV).....	11
3.4. Ten percent Fines Value (TFV).....	12
3.5. Aggregate Impact Value (AIV).....	13
3.6. Los Angeles Abrasion (LAA).....	14
3.7. Sulphate Soundness (SS).....	15
3.8. Organic Impurities.....	17
3.9. Clay lumps and Friable particles.....	18
3.10. Materials finer than 0.075mm.....	19
3.11. Lightweight Pieces.....	20
3.12. Acid-soluble Materials.....	21
3.13. Specific Gravity (SG).....	22
3.14. Sand Equivalent (SE).....	24
4. Concrete Materials.....	25
4.1. Cement.....	25
4.2. Aggregate.....	28
4.3. Water.....	30
4.4. Reinforcements.....	31
4.5. Admixtures.....	34
4.6. Concrete Mix.....	35
4.7. Workability and Strength.....	39
4.8. Quality and Durability.....	43

5. Soil Materials.....	45
5.1. Grading.....	46
5.2. Atterberg limits.....	49
5.3. Proctor.....	53
5.4. CBR.....	56
5.5. Field density.....	63
5.6. DCP Test.....	66
5.7. Specific gravity.....	68
6. Asphalt Materials.....	69
6.1. Bitumen.....	69
6.2. Mix Design.....	71
6.3. Immersion Index.....	79
7. Surface Treatment.....	80
7.1. Binder.....	80
7.2. Chipping.....	80
7.3. Application rates.....	81
7.4. Site application.....	84
References.....	85
Appendices.....	86
Appendix 1: Simple but Confusing terms.....	86
Appendix 2: Road Terminology.....	87
Appendix 3: Pictorial description of Road terms.....	88
Appendix 4: Sieve Standards.....	89

Chapter 1

Introduction



Traffic Over-loading



Pavement Rutting



Pavement Cracks

Although majority of the road failures are normally reported as outcome of traffic over-loading and environmental influences, distress investigations reveal that most of the road failures in Tanzania develop prematurely due to the use of substandard materials and poor construction techniques rather than over-loading and environmental influences. This brings views that, for a road project to achieve quality product that would fulfil the functional and structural requirement with high degree of confidence it must have appropriate and effective quality system, which screens out substandard materials and put a stop to poor construction techniques.

In order to be appropriate and effective, quality system should comprise the knowledgeable staff, proper testing plan and equipment. It should also focus on the materials quality before being used to a permanent work and monitor closely the processing and finishing techniques. Durability of pavement is not judged instantly by the appearance of final product, but is guaranteed by proper design, good quality of materials and proper construction techniques. Specifications alone are not enough to produce a durable road if quality of the applicable materials is not accurately revealed and cared for.

Quality control requires not only a good knowledge of materials characteristics, but also being confident in handling and testing the materials, correct interpretation of the test results, timely delivery of the test results and familiarity with the construction techniques.

However there are many written books and standard specifications, which describe the characteristics of road construction materials, most of them are based on the European and American practices and environments. Such books do not focus much on the Tanzanian materials, which may fail to meet the overseas specifications but perform satisfactorily in the local environments.

Therefore, it is the responsibility of local engineers to write down their experiences on the performance of local materials and set the best practices of treating such materials.

Chapter 2

Quality Control



Sample handling

Quality Control is a common terminology in most construction sites and is frequently used by the laboratory personnel; however, its meaning might not be clearly known by everyone. The term contains two words, *quality* (which means standards) and *control* (which means regulate or monitor). Therefore, *Quality Control* may be defined as the organized operations (inspections, sampling and testing) necessary for regulating or monitoring the work standards.

The main objectives of quality control in a road project are;

- o To screen-out and prevent the use of substandard materials in the project by conducting preliminary and routine testing.
- o To inspect the production process and enable quick corrections whenever production deviates from the project standards.
- o To weigh up and grade the final product for acceptance.

Quality control takes account of materials properties (beneficial and detrimental behaviour), application methods (workmanship) and the value of final product. However, since materials testing and inspections are normally carried out by laboratory personnel with different levels of knowledge and experience, it is extremely important to have a standard system that controls and unifies the laboratory operations in order to ensure reliability of the test results.

Principally, the main concern in quality control process is not just the test result recorded during testing, but truth of the result and its effect on the final product. Therefore, quality control plan should not be limited to sampling procedure and testing methods only, but should also take personal knowledge into account, as well as the attitude and tactics of conducting field inspections and using the laboratory equipment to avoid erroneous results.

On the other hand, the quality control manager (or engineer) should prepare a regular calibration schedule for the laboratory equipment (to retain their precision); and ensure the personnel put into practice the laboratory principles to avoid injuries and damages to equipment.



Materials laboratory

Protective Gears



Some basic principles to be obeyed when working in materials laboratory are:

1. Think before you do (make right judgement before you take action).
2. Use protective gears (gloves, aprons, etc.) when handling hot materials or chemicals.
3. Deal with hot materials or dangerous chemicals at a designated place, avoid hazardous environment.
4. Do not litter waste materials or spill liquids on the floor (may cause accident).
5. Do not handle materials or equipment in a way that may cause accident or injury.
6. Ask for assistance in case of handling heavy objects.
7. Do not switch on or work with electrical apparatus with wet hands.
8. Do not use a device or machine that you do not know how to operate.
9. Follow the instruction manuals provided by the manufactures for operating the machines or other testing devices.
10. Inspect the testing equipment before using it (make sure that it is properly assembled and its parts are perfect).
11. Make sure the testing environment is free from congestion and interference from other operations (e.g. vibrations, vapour, heat, etc.)
12. Obey the nature of each device and use it for its intended use only (do not overload machine or balance; or put plastic devices in oven, etc.)
13. Make sure the testing machine is free and the power put 'off' after testing (do not leave a machine 'on' or any weight on the balance).
14. Put equipments in the right place after testing (do not combine glassware or plastic apparatus with metallic equipment).
15. Be clean and leave the laboratory tidy after testing.

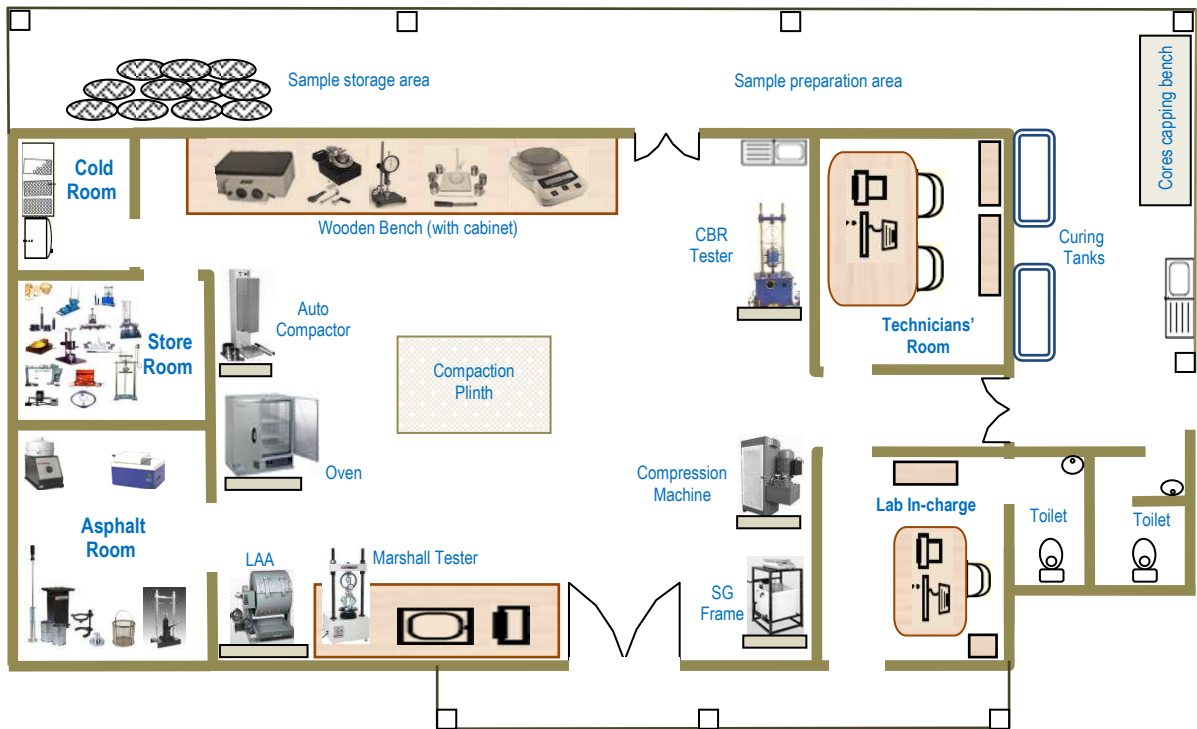
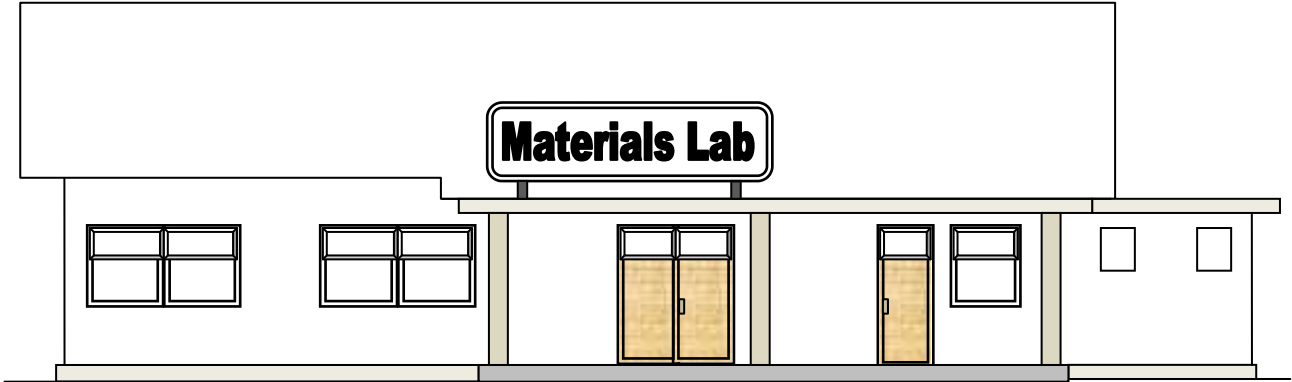

Figure 1: Typical laboratory arrangement

Chapter 3

Aggregate Materials



Crushed Aggregate

Aggregates are broken pieces of stone, obtained by blasting and crushing a parent rock or stone boulders in a designated size; or by screening suitable gravels from natural sources. However, coarse aggregates obtained from natural sources are sometimes polished or weathered due to formation and transportation modes. Therefore, natural sources may be ideal for fine aggregate (natural sand) than coarse aggregates.

However Tanzania is a large territory with variable geology, aggregates produced in the country are mainly from *granite* and *gneiss* rocks in the upcountry regions, *basalt* in the volcanic regions and *limestone* in the coast regions. Granite, gneiss and basalt are hard and strong enough to resist heavy loads, while limestone is porous and soft; hence, so weak to sustain heavy loads.

Aggregate is used in a concrete mix as an extender (bulking material) to reduce cost and control shrinkage, in pavement layers as base course material (CRS and CRR), as chipping for surface dressing and it takes up about 95% of asphalt mixes. Additionally, graded aggregate is used to improve the strength (CBR) of weak soils (known as ‘mechanical stabilization’).

However, before being used in any mix, aggregate should be clean and strong enough to resist forces (e.g. crushing, abrasion, impact, etc.) and durable under exposure conditions (e.g. heat, chemical attack, etc.). Soft aggregate (e.g., limestone, sandstone, etc.) should not be used where high strength is required (unless it is the only option and design modification is made to accommodate such weak aggregate).



River Sand

Aggregate particles should have angular shape to form tight interlock and rough enough to produce frictional resistance in a mix. Flaky or elongated aggregates should be avoided, as they break and do not pack tightly during compaction. For aggregate to produce adequate density and stability during compaction, it should contain a wide range of particle sizes (from fine to coarse) that can fill the mix matrix.

Some of the common tests used to examine the quality of aggregate are; Grading, Shape test (FI and EI), ACV, TFV, AIV, LAA, SG, Sulphate Soundness, Organic test, Clay lumps, etc.

3.1. Grading

Grading test is also known as *sieve analysis* or *particle size distribution*. The test reveals the proportions of different particle sizes in a granular material (e.g. aggregate, soil, etc.) by passing a sample on a range of sieve sizes. A dry sample is passed on the sieves either without washing (known as *dry sieving*) or after soaking and washing the sample over 0.075mm sieve to diffuse the sticking particles prior to sieving (known as *wet sieving*). Dry sieving is used for cohesionless (non-plastic) materials like sand and aggregate; while wet sieving is preferred for cohesive materials like soil and fillers.

Some terms encountered in the grading test are;

Sieve:- wire-cloth or square-mesh with apertures (openings) of definite dimensions nested on a brass or stainless steel frame.

Quartering:- the process of obtaining a small representative quantity of sample by dividing a large quantity of material into quarters (four nearly equal parts) and combining the two opposite parts (as shown below), then dividing the combined parts several rounds until a small representative quantity is obtained.

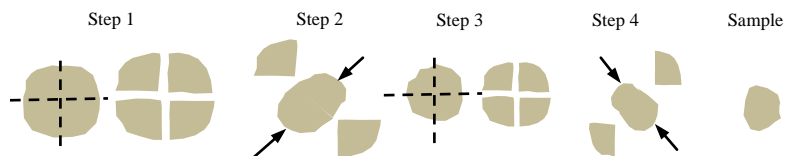

Riffing:- the process of obtaining a small representative quantity of sample by dividing a large quantity of material using a *riffle box* or *sample splitter* (containing alternating slots), which divide the material into two equal parts. Then, one of the obtained two parts is poured again into the slots until the desired quantity is obtained.

Test procedure:

a) Dry Sieving:

- 1) Obtain a test sample by quartering or riffing the material.
- 2) Dry the sample in oven (at 105 – 110 °C) and allow it to cool.
- 3) Record the weight of test sample after cooling (*m1*).
- 4) Arrange the specified sieves with a receiver at the bottom side.
- 5) Pour sample in the topmost sieve and cover it, then shake the sieves until no more material passes through each sieve.
- 6) Weigh (either individually or cumulatively) the material retained on each sieve (*m2*).



Sample Splitter

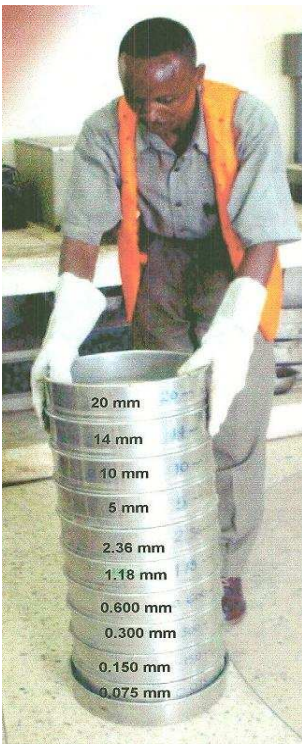

Grading Sieves



Retained particles

b) Wet Sieving:

- 1) Obtain a test sample by quartering or riffing the material.
- 2) Dry the sample in oven (at 105 -110^o C) and then allow it to cool to a room temperature.
- 3) Determine the weight of the test sample after cooling (*m1*).
- 4) Wash the sample on a 0.075mm sieve (place 1.18mm or 2.36mm sieve on top of the 0.075mm sieve to protect the wire cloth from tearing).
- 5) Dry the washed sample in oven for at least 12 hours.
- 6) Arrange the specified series of sieves with a receiver at the bottom side.
- 7) Pour sample in the topmost sieve and cover it with the lid (if the sample is too large, then pour a little quantity at a time).
- 8) Shake all sieves (by hand or a mechanical shaker) until no more material passes through each sieve.
- 9) Determine the weight (individually or cumulatively) of the material retained on each sieve (*m2*).

Note: Cumulative weights provide the percentage of particles retained on the sieves progressively, while individual weights provide the percentage retained on an individual sieve (does not follow the sieve sequence).

Calculations:

- Cumulative percentage *retained* on each sieve:

$$\% \text{ retained} = \frac{m2 \times 100}{m1}$$

- Cumulative percentage *passing* on each sieve:

$$\% \text{ passing} = 100 - \% \text{ retained}$$

- Fineness modulus (FM):

(Calculated for fine aggregates used for concrete, the applicable sieves are 4.75, 2.36, 1.18, 0.600, 0.300 and 0.150).

$$FM = \frac{\text{Sum of the cumulative \%retained on the sieves}}{100}$$

- Coefficient of uniformity (the ratio of **d₆₀** to **d₁₀**):

$$Cu = \frac{d_{60} \text{ (The sieve size at which 60\% of the material passes)}}{d_{10} \text{ (The sieve size at which 10\% of the material passes)}}$$

Example:

Project	TAIFA AVENUE	Checked By:
Location	STOCKPILE YARD	
Material	FINE AGGREGATE - (5 mm)	Date:
Tested by	J. KISUNGE	Approved By:
Date	January 2003	
Ref:	BS 812: Part 103.1	Date:

Total Weight of Sample (g)		1125.1		Remarks
Sieve (mm)	Wt retained (g)	% Retained	% Passing	
50	0	0.0	100	
37.5	0	0.0	100	
28	0	0.0	100	
20	0	0.0	100	
14	0	0.0	100	
10	0	0.0	100	
5.0	71.4	6.3	93.7	
2.36	130.0	11.6	88.4	
1.18	221.2	19.7	80.3	
0.600	389.0	34.6	65.4	
0.300	631.0	56.1	43.9	
0.150	856.9	76.2	23.8	
0.075	1032.7	91.8	8.2	
Pan				

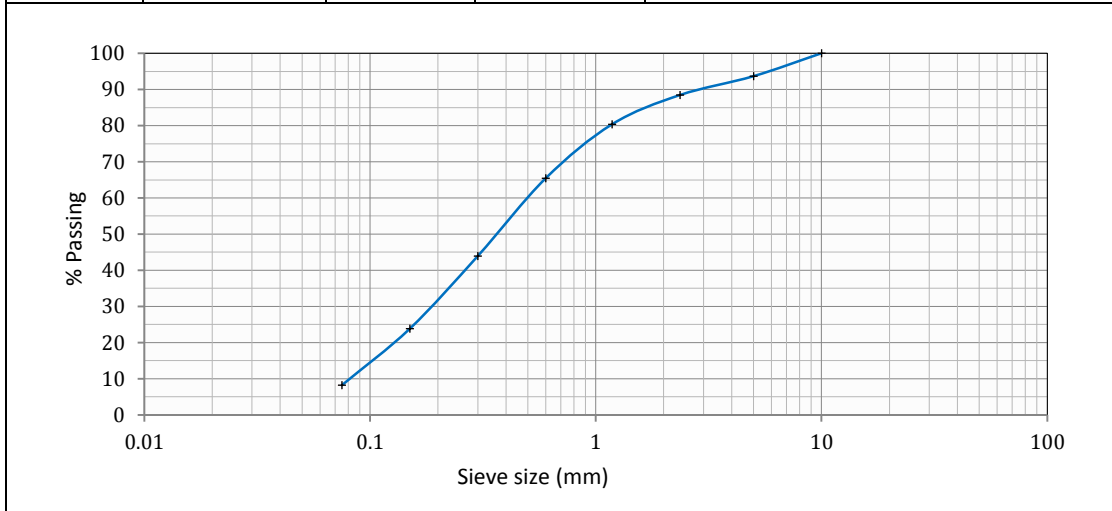

Calculations:

Percentage retained :	$\frac{\text{Wt. retained on the sieve} \times 100}{\text{Total weight of sample}}$	Example (for 5mm sieve)	$\frac{71.4 \times 100}{1125.1} = 6.3 \%$
Percentage passing :	$100 - \% \text{ Retained on the sieve}$	Example (for 5mm sieve)	$100 - 6.3 = 93.7 \%$
Fineness modulus (FM):	$\frac{\text{Sum of cumulative \% retained}}{100}$	Example	$\frac{6.3 + 11.6 + 19.7 + 34.6 + 56.1 + 76.2}{100} = 2.0$
Coefficient of Uniformity (C _u):	$\frac{d_{60} \text{ (sieve size at which 60\% passes)}}{d_{10} \text{ (sieve size at which 10\% passes)}}$	Example	$\frac{(d_{60} = 0.5\text{mm})}{(d_{10} = 0.08\text{mm})} = 6.25$

3.2. Shape test

Shape tests comprise *flakiness index (FI)* and *elongation index (EI)*. The indices obtained in both tests reveal the dimensions of aggregate particles, as some particles are normally cubic while others are flaky or elongated.



Flaky particles

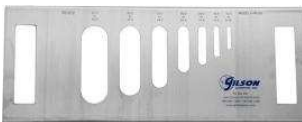

Thickness Gauge

a) Flakiness index (FI)

Flaky particles are the particles whose thicknesses are less than 0.6 of their mean size (e.g. mean size of 14–10mm fraction is 12mm, therefore, thickness of flaky particle is less than $0.6 \times 12 = 7.2\text{mm}$). The test is carried out on the aggregate particles of different sizes from 6.3mm to 63mm using *thickness gauge* (with specific slot sizes).

Test procedure:

- 1) Obtain the test sample by quartering or riffing the aggregate.
- 2) Weigh and record the weight of the obtained sample.
- 3) Sieve the sample on 63, 50, 37.5, 28, 20, 14, 10 and 6.3 mm sieves and discard the sizes larger than 63 mm and smaller than 6.3 mm.
- 4) Determine the weight of particles retained on each sieve and discard the size whose weight is less than 5% of the total sample.
- 5) Pass each fraction through the specified slot on the gauge.
- 6) Determine the weight of particles passing through each slot.

Calculations:

$$FI = \frac{\text{Total weight of particles passing through the slots} \times 100}{\text{Total weight of sample (excluding the discarded size)}}$$

Example:

Aggregate fraction (mm)	Wt. of fraction (g)	Wt. Retained on the gauge (g)	Wt. Passing on the gauge (g)
63 - 50	2131.3	1971.5	159.8
50 - 37.5	2045.6	1840.5	205.1
37.5 - 28	1987.1	1748.6	238.5
28 - 20	1875.6	1688.0	187.6
20 - 14	1563.9	1345.0	218.9
14 - 10	1245.2	1033.5	211.7
10 - 6.3	856.0	624.9	231.1
Total	11704.7		1452.7
$FI = \frac{1452.7 \times 100}{11704.7}$		$= 12.4\%$	



Passing particle through the Gauge

b) Elongation index (EI)

Elongated particles are the particles whose lengths are more than 1.8 of their mean size (i.e. 1.8 x mean size). It is carried out on the coarse particles from 6.3mm to 50mm, using an *elongation gauge* having specific gaps (as shown at the bottom of illustration column).



Elongated Particles

Test procedure:

- 1) Obtain the test sample by quartering or riffing the aggregate.
- 2) Weigh and record the weight of the obtained sample.
- 3) Sieve the sample on 50, 37.5, 28, 20, 14, 10 and 6.3 mm sieves and discard the particles larger than 50 mm and smaller than 6.3 mm.
- 4) Determine the weight of particles retained on each sieve and discard the size whose weight is less than 5% of the total sample.
- 5) Pass each fraction through the specified gap on the elongation gauge.
- 6) Weigh the particles that do not pass through the designated gaps (i.e. elongated particles).

Calculations:

$$EI = \frac{\text{Total weight of the retaining particles} \times 100}{\text{Total weight of sample (excluding the discarded size)}}$$

Example:



Elongation Gauge

Aggregate fraction (mm)	Wt. of fraction (g)	Wt. Retained on the gauge (g)	Wt. Passing on the gauge (g)
50 - 37.5	1988.6	488.9	1499.7
37.5 - 28	1869.7	198.5	1671.2
28 - 20	1754.6	221.9	1532.7
20 - 14	1331.1	111.4	1219.7
14 - 10	1051.6	317.2	734.4
10 - 6.3	961.7	105.1	856.6
Total	8957.3	1443.0	
Elongation Index = $\frac{1443.0 \times 100}{8957.3}$ = 16.1%			

3.3. Aggregate Crushing Value (ACV)

Some aggregate particles resist crushing while some crush during rolling (due to the effect of weathering process or micro-fractures developed by blasting or crushing operations). Crushing of aggregates during construction process affects the grading, density and strength of a mix or layer made with such aggregate.

To measure resistance of aggregate to crushing, the ACV test is carried out on the 14 – 10mm aggregate fraction, by applying a 400 KN force gradually over a period of 10 minutes.

Test procedure:

- 1) Obtain the required fraction by sieving the aggregate on 14mm and 10mm sieves.
- 2) Take the fraction passing 14mm but retaining on 10mm sieve and dry it in oven for about 4 hours before testing.
- 3) Fill the mould with three layers of the dry sample and strike each layer with 25 strokes of the tamping rod.
- 4) Level the surface of the material and insert the crushing plunger into the mould.
- 5) Place the mould (with sample and plunger) on the platen of the concrete compression machine.
- 6) Apply 400 KN force gradually over a period of 10 minutes.
- 7) After 10 minutes; release force, pour the material in a clean tray and determine its total weight (m_1).
- 8) Then, sieve the material thoroughly on 2.36mm sieve.
- 9) Weigh the material retained on 2.36mm sieve (m_2).

Calculations:

- Weight of material passing 2.36mm = $m_1 - m_2$
- $ACV = \frac{(m_1 - m_2) \times 100}{m_1}$

Example:

Sample no.	1	2	3	Average
Total weight of sample (m_1)	2798.7	2811.2	2967.4	20.5
Wt. Retained on 2.36mm (m_2)	2210.9	2249.0	2362.4	
Wt. Passing 2.36mm ($m_1 - m_2$)	587.8	562.2	605.0	
ACV (%)	21.0	20.0	20.4	



Rock fissures



ACV Test Set

3.4. Ten percent Fines Value (TFV)

TFV test also measures the resistance of aggregate to crushing. It is also conducted on the 14 – 10mm fraction as for the ACV test, however, the TFV is preferred for weak aggregates in order to overcome the cushioning effect of excessive fines that might be produced by the ACV test. The test is carried out on a dry or soaked aggregate sample.



TFV Test Set

Test procedure:

- 1) Sieve the aggregate on 14mm and 10mm sieves as for the ACV.
- 2) Fill the ACV mould with three layers of fraction retained on 10mm sieve and strike each layer with 25 strokes of tamping rod.
- 3) Level the material and insert the crushing plunger in the mould.
- 4) Place the mould (with sample and plunger) on the platen of the concrete compression machine.
- 5) Apply a certain force so as to cause penetration of 20mm on the materials surface in 10 minutes and record it (f).
- 6) After 10 minutes, release the force, pour material in a clean tray and determine its weight ($m1$).
- 7) Sieve the whole material on 2.36mm sieve.
- 8) Weigh the material retained on 2.36mm sieve ($m2$).

Calculations:

- Weight of material passing 2.36mm = $m1 - m2$
- % passing 2.36mm sieve (M) = $\frac{(m1 - m2) \times 100}{m1}$
- $TFV = \frac{14f}{M + 4}$

Where;

M = the percentage passing 2.36mm sieve (ranging 7.5% – 12.5%; if not, then prepare and test another sample with adjusted force until the value obtained falls within the mentioned range).

f = the force that caused penetration of 20mm.

Alternatively;

- 1) Carry out the ACV test with 50KN, 100KN, 150KN and 400KN.
- 2) Plot the results on a chart with forces on x -axis and the percentage passing 2.36mm on y -axis.
- 3) Join the points with the best-fit curve and read off the force corresponding with 10 % passing 2.36mm sieve as the TFV.



Compression Machine

3.5. Aggregate Impact Value (AIV)

The AIV test is used to measure resistance of aggregate to impact. It is commonly carried out on the 14 – 10mm fraction; however, 20 – 14mm or 10 – 6.3mm fractions also may be used. The chosen fraction can be tested in a dry condition or soaked condition.



AIV Apparatus

Test procedure:

- 1) Obtain the required fraction by sieving aggregate on the specified sieves (e.g. 20 – 14mm, 14 – 10mm or 10 – 6.3mm).
- 2) Fix sample cup on the base plate of the AIV frame.
- 3) Fill aggregate in the cup to overflow and tamp it with 25 strokes of the tamping rod.
- 4) Level the surface by rolling the tamping rod over the cup (remove any projecting particles and fill depressions by hand).
- 5) Apply 15 blows of the AIV hammer on the aggregate surface.
- 6) Remove the mould and place it in a clean tray, then remove the sample by hammering gently on the outside of the cup.
- 7) Brush the cup in the tray and take the weight of the sample (*m1*).
- 8) Sieve the sample on 2.36mm for 14 – 10 fraction (or on 3.35mm for 20 – 14 fraction and on 1.7mm for 10 – 6.3 fraction).
- 9) Weigh the material retained on the separating sieve (*m2*).

Calculations:

$$\text{Material passing the separating sieve} = m1 - m2$$

$$AIV = \frac{(m1 - m2) \times 100}{m1}$$

Note: The AIV of weak aggregates might mislead, especially if fines produced are more than 20%. Therefore, it is recommended to apply fewer blows (say 8, 10 or 12) and a *Modified Aggregate Impact Value* (MAIV) calculated as follows:

$$* MAIV = \frac{\% \text{ fines} \times 15}{\text{Applied number of blows}} \quad \text{[*Introduced by Hosking and Tubey]}$$



Dropping the hammer

Example:

Sample no.	1	2	3	Average
Total weight of sample (<i>m1</i>)	471.1	457.2	459.3	24.6
Wt. Retained on the sieve (<i>m2</i>)	358.0	344.7	344.0	
Wt. Passing separation sieve (<i>p</i>)	113.1	112.5	115.3	
AIV = (<i>p</i> × 100) / <i>m1</i>	24.0	24.6	25.1	

3.6. Los Angeles Abrasion (LAA)

The LAA test measures resistance of aggregate to abrasion (i.e. hardness), by subjecting aggregate particles (mixed with specific number of steel spheres) to 500 revolutions in a rotary steel drum.

The applicable aggregate fractions are:

Group A: Mix (37.5 – 25), (25 – 19), (19 – 12.5) and (12.5 – 9.5) mm.

Group B: Mix (19 – 12.5) and (12.5 – 9.5) mm.

Group C: Mix (9.5 – 6.3) and (6.3 – 4.75) mm.

Group D: Take (4.75 – 2.36)

Test procedure:

- 1) Sieve the aggregates as per the above groups and wash them.
- 2) Obtain about 5000g from each group (i.e. combine 1250g from each fraction for group A; 2500g from each fraction for group B and C; and 5000g from group D) and record the weight ($m1$).
- 3) Put each group in the Los Angeles abrasion machine and add: 12 spheres for group A, 11 spheres for group B, 8 spheres for group C and 6 spheres for group D and allow the drum to rotate 500 revolutions.
- 4) Then remove the sample, sieve it on 1.7mm sieve and weigh the material retained on 1.7mm sieve ($m2$).

Calculations:

$$\text{Material passing 1.7mm} = m1 - m2$$

$$LAA = \frac{(m1 - m2) \times 100}{m1}$$

Example:

Aggregate Sizes (mm)	Group A (12 spheres)	Group B (11 spheres)	Group C (8 spheres)	Group D (6 spheres)
37.5 - 25.0	1251.4			
25.0 - 19.0	1249.8			
19.0 - 12.5	1250.7	2512.7		
12.5 - 9.5	1253.9	2521.3		
9.5 - 6.3			2514.3	
6.3 - 4.75			2520.9	
4.75 - 2.36				5011.3
Wt. of total sample ($m1$)	5005.8	5034.0	5035.2	5011.3
Wt. retn. on 1.7mm ($m2$)	3554.1	3825.8	3675.7	3457.8
Wt. passing 1.7mm	1451.7	1208.2	1359.5	1553.5
$LAA = 100 \times (m1 - m2) / m1$	29	24	27	31
Average (%)	28			



LAA Machine



Coral aggregate (soft)

3.7. Sulphate Soundness (SS)

Sulphate soundness test measures the effect of salts on aggregate particles. The effect is measured as the loss in aggregate weight after repetitive drying and soaking the aggregate in *Sodium* or *Magnesium* sulphate solution.

The applicable sulphate solution is prepared as follows;

Sodium sulphate solution: is made up of 225g of Sodium sulphate and 1 litre of water (is supposed to have a specific gravity of 1.151 – 1.174 when ready for use).

Magnesium sulphate solution: is made up of 350g of Magnesium sulphate and 1 litre of water (is supposed to have a specific gravity of 1.295 – 1.308 when ready for use).

Test procedure:

- 1) Obtain the sample by quartering or riffing a large quantity of aggregate.
- 2) Separate the sample into Fines (passing 4.75mm) and Coarse (retained on 4.75mm).
- 3) Carry out grading of the two parts separately (as if each part is a complete sample).
- 4) Wash the fine part on 0.300mm sieve and dry it in oven.
- 5) Separate the fine part into 4.75 – 2.36, 2.36 – 1.18, 1.18 – 0.600, 0.600 – 0.300 and take at least 100g from each fraction (*m1*).
- 6) Wash the Coarse part on 4.75mm sieve and dry it in oven.
- 7) Separate the Coarse part into 63 – 50, 50 – 37.5, 37.5 – 25, 25 – 19, 19 – 12.5, 12.5 – 9.5, 9.5 – 4.75 mm and take about 1000g from each fraction (*m1*).
- 8) Put each fraction in a separate container and add the specified sulphate solution to cover the samples.
- 9) Soak the test samples for 16 to 18 hours and then decant the solution gently without losing the particles.
- 10) Allow the test samples to drain for 15 minutes, then dry them in oven to constant weight (24 hrs is not necessary). Repeat soaking and drying five times (cycles).
- 11) After the 5th cycle (of soaking and drying), allow the samples to cool and wash them thoroughly with warm water (at 45 °C).
- 12) Dry the samples in oven to constant weight and sieve them on the separation sieves listed in table 3.1.
- 13) Determine and record the weights of the retaining materials (*m2*).



Sound aggregate



Unsound aggregate



Rock Source (Quarry)

Table 3.1 – Separation sieves for Sulphate Soundness test

Fraction (mm)	Separation sieve
63 – 50 and 50 - 37.5	31.5 mm
37.5 – 25 and 25 - 19	16.0 mm
19 - 12.5 and 12.5 - 9.5	8.0 mm
9.5 - 4.75	4.0 mm
4.75 - 2.36	2.36 mm
2.36 - 1.18	1.18 mm
1.18 - 0.600	0.600 mm
0.600 - 0.300	0.300 mm

Calculations:

$$\% \text{ Passing designated sieves} = \frac{(m1 - m2) \times 100}{m1}$$

$$\% \text{ Loss} = \frac{\% \text{ Passing designated Sieve} \times \text{Grading of Sample (\%)}}{100}$$

Example:



Aggregate production

Type of aggregate	Aggregate Fraction (mm)	Grading of sample	Wt. before test (g)	Wt. after test (g)	% Passing	% Loss
Coarse	63 - 50.0 50 - 37.5	0	-	-	-	-
	37.5 - 25 25.0 - 19	4.5	987.6	976.3	1.14	0.05
	19 - 12.5 12.5 - 9.5	69.1	1003.3	1000.9	0.23	0.16
	9.5 - 4.75	26.4	300.6	299.3	0.42	0.11
	Total	100				0.32
Fines	4.75 - 2.36	55.6	102.83	96.20	6.45	3.59
	2.36 - 1.18	10.6	102.33	94.48	7.67	0.81
	1.18 - 0.600	6.6	104.00	93.37	10.22	0.67
	0.600-0.300	4.2	100.30	88.10	12.16	0.51
	Passing 0.300	23.0	-	-	-	-
Total	100				5.58	

3.8. Organic Impurities

Presence of organic impurities in aggregates (especially natural sand) affects the setting time and hardening of concrete and may also cause deterioration of concrete or pop-outs.

To test the organic impurities in fine aggregate, the following stuff is used:



Sodium hydroxide

Test reagent: a solution made up of 3-parts Sodium hydroxide (NaOH) and 97-parts water.

Standard solution: a solution made up of 0.25g of Potassium dichromate ($K_2Cr_2O_7$) in 100ml of concentrated Sulfuric acid. It is used as a reference colour for classifying the sample solution after adding the reagent.

Colour plate: a small plastic plate with different colour slots, used to classify the colour of sample solution as a substitute for the standard solution.

Test procedure:

- 1) Obtain a test sample of about 450g by quartering or riffing a large quantity of fine aggregate (sand).
- 2) Dry the sample to constant weight (air-drying is recommended).
- 3) Fill a calibrated glass bottle to 130 ml with the dry sample of sand.
- 4) Add the test reagent (Sodium hydroxide solution) until the total volume of sand and solution reaches 200 ml.
- 5) Close the glass bottle and shake it vigorously for few minutes.
- 6) Allow the sample to stand undisturbed for 24 hours and compare the colour of the sample solution with the colours on the colour plate or with the standard solution.
- 7) Then, translate the colour as follows;



Colour Plate

<i>Greenish colour</i>	– Excellent material	} STANDARD
<i>Lime colour</i>	– Good material	
<i>Orange colour</i>	– Standard material	
<i>Yellow colour</i>	– Poor material	} POOR
<i>Red colour</i>	– Very poor material	

- 8) Record and report the test result as either STANDARD or POOR.

3.9. Clay lumps and friable particles

Clay lumps are small soil balls, which visually look-like gravel or aggregate particles, but soften and dissolve in water or liquids. Friable particles are granular particles which lose bond and break up (crumble) in water or liquids.

Presence of the dissolving or crumbling particles in an aggregate group affects density, strength and durability of a mix made with the aggregate. As such weak particles crumble during rolling or disintegrate due to moisture; they leave pockets and form weak planes in a concrete structure or pavement layer.

To test such defective particles, the aggregate fractions are soaked in water and squeezed by fingers to dissolve or break up the lumps and friable particles.



Typical friable particles

Test procedure:

- 1) Divide aggregate by quartering or riffing to obtain test sample.
- 2) Dry the sample in oven (set at 105 – 110° C) to constant weight.
- 3) Allow the sample to cool then determine its weight (m_1).
- 4) Place the sample in a clean container, add sufficient water to cover the sample and allow it to soak for 24 hours.
- 5) After soaking, roll and squeeze the aggregate particles with the thumb and forefinger.
- 6) Wash the sample on 4.75mm sieve for fraction larger than 9.5mm, on 2.36mm sieve for 9.5 – 4.75mm fraction or on 0.850mm sieve for 4.75 – 1.18mm fraction.
- 7) Dry the washed sample in oven (set at 105 – 110 °C) to constant weight.
- 8) Allow the sample to cool down (to room temperature) then determine its weight (m_2).

Calculations:

$$\text{Clay lumps and Friable particles} = \frac{(m_1 - m_2) \times 100}{m_1}$$

Example:

Sample no.	1	2	3	Average
Weight of sample before test (m_1)	790.8	800.6	813.2	1.2
Weight of sample after test (m_2)	781.6	792.3	801.8	
Weight passing separation sieve	9.2	8.3	11.4	
Clay lumps & friable particles $100 \times (m_1 - m_2) / m_1$	1.2	1.0	1.4	



Graded aggregate (CRS or CRR)

3.10. Material finer than 0.075mm

Finer materials (especially plastic clays and silts) sometimes lodge in the aggregate cavities or on the surface; hence, affecting the bond of aggregate with bitumen or cement paste. On the other hand, such finer materials increase water demand for a concrete mix, resulting into a low strength concrete.

To test presence of such deleterious materials, aggregate fraction is immersed in water (to disperse the finer materials) and decanted on the 0.075mm sieve. Then, the loss in weight obtained after decantation is counted as the amount of materials finer than 0.075mm. The applicable terms in the test include the following;

Decantation: removal of suspended materials by tilting a container gently without disturbing the settled particles.

Suspensoid: a solution of very fine particles dispersed throughout a liquid.

Test procedure:

- 1) Divide aggregate by riffing or quartering to obtain the sample.
- 2) Dry the sample in oven (at 105 – 110 °C) to constant weight.
- 3) Allow the sample to cool and determine its weight as m_1 .
- 4) Place the sample in a pan and add water to cover the sample.
- 5) Agitate the sample to bring dispersed particles into suspension.
- 6) Decant the suspended material on 0.075mm sieve.
- 7) Add water again, agitate the sample and decant the suspension. (Repeat this step until water is free of suspensoid).
- 8) Dry the sample in oven to constant weight.
- 9) Allow the sample to cool and then determine its weight as m_2 .

Calculations:

$$\text{Material finer than 0.075mm} = \frac{(m_1 - m_2) \times 100}{m_1}$$

Example:

Sample no.	1	2	3	Average
Weight of sample before test (m_1)	500.1	510.5	498.9	2.0
Weight of sample after test (m_2)	490.1	499.7	490.1	
Weight passing the sieve ($m_1 - m_2$)	10.0	10.8	8.8	
Clay lumps & friable particles $100 \times (m_1 - m_2) / m_1$	2.0	2.1	1.8	



Variety of aggregate particles



Clean aggregate particles

3.11. Lightweight pieces

Presence of porous and light pieces (e.g. coal, mica, etc.) in the aggregate group affects the density, strength and durability of a mix made with such aggregate.

To measure the presence of suchlike pieces, aggregate particles are immersed in a heavy liquid (with higher specific gravity than water) and floating materials decanted and weighed as the lightweight pieces. Heavy liquid may be made by dissolving the following compounds in water:

- o Zinc Chloride (for SG less than 2.0)
- o Zinc Bromide (for SG less than 2.4)

Sample preparation:

- o Sieve fine aggregate on 0.300mm sieve and discard the material passing the sieve.
- o Sieve coarse aggregate on 4.75mm sieve and discard the material passing the sieve.

Test procedure:

- 1) Divide the aggregate to obtain the representative test sample.
- 2) Dry the sample in oven (at 105 – 110 °C) to constant weight.
- 3) Allow the sample to cool and determine its weight as m_1 .
- 4) Bring the sample to saturated-surface dry condition (or add amount of water equal to its percentage of water absorption).
- 5) Put sufficient amount of heavy liquid in a clean container and immerse the sample into the liquid.
- 6) Agitate the sample to bring floating materials into suspension.
- 7) Decant the suspension on 0.300mm sieve and collect the floating materials in another container.
- 8) Return the decanted liquid to the sample and agitate the sample by stirring to bring floating materials into suspension.
- 9) Repeat step 7) and 8) until the liquid is free of floating materials.
- 10) Wash the floating materials with water to remove heavy liquid.
- 11) Dry the floating materials and then determine its weight as m_2 .

Calculations:

$$\% \text{ Lightweight pieces} = \frac{m_2 \times 100}{m_1}$$

Recommended weight of sample for Coal and lignite test:

200g for 0 – 4.75mm size.

3kg for 0 – 20mm size.

5kg for 0 – 37.5mm size.

10kg for 0 – 75mm size.

3.12. Acid-soluble materials

Presence of acid-soluble materials in the aggregate mass may affect durability of the aggregates and structures exposed to a chemical environment.

In testing the acid-soluble materials, aggregate particles are soaked in *diluted hydrochloric acid* solution and percentage loss in aggregate weight is calculated and reported as the quantity of acid-soluble materials.

Test procedure:

- 1) Dilute 360ml of concentrated *hydrochloric acid* (with relative density of 1.18) with distilled water to make 1 litre of solution.
- 2) Divide the aggregate to obtain about 50g of test sample and record its weight as m_1 .
- 3) Dry a filter paper and record its weight as m_2 .
- 4) Put the test sample into a 500ml conical flask, add 25ml of diluted hydrochloric acid solution (4N) and agitate the flask.
- 5) Then, keep adding more acid solution while agitating the flask until bubbling ceases.
- 6) When no further bubbling occurs on adding more acid solution, heat the flask to about 80 °C (do not exceed boiling point).
- 7) Decant the hot acid solution slowly on the filter paper without disturbing the aggregate particles.
- 8) Wash the sample by adding 50ml of hot water (below boiling point), agitating the flask and decanting the solution on the filter paper (repeat washing 5 rounds to remove the acid).
- 9) Then, wash the sample and filter paper in a tray with cold water and dry them in oven to constant weight.
- 10) Allow the sample and filter paper to cool and record the weight (of sample + filter paper) as m_3 .

Calculations:

$$\text{Acid-soluble materials (\% loss)} = \frac{(m_1 + m_2 - m_3) \times 100}{m_1}$$

Where:

m_1 = weight of sample before test

m_2 = weight of filter paper before test

m_3 = weight of sample and filter paper after test



Hydrochloric acid



Conical flask

3.13. Specific gravity (SG)

Specific gravity is the ratio of density of a *solid particle* to the density of *distilled water*. In addition, the test measures impermeability of aggregate particles (water absorption).

It is a useful data for computing the volume of aggregate and voids in different mixes (especially concrete and asphalt). Generally, the three parameters given by the test are:

Bulk specific gravity:- the density of permeable particle (including permeable and impermeable voids normal to the particle).

Apparent specific gravity:- the density of impermeable portion of particle (excluding permeable and impermeable voids normal to the particle).

Water absorption:- the amount of water absorbed by solid particle (expressed as percentage of dry mass of the particle).

Test procedure:

a) Fine aggregate (passing 4.75mm or 5.0mm)

- 1) First, dry the sample in oven (at 105 – 110 °C).
- 2) Allow the sample to cool and put it in a clean container.
- 3) Add water to the sample and allow it to soak for 15 – 19 hours.
- 4) Then, decant the excess water with care to avoid loss of fines.
- 5) Spread the sample on a flat surface exposed to warm air until the sample achieves saturated-surface dry condition (*s.s.d.*).
- 6) Fill sample in the cone in four equal layers and give the layers 10, 10, 3 and 2 drops of tamping rod respectively.
- 7) Remove loose materials around the cone and lift up the cone gently (if the material slumps slightly, means it is at a saturated-surface dry condition; and if retains the cone shape means it is still wet; therefore, should be dried a little bit).
- 8) Partially fill pycnometer with water and add about 500g of the saturated-surface dry sample (*m1*).
- 9) Add more water and shake pycnometer to remove air bubbles.
- 10) Then, add more water in the pycnometer to its calibration mark and take the overall weight of pycnometer + sample + water (*m2*).
- 11) Remove the sample from pycnometer, decant water and dry it in oven to constant weight.
- 12) After drying, allow the sample to cool and record its weight (*m3*).
- 13) Fill pycnometer with water to its calibration mark and determine the weight (*m4*).



Glass Pycnometer



Cone and Tamping rod



SG basket

Calculations:

- Bulk specific gravity (oven-dry) = $\frac{m_3}{m_4 + m_1 - m_2}$
- Bulk specific gravity (s.s.d) = $\frac{m_1}{m_4 + m_1 - m_2}$
- Apparent specific gravity = $\frac{m_3}{m_4 + m_3 - m_2}$
- Water absorption = $\frac{(m_1 - m_3) \times 100}{m_3}$

b) Coarse aggregate (retained on 4.75mm or 5.0mm)

- 1) Obtain the test sample by riffing or quartering the aggregates.
- 2) Immerse (soak) the sample in water for about 15 hours.
- 3) Remove sample from water and wipe it with towel to bring it to a saturated-surface dry condition.
- 4) After wiping the sample, take its weight in air (m_1).
- 5) Put the sample in a wire basket (with smaller opening than the particle size) and take its weight in water (m_2).
- 6) Dry the sample in oven (at 105 – 110 °C) then record its weight in air (m_3).

Calculations:

- Bulk specific gravity (oven dry) = $\frac{m_3}{m_1 - m_2}$
- Bulk specific gravity (s.s.d) = $\frac{m_1}{m_1 - m_2}$
- Apparent specific gravity = $\frac{m_3}{m_3 - m_2}$
- Water absorption = $\frac{(m_1 - m_3) \times 100}{m_3}$



Weighing bench

3.14. Sand equivalent (SE)

Sand equivalent test determines the proportion of plastic clays, silts or amount of dust in fine aggregates for concrete.

To conduct the test, a working solution of *Calcium chloride* is used to disperse clay and dust into suspension; and the height of sand column (sand reading) is measured and compared to the height of suspension (clay reading). The test includes the following terms;

Working solution:- is made up of 22ml of stock Calcium chloride solution to 1 litre of water.

Sand reading:- top level of sand column.

Clay reading:- top level of clay suspension.

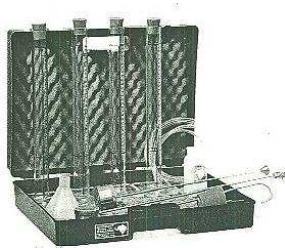

Sand Equivalent test set

Test procedure:

- 1) Fill a graduated cylinder with 100ml of working solution.
- 2) Add about 85ml of sand (the material passing 4.75mm sieve).
- 3) Tap the bottom of cylinder to release entrapped air bubbles.
- 4) Allow the sample to soak for 10 minutes, and then shake it from end to end in a horizontal motion in 90 cycles within 30 seconds (1 cycle is forward and backward motion).
- 5) After shaking, put the cylinder upright on the table and remove the stopper without dropping the suspension.
- 6) Insert the irrigator tube in the material to the bottom of the cylinder by twisting action, while working solution flows from the irrigator tip.
- 7) Then, twist the irrigator in the material to flash the fine materials into suspension until the cylinder is filled to the calibration mark.
- 8) Allow the sample to stand undisturbed for 20 minutes after removing the irrigator.
- 9) At the end of 20th minute, record the clay reading (the top level of suspension) (*b1*).
- 10) Lower the weighed footing to the top of sand column and record the height of sand column (below the footing) (*b2*).

Calculation:

$$\text{Sand equivalent (SE)} = \frac{\text{Sand reading (b2)} \times 100}{\text{Clay reading (b1)}}$$

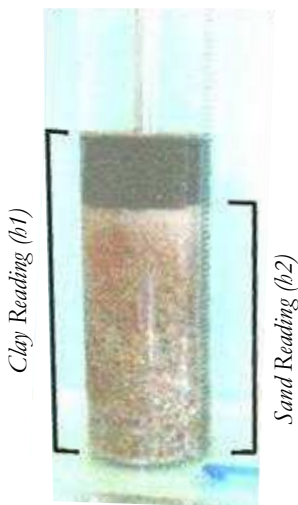

Clay and Sand Readings

Chapter 4

Concrete Materials

Brands of local Cement



Concrete is a mixture of cement, aggregate and water; which when fresh, forms a paste that later on sets and hardens by means of hydration reactions to form a solid (stone-like) material.

4.1. Cement

According to BS 12, cement is hydraulic binder (finely ground inorganic material), which when mixed with water forms a paste that sets and hardens by means of hydration reactions and processes; and which after hardening retains its strength and stability even under water.

a) Type of cement:

However there are many types of cement for different construction purposes, the most frequently used types are:

- *Ordinary Portland Cement (OPC)*:– used in safe environment (free from chemical attack).
- *Sulphate Resisting Portland Cement (SRPC)*: – used in sulphate exposure (e.g. in sea waters, chemical industries, etc).
- *Rapid Hardening Portland Cement (RHPC)*: – used where quick strength is required.

b) Composition of cement:

Portland cement is a mixture of limestone and clay materials, burnt into a rotary kiln at about 1500°C and then ground to form a clinker (ash). Clinker is again ground down into a finer powder (smaller than 0.02mm) and *gypsum* (mineral consisting of hydrated calcium sulphate) added to control the rate of setting.

The principal compounds of Portland cement are:

Tricalcium silicate (C_3S)

Dicalcium silicate (C_2S)

Tricalcium aluminate (C_3A)

Tetracalcium aluminoferrite (C_4AF)

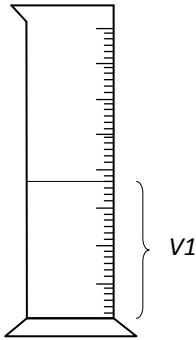

Volume of Kerosene before displacement

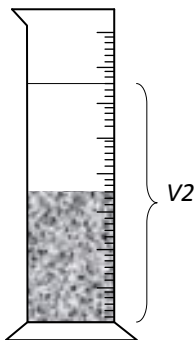

Volume of Kerosene after displacement

c) Properties of cement:

Portland cement is a finely ground powder, having a bulk density of about 1500 kg/m^3 and a specific gravity of about 3.150. When mixed with water, cement forms a paste that sets and hardens by means of *hydration process* (chemical reaction between cement compounds and water molecules, which generate heat known as *heat of hydration*).

Evaluations of cement properties require sophisticated laboratory equipment and skills. However, since cement is manufactured under controlled process, most of the tests are conducted at the factory laboratory and supplied with cement batches as quality document (*certificate of quality*). Therefore, very few tests are normally conducted at the site laboratory.

▪ Specific gravity:

The specific gravity of cement can be estimated at site using kerosene [**Thomas Larson**; *Portland Cement and Asphalt Concretes*].

Test Procedure:

- 1) Fill a small-calibrated measuring cylinder with reasonable volume of kerosene ($V1$).
- 2) Weigh appropriate amount of cement that can settle in and give visible displacement of the kerosene (M_c).
- 3) Fill cement into the cylinder by funnel to avoid dislodging.
- 4) Agitate the cylinder to remove air bubbles and ensure that cement is properly dispersed in the kerosene.
- 5) Allow cement to settle in the kerosene for few seconds, then, take the reading of the liquid ($V2$) and calculate specific gravity as:

$$\text{Specific gravity} = \frac{\text{Weight of cement}}{\text{Displaced volume}} = \frac{(M_c)}{(V2 - V1)}$$

▪ Setting time:

The interval of time from when water is added up to when cement paste starts to become rigid is known as *initial setting time*; and the interval of time from when water is added up to when cement paste become rigid enough to resist light pressure is known as *final setting time*.

Test Procedure:

- 1) Mix 650g of cement with a measured quantity of water to produce a plastic (mouldable) paste.



Vicat Apparatus

- 2) Take the cement paste, form a ball and toss it six times from one hand to another (placed 150mm apart).
- 3) Press the ball into a Vicat ring through the larger end.
- 4) Remove excess material at the larger end by single slash of a hand.
- 5) Slice the smaller end by sharp edge of a trowel and smooth the top part without pressing the paste.
- 6) Put the paste under Vicat apparatus, bring the plunger (10mm dia.) in contact with the sample and record the initial reading.
- 7) Release the plunger immediately and record the reading.
- 8) Repeat the test with varying percentages of water until a penetration of about 10mm (9mm – 11mm) is obtained. Record that percentage as the moisture content for *normal consistency*.
- 9) Mix another 650g of cement at normal consistency (with the moisture content obtained in step 8).
- 10) Follow step 2) to 5) above.
- 11) Put the paste under Vicat apparatus, bring the needle (1mm dia.) in contact with the surface of the paste, penetrate the paste immediately and record the reading.
- 12) Continue to make penetration after every 15 minutes until a penetration less than 25mm is obtained
- 13) Draw a graph of time against penetrations, interpolate the time corresponding with penetration of 25mm and record it as the *initial setting time*.
- 14) Continue with the penetration process after every 15 minutes until no visible penetration occurs on the surface of the sample; record the interval of time from mixing up to when the needle fails to penetrate the sample and report it as the *final setting time*.

d) Cement handling:

The following conditions should be observed when handling cement:

- Cement should not be touched with bare hand or foot.
- Cement should be stored where it does not come into contact with moisture, to avoid caking (hydration reaction).
- Cement stock should be covered by waterproof sheets.
- Storage space should be at least 150mm off the ground and should allow air circulation.
- Punctured bags should not be used for permanent works.
- Cement should not stay on site for more than six weeks.

4.2. Aggregate



Crushed Aggregate

Aggregate is used in concrete to expand the mix volume, to control shrinkage properties and to contribute strength. As a result, quality of aggregate has great influence on the strength, workability, permeability and durability of concrete mixes.

Concrete aggregate should be clean and strong enough to resist forces and exposure conditions. The particles should be hard, dense and free from excess dust. Soft aggregates (e.g. coral, sandstone, mudstone, etc.) should not be used for high-strength concrete. Therefore, careful selection of rock source is very important, as quality of aggregates depends on the geological composition of the rock.

However some researchers recommend the use of marine aggregates for concrete after washing with clean water due to concentration of salts (sulphate and chloride), the suitability of such material should be carefully investigated and proved by laboratory testing (if washing has significantly reduced the injurious substances to an acceptable amount).

Table 4.1 – Basic properties of aggregate for concrete

Property:	Description:	Test:
Cleanliness	Free of deleterious matters (clay lumps, coal, mica, shale, alkali, oil, etc.)	- Organic impurities - Lightweight pieces - Material finer than 0.075mm - Shale content - Sand equivalent
Strength	Ability to resist crushing	- ACV or TFV
Hardness	Ability to resist wear	- LAA
Toughness	Ability to resist impact	- AIV
Soundness	Ability to resist exposure conditions (e.g. chemicals)	- Sodium or Magnesium Soundness
Shape	Particle dimensions	- FI and EI
Grading	Particle size distribution	- Sieve analysis



River Sand



Coral Aggregate (soft)

Grading and shape of aggregate particles are also important due to their effect on the mix workability and density. Smooth and rounded particles produce better workability but develop weak internal friction and poor bond with cement paste. Flaky and elongated particles produce poor workability and particle interlock. Coarse grading demands low water/cement ratio and produce poor workability, while fine grading increases water demand for a better workability, resulting in strength reduction.

Therefore, aggregate particles should be cubic, rough and well graded (from fine to coarse) to enable workability, proper bond and adequate density.

Table 4.2 – Grading limits for fine aggregate (BS 882)

Sieve size (mm)	Overall limits	Additional limits		
		<i>Coarse</i>	<i>Medium</i>	<i>Fine</i>
10	100	-	-	-
5	89 – 100	-	-	-
2.36	60 – 100	60 – 100	65 – 100	80 – 100
1.18	30 – 100	30 – 90	45 – 100	70 – 100
0.600	15 – 100	15 – 54	25 – 80	55 – 100
0.300	5 – 70	5 – 40	5 – 48	5 – 70
0.150	0 – 15	-	-	-



Granite Aggregate (hard)

Table 4.3 – Grading limits for coarse aggregate (BS 882)

Sieve size (mm)	Nominal size of aggregate		
	<i>40mm – 5mm</i>	<i>20mm – 5mm</i>	<i>14mm – 5mm</i>
50	100	-	-
37.5	90 – 100	100	-
20	35 – 70	90 – 100	100
14	-	-	90 – 100
10	10 – 40	30 – 60	50 – 85
5	0 – 5	0 – 10	0 – 10

4.3. Water

Water to be used for concrete should be clean and free from aggressive compounds such as; oil, acid, alkali, salt, sugar, organic matter and other compounds that may attack concrete components. Such injurious substances may affect the setting time, strength, bond and shrinkage of concrete; or may cause corrosion of reinforcements.

Generally, drinking water is the mostly recommended water for concrete production and curing. Sources like river, lake or boreholes may be used if tested and proved to be suitable for concrete production. However, the use of seawater for mixing and curing concrete is still contradicting due to presence of salts (*sodium chloride*, *magnesium sulphate* and *potassium*). While some researchers warn on the risk of reinforcement corrosion, some do associate the corrosion of reinforcement with permeability and insufficient concrete cover, and suggest the use of low water/cement ratio and high density when seawater is unavoidable. On the other hand, some standards (e.g. Indian Standard IS 456 of 2000) permit the use of seawater for mixing and curing mass concrete where such use is unavoidable.

Despite these convincing opinions, the use of seawater for concrete or for building mortars is adverse also due to the effect of frequent dampness (efflorescence) on structures and strength reduction (by about 10%).

Some of the aggressive compounds in water and their degree of attack are shown in table 4.4 below:

Table 4.4 – Aggressive Compounds for Concrete (DIN 4030)

Compounds		Degree of attack	
		Severe	Very Severe
Acids	<i>pH</i>	6.5 – 5.5	5.5 – 4.5
Ammonium (NH ₄ ⁺)	<i>mg/l</i>	15 – 30	30 – 60
Magnesium (Mg ²⁺)	<i>mg/l</i>	300 – 1000	1000 – 3000
Sulphates (SO ₄ ²⁻)	<i>mg/l</i>	200 – 600	600 – 3000
Lime-dissolving Carbonic acid (CO ₂)	<i>mg/l</i>	15 – 40	40 – 100
Chloride (Cl)	<i>mg/l</i>	More than 500	



Lake – Potential Water Source



Water Test Kit

4.4. Reinforcements

Generally, reinforcements are steel bars, plastic or glass fibers incorporated in concrete to provide tensile strength. Concrete is not elastic material, therefore, it cracks and breaks suddenly when stretched (pulled apart) by the imposed loads.

However development of technology has led to the application of glass and plastic fibres in concrete as reinforcements, steel bars are still the most applicable material for reinforcing the loaded concrete members. Steel is very strong in both tension and compression; therefore, its use in concrete prevents concrete member from stretching. Additionally, the use of reinforcement helps to hold the cracked portions together and allows the concrete structures to be moulded in a desired shape without fear of failure.



Plain bar



Ribbed bar

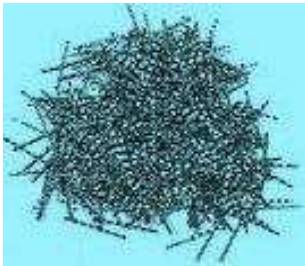

Steel fibres



Plastic fibres

a) Un-reinforced concrete

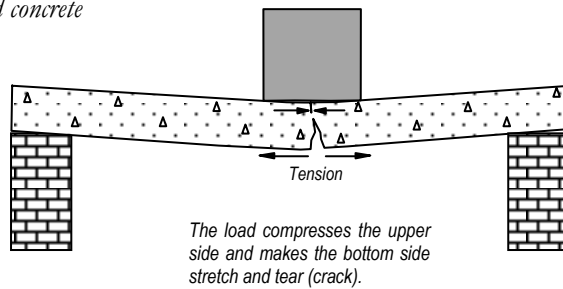

b) Reinforced concrete

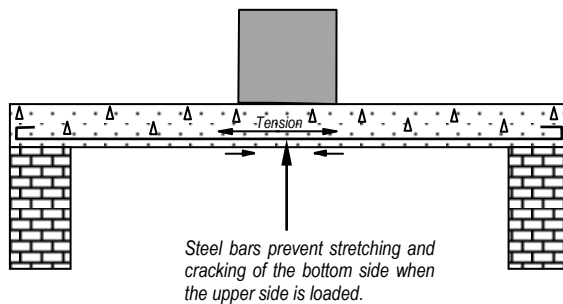
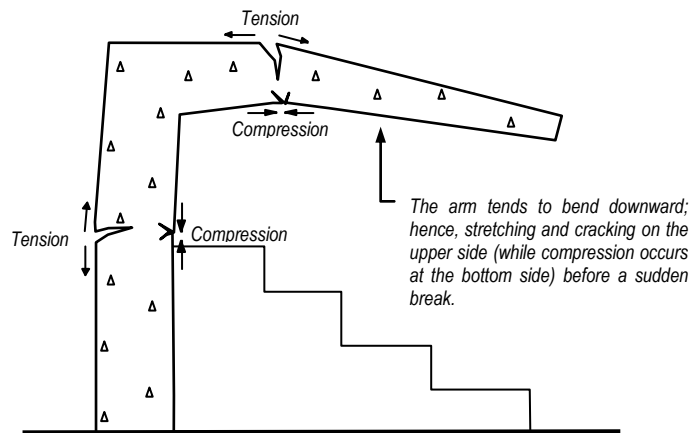

Figure 2: Tension in a concrete member with end support.



Un-reinforced concrete structure

a) Un-reinforced concrete



b) Reinforced concrete

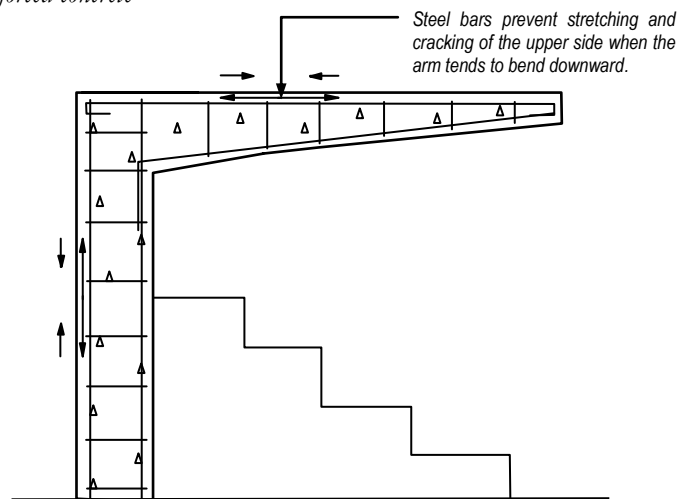

Figure 3: Tension in a concrete member with one end support.



Reinforced concrete structure

While some bars are made plain (smooth) some are ribbed to improve bond with concrete, however, their general performance depends on the following factors;

- o Type (or grade) of steel.
- o Size and quantity.
- o Shape and anchorage.
- o Position and spacing.
- o Cleanliness and cover.







Reinforcement for a bridge pier

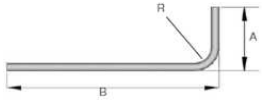
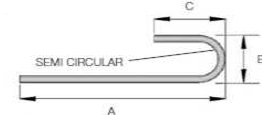
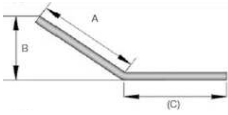

Reinforcement for cast in-situ piles

Table 4.5 – Typical bar bending shapes and lengths (BS 8666: 2000)

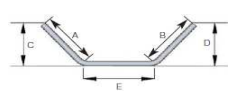
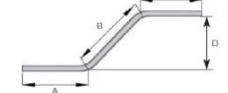
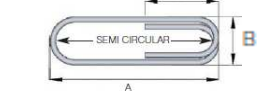
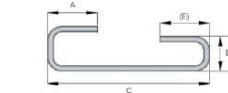
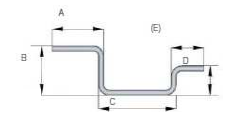
Shape	Total length
	$L = A$
	$L = A+B-0.5r-d$
	$L = A+B-0.5r-d$
	$L = A+0.57B+C-1.57d$
	$L = A+C$
	$L = A+B+C-r-2d$
	$L = A+B+E$
	$L = A+B+C$
	$L = 2A+3B+17d$
	$L = A+B+C+D+E-2r-4d$
	$L = A+B+C+D+E-2r-4d$
<p>$r = \text{bar radius}$ $d = \text{bar diameter}$</p>	

4.5. Admixtures

Mineral and chemical admixtures (or additives) are powdery or liquid compounds added to fresh concrete to make it work or behave as desired.

Mineral admixtures such as *fly ash*, which is by-product of coal combustion, *blast furnace slag* (by-product of steel production) or *silica fume* (by-product of silicon and ferrosilicon alloys) are normally added to concrete as cement extenders.

Chemical admixtures are added to a fresh concrete mix to modify its workability, setting time, colour or other physical properties. Generally, chemical admixtures make fresh concrete behave in the desired way;



Typical Accelerator



Typical Retarder



Typical Plasticizer

- *Plasticizers*:- used to increase the workability of fresh concrete with low water/cement ratio. They make concrete more plastic, hence, self-leveling or easy to consolidate and achieve high density. They increase strength of concrete by reducing water demand. The mechanism of plasticizing is not chemical but physical effect of particle dispersion.
- *Accelerators*:- used to speed up the hydration process (to make concrete set quickly), especially when early-strength is required.
- *Retarders*:- used to slow down the hydration process (to allow concrete to work for longer time without setting), especially where casting is done in a difficult environment and goes slowly or where concrete travels a longer distance before casting.
- *Air entrainers*:- used to add some tiny air bubbles in a fresh concrete (to accommodate freeze-thaw expansive pressures). However air entraining increases workability and reduce bleeding, it is also reducing internal friction and density, resulting in a loss of strength by about 5% for every 1% of air entrained.
- *Pigments*:- used to change the colour of concrete for better appearance (non-technical use).
- *Corrosion reducers*:- used to reduce corrosion in the steel bars and wire mesh for longer life.
- *Waterproofers*:- used to reduce permeability and absorption of concrete (by blocking the capillaries or lining them with hydrophobic film).

4.6. Concrete mix

a) Mix components:

Concrete is basically made from cement, aggregate and water. Other components (e.g. admixtures and reinforcements) are specially added to modify or improve some properties of fresh or hardened mix (e.g. workability, setting time, tensile strength, etc).



Fresh Concrete mix

Table 4.6 – Descriptions of concrete components

Component	Function
Cement	Binder and filler for other ingredients.
Aggregate	Mix extender and Strength contributor.
Water	Lubricant and hydration facilitator.
Admixtures	Property modifier.
Reinforcement	Internal support (provides tensile strength)

b) Types of mixes:

Concrete mixes are normally grouped as *mass concrete* and *structural concrete*, depending on the mix applications;

- *Mass concrete*:- a plain mix (without reinforcement). Used for blinding ground surface before application of structural concrete.
- *Structural concrete*:- a mix applied with reinforcements. Used to cast members which bear tensile stress.

However, fresh mixes also could be grouped into three categories;

- *Dry (or stiff) mix*:- a mix without slump. Such mix requires application of rollers (e.g. in pavements, gravity walls, etc.)
- *Plastic mix*:- a mix with slump up to 175mm. Used where the application of tamping equipment or vibrators is possible.
- *Flowing mix*:- a self-leveling mix (with slump higher than 175mm). Such mix is normally poured by concrete pump or tremie pipe in narrow members (e.g. piles); or where the use of tamping equipment or vibrators is impractical.



Reinforced Concrete



Laboratory Mixer

c) Mix design:

Concrete mix design starts with assessment of materials' properties, proportioning the ingredients, conducting laboratory trials and adjusting the proportions to achieve the design target.

However there is a graphical method of carrying out a mix design (as provided in TRRL and Road Note 4), the volumetric ratios, such as 1:3:6 (cement :sand :aggregate) for mass concrete and 1:2:4 for structural concrete is still popular in Tanzania, since the graphical method is somehow complicated for beginners, so is not regularly used in many construction sites. Therefore, most of the material engineers normally make several trials (batched in variable ratios) and adjust cement content to arrive at the specified class of concrete. That may consume time, as target strength is achieved after 28 days.

However, by using past projects' experience on local materials (e.g. type of cement, sand and aggregate) is possible to forecast cement content by weight (kg/m^3) and use the obtained value to convert other ratios into weights. To get a good mix by this method, the specific gravity of each material should be tested and used with the weights to alter the mix volume into a cubic meter (1m^3).

Table 4.7 – Grades of concrete and forecast cement contents

Grade of concrete	Min. cement (kg/m^3)	Mixing ratio	Average slump	Cement class
C15	250	1:3:6	30 mm	32.5N
C20	335	1:2:4	40 mm	
C25	360	1:2:3	50 mm	
C30	400	1:2:2	40 mm	
C35	450	1:1:2	40 mm	



Concrete Sample

Design procedure:

- 1) Evaluate specific gravity of aggregates and use $3150 (\text{kg}/\text{m}^3)$ for cement and $980 (\text{kg}/\text{m}^3)$ for water.
- 2) Adopt cement content for the desired grade from table 4.7.
- 3) Start with *water/cement* ratio of 0.53 (or as specified).
- 4) Calculate weight of sand, aggregate and water by multiplying weight of cement by respective ratios in table 4.7.
- 5) Calculate the volume of each component by dividing the weight by the Specific gravity (i.e. $V = \text{mass}/SG$).



Concrete Truck



Concrete Paver

Weight of each component:

- Wt. of cement (M_c) = Adopt value for the class from table 4.7
- Wt. of sand (M_s) = Wt. of cement x Sand ratio
- Wt. of aggregate (M_a) = Wt. of cement x Aggregate ratio
- Wt. of water (M_w) = Wt. of cement x Water/Cement ratio

Volume of each component:

- Vol. of cement (V_c) = Wt. of cement/SG of cement = ($M_c / 3150$)
- Vol. of sand (V_s) = Wt. of sand/SG of sand = (M_s / SG_s)
- Vol. of aggregate (V_a) = Wt. of coarse/SG of coarse = (M_a / SG_a)
- Vol. of water (V_w) = Wt. of water/SG of water = ($M_w / 980$)

6) Check if the volumes contributed by the materials makes a cubic meter (if not, adjust the weight of sand or coarse aggregates to ensure that the batch is almost 1m^3).

Example:

Grade	Variables	Cement	Sand	Aggreg.	Water	Total
C25	Mixing ratios	1	2	3	0.53	
	Weight (kg/m^3)	360	720	1080	190	2350
	SG (kg/m^3)	3150	2660	2685	980	
	Volume (m^3)	0.11	0.27	0.40	0.19	0.97
	Adjusted Weight	360	745	1130	190	2425
	Volume (m^3)	0.11	0.28	0.42	0.19	1.0

The main points to bear in mind when conducting a mix design and running the laboratory trials are;

- 1) Aggregate may contain *medium size* and *coarse size*, combined in the ratio of 1:4, 1:3 or 1:2 respectively (depending on the grading).
- 2) Proper mixing is done by using small mixers; however, hand mixing also can produce homogeneous mix if carried out thoroughly on a non-absorbent surface.
- 3) Water should be added little by little during mixing in order to control the workability (may require less or more water).



Concrete Hopper

- 4) Adjustment of the weights after the test results is sometimes necessary for the mix to attain proper *strength margin* or desirable *workability*. The thumb rule for cement content is that; an increase of 5kg of cement in a 1m³ results in an increase of 1N/mm² for the hardened mix.
- 5) Workability depends to a great extent on the amount of sand and water used in the mix. Therefore, adjustment should be done carefully, as increase of sand and water lowers the strength of concrete.

d) Mix Properties:

The mix should be dense and workable in order to produce strong and durable concrete that can resist environmental exposure. Such mix should contain a balanced proportion of cement, sand, coarse aggregate and water. Mixes rich in cement are much stronger; however, they are more expensive and prone to shrinkage and thermal cracks (caused by heat of hydration). Therefore, it is restricted that cement content should not exceed 500kg/m³; and if strength requirement dictates the content beyond that limit, then, high strength cement (e.g. 42.5, 52.5, etc.) should be opted for.

Typical recipes for concrete mixes made with local cements (mainly OPC/32.5N), river sand and granite aggregates are as shown below;

Table 4.8 – Typical concrete recipes made with local materials

Strength (N/mm ²)	Proportions (kg/m ³)					
	Cement	Sand	Coarse*	Water	W/C ratio	Slump
15-20	250	700	1250	130	0.52	0-30
20-25	335	590	1250	170	0.51	20-50
25-30	360	560	1245	195	0.54	20-50
30-35	400	520	1225	210	0.53	20-50
35-40	450	490	1210	230	0.51	20-50

*Coarse aggregate may contain two fractions (i.e. *medium size* and *coarse size*).

Source: Various construction projects in Tanzania
(Produced as ‘easy aid’ for beginners who may need guidance)



Concrete Pump

4.7. Workability and Strength

Workability means simplicity of movement or placement of a concrete mix. Fresh concrete should be self-leveling or should pack properly when tamped or vibrated by mechanical tools.

Apart from the vast methods of checking the workability of concrete, the most applicable methods are *slump test* (for plastic mixes), *flow test* (for flowing mixes) and *V-B time* (for stiff mixes). However, the tests of particular interest are the slump and flow tests.



Slump test

a) Slump test

The test is carried out on a steel base plate, using a truncated cone of 300mm high, 200mm diameter at the bottom and 100mm at the top. The test is suitable for plastic concrete mixes (slump less than 175mm) and is conducted within 5 minutes of sampling.

Test procedure:

- 1) Place base plate on a flat surface and hold the cone firmly on it.
- 2) Fill fresh concrete in the cone in three equal layers and tamp each layer with 25 strokes of the tamping rod.
- 3) Overfill the cone a bit and roll the top with the rod to level it off.
- 4) Hold the cone firmly on the plate, clean excess material around the cone and lift it carefully with a uniform upright motion.
- 5) Invert the cone next to the specimen, place the rod or a straightedge over the cone and measure the drop in height.
- 6) Record the drop (slump) to the nearest 5mm and report the type of drop (e.g. *normal*, *collapse* or *shear*).



Measuring the Slump

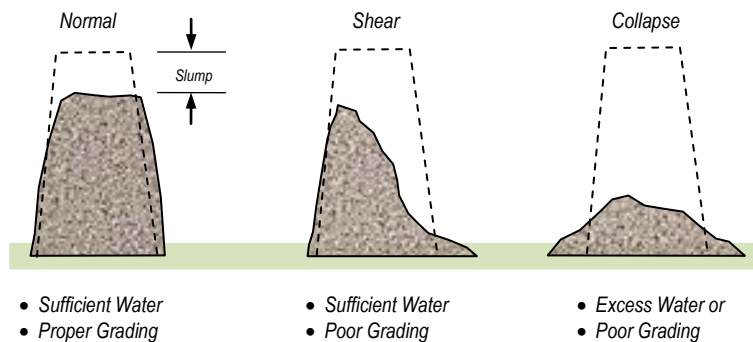

Figure 4: Common types of Slump



Flow Cone and Table

b) Flow test

This is used to determine the workability of flowing concrete (slump greater than 175mm). Mixes of such a high slump are self-leveling and are normally made and poured by concrete pumps, or cast in a confined structure (e.g. cast in-situ piles), where tamping or vibration is impractical.

The test uses a truncated cone (as the slump cone), with 200mm diameter at the bottom, 130mm at the top and 200mm high. The cone is used on a hinged table of 700x700mm.

The slump test is accomplished on the table, then, one side of the table is lifted up (40mm) and allowed to drop freely; and the diameter of the area covered with concrete measured (in mm) and reported as the *flow value*.

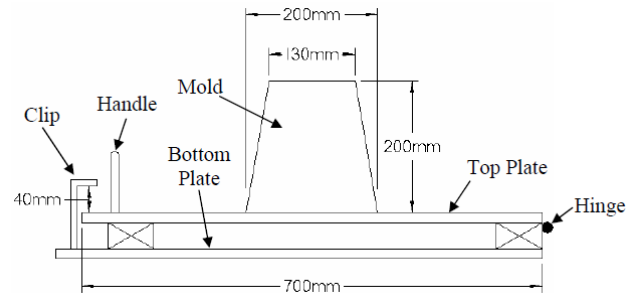
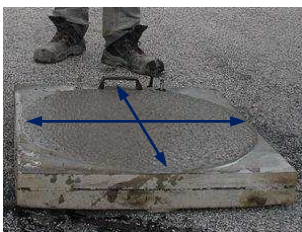

Figure 5: Flow table and cone

Test procedure:

- 1) Wipe inside of the cone and the table with a damp cloth.
- 2) Take a reasonable amount of fresh concrete and mix it well.
- 3) Place the cone on the table (with narrow end upward) and hold it firmly by feet on the table.
- 4) Fill fresh concrete in the cone in two approximately equal layers and tamp each layer with 10 strokes of the tamping rod
- 5) Overfill the cone slightly and roll the top with the rod to level it off.
- 6) Hold the cone firmly on the table and clean excess material around it.
- 7) Lift the cone carefully with a uniform upright motion.
- 8) Lift the table to its limit and drop it freely 15 times over 6 seconds
- 9) Measure the diameter of concrete in two directions (parallel to the edge of the flow table).
- 10) Record average of the two measurements (in mm) as the *flow*.



Directions of Flow measurement



Compacting a concrete cube

c) Making test cubes

The BS standards specify 100 x 100 x 100mm cubes (for aggregate not exceeding 20mm) and 150 x 150 x 150mm cubes (for aggregate less than 40mm) for testing the compressive strength of concrete. The cubes are made as follows:

Procedure:

- 1) Place the moulds on a flat surface (under shed).
- 2) Fill fresh concrete in the moulds in layers of about 50mm and vibrate them until the surface become smooth (do not over-vibrate); or tamp each layer with 25 strokes of the compacting rod for 100mm cubes or 35 strokes for 150mm cubes.
- 3) Smooth the surface with trowel or steel float.
- 4) Remove all surplus materials around the moulds without disturbing fresh concrete.
- 5) Leave the moulds in place for 24 hours before opening the cubes.
- 6) After 24 hours, open the cubes and mark them accordingly.
- 7) Immerse them in water until the specified testing days (preferably, 3, 7 and 28 days).

d) Making test cylinders

The American standards utilize cylinders of 50mm diameter x 100mm high or 150mm diameter x 300mm high for testing the compressive strength of concrete. The cylinders are made as follows:

Procedure:

- 1) Place the cylindrical moulds on a flat surface (under shed).
- 2) Fill fresh concrete in the moulds in 3 layers and vibrate them until the surface become smooth (do not over-vibrate); or tap the outside of the moulds lightly 10-15 times with mallet.
- 3) Smooth the surface with trowel or steel float.
- 4) Remove all surplus materials around the moulds without disturbing fresh concrete.
- 5) Leave the moulds for 24 hours before opening the cylinders.
- 6) After 24 hours, open the cylinders and mark them accordingly.
- 7) Immerse them in water until the specified testing days (preferably, 3, 7 and 28 days or 3, 7, 14 and 28 days).



Making a set of Concrete cubes

e) Concrete strength

However concrete is used in many ways, the dominant loads are often compressive in nature, which by some ways create tensile stress on one side of a member. Therefore, the most common tests for judging the strength of concrete are *Compressive test* and *Tensile splitting test*.



Compression Platens

i) Compressive strength

- 1) Remove the specimen from curing tank and wipe it with a cloth.
- 2) Weigh the specimen and determine its density (*weight/volume*).
- 3) For a cylinder, cap rough surface with a capping compound.
- 4) Center specimen on the lower platen of the compression machine
- 5) Without shock, apply the load until maximum value is achieved.
- 6) Record the maximum load and convert it into Newton (N).

$$\text{Compressive strength (N/mm}^2\text{)} = \frac{\text{Maximum load (N)}}{\text{Surface area (mm}^2\text{)}}$$

Table 4.9 – Strength development of concrete (made with local cement)

Age (days)	Strength Development (% of 28 days' strength)
1	15 %
3	40 %
7	65 %
14	85 %
28	100 %

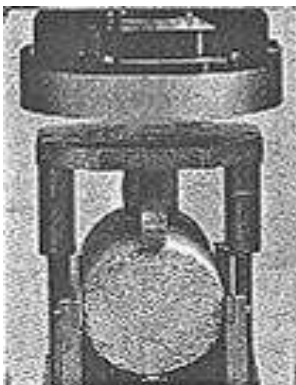

Tensile Splitting Jig

ii) Tensile splitting strength

- 1) Remove specimen from curing tank; wipe it with a cloth to remove surface water and record its diameter (*D*) and length (*l*).
- 2) Weigh the cylinder and determine its density (*weight/volume*).
- 3) Place the cylinder (horizontally) in the jig with packing strips on top and bottom of the specimen.
- 4) Center the jig on the platen of the compression machine
- 5) Without shock, apply the load until the maximum load is achieved
- 6) Record the maximum load and convert it into Newton (N)

Calculation:

$$\text{Tensile splitting strength (N/mm}^2\text{)} = \frac{\text{Maximum load} \times 2}{\pi \times l \times D}$$

4.8. Quality and Durability

The quality of concrete is simply indicated by strength and workmanship. Strength is tested in the laboratory (on cubes or cylinders made from the mix); while workmanship is assessed visually during production. However, the main factors that guarantee quality are:



Good Workmanship

1) *Suitability of materials:*

Suitable cement provides adequate strength and resists ground salts. Hard and strong aggregates reduce the risk of wear and permeability, while suitable water facilitates hydration process without attack to other mix components.

2) *Water/cement ratio:*

The use of minimum amount of water in a concrete mix reduces the amount of voids in the hardened concrete. The proper amount of water required for hydration reaction is equivalent to $\frac{1}{3}$ of the weight of cement (i.e. water/cement ratio of 0.33). Therefore, additional water is normally added to concrete mixes just for workability purposes. As concrete sets; extra water normally evaporates and leaves tiny voids that form planes of weakness in the concrete. So, the more water in the fresh concrete mix the more voids in the hardened concrete.

3) *Workability:*

Workable mix moves easily and consolidates readily; hence, minimizing air voids and plains of weakness in the concrete.

4) *Workmanship:*

The use of proper formwork prevents loss of cement paste, while proper compaction method and good finishing maintain the mix uniformity. Slanting the vibrator, as well as over-compacting or tamping bring more paste on top and push the aggregate to the bottom, hence causing mix segregation.

5) *Curing:*

Favourable temperature and subsequent curing the concrete with specific compounds or covering with *hessian cloth* and spraying water prevent rapid loss of water and facilitate hydration process, resulting in proper strength development.



Poor Workmanship



Proper formwork improves Workmanship



Poor formwork produces poor Workmanship

Durability of concrete refers to its lifetime, and it depends to great extent on the mix strength and workmanship applied during production.

Apart from quality and workmanship, other factors that may affect durability of concrete are;

1) *Permeability:*

Porous concrete allows ingress of liquids and poses the reinforcements to corrosion or the aggregates to salt attack. Nevertheless, it may allow growth of vegetation; hence, causing cracks and stains on concrete.

2) *Wearing forces:*

Dynamic forces, like running water or mechanical abrasions wear down the concrete gradually. Fire also causes excessive expansion to concrete materials (e.g. reinforcement and aggregates), resulting in cracks and debonding.

3) *Weathering:*

Freezing and thawing create expansive pressure in the hardened concrete, resulting in cracks. However, this climatic phenomenon is not common in the tropical zone of east Africa.



Wearing of Bridge pier due to the effect of running water

Chapter 5

Soil Materials



Spreading Soil materials

Soil is unconsolidated top layer of land (ground), which consists of weathered rock fragments, organic matter, minerals, water and air in different proportions.

It is very important to know behaviour of soil as it is used largely for the construction of embankments and pavement layers, such as roadbed, fill, improved sub-grade, sub-base, base (and wearing course for gravel roads).

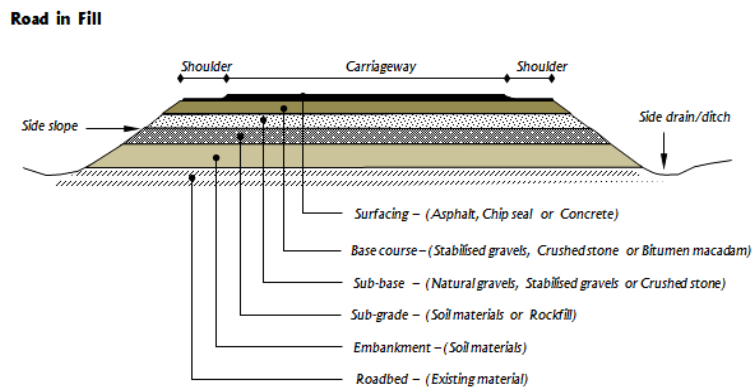

Figure 6: Typical cross-section of a road

Consistency of soil varies considerably with location and profile (depth) due to weathering process and transportation modes. Moreover, some functional properties such as grading, plasticity, permeability, compressibility and bearing capacity also vary with soil types.

Soil is very sensitive to moisture content than any other road construction material. Therefore, most of the road failures are more often subjective to its behaviour, which for the most part is affected by the *Atterberg limits* (liquid limit, plastic limit and plasticity index), *grading* (particle size distribution), *density* (compactness) and *strength* (bearing capacity).

Fundamental tests used to evaluate such engineering properties are as outlined below:



Dumping Gravel materials

5.1. Grading

Grading test (also known as *Sieve analysis* or *Particle size distribution*) determines the proportion of particle sizes in a granular material (e.g. aggregate, soil, etc.) The test is conducted in the same way as outlined for aggregates. However, since most of the soils are cohesive (the particles bind among themselves), wet sieving is more accurate method for determining the grading of soil than dry sieving.



Grading Sieves

Test procedure:

- 1) Break lumps in the dry soil with mallet (without crushing particles).
- 2) Mix the soil thoroughly and subdivide it to obtain test sample.
- 3) Determine the weight of test sample and record it (m_1).
- 4) Arrange sieves in sequence (order of their sizes).
- 5) Pass the sample on 20mm sieve and brush the larger particles to remove fines.
- 6) Sieve particles retained on 20mm sieve on the larger sieves (e.g. 75mm, 63mm, 50mm, 37.5mm and 28mm) and record the cumulative weight retained on each sieve (m_2).
- 7) Wash the particles passing 20mm sieve (a little at a time) on 1.18mm or 2.36mm sieve, nested on top of 0.075mm sieve.
- 8) Dry the washed material in oven to constant weight.
- 9) Then, sieve it on 14mm downward to 0.075mm sieve and record the cumulative weight retained on each sieve (also as m_2).

Note:

Since, the smallest size of sieves (used in laboratory) is 0.063mm, grading of particles smaller than 0.063mm is normally determined by *Sedimentation method* (known also as *Hydrometer method*), which uses a dispersant solution and hydrometer to measure particle sizes in a soil suspension (colloid) by correlating the decreasing density of suspension and settling time intervals.

Dispersant: – is made up of 33g of Sodium Hexametaphosphate, 7g of Sodium Carbonate and distilled water to make 1 liter of solution.

Dispersion: – means separation of disconnected particles into suspension.

Grading by sedimentation method is not common in roadworks, therefore, is not outlined in this Guide. However, the useful formula for calculating the equivalent particle diameter has been provided for awareness of the reader.



Sieve Shaker

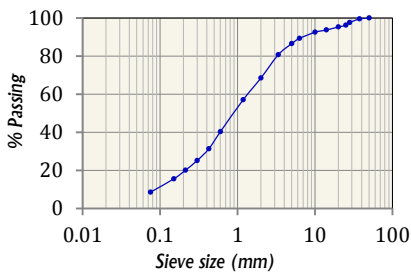

Grading Curve

Grading Calculations:

- Percentage retained on each sieve

$$\% \text{ retained} = \frac{m_2 \times 100}{m_1}$$

- Percentage passing on each sieve

$$\% \text{ passing} = 100 - \% \text{ retained}$$

- Grading modulus (GM):

$$\frac{300 - \% \text{ passing } 2\text{mm} - \% \text{ passing } 0.425\text{mm} - \% \text{ passing } 0.075\text{mm}}{100}$$

- Coefficient of uniformity (d_{60}/d_{10}):

$$C_u = \frac{d_{60} \text{ (sieve size at which 60\% of material passes)}}{d_{10} \text{ (sieve size at which 10\% of material passes)}}$$

- Coefficient of gradation:

$$C_k = (d_{30})^2 / (d_{60} \times d_{10})$$

- Equivalent particle diameter (Sedimentation method):

$$D = 0.005531 \sqrt{\eta H / (G_s - 1)t}$$

Where:

η = viscosity of water at test temperature
(20 °C = 1.0, 25 °C = 0.9 and 30 °C = 0.8)

H = effective depth of hydrometer.

G_s = specific gravity of soil.

t = elapsed time

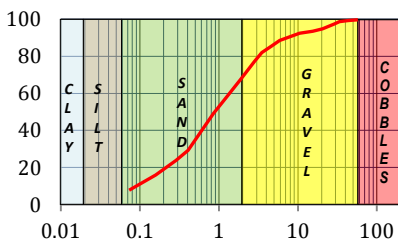

Particle Classification

The percentages passing through the sieves are normally plotted on a graph as *y-axis* and sieve sizes as *x-axis* (in a log-scale) to produce the *grading curve*, which is used to classify soil materials in accordance to its particle sizes:

- Clay (particles smaller than 0.02mm)
- Silt (particles ranging 0.02mm – 0.6mm)
- Sand (particles ranging 0.6mm – 2mm)
- Gravel (particles ranging 2mm – 60mm)
- Cobbles (particles ranging 60mm – 200mm)
- Boulders (particles larger than 200mm)

Example:

Project	TAIFA AVENUE	Checked By: Date:
Location	KM 1+500	
Material	NATURAL GRAVEL	Approved By: Date:
Tested by	KISUNGE	
Date	JAN. 2003	
Ref:	BS 1377: Part 2	

TOTAL WEIGHT OF SAMPLE (g)		2123.4		REMARKS
Sieve (mm)	Wt retained (g)	% Retained	% Passing	
50.0	0	0.0	100.0	
37.5	0	0.0	100.0	
28	29.2	1.4	98.6	
20	80.1	3.8	96.2	
14	133.4	6.3	93.7	
10	158.6	7.5	92.5	
6.3	227.6	10.7	89.3	
5.0	285.9	13.5	86.5	
3.35	419.4	19.8	80.2	
2.00	649.5	30.6	69.4	
1.18	912.3	43.0	57.0	
0.600	1298.0	61.1	38.9	
0.425	1459.2	68.7	31.3	
0.300	1590.4	74.9	25.1	
0.212	1697.8	80.0	20.0	
0.150	1794.1	84.5	15.5	
0.075	1942.3	91.5	8.5	
Pan				

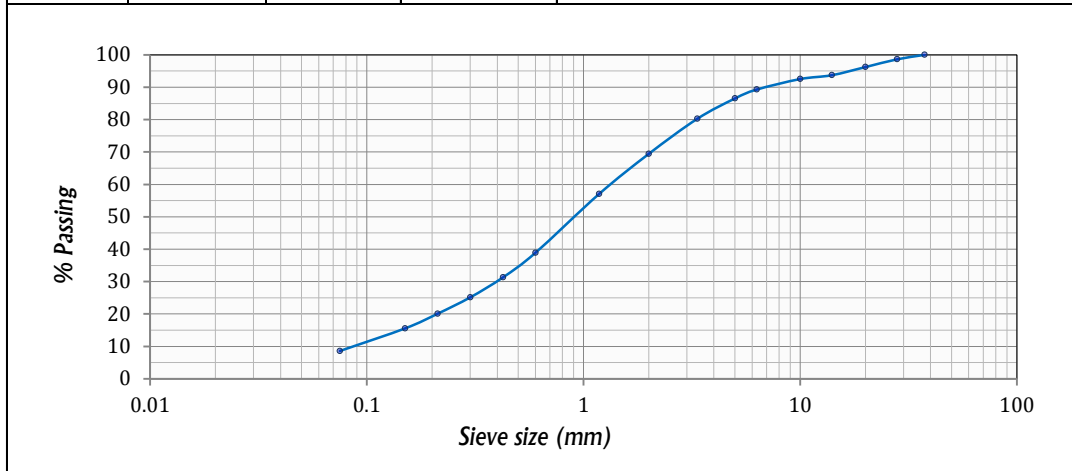

Calculations:

Percentage Retained :	$\frac{\text{Wt. Retained on the sieve} \times 100}{\text{Total weight of sample}}$	Example (sieve 14) $\frac{133.4 \times 100}{2123.4} = 6.3\%$
Percentage Passing :	$100 - \% \text{ Retained on the sieve}$	Example (sieve 14) $(100 - 6.3) = 93.7\%$
Grading Modulus (GM):	$\frac{300 - \% \text{pass } 2\text{mm} - \% \text{pass } 0.425\text{mm} - \% \text{pass } 0.075\text{mm}}{100}$	Example $\frac{300 - 69.4 - 31.3 - 8.5}{100} = 1.9$
Coefficient of Uniformity (C_u):	$\frac{d_{60} \text{ (sieve size at which 60\% of the material passes)}}{d_{10} \text{ (sieve size at which 10\% of the material passes)}}$	Example $\frac{1.4 \text{ mm}}{0.09 \text{ mm}} = 15.6$
Coefficient of Gradation (C_g):	$\frac{(d_{30})^2}{d_{60} d_{10}}$	Example $\frac{(0.4)^2}{1.4 \times 0.09} = 1.3$

5.2. Atterberg limits

Atterberg limits are simply referred to as plasticity property, since; the outward sign of the limits is *plasticity index*, which reflects the sticking property of soil (linked with clay content). However, the *Atterberg limits* determine general consistency of soil (i.e. the range of water contents, at which the soil changes from *solid* to *plastic* and from *plastic* to *liquid* states). The limits were established by a Swedish chemist known as Albert Atterberg, hence, taking the name *Atterberg*.

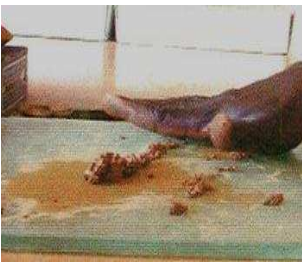

Plastic Limit test

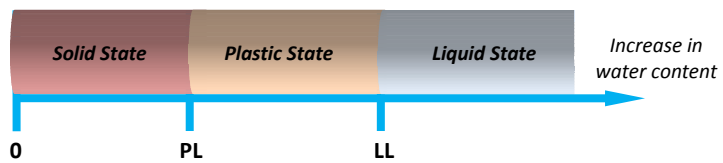

a) Plastic limit (PL)

Plastic limit is the minimum moisture content that changes a soil from *solid* (dry state) to a *plastic* (mouldable) state. It is determined in the laboratory as the moisture content, which allows a soil sample to be moulded into a loop that cracks when its diameter is about 3mm.

Test procedure:

- 1) Sieve the air-dried soil on 0.425mm sieve to obtain about 300g, and take about 20g of the material for the test (reserve the remaining amount of sieved soil for *liquid limit* test).
- 2) Place the sample (20g) on a glass plate and mix it thoroughly with distilled water using spatula (soaking for 24 hrs is required for clayey soils).
- 3) Mould a ball between the fingers, and then roll it between the palms of the hands until slight cracks appear on the surface.
- 4) Form a thread of about 6mm between the first finger and the thumb.
- 5) Roll the thread between tips of the fingers and the glass plate until it cracks (ensure the cracks appear when the thread is about 3mm)
- 6) Collect broken pieces of the thread into two containers, and determine the moisture content.
- 7) Report the average moisture content (in whole number) as the *Plastic limit*.



Liquid Limit test



Casagrande Apparatus

b) Liquid limit (LL)

Liquid limit is the moisture content that changes soil from *plastic* state to a *liquid* state. It is determined in the laboratory as the moisture content that makes a soil groove close with 25 blows of the Casagrande apparatus; or the moisture content that allows a cone to penetrate 20mm in a soil sample in 5 seconds.

Casagrande method:

- 1) Take about 200g of material passing through 0.425mm sieve.
- 2) Place sample on the glass plate and mix it thoroughly with distilled water using spatula (soaking for 24 hrs is required for clayey soils).
- 3) Place a portion of the mixed sample in Casagrande apparatus and level it parallel with the base of apparatus.
- 4) Cut a groove along the diameter through the center of the hinge.
- 5) Turn the handle at a rate of 2 revolutions per second until the two sides of the groove come into contact (along a length of 13mm) and record the number of blows that closed the groove.
- 6) Take a small portion of the material for moisture content.
- 7) Remove the soil from apparatus, add little water, mix thoroughly and repeat step 3) to 6) at least four times.
- 8) Plot the moisture content on *y-axis* and number of blows on *x-axis* on a semi-logarithmic chart and join the points by a straight line (best-fit line).
- 9) Interpolate the moisture content corresponding with 25 blows and report it as the *Liquid limit*.

Penetrometer method:

- 1) Sieve air-dried soil on 0.425mm sieve and take about 200g of the material passing the sieve.
- 2) Place sample on a glass plate and mix it thoroughly with distilled water using spatula (soaking for 24 hrs is required for clayey soils).
- 3) Place a portion of the mixed sample in the soil cup and level it off with the edge of the cup.
- 4) Place the cup under cone and lower the cone until it just touches the surface of the soil; then record the dial gauge reading.
- 5) Release the cone for 5 seconds and then lock it in position.
- 6) Lower dial gauge to touch the cone and record the reading.
- 7) Lift the cone up, remove some soil from the cup and add more soil from the mixing glass.
- 8) Place the cup under the cone, penetrate it again (repeat this step three times) and record the average of the three readings.



Cone Penetrometer



Linear Shrinkage Mould

- 9) Take a small portion of the material from the cup for moisture content.
- 10) Lift the cone up, remove the soil, add little water, mix thoroughly and repeat step 3) to 8) at least four times by adding little water in the same sample.
- 11) Plot cone penetration on *y-axis* and moisture content on *x-axis* on a linear scale and join the points by straight line.
- 12) Interpolate the moisture content corresponding with the penetration of 20mm and report it as the *Liquid limit*.

c) Plasticity Index (PI)

Plasticity index is the range of moisture contents at which soils remain plastic (mouldable condition). It is determined arithmetically as the difference of *Liquid limit* and *Plastic limit* (i.e. $PI = LL - PL$).

Calculations:

- Plasticity Index (PI) = $LL - PL$
- Plasticity Modulus (PM) = $PI \times \% \text{ passing } 0.425\text{mm sieve}$
- Plasticity Product (PP) = $PI \times \% \text{ passing } 0.075\text{mm sieve}$
- Liquidity Index (LI) = $(w - PL) / (LL - PL)$

Where: *w* is the natural moisture content.

d) Linear Shrinkage

Linear shrinkage:- the decrease in length of a wet soil after drying. It simulates the volumetric changes that occur as wet soil dries.

Test procedure:

- 1) Clean the mould, measure the length (*h1*) and apply a thin film of grease at the inside walls.
- 2) Take about 150g of the soil paste at Liquid limit, fill it fully in the mould and tap it on a hard surface to remove air pockets.
- 3) Level the mould and remove surplus soil around it.
- 4) Allow specimen to dry in air for 24 hours, and then dry it in oven.
- 5) Allow specimen to cool and measure its length (*h2*).

$$\text{Linear Shrinkage (LS)} = \frac{\text{Initial length (h1)} - \text{Dry length (h2)} \times 100}{\text{Initial length (h1)}}$$



A Digital Balance

Example:

Project	TAIFA AVENUE	Checked By:	
Location	KM I+500		Date:
Material	NATURAL GRAVEL	Approved By:	
Tested by	KISUNGE		Date:
Date	JAN. 2003		
Ref.	BS 1377, Part 2.		

Method A: PENETROMETER									
LIQUID LIMIT					PLASTIC LIMIT				
Cone Penetration (mm)	17	19	24	26	Container No.	P1	P6		
Container No.	T6	T4	T2	T5	wt. Cont + wet soil (g)	19.40	20.13		
wt. Cont + wet soil (g)	31.84	33.79	34.69	32.81	wt. Cont + dry soil (g)	18.17	18.82		
wt. Cont + dry soil (g)	29.69	31.20	31.70	30.34	wt. of moisture (g)	1.23	1.31		
wt. of moisture (g)	2.15	2.59	2.99	2.47	wt. of container (g)	10.63	10.67		
wt. of container (g)	19.81	20.71	21.11	22.51	wt. of dry soil (g)	7.54	8.15	Ave.	
wt. of dry soil (g)	9.88	10.49	10.59	7.83	Moisture content (%)	16.3	16.1	16	
Moisture content (%)	21.76	24.69	28.23	31.55					

Penetration (mm)								
	Moisture content (%)	20	22	24	26	28	30	32

Sample preparation:									
a: As received	_____								
b: Air dried at _____ °C	_____								
c: Oven dried _____ °C	_____								
d: washed on (0.425mm)	_____								
e: Not known	_____								
% Retained on 0.425mm	_____								

Method B: CASAGRANDE									
LIQUID LIMIT					PLASTIC LIMIT				
Number of blows	30	26	20	15	Container No.	Y3	Y4		
Container No.	M1	M6	M3	M2	wt. Cont + wet soil (g)	15.54	15.22		
wt. Cont + wet soil (g)	33.02	34.01	32.35	35.68	wt. Cont + dry soil (g)	14.79	14.54		
wt. Cont + dry soil (g)	30.30	31.17	29.87	32.64	wt. of moisture (g)	0.75	0.68		
wt. of moisture (g)	2.72	2.84	2.48	3.04	wt. of container (g)	10.65	10.81		
wt. of container (g)	19.77	20.68	21.07	22.49	wt. of dry soil (g)	4.14	3.73	Ave.	
wt. of dry soil (g)	10.53	10.49	8.80	10.15	Moisture content (%)	18.1	18.2	18	
Moisture content (%)	25.8	27.1	28.2	30.0					

Moisture content (%)					
	Number of blows	10	20	30	40

Sample preparation:									
a: As received	_____								
b: Air dried at _____ °C	_____								
c: Oven dried _____ °C	_____								
d: washed on (0.425mm)	_____								
e: Not known	_____								
% Retained on 0.425mm	_____								

Calculations:			
Method A	CASAGRANDE	Liquid Limit (LL)	25
		Plastic Limit (PL)	16
		Plasticity Index (PI)	9
Method B	PENETROMETER	Liquid Limit (LL)	26
		Plastic Limit (PL)	18
		Plasticity Index (PI)	8
	LINEAR SHRINKAGE (LS)	Initial Length of Specimen (wet)	140
		Final Length of Specimen (dry)	135
		LS = (Initial length - final length) x 100 / Initial length	3.6
	PLASTICITY MODULUS (PM)	PI x % Passing 0.425 mm	
	SHRINKAGE PRODUCT (SP)	LS x % Passing 0.425 mm	

5.3. Proctor

Proctor is a compaction method, used in the laboratory to show the relationship of *moisture content* and *density* of a material (compacted mass of material in a unit volume through a range of moisture contents). It was named after R. Proctor who developed the relationship. The applicable terms in the test include;

Density: - Concentration of particles per unit volume.

Moisture Content: - Amount of water, expressed as percentage of the dry mass of material.

Maximum Dry Density (MDD): - The greatest dry mass of soil (or graded aggregates) achieved by compacting the soil (or graded aggregate) material in a unit volume through a range of moisture contents.

Optimum Moisture Content (OMC): - accurate amount of water that facilitates compaction to the maximum dry density.



Light Compaction equipment

British Standards (BS):

- a) Mould size: - 105 mm dia. x 115.5 mm high (volume = 1000 cm³)
 - Light Compaction (2.5kg rammer) – 3 layers, 27 blows per layer.
 - Heavy Compaction (4.5kg rammer) – 5 layers, 27 blows per layer.
- b) Mould size: - 152 mm dia. x 127 mm high (volume = 2305 cm³)
 - Light Compaction (2.5kg rammer) – 3 layers, 62 blows per layer.
 - Heavy Compaction (4.5kg rammer) – 5 layers, 62 blows per layer.
 - Vibrating Hammer (for aggregates) – 3 layers, 1 minute per layer.

American Standards (AASHTO):

- a) Mould size: - 101.6 mm dia. x 116.4 mm high (volume = 950 cm³)
 - T99 (2.5kg rammer) – 3 layers, 25 blows per layer.
 - T180 (4.5kg rammer) – 5 layers, 25 blows per layer.
- b) Mould size: - 152.4 mm dia. x 116.4 mm high (volume = 2124 cm³)
 - T99 (2.5kg rammer) – 3 layers/56 blows per layer.
 - T180 (4.5kg rammer) – 5 layers/56 blows per layer.



Heavy Compaction equipment

Note:

British Standards (BS) and American Standards (AASHTO) utilize different sizes of moulds and different effort, therefore, may give incomparable figures for the same sample.



Proctor Test

General procedure:

- 1) Obtain about 6kg of air-dried soil passing 20mm sieve.
- 2) Weigh the mould with its base plate and record its mass ($m1$).
- 3) Put the soil in a tray and mix it thoroughly with water (you may start with 120ml of water and keep adding the same amount).
- 4) Place the mould on a concrete base and fix the collar.
- 5) Compact the soil in accordance with the specified method (e.g. BS, AASHTO, CML, etc.) using proper mould and rammer.
- 6) Distribute the blows uniformly over the surface of each layer (the last layer should not be more than 6mm over the mould).
- 7) After the last layer, remove the collar, trim the excess soil over the mould and weigh it with its base plate and soil ($m2$).
- 8) Place the mould in a tray, remove the soil and take a small portion for moisture content (put little soil in a tin, record the weight and dry it in oven; then take its weight again after drying).
- 9) Break the specimen, mix it with the remainder material in the tray, add more water (120ml again) and mix it thoroughly.
- 10) Repeat step 5) to 8) at least four times (with increment of 120ml for gravelly soil or 180ml for clayey soil).

Calculations:

- Moisture content (w) =
$$\frac{(\text{mass of wet soil} - \text{mass of dry soil}) \times 100}{\text{mass of dry soil}}$$
- Bulk density (ρ) =
$$\frac{m2 - m1}{\text{volume of mould}}$$
- Dry density (ρ_d) =
$$\frac{\rho \times 100}{w + 100}$$
- Air voids line is calculated as follows:

$$\rho_d = \frac{\rho_w (1 - 0.01V_a)}{(1/G_s) + (w/100)}$$

Where:

- ρ_d = dry density of soil
- ρ_w = density of water (preferable: 0.98 or 1.0)
- V_a = % of air voids (preferable: 0%, 5% and 10%)
- G_s = specific gravity of the soil
- w = moisture content of the soil.



Vibrating hammer

Example:

PROJECT	TAIFA AVENUE	CHECKED BY:
LOCATION	KM. 1+500	DATE:
LAYER	SUB-BASE	APPROVED BY:
MATERIAL	NATURAL GRAVEL	DATE:
TECHNICIAN	KISUNGE	
DATE	JAN. 2003	
REF.		

Bulk density determination (2.5kg / 4.5kg Rammer)			AASHTO T180					
TEST NO			1	2	3	4	5	6
A	Weight of Sample	g	6000	6000	6000	6000	6000	
B	Water added	ml	120	240	360	480	600	
C	Weight of mould + Sample	g	8610	8982	9298	9256	9011	
D	Weight of mould	g	4475	4475	4475	4475	4475	
E	Weight of Sample (C - D)	g	4135	4507	4823	4781	4536	
F	Volume of mould	cm ³	2124	2124	2124	2124	2124	
G	WET DENSITY (E / F)x1000	Kg/m ³	1947	2122	2271	2251	2136	

Bulk density determination (Vibrating hammer)			BS: Vibrating hammer					
A	Weight of Sample	g	8000	8000	8000	8000	8000	
B	Water added	ml	120	240	360	480	600	
C	Weight of mould + Sample	g	14349	14896	15125	15218	15003	
D	Weight of mould	g	9309	9309	9309	9309	9309	
E	Weight of Sample (C - D)	g	5040	5587	5816	5909	5694	
F	Height of Specimen (h)	mm	127	133	133	133	127	
G	WET DENSITY = $\frac{E \times 1000}{18.15 \times h}$	Kg/m ³	2187	2314	2409	2448	2470	

Moisture content determination							
	CONTAINER NO.		A15	A11	A9	A14	A3
H	Weight of Wet soil + Container	g	256.21	280.07	247.26	259.30	240.07
I	Weight of Dry soil + Container	g	250.63	270.51	236.32	244.87	224.24
J	Weight of Water (H - I)	g	5.58	9.56	10.94	14.43	15.83
K	Weight of empty Container	g	86.43	86.61	86.52	85.27	85.34
L	Weight of Dry Soil (I - K)	g	164.20	183.90	149.80	159.60	138.90
M	Moisture Content (J x 100) / L	%	3.4	5.2	7.3	9.0	11.4
N	DRY DENSITY (Gx100) / (M + 100)	Kg/m ³	1883	2017	2116	2064	1917

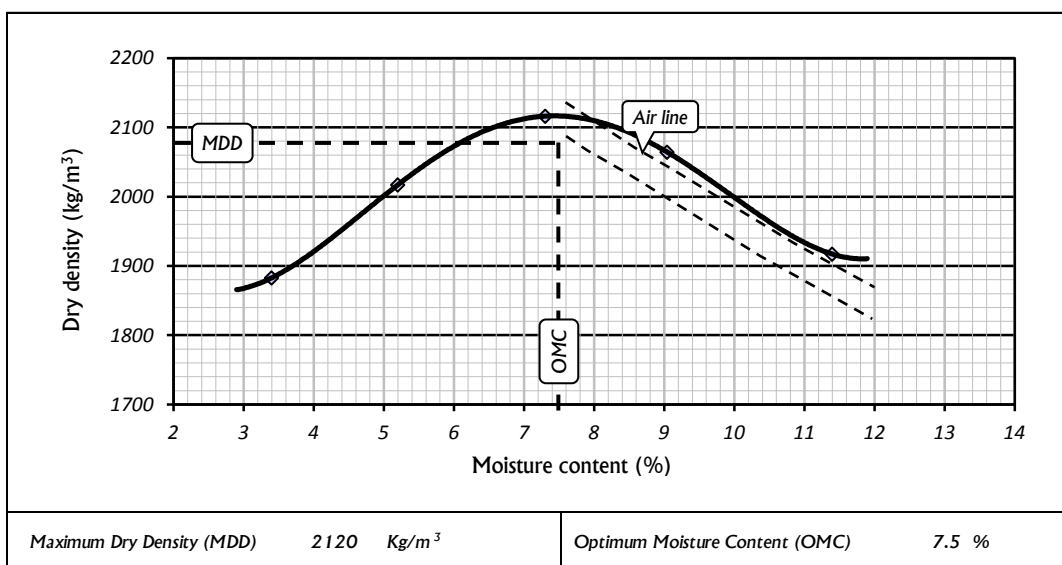

5.4. CBR

CBR letters abbreviate the name *California Bearing Ratio* (the basic test used to measure strength of subgrade soil and pavement layers). The test is conducted by penetrating a moulded soil specimen with a cylindrical plunger at a constant rate of 1mm per minute; and the forces corresponding with penetration of 2.5mm and 5.0mm are computed and compared with the strength of California rocks (tested in California, USA).

However the CBR test development was based on the empirical observations, which does not simulate fundamental properties that have great influence on the soil performance (e.g. elastic stiffness and resilient modulus), it is still the popular method of evaluating strength of subgrade soil and pavement materials in many countries. The common terms found in the test are:

Plunger: - cylindrical piston (of 1935mm², fixed to the proving ring of CBR machine) that penetrates the soil specimen.

Dial gauge: - the instrument, which indicates the load reading or penetration of plunger as the testing continues.

Surcharge: - metal disc placed over soil specimen during soaking and testing to simulate weight of pavement layers.

Swell: - bulging or expansion of soil caused by water absorption.

Test methods:

a) British Standards (BS) Method:

Mould size: 152 mm dia. x 127 mm high (volume = 2305 cm³).

Specimen 1: 2.5kg rammer, 3 layers, 62 blows per layer,

Specimen 2: 4.5kg rammer, 5 layers, 30 blows per layer,

Specimen 3: 4.5kg rammer, 5 layers, 62 blows per layer.

Static Compaction: 1 specimen, 3 layers, 1 minute per layer.

b) American Standards (AASHTO) Methods:

Mould size: 152.4 mm dia. x 116.4 mm high (volume = 2124 cm³).

• Using 2.5kg Rammer:

Specimen 1: 3 layers, 10 blows per layer,

Specimen 2: 3 layers, 30 blows per layer,

Specimen 3: 3 layers, 65 blows per layer.

• Using 4.5kg Rammer:

Specimen 1: 5 layers, 10 blows per layer,

Specimen 2: 5 layers, 30 blows per layer,

Specimen 3: 5 layers, 65 blows per layer.



CBR Equipment



Compaction equipment



Auto-compactor

General procedure:

a) CBR Compaction (dynamic):

- 1) Carry out *Proctor test* in order to get the maximum dry density (*MDD*) and the optimum moisture content (*OMC*) of the soil.
- 2) Prepare about 6kg of air-dried soil passing 20mm sieve for each of the CBR specimen (normally a set of three specimens is made).
- 3) Determine the natural moisture content (*NMC*) of the dry soil before adding water.
- 4) Calculate the amount of water to be added to the soil to get the optimum moisture content (*OMC*) as follows:

$$\text{Water to be added } (w) = \frac{(OMC - NMC) \times m}{(NMC + 100)}$$

Where:

OMC = optimum moisture content obtained previously in the Proctor test.

NMC = natural moisture content of the sample (dry soils normally contain slight moisture contents, which are not easily recognizable).

m = weight of dry sample (e.g. 6kg).

- 5) Weigh the mould with its perforated base plate and record its mass (*m1*).
- 6) Put the soil in a tray and add amount of water calculated in step 4.
- 7) Mix the sample thoroughly and take a small portion for moisture content.
- 8) Place the mould on a hard surface and fix the collar.
- 9) Place the layers according to the specified method (e.g. BS, AASHTO, etc.) and compact each layer using proper rammer.
- 10) Distribute blows uniformly over the surface of each layer (the last layer should not project over the mould by more than 6mm).
- 11) Remove collar, trim excess soil over the mould and take the weight of the mould with the base plate and soil (*m2*).
- 12) Remove base plate and put filter paper on it; invert the specimen (top to be on the plate) and tie the base plates back on the moulds
- 13) Put perforated swell plate on the specimen, add surcharge weights (of about 4.5kg) and put the specimen in a curing tank (use thin wooden strips to elevate the mould from base of the tank).
- 14) Place swell gauge on the specimen; record the initial reading (*R1*) then, add water to approximately 5mm below the top of the collar and leave the specimen in water for 4 days.



CBR Penetration

Calculations:

- Moisture content (w) = $\frac{\text{Mass of water} \times 100}{\text{Mass of dry soil}}$
- Bulk density (ρ) = $\frac{m_2 - m_1}{\text{Volume of mould}}$
- Dry density (ρ_d) = $\frac{\rho \times 100}{w + 100}$

b) CBR Penetration:

- 1) After 4 days, place swell gauge on each specimen and record the final readings (R_2).
- 2) Remove the specimens from water, allow them to drain for 15 minutes and then penetrate each one.
- 3) Record the dial gauge reading at each penetration interval (as shown in the test sheet)
- 4) Use the ring factor to convert the gauge readings into force (KN).

Calculations:

- CBR value at 2.5mm: = $\frac{\text{Force at 2.5mm} \times 100}{13.2 \text{ (KN)}}$
- CBR value at 5.0mm: = $\frac{\text{Force at 5.0mm} \times 100}{20.0 \text{ (KN)}}$
- Swell: = $\frac{((\text{Initial reading } (R_1) - \text{Final reading } (R_2)) \times 100}{\text{Height of specimen}}$

c) CBR Results:

- Record the value obtained at penetration of **2.5mm** and **5.0mm**; and report the higher value as the CBR of the material
(Note that, the British Standards specify CBR value at 2.5mm and require the test to be re-run if the value at 5.0mm is greater than the one at 2.5mm).
- Report the swell value obtained at heavy compaction (i.e. swell obtained at the mould compacted with highest number of blows using 4.5kg rammer).

Example:

PROJECT	TAIFA AVENUE	CHECKED BY:
LOCATION	KM. 1 + 500	
LAYER	SUB-BASE	DATE:
MATERIAL	NATURAL GRAVEL	APPROVED BY:
TECHNICIAN	KISUNGE	
DATE	JAN. 2003	DATE:

CBR PREPARATION SHEET - BS 1377: Part 4

Bulk density			
Compaction effort		2.5 kg Rammer	4.5 kg Rammer
Number of Blows per each Layer		62 blows / layer : 3 layers	30 blows / layer : 5 layers
Mould NO.		24	4
Weight of mould + Base plate + Soil (m1)	(g)	13558	13877
Weight of mould + Base plate (m2)	(g)	8974	8947
Weight of Soil (m1 - m2)	(g)	4584	4930
Volume of Mould (V)	cm ³	2305	2305
BULK DENSITY (m1 - m2)/V	g/cm ³	1.989	2.139
Moisture content			
TIN No.		A36	A10
Weight of Wet soil + Container (w1)	g	272.03	266.10
Weight of Dry soil + Container (w2)	g	258.98	253.18
Weight of Water (w1 - w2)	g	13.05	12.92
Weight of empty Container (c)	g	85.45	86.01
Weight of Dry Soil (w2 - c)	g	173.53	167.17
Moisture Content (w1-w2)x100/(w2-c)	%	7.5	7.7
DRY DENSITY (Bulk dens. x 100)/(mc + 100)	g/cm ³	1.850	1.985
Soaking record			
Date of moulding		20/01/2003	20/01/2003
Soaking days		4	4
Date of penetration		24/01/2003	24/01/2003
Swell value			
Initial gauge reading (R1)	(mm)	10.63	11.95
Final gauge reading (R2)	(mm)	10.68	11.99
SWELL (R2-R1)x100/127*	%	0.04	0.03

*Height of specimen in mm: = 127mm for BS moulds or 116.4mm for AASHTO moulds

PROJECT	TAIFA AVENUE	CHECKED BY:
LOCATION	KM. 1+500	DATE:
LAYER	SUB-BASE	APPROVED BY:
MATERIAL	NATURAL GRAVEL	DATE:
TECHNICIAN	KISUNGE	
DATE	JAN. 2003	

CBR PENETRATION SHEET - BS 1377: Part 4

Ring factor: 0.02263 KN/division			Rate of penetration: 1.27 mm/min.					
62 Blows / 3 layers / 2.5kg rammer			30 Blows / 5 layers / 4.5kg rammer			62 Blows / 5 layers / 4.5kg rammer		
Penetration of plunger (mm)	Dial Gauge Reading (div)	Force on plunger (kN)	Penetration of plunger (mm)	Dial Gauge Reading (div)	Force on plunger (kN)	Penetration of plunger (mm)	Dial Gauge Reading (div)	Force on plunger (kN)
0.00	0	0.00	0.00	0	0.00	0.00	0	0.00
0.25	11	0.25	0.25	47	1.06	0.25	63	1.43
0.50	29	0.66	0.50	102	2.31	0.50	137	3.10
0.75	41	0.93	0.75	146	3.30	0.75	180	4.07
1.00	50	1.13	1.00	177	4.01	1.00	224	5.07
1.25	61	1.38	1.25	200	4.53	1.25	257	5.82
1.50	75	1.70	1.50	233	5.27	1.50	289	6.54
1.75	98	2.22	1.75	245	5.54	1.75	324	7.33
2.00	110	2.49	2.00	270	6.11	2.00	348	7.88
2.25	125	2.83	2.25	283	6.40	2.25	371	8.40
2.50	130	2.94	2.50	300	6.79	2.50	390	8.83
2.75	135	3.06	2.75	310	7.02	2.75	412	9.32
3.00	139	3.15	3.00	321	7.26	3.00	432	9.78
3.25	145	3.28	3.25	334	7.56	3.25	460	10.41
3.50	150	3.39	3.50	345	7.81	3.50	480	10.86
3.75	157	3.55	3.75	350	7.92	3.75	500	11.32
4.00	165	3.73	4.00	365	8.26	4.00	522	11.81
4.25	180	4.07	4.25	374	8.46	4.25	534	12.08
4.50	187	4.23	4.50	387	8.76	4.50	547	12.38
4.75	196	4.44	4.75	400	9.05	4.75	563	12.74
5.00	210	4.75	5.00	420	9.50	5.00	580	13.13
5.25	222	5.02	5.25	440	9.96	5.25	598	13.53
5.50	237	5.36	5.50	456	10.32	5.50	621	14.05
5.75	252	5.70	5.75	470	10.64	5.75	640	14.48
6.00	270	6.11	6.00	483	10.93	6.00	661	14.96
6.25	288	6.52	6.25	499	11.29	6.25	680	15.39
6.50	296	6.70	6.50	520	11.77	6.50	699	15.82
6.75	310	7.02	6.75	544	12.31	6.75	719	16.27
7.00	340	7.69	7.00	562	12.72	7.00	738	16.70
7.25	355	8.03	7.25	581	13.15	7.25	753	17.04
7.50	370	8.37	7.50	602	13.62	7.50	770	17.43

CBR GRAPHS - BS 1377: Part 4

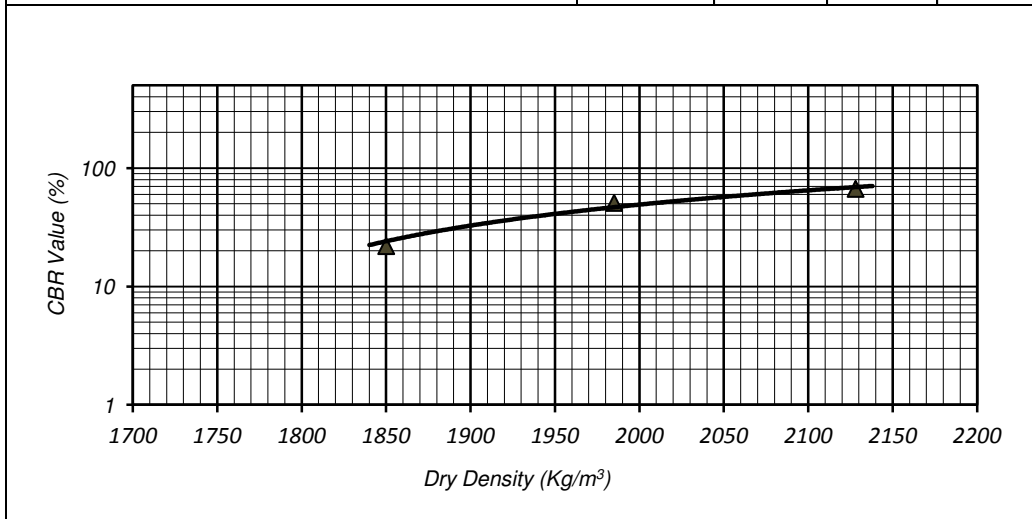
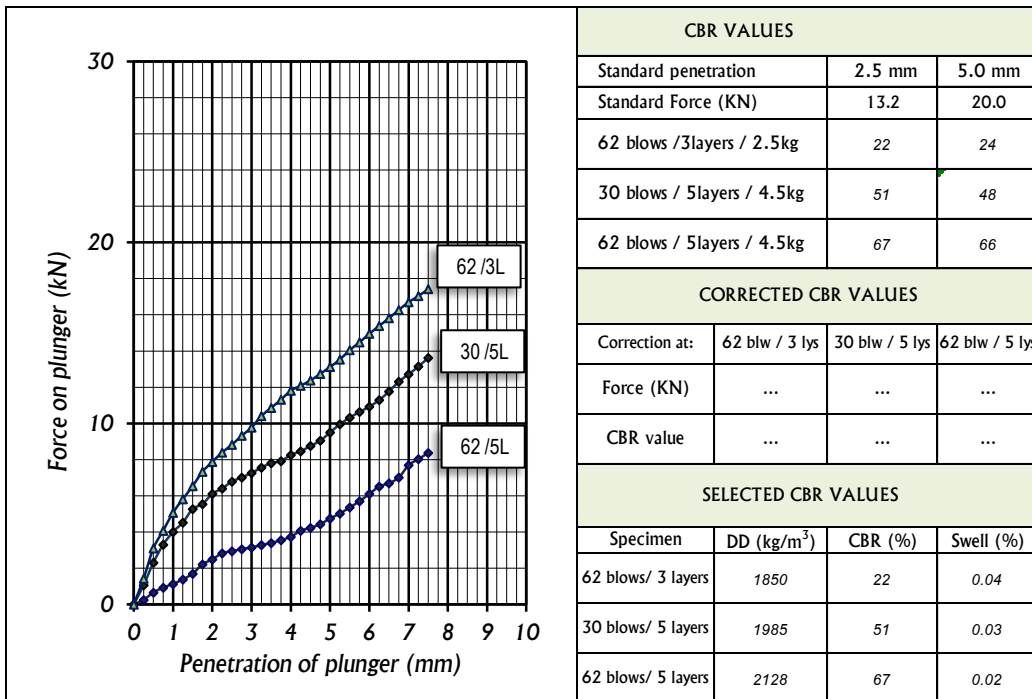

TEST SUMMARY			
Compaction Degrees	Dry Density (kg/m ³)	CBR Value (%)	Swell %
100 % MDD (kg/m ³)	2120	65	0.02
97 % MDD (kg/m ³)	2056	60	
95 % MDD (kg/m ³)	2014	50	
93 % MDD (kg/m ³)	1971	45	
90 % MDD (kg/m ³)	1908	35	

ENGINEER'S COMMENTS

PROJECT	TAIFA AVENUE	CHECKED BY:
LOCATION	KM. 1 + 500	
LAYER	SUB-BASE	DATE:
MATERIAL	NATURAL GRAVEL	APPROVED BY:
TECHNICIAN	KISUNGE	
DATE	JAN. 2003	DATE:

CBR PENETRATION SHEET - AASHTO T193

Ring factor:	0.02263 KN/division	Rate of penetration:	1.27 mm/min.
--------------	---------------------	----------------------	--------------

10 BLOWS			30 BLOWS			65 BLOWS		
Penetration of plunger (mm)	Dial Gauge Reading (div.)	Force on plunger (kN)	Penetration of plunger (mm)	Dial Gauge Reading (div.)	Force on plunger (kN)	Penetration of plunger (mm)	Dial Gauge Reading (div.)	Force on plunger (kN)
0.00	0	0.00	0.00	0	0.00	0	0	0
0.64	53	1.20	0.64	86	1.95	0.64	116	2.63
1.27	87	1.97	1.27	143	3.24	1.27	202	4.57
1.91	110	2.49	1.91	201	4.55	1.91	278	6.29
2.54	135	3.06	2.54	245	5.54	2.54	340	7.69
5.08	220	4.98	5.08	350	7.92	5.08	502	11.36
7.62	287	6.49	7.62	428	9.69	7.62	612	13.85

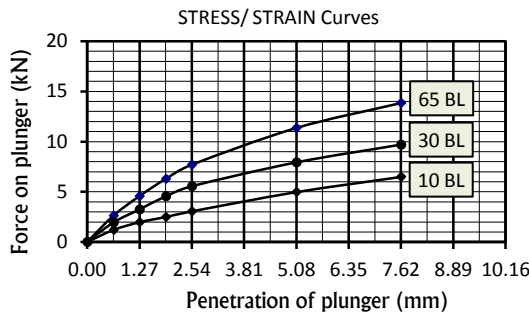

CBR VALUES		
Standard Penetration	2.54 mm	5.08 mm
Standard force (KN)	13.35	19.93
10 blows	23	25
30 blows	42	40
65 blows	58	57

SUMMARY			
Blows	DD (kg/m ³)	CBR %	Swell %
10	1715	25	0.30
30	1835	42	0.20
65	1922	58	0.10

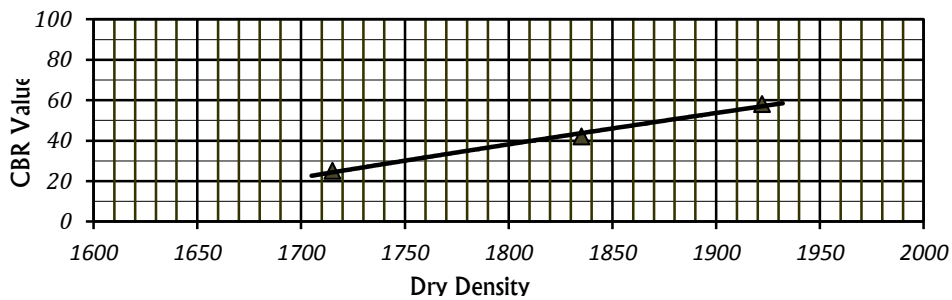

TEST SUMMARY

Compaction Degrees	Dry Density (kg/m ³)	CBR Value (%)	Swell %
100 % MDD (kg/m ³)	1915	56	0.1
97 % MDD (kg/m ³)	1858	47	
95 % MDD (kg/m ³)	1819	40	
93 % MDD (kg/m ³)	1781	35	
90 % MDD (kg/m ³)	1724	27	

ENGINEER'S COMMENTS

5.5. Field density

Field density test measures the degree of compaction on a layer by comparing the density achieved on the field by the maximum density obtained in the laboratory. The test is normally conducted by one of the methods;



Core Cutter



Balloon Apparatus



Nuclear Apparatus



Sand Apparatus

Core cutter: - the method is less accurate and is not recommended, unless urgent result is required and the soil is fine and soft enough for the cutter to penetrate without disturbing the specimen.

Balloon method: - the method utilizes a balloon and liquid (in a metal and glass apparatus) to measure the volume of a hole. The apparatus is a bit delicate, therefore, is not widely used.

Nuclear method: - is the modern and quickest method that applies the radioactive rays to measure density and water content of a pavement layer. However the nuclear apparatus is giving instant results, its effect on human health and suspicion on its accuracy make some Agencies deny its use on their projects.

Sand replacement method: - utilizes clean sand (passing 0.600mm and retaining on 0.300mm sieves) to measure the volume of hole in a road layer. The bulk density of sand is measured and used with the mass of sand that has filled the hole to calculate the volume of the hole (by dividing the *mass* by *density*).

Therefore, it is the most applicable and accurate method for testing the density of road layers.

Test procedure:

a) Sand in Cone (excess sand that repose over the hole):

- 1) Fill the apparatus with sand to constant mass (e.g. 8kg, 16kg, etc.), depending on its capacity.
 - 2) Place the apparatus in a tray, open the shutter and allow a volume of sand equivalent to that of the excavated hole to run out then close the shutter.
 - 3) Put base plate on a flat surface (e.g. glass plate) and place the apparatus on it, open the shutter and allow the sand to run out freely without any vibration.
 - 4) When there is no further run-out, close the shutter, collect the sand that has filled the cone and weight it.
 - 5) Repeat step 1) to 4) at least three times and take the average value as the weight of sand in cone (m_a).
-



Sand Calibration Apparatus

b) Sand Calibration (determination of bulk density):

- 1) Measure the volume of the calibration container (V_c).
- 2) Fill the apparatus with the sand to constant mass, e.g. 8kg or 16kg and record the weight (m_b).
- 3) Fix cone to the sand apparatus, close shutter and place it over the calibration container.
- 4) Open the shutter and allow the sand to run out freely.
- 5) When no further run-out, close the shutter and weigh the sand remaining in the bottle. Repeat step 2) to 5) at least three times and record the average weight (m_c).
- 6) Calculate the bulk density of sand as follows:

- Mass of sand to fill the container (M_s) = $m_b - m_a - m_c$
- Bulk density of sand (ρ_s): = $\frac{\text{Mass of sand } (M_s)}{\text{Volume of container } (V_c)}$

c) Field Density (determination of the field compaction):

- 1) Fill sand pouring apparatus with known mass of sand according to its capacity, e.g. 8kg or 16kg (m_1).
- 2) Level the place to be tested and brush away any loose material.
- 3) Place base plate in position and dig a round hole about 150mm deep for a 150mm layer or 200mm deep for a 200mm layer.
- 4) Collect all soil dug out of the hole, determine its weight (M_o) and take a small portion for moisture content (w).
(If moisture is to be determined later, then, put the soil in an airtight container or plastic bag).
- 5) Place the sand pouring apparatus over the hole (with the base plate) and allow the sand to run out freely without vibration.
- 6) When there is no further run-out, close shutter and weigh the sand remaining in the bottle (m_2).

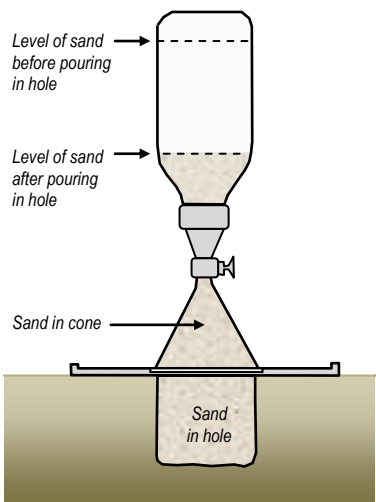

Determination of volume of hole

Calculations:

- Mass of sand in hole (M_h) = $m_1 - m_2 - m_a$
- Volume of hole (V_h) = $\frac{\text{Mass of Sand in hole } (M_h)}{\text{Bulk density of sand } (\rho_s)}$
- Bulk density of soil (ρ_o) = $\frac{\text{Mass of Soil from hole } (M_o)}{\text{Volume of hole } (V_h)}$
- Dry density of soil (ρ_d) = $\frac{100 \times \rho_o}{100 + w}$

Example:

PROJECT	TAIFA AVENUE	CHECKED BY:
LOCATION	KM. 1+500	
LAYER	SUB-BASE	DATE:
MATERIAL	NATURAL GRAVEL	APPROVED BY:
TECHNICIAN	KISUNGE	
DATE	JAN. 2003	

FIELD DENSITY TEST - BS 1377: Part 4

BULK DENSITY DETERMINATION												
TEST NO.		1	2	3	4	5	6	7	8	9	10	
	LOCATION (KM)	1+500	1+550	1+600	1+650	1+700	1+750	1+800	1+850	1+900	1+950	
	POSITION OF HOLE	RHS	C	LHS	C	RHS	C	LHS	C	RHS	C	
	DEPTH OF HOLE	15cm	15cm	15cm	15cm	15cm	15cm	15cm	15cm	15cm	15cm	
A	Weight of wet soil from Hole	g	6599	6285	6669	6182	6619	6239	5963	6422	6235	6387
B	Initial weight of Sand + Cylinder	g	8000	8000	8000	8000	8000	8000	8000	8000	8000	8000
C	Final weight of Sand + Cylinder	g	2585	2773	2580	2854	2562	2850	2995	2697	2780	2707
D	Weight of Sand in Cone and Plate	g	1410	1410	1410	1410	1410	1410	1410	1410	1410	1410
E	Weight of Sand in Hole (B - C - D)	g	4005	3817	4010	3736	4028	3740	3595	3893	3810	3883
F	Density of Sand (as calibrated)	g/cm ³	1.352	1.352	1.352	1.352	1.352	1.352	1.352	1.352	1.352	1.352
G	Volume of Hole (E / F)	cm ³	2962	2823	2966	2763	2979	2766	2659	2879	2818	2872
H	Bulk Density of Soil (A / G)	g/cm ³	2.228	2.226	2.249	2.237	2.222	2.255	2.243	2.230	2.213	2.224
MOISTURE CONTENT DETERMINATION												
I	Container No.		F1	F6	F2	F10	F7	F9	F5	F11	F15	F8
J	Weight of Container + Wet Soil	g	334.3	297.7	368.1	261.5	267.8	330.6	267.7	347.8	314.8	283.3
K	Weight of Container + Dry Soil	g	321.9	287.9	353.9	254.6	260.4	318.9	260.3	334.7	303.9	274.9
L	Weight of empty Container	g	160.0	160.0	160.0	160.0	160.0	160.0	160.0	160.0	160.0	160.0
M	Weight of Water (J - K)	g	12.4	9.8	14.2	6.9	7.4	11.7	7.4	13.1	10.9	8.4
N	Weight of Dry Soil (K - L)	g	161.9	127.9	193.9	94.6	100.4	158.9	100.3	174.7	143.9	114.9
P	Moisture Content (Mx100 / N)	%	7.7	7.7	7.3	7.3	7.4	7.4	7.4	7.5	7.6	7.3
DRY DENSITY DETERMINATION												
Q	Dry Density [Hx100/(P+ 100)]	g/cm ³	2.069	2.068	2.095	2.085	2.069	2.101	2.088	2.075	2.057	2.072
R	MDD (obtained in Proctor test)	g/cm ³	2.120	2.120	2.120	2.120	2.120	2.120	2.120	2.120	2.120	2.120
S	OMC (obtained in Proctor test)	%	7.5	7.5	7.5	7.5	7.5	7.5	7.5	7.5	7.5	7.5
T	Degree of Compaction (Qx100/R)	%	97.6	97.5	98.8	98.4	97.6	99.1	98.5	97.9	97.0	97.8
U	Minimum Requirement	%	95									

5.6. DCP Test

DCP letters abbreviate the name *Dynamic Cone Penetrometer*. A penetration test used for measuring the in-situ strength of a soil layer (either compacted or at a natural state). The test is normally carried out down to a depth of about 800mm below the starting level. [Note that; the effect of traffic loading is very marginal beyond 800mm of the road depth].

The test involves driving a 60° (or 30°) cone by means of 8kg hammer sliding on a 16mm diameter steel rod through a drop of 575mm. The shear strength measured by the test is then correlated with the California Bearing Ratio (CBR) or Unconfined Compressive Strength (UCS) by using specific graphs. The test provides quick results; however, its accuracy could be jeopardized by several factors, including (but not limited to):

- *Moisture content of the material:* - dry material produce higher CBR values than wet or saturated material (e.g. clay, silt, etc).
- *Grading of the material:* - presence of an individual particle of stone (or any hard material) in the line of the cone might mislead the results to a high CBR contrary to the actual quality.
- *Inclination of the instrument:* - give erroneous results by affecting the direction of the cone and free fall of the hammer.

Test procedure:

- 1) Assemble the instrument per the instruction manual and position it on the leveled surface at the point to be tested.
- 2) Hold the instrument vertically on the ground, place the cone on the surface and take the initial reading on the scale rule.
- 3) Lift the hammer to its upper limit and allow it to drop freely (10 times for hard layers and 5 or 3 times for weak layers) and record the scale reading after the number of blows.
- 4) Continue with penetration (by applying chosen number of blows) and recording scale readings until a total penetration of 800mm or more is achieved (if the instrument inclines a bit, do not correct it unless is worse to cause the hammer slide on the shaft).
- 5) Then, plot a graph of cumulative blows on *x-axis* and cumulative penetration on *y-axis* and join the points by straight line.
- 6) Calculate the DCP values at each change of slope as follows:

$$\text{DCP value} = \frac{\text{Cumulative Penetration (depth)}}{\text{Cumulative Number of blows}}$$

- 7) Interpolate the CBR values on the DCP/CBR Correlation chart.

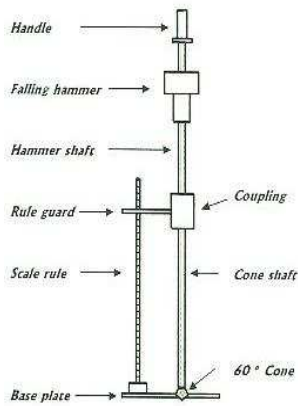

DCP Instrument

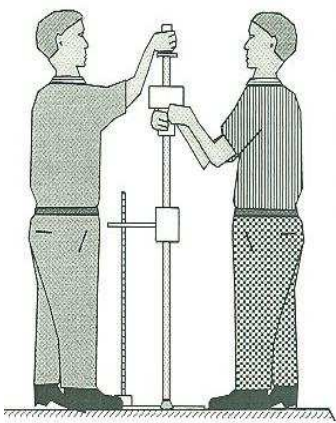

DCP Test

5.7. Specific gravity

Specific gravity is the ratio of density of a solid particle (including sealed voids) to the density of distilled water at a specific temperature (preferably 25 °C). It is used for evaluation of various parameters (e.g. calculation of volumes, plotting air voids' line in Proctor test, etc). The test applies the following stuff:

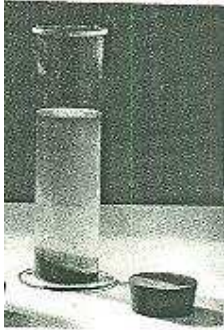

Gas jar and Stopper

Fine material: - small particles passing 2.0mm sieve (BS) or 4.75mm sieve (AASHTO).

Coarse material: - large particles retained on 2.0mm sieve (BS) or 4.75mm sieve (AASHTO).

Gas jar: - glass cylinder (of about 1L) used to determine specific gravity of coarse materials.

Rubber stopper: - conical rubber used to close gas jar.

Pycnometer: - a glass bottle with calibration mark at the neck, used to determine specific gravity of fine materials.

Test procedure:

- 1) Dry sample in oven (at 105 °C – 110 °C) to constant weight.
- 2) Weigh and record the weight of gas jar or pycnometer (m_1).
- 3) Fill pycnometer or a gas jar with sufficient amount of soil (about 50g for pycnometer or 300g for gas jar) and record its weight (m_2).
- 4) Add distilled water to the jar or pycnometer just to cover up the soil and close it with a stopper.
- 5) Shake the sample for 20 – 30 minutes (or apply a vacuum pump for at least 1 hour).
- 6) Then, remove the stopper, add more water to reach the calibration mark and record the total weight of pycnometer + sample + water (m_3).
- 7) Empty the jar or pycnometer, clean it, fill it with distilled water to the calibration mark and take its weight (m_4).



Small Pycnometer

Calculation:

$$\text{Specific gravity of soil } (G_s) = \frac{(m_2 - m_1)}{(m_4 - m_1) - (m_3 - m_2)}$$

Chapter 6

Asphalt Materials



Asphalt Paving

Asphalt is the material of choice for heavy traffic roads due to its strength, durability and ease of maintenance and rehabilitation. It is also ideal for urban roads due to speed of construction, noise reduction, better surface drainage and ease of cleaning.

Asphalt composition consists of bitumen and aggregates in a definite proportions. Bitumen combines with filler to produce mastic paste that binds the aggregate particles and fills the voids in the aggregate blend; while aggregates provide adequate strength and skid-resistance for the layer.

6.1. Bitumen

Bitumen is a fluid binder produced by distillation of crude oil. Its chemical composition consists of Carbon and Hydrogen, parked in three parts of *oil*, *resin* and *asphaltenes*. Asphaltenes is the main body of the compound; resin provides adhesion and ductility property, while oil provides viscosity.

a) The common types of bitumen:

- *Penetration grade bitumen*

Semi-solid bitumen, which allow a 1mm needle to penetration a depth ranging from 40mm – 300mm.

- *Cutback bitumen (Road oil)*

Liquid bitumen, obtained by diluting semi-solid bitumen with solvents (e.g. petrol, kerosene or diesel). This type includes:

- o *Rapid Curing (RC)*:- liquid bitumen diluted with quick-evaporating solvent - *petrol* (dries quickly).
- o *Medium Curing (MC)*:- liquid bitumen diluted with moderate-evaporating solvent - *kerosene* (takes moderate time to dry). This group includes MC30 and MC70 for prime coat and MC3000 for surface dressing (in a cold climate).
- o *Slow Curing (SC)*:- liquid bitumen diluted with slow-evaporating solvent - *diesel* (dries slowly).



Asphalt Core



Penetration Test

- ***Bitumen emulsion***

Liquid bitumen obtained by diluting semi-solid bitumen with water and emulsifying agents (the agents disperse bitumen in small droplets that later on combine again after evaporation of water). The main types are; *Ionic emulsion* and *Cationic emulsion*.

b) The common bitumen tests:

- ***Penetration test***

The test measures resistance to penetration (hardness) of semi-solid bitumen at normal temperature (25 °C).

A weighted needle of 100g is allowed to penetrate for 5 seconds on the surface of a semi-solid bitumen sample kept at 25 °C. The penetration is then recorded and reported to a unit of 0.1mm (for instance, 80/100 penetration grade is a semi-solid bitumen, which the test needle is able to penetrate 8mm – 10mm).

The common grades are; 40/50, 50/60, 60/70, 70/80, 80/100, 100/120, 120/150, 150/200 and 200/300. However, the most applicable grades in Tanzania are the 40/50 and 60/70 for asphalt mixes and 80/100 for surface treatments (or for asphalt mixes in a cold climate).

- ***Softening point***

The test measures temperature at which bitumen becomes elastic. It is known by another name as *Ring and Ball test*.

A confined sample of bitumen is loaded with small steel balls and suspended in a glass beaker filled with water. The water is heated until bitumen becomes soft enough to allow the balls to drop on the beaker; and the temperature is recorded as the *softening point*.

- ***Viscosity test***

The test measures consistence (fluidity) of cutback bitumen at specific temperature (preferably, 60 °C).

A given volume of cutback bitumen is heated in a standard cup with specific orifice size. First, the orifice is closed and the cup is filled with bitumen and heated to 60 °C. After attaining the temperature, the orifice is opened and the time (in seconds) taken by the fluid bitumen to flow out and fill a volume of 60ml is recorded (e.g. MC70 means *Medium Curing* cutback bitumen that takes 70 seconds to flow and fill a volume of 60ml).



Ball and Ring Test

6.2. Asphalt Mix Design

Asphalt concrete (AC) or Hot Mix Asphalt (HMA) is produced by mixing aggregates and bitumen in definite proportions. Bitumen combines with filler to produce a mastic paste that binds the aggregate particles together and fills the voids formed in the aggregates; while, aggregates provide adequate strength and skid-resistance for the layer.

There are three methods commonly used in designing asphalt mixes (however, some of the methods are country-specific):

- *Hveem Method:* - Developed by Francis Hveem of the California Department of Transportation. The method is based on the *stability* (measured by triaxial-type test cell), *swell* (resistance of mix to effect of water) and *density/voids* properties of the mixture (containing aggregates with maximum size of 25mm or less). However, the kneading compaction and stability measurement represent the actual loading conditions in a pavement layer; the method is not common in East Africa and other SADC countries.
- *Superpave Method:* - Established by the Strategic Highway Research Program (SHRP) to improve the performance and durability of USA roads. The system is also based on the volumetric proportioning of aggregate mixture as developed by Bruce Marshall, but brings out new method of conducting laboratory compaction and performance testing. The system uses a *Gyratory Compactor* instead of the Marshall Compactor and the actual performance is estimated by computer software based on shear and indirect tensile strength instead of the Marshall Stability and flow. The system is not concluded yet, as it is still under performance trial in some countries including Tanzania (Dar – Bagamoyo Road, *Wazo hill* – *Bunju B* section). Therefore, further improvements are still awaited.
- *Marshall Method:* - Developed by Bruce Marshall of the Mississippi State Highway Department. The method is based on volumetric proportioning of the aggregate mixture (containing maximum size of 25mm or less) and the main consideration being *stability/flow* and *density/voids* properties. It is the most applicable method in asphalt mix design (however, it is facing critics that the impact compaction produced by Marshall Compactor and the stability testing method do not represent the nature of actual loads as they occur in a pavement layer).



Marshall hammer & Moulds



Marshall Tester



Marshall Hammer



Electric Oven

Marshall Mix Design:

- 1) Start the process by examining the materials properties:
Bitumen - Penetration test, Ring and ball test and Specific gravity from Certificate of quality supplied with bitumen.
Aggregates - Grading, Shape, Strength (ACV or TFV), Sulphate Soundness, Specific gravity and Water absorption.
- 2) Make arithmetic combination (by trial and error) of different sizes of aggregate to get a continuous curve, which fits well in the specified grading limits (envelop).
- 3) Determine the properties of aggregate blend before mixing with hot bitumen as follows;

a) Compacted Density of Mixed Aggregates (CDMA)

CDMA value is used to evaluate the amount of air voids in the aggregate blend before adding bitumen.

Compact the aggregate blend in a Marshall mould in 3 layers with 25 blows of the Marshall hammer to each layer (or compact the mix in 4 layers in a small proctor mould using 20 blows of the 4.5kg rammer to each layer). Then, weigh the material and calculate the compacted density as follows:

$$CDMA = \frac{\text{Weight of compacted aggregates}}{\text{Volume of the mould}}$$

b) Specific Gravity of Mixed Aggregates (SGMA)

SGMA value is used to evaluate air voids in the mix after adding bitumen. It is calculated based on the individual proportion and specific gravity of each aggregate fraction:

$$SGMA = \frac{100}{\frac{\% \text{ Filler}}{SG_{\text{filler}}} + \frac{\% \text{ Fine}}{SG_{\text{fine}}} + \frac{\% \text{ Medium}}{SG_{\text{medium}}} + \frac{\% \text{ Coarse}}{SG_{\text{coarse}}}}$$

c) Voids in Mixed Aggregates (VMA)

VMA value is used for estimating the quantity of bitumen required to fill air voids in the aggregate blend to an acceptable limit. High VMA value means the mix is too porous and require extra amount of bitumen to fill the extra voids and the low value means the mix is too dense to accommodate sufficient bitumen for mix flexibility (recommended range is 17 – 20 %).

$$VMA = \frac{(SGMA - CDMA) \times 100}{SGMA}$$



Asphalt Quartering

- 4) Once the VMA has been determined, blend the aggregates in the selected proportions to obtain about 1200g for each specimen (prepare at least 3 specimens for each binder content).
- 5) Heat aggregates and bitumen to the required degrees (e.g. 165 °C for 40/50; 160 °C for 60/70; 150 °C for 80/100 and 140 °C for 150/200 pen grade bitumen).
- 6) Once temperature is attained, mix the materials immediately with different percentages of bitumen at increment of 0.2 % (gives better results than the increment of 0.5%, which gives scattered values). Prepare 4.4, 4.6, 4.8, 5.0, 5.2, 5.4 % for coarse grading (2 – 6% passing 0.075mm) and 4.8, 5.0, 5.2, 5.4, 5.6 and 5.8 % for fine grading (6 – 10% passing 0.075mm).
- 7) Compact the mix at 10 °C below the mixing temperature (i.e. at 155 °C for 40/50; 150 °C for 60/70; 140 °C for 80/100 and 130 °C for 150/200 pen grade bitumen); or apply 90 °C + Ball and Ring temperature. Then, proceed with the compaction as follows:
 - Pre-heat Marshall mould in oven for few minutes.
 - Put hot mix in the mould and chop the material along the perimeter of the mould with a hot spatula.
 - Give each side of the specimen 75 blows of the Marshall hammer.
 - Allow specimen to cool, then extrude it out of the mould
 - Clean the specimen with a wire brush to remove loose particles.
 - Determine the weight of specimen in *air* and in *water*.

Calculations:

• **Compacted Density of Mix (CDM) or (Gmb)**

$$CDM = \frac{Wt. \text{ of specimen in air}}{Wt. \text{ of specimen in air} - Wt. \text{ of specimen in water}}$$

• **Specific Gravity of Mix (SGM) or (Gmm)**

$$SGM = \frac{100}{\frac{\% \text{ Bitumen}}{SG_{bitumen}} + \frac{\% \text{ Aggregates}}{SG_{aggregates}}}$$

Note: It is recommended to measure *Gmm* by desiccators and vacuum pump (Rice's method).



Desiccators and Vacuum Pump

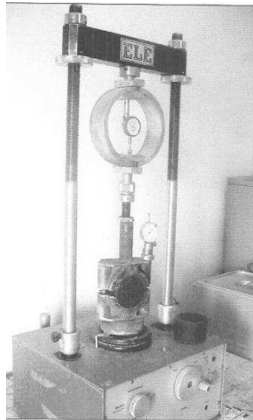

Stability Testing

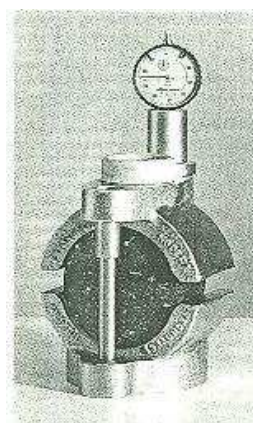

Crushing head and Flow gauge

• Voids in Mix (VIM)

High VIM value means brittle and porous mix that may absorb water and break under traffic loading (resulting in fatigue cracks and potholes), while low value means dense mix that have no space to accommodate bitumen squeezed by traffic loads (therefore, resulting in bleeding and shoving). The recommended range is 3 – 6 %.

$$VIM = \frac{(SGM - CDM) \times 100}{SGM}$$

• Stability and Flow

Stability test measures the load bearing capacity, while Flow test measures deformation caused by the maximum load. The two tests are carried out concurrently.

a) Stability test:

- Immerse specimen in water bath at 60 °C for 30 – 40 minutes.
- Then, crush the specimen one after another in the Marshall tester running at a constant rate of 50mm/minute.
- Record the maximum load attained by each specimen [use the ring factor to convert the readings into forces].
- Multiplying the force by correlation ratio for volume of specimen to get corrected *Stability value*.

Table 6.1 – Correlation ratios for volume of specimen

Volume (cm ³)	Ratio
471 – 482	1.14
483 – 495	1.09
496 – 508	1.04
509 – 522	1.00
523 – 535	0.96
536 – 546	0.93
547 – 559	0.89

b) Flow test:

- During stability test, place a flow gauge on the Crushing head and record the initial reading (*r1*) when the head has already touched the specimen then, continue with the crushing process.
- Read the flow gauge immediately when the load reaches the maximum value (*r2*).
- Calculate flow as the difference of initial reading and final reading (i.e. *r2 – r1*).



Pan Centrifuge

• Bitumen Content

Conduct bitumen extraction test (washing the asphalt mix with solvent to remove bitumen and remain with neat aggregate).

- Take about 2000g of the mix and determine its weight ($m1$).
- Place the sample in a centrifuge, add solvent to cover the material, put filter paper on the rim and close the pan.
- Start the machine and allow it to rotate until solvent flow comes to an end.
- Stop the machine, add solvent and rotate the machine again (repeat this operation until the solvent coming out is clean).
- Dry the washed aggregate in oven to constant weight.
- Allow the aggregate to cool then determine its weight ($m2$).
- Calculate bitumen content as follows;

- Bitumen content (*per total mix*) =
$$\frac{(m1 - m2) \times 100}{m1}$$

- Bitumen content (*per wt. of aggregate*) =
$$\frac{(m1 - m2) \times 100}{m2}$$

- Draw graphs of bitumen contents against *density, stability, flow, VIM, VMA* and plot out the optimum value for each property as illustrated in the table below;

Specified Properties:	STABILITY (KN)	FLOW (mm)	VIM (%)	VMA (%)
Property Limits:	7 – 15	2 – 4	3 – 6	Min. 15
Then, plot bitumen at the following values:	11 kN	3 mm	5 %	17 %

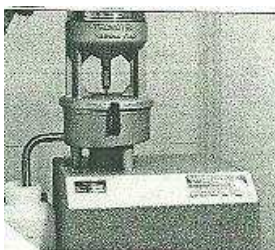

Steady-flow Centrifuge

- Sum up the binder contents plotted for each property and calculate the average value as the *Optimum Binder Content*.
- Carry out grading of the aggregate and plot its curve in the grading limits for comparison with the grading specification.
- Confirm the mix properties at the optimum binder content by preparing three mixes; one at the optimum binder content and other two at 0.1% lower and higher than the optimum value.
- Evaluate the properties of the mixes against the project specifications and adopt the binder content of the mix that complies (or adjust the binder and re-run the trial if the properties do not comply with the project specifications).

Examples:

PROJECT	TAIFA AVENUE	CHECKED BY:
LOCATION	KM. 1+500 - 1+800 (Full width)	
LAYER	WEARING COURSE	DATE:
MATERIAL	ASPHALT CONCRETE (AC20)	APPROVED BY:
TECHNICIAN	MAX / ADAM / MORONYI	
DATE	JAN. 2003	

PROPERTIES OF MARSHALL SPECIMENS

PROPORTIONS																	
A	Bitumen content (per total mix)	%	4.8	5.0	5.2	5.4	5.6										
B	Aggregate content (per mix) (100 - A)	%	95.2	95.0	94.8	94.6	94.4										
C	Spec. gravity of bitumen (80/100 grade)	g/cm ³	1.02	1.02	1.02	1.02	1.02										
D	Spec. gravity of Mixed Aggregate	g/cm ³	2.680	2.680	2.680	2.680	2.680										
DENSITY																	
	Specimen identity	No.	F1	F2	F3	F4	F5	F6	F7	F8	F9	F10	F11	F12	F13	F14	F15
	Height of Specimen	mm	65.3*	64.10	63.14	63.34	63.12	64.27*	62.39	63.24	62.42	63.08	62.58	62.76	62.58	63.81	65.53
E	Weight of specimen in air	g	1201.6	1201.6	1185.9	1192.0	1192.3	1191.2	1192.2	1190.5	1195.4	1185.0	1191.1	1184.6	1191.1	1192.8	1215.6
F	Weight of specimen in water	g	684.8	689.2	681.2	691.4	691.0	686.2	691.3	691.5	692.7	686.3	690.8	687.1	690.2	691.7	703.8
G	Weight of specimen (ssd) in air	g	1203.6	1201.9	1186.8	1192.8	1193.2	1193.3	1192.8	1191.5	1195.9	1185.5	1191.8	1186.2	1192.2	1194.0	1216.4
V	Volume of specimen (G-F)	cm ³	518.8	512.7	505.7	501.4	502.1	507.1	501.5	500.0	503.2	499.2	501.0	499.1	502.0	502.3	512.5
H	Density of specimen (E/V)	g/cm ³	(2.316)*	2.344	2.345	2.377	2.375	(2.349)*	2.377	2.381	2.375	2.374	2.377	2.374	2.373	2.375	2.372
		AVE.	2.344			2.376			2.378			2.375			2.373		
I	Max. Theoretical Density $\frac{100}{(A/C) + (B/D)}$	g/cm ³	2.486			2.478			2.471			2.464			2.456		
VOIDS																	
J	Volume of bitumen (% mix) A x H/C	%	11.0			11.6			12.1			12.6			13.0		
L	Voids In total Mix (VIM) $100 \times (I-H)/I$	%	5.7			4.1			3.8			3.6			3.4		
M	Voids in Mineral Aggregate (VMA)	%	16.7			15.8			15.9			16.2			16.4		
N	Voids Filled with Bitumen (VFB)	%	66.0			73.8			76.3			77.8			79.4		
STABILITY																	
P	Marshall Stability (dial gauge reading)		(340)*	380	380	510	498	(380)*	500	480	470	460	450	452	440	450	400
R	Marshall Stability (converted to force)	N	7694	8599	8599	11541	11270	8599	11315	10862	10636	10410	10184	10229	9957	10184	9052
S	Correlation ratio (for volume)		1.00	1.00	1.04	1.04	1.04	1.04	1.04	1.04	1.04	1.04	1.04	1.04	1.04	1.04	1.00
T	Marshall Stability (adjusted)	N	(7694)*	8599	8943	12003	11721	(8943)*	11768	11297	11062	10826	10591	10638	10355	10591	9052
		AVE.	8.771			11.862			11.375			10.685			10.473		
FLOW																	
U	Initial dial gauge reading	mm	9.12	10.23	7.24	8.14	10.20	9.30	8.89	9.71	10.01	8.97	9.71	9.45	10.02	11.14	9.87
V	Final dial gauge reading	mm	11.01	12.33	9.42	10.43	12.45	11.31	11.76	12.36	12.63	12.09	12.95	12.71	14.12	15.14	13.76
W	Marshall Flow (V - U)	mm	(1.89)*	2.10	2.18	2.29	2.25	(2.01)*	2.87	2.65	2.62	3.12	3.24	3.26	4.10	4.00	3.89
		AVE.	2.1			2.3			2.7			3.2			4.0		
QUOTIENT																	
	Marshall Quotient (T/W)	kN/mm	4.1			5.2			4.2			3.3			2.6		
* The values with stars are outliers (they are not included in the average due to big variation from others specimens of the same group)																	
	Correlation ratios	volume of specimen	421-431	432-443	444-456	457-470	471-482	483-495	496-508	509-522	523-535	536-546	547-559	547-559			
		Correlation ratio	1.39	1.32	1.25	1.19	1.14	1.09	1.04	1.00	0.96	0.93	0.89	0.89			

The mix properties:



Marshall Specimen

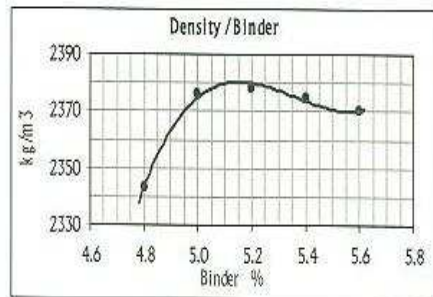
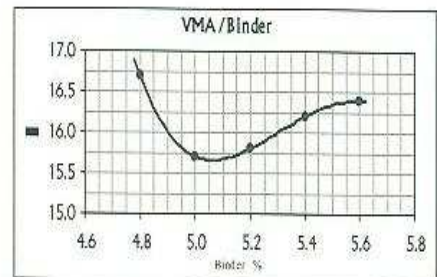
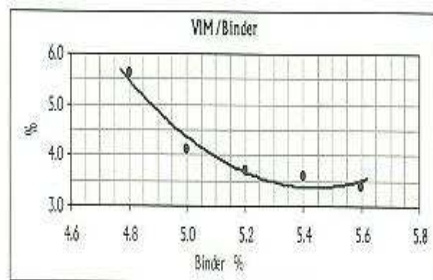
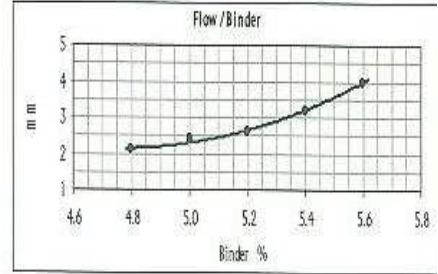
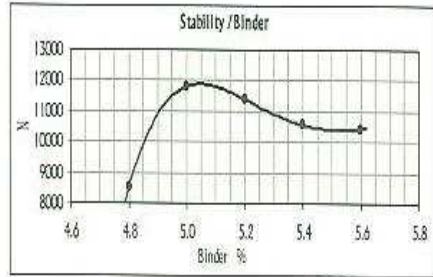

BINDER SELECTION:	
For:	
STABILITY:	4.9 %
FLOW:	5.3 %
VIM:	4.9 %
VMA:	4.9 %
DENSITY:	4.9 %
AVERAGE:	5.0 %



Asphalt Sampling

• **Trial Mix**

Set the mix proportions to the asphalt plant, produce a reasonable quantity of asphalt for site trial and control tests:

- Take a representative sample (from different sides of the stockpile) for the control tests (binder content, stability, flow, density and voids).
- Prepare a trial section, pave the mix to the required thickness, control the compaction (roller passes) and cut cores for density/voids analysis; and thickness measurement.
- Once production is stable, set the working tolerances by adjusting the grading limits.

PROJECT	TAIFA AVENUE	CHECKED BY:
LOCATION	KM. 1+500 - 1+800 (Full width)	DATE:
LAYER	WEARING COURSE	APPROVED BY:
MATERIAL	ASPHALT CONCRETE (AC20)	DATE:
TECHNICIAN	MAX / ADAM / MORONYI	
DATE	JAN. 2003	

EXTRACTION & GRADING

EXTRACTION					FLAKINESS INDEX			
Sample No.		1	2	3	Size	Total Wt.	Wt. Retain.	Wt. Passing
	Design bitumen content	%	4.8	5.0				
A	Wt. of Asphalt mix before extraction	g	1602.62	1692.95	28 - 20	0	0	0
B	Wt. of Aggregate after extraction	g	1516.21	1604.09	20 - 14	220.3	184.6	35.7
C	Wt. of Filter paper before extraction	g	9.02	9.13	14 - 10	345.6	291.5	54.1
D	Wt. of Filter paper after extraction	g	9.13	9.31	10 - 6.3	311.7	257.1	54.6
E	Wt. of Fines in filter paper (D - C)	g	0.11	0.18				
F	Wt. of Cup + Filler	g	285.04	287.88				
G	Wt. of empty Cup	g	274.37	281.43				
H	Wt. of Filler (F - G)	g	10.67	6.45				
J	Total Wt. of aggregate (B+E+H)	g	1526.99	1610.72	Fl =	Sum of Wt. Passing / Sum of Total Wt.		16.5
K	Wt. of Bitumen (A - J)	g	75.63	82.2				
L	Actual bitumen content (per mbx) (K/A) x100	%	4.7	4.9	PROJECT SPECIFICATION			25 Max.

GRADING										
Sample No.	1			2			3			Grading Limits
Wt. of Agg.	1526.99			1610.72			1532.97			
Sieve(mm)	wt. Retained	% Retained	% Passing	wt. Retained	% Retained	% Passing	wt. Retained	% Retained	% Passing	% Passing
28	0	0.0	100.0	0.0	0.0	100.0	0	0.0	100.0	100
20	21.28	1.4	98.6	11.89	0.7	99.3	42.40	2.8	97.2	94 - 100
14	177.48	11.6	88.4	189.42	11.8	88.2	183.60	12.0	88.0	84 - 94
10	361.42	23.7	76.3	405.61	25.2	74.8	382.60	25.0	75.0	71 - 82
5	635.37	41.6	58.4	708.28	44.0	56.0	651.78	42.5	57.5	52 - 65
2.36	851.32	55.8	44.2	909.99	56.5	43.5	838.51	54.7	45.3	40 - 50
1.18	1030.65	67.5	32.5	1097.69	68.1	31.9	1022.96	66.7	33.3	26 - 36
0.600	1199.21	78.5	21.5	1269.38	78.8	21.2	1182.28	77.1	22.9	15 - 26
0.300	1285.14	84.2	15.8	1371.69	85.2	14.8	1283.01	83.7	16.3	11 - 19
0.150	1378.17	90.3	9.7	1457.34	90.5	9.5	1380.58	90.1	9.9	7 - 13
0.075	1445.10	94.6	5.4	1528.11	94.9	5.1	1441.93	94.1	5.9	4 - 8

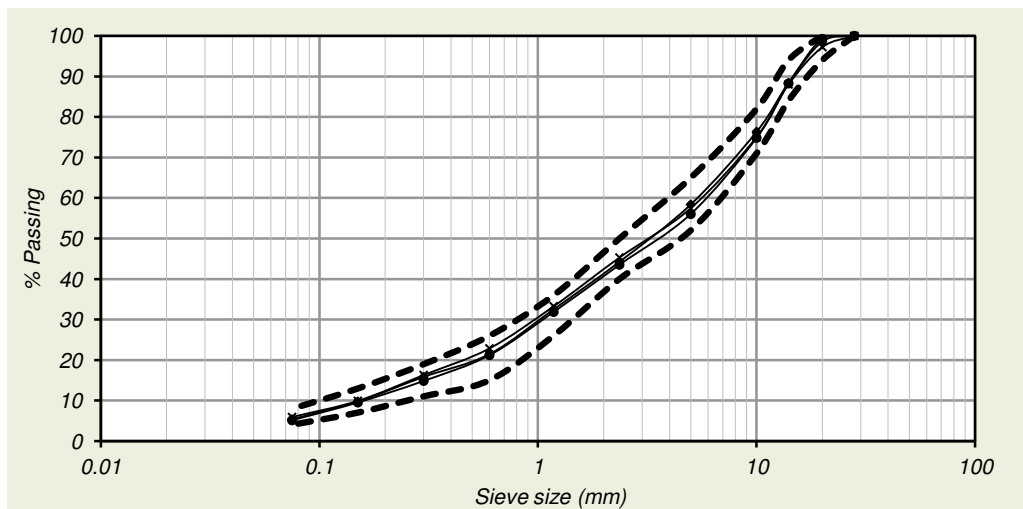

6.3. Immersion index

The test measures effect of water on the stability of compacted asphalt mix. The index of retained strength is calculated by comparing the stability of immersed specimen with the stability of fresh specimen (cured in air). It is also known as *Retained stability*.



Compacted specimens

Test Procedure:

- 1) Prepare at least 6 Marshall Specimens and allow them to cool for at least 2 hours.
- 2) After cooling, determine the bulk density of each specimen.
- 3) Sort the specimens into two groups of three specimens, so that the average bulk densities of the two groups are almost equal.

Group 1

Keep three specimens at 25 °C for at least 4 hrs and then determine their Marshall Stability (*F1*)

Group 2

Immerse other three specimens in a water bath at 49 °C for 4 days. After 4 days, transfer them into the second water bath kept at 25 °C for 2 hrs and then determine their Marshall Stability and record the average value (*F2*).

Alternatively,

Immerse the specimen in a water bath at 60 °C for 24 hrs. After that transfer them into the second water bath kept at 25 °C for 2 hrs and then determine their Marshall Stability and record the average value (*F2*).

- 4) Calculate the index of Retained Stability as follows:

$$I = \frac{F2 \times 100}{F1}$$

Where:

I = Immersion index

F1 = Stability of dry specimen (Group1)

F2 = Stability of immersed specimen (Group 2)



Water bath

Surface Treatment



Surface Treatment

Surface treatment is a method of covering the roadbase with a layer or layers of bitumen and chippings. The method is known by other names as *surface dressing*, *chip seal*, *sprayed seal* or *chip and spray*. It is carried out by applying a hot bitumen membrane on the roadbase and spreading chipping on it (in single, double or triple layers). The function of bitumen is to bind the chipping on the base and to seal the surface against ingress of water, while the chipping provides hard and durable riding surface.

7.1. Binder

Binder used for the surface treatment must be viscous enough to hold the chipping against dislodging effect of traffic tyres. Still, it must remain flexible at low temperatures to allow slight deflections induced on the road surface by the traffic tyres.

The common types of binder for surface treatments in Tanzania are 80/100 pen, 150/200 pen and MC3000 cutback (for cold regions with temperature that does not exceed 15 °C). However, under normal traffic conditions and tropical temperatures, 80/100 penetration grade takes preference.

7.2. Chipping

Chippings are single-sized aggregate particles ranging from 5mm to 20mm (however, sand is also applicable in some cases). For the chipping to perform satisfactorily, the particles should be clean, cubic, rough, hard and strong enough to resist traffic forces and exposure conditions.

To ensure that the chipping have the desired quality for a particular application, the following tests are normally carried out:

- *Grading*:- Proves if particles are of desired size (e.g. 6mm, 10mm, 14mm or 20mm) and are free from dust.
- *Shape tests*:- Flakiness and elongation indices reveal the dimensions of particles (as flaky and elongated particles affect the interlocking property and layer thickness).



Chipping



Aggregate Production

- *Dust content*:- Blots the surface of chipping and prevents adhesion of bitumen.
- *Los Angeles abrasion (LAA)*:- Measures the ability to resist wear.
- *Aggregate crushing value (ACV)*:- Measures the ability of chipping to resist crushing (during rolling).
- *Sulphate soundness*:- Measures the ability of chipping to resist chemicals (especially salts).

7.3. Application rates

The application rates (spray rate and spread rate) for the surface treatment materials depend on several factors such as; the type of road surface, chipping sizes, traffic loading and climatic conditions. Soft surfaces and heavy traffic loads cause high penetration of chipping, hence, require bigger sizes than hard surfaces and light traffic loads.

Design Procedure:

- 1) Conduct the aggregate tests (grading, shape tests, dust contents, LAA, ACV and sulphate soundness) as specified.
- 2) Carry out the coating and stripping test (sometimes known as *Bitumen affinity test*) to assess bitumen adhesion on the chippings.
 - Weigh **100g** of oven-dry chippings into a tray.
 - Place the tray with chippings in oven at 140 °C for 1 hour.
 - Heat penetration grade bitumen separately at 140 °C (or at 68 °C for MC3000) for 1 hour.
 - Add **5.5g** of hot bitumen to hot chippings in the tray and use warm spatula to mix the material vigorously until the chippings are completely coated with bitumen (if complete coating is not obtained, warm the mixture gently on a hotplate and continue mixing until coating is complete).
 - Allow the coated chippings to cool, then transfer them in a 600ml glass beaker and add **400ml** of distilled water.
 - Leave the coated chippings in water for 16 to 18 hours without disturbing the sample and remove any floating film on the surface of water.
 - Illuminate the beaker with a shaded lamp, make visual observation from above and estimate the quantity of coated chippings (thin brownish and translucent areas should be considered as coated).
 - Report the result as: **Above 95%** or **Below 95%**.



Aggregate Stockpile

- 3) Determine the *average least dimension* (ALD) of the chippings. The ALD test shows the smallest dimensions of aggregate that project up when the largest sides rest on the road surface (aggregate particles when dropped down, tend to rest on their largest dimensions and the smallest dimensions stand upright). If the projecting dimensions are very small, the chippings might penetrate totally into the roadbase, hence, leaving only bitumen membrane on the road surface (bleeding).

ALD test:

- Take about 200 particles of chippings, measure their smallest sides by calipers and report the average value as ALD (in *mm*).

Alternatively; Take sufficient chippings and carry out the flakiness index and grading tests, then, plot the sieve size at which 50% of the material passes (*median size*) and use it together with the *flakiness index* to plot ALD value on the graph below;

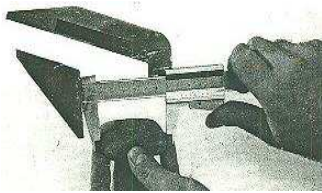

ALD measurement

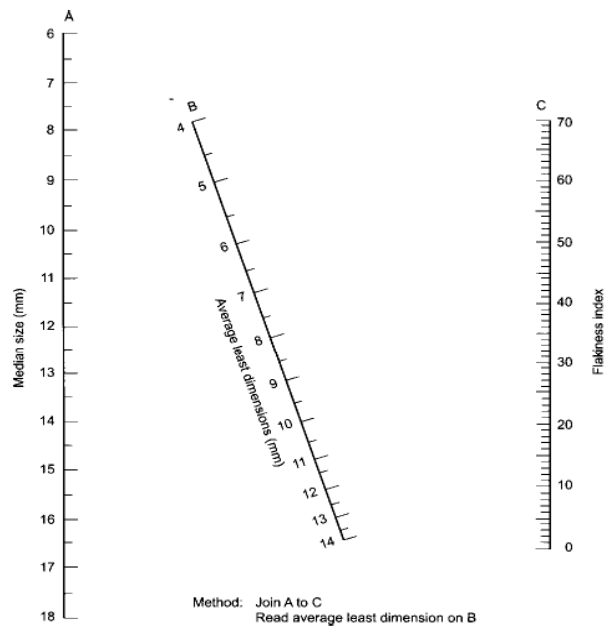

Source: Overseas Road Note 3

Figure 7: ALD chart

- 4) Determine the *Overall weighting factor* as the sum of weighting factors corresponding to the road surface, traffic, chipping, and climate conditions. Then, use the *overall weighting factor* and *ALD* to plot the rates in the graph provided in figure 8.

Table 7.1 – Weighting factors (Source: Overseas Road Note 3)



Bitumen Distributor

Surface Condition	Factor	Chipping Condition	Factor
Untreated or primed base	+6	Round or dusty	+2
Very thin bituminous	+4	Cubical	0
Thin bituminous	0	Flaky	-2
Average bituminous	-1	Pre-coated	-2
Very rich bituminous	-3		

Traffic Condition (vehicles/lane/day)	Factor	Climate Condition	Factor
Very light (0-50)	+3	Wet and cold	+2
Light (50-250)	+1	Tropical (wet & hot)	+1
Medium (250-500)	0	Temperate	0
Medium-heavy (500-1500)	-1	Semi-arid (hot & dry)	-1
Heavy (1500-3000)	-3	Arid (very dry and very hot)	-2
Very heavy (over 3000)	-5		

- Plot the spray rate of bitumen (in kg/m^2) at the intersection of ALD line and the overall weighting factor line (divide the kg/m^2 by SG of bitumen to get l/m^2).
- Plot the spread rate of chipping (in kg/m^2) at the intersection of ALD line and line AB.



Primed Surface

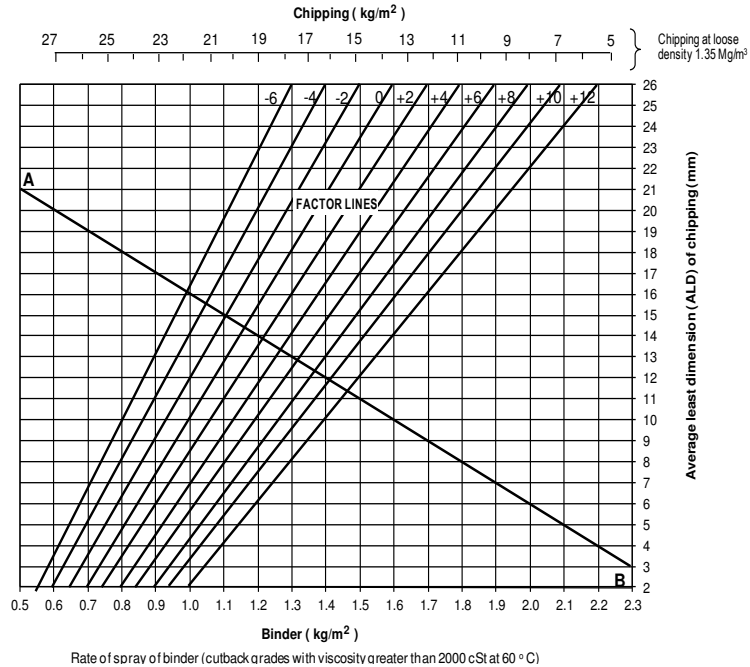

Source: Overseas Road Note 31

Figure 8: Bitumen and Chipping application rates



Typical Single Seal



Typical Double Seal

- 7) Adjust the *spray rate* obtained from the chart as follows:
- Decrease the value by 10 % for slow traffic or climbing sections with gradient steeper than 3 %.
 - Increase the value by 10 % for fast traffic or descending sections with gradient steeper than 3 %.
 - Decrease the rate by 10 % for penetration grade bitumen.
 - No adjustment is required for cutbacks (e.g. MC3000)
- 8) Make a trial section and carry out any necessary adjustment to meet site conditions.

7.4. Site Application

Surface treatments are normally applied in *single seal* for walkways, light traffic roads and for maintenance purposes; and in *double* or *triple seals* for medium and heavy traffic roads. However, experience shows that, the surface treatments perform well if applied in double or triple seals, using 80/100 penetration grade bitumen and hard and rough aggregates (e.g. granite, basalt, etc.). Normally better interlock for multi-seal is formed when chipping for the succeeding layer is about a half of the preceding layer (e.g. the seals may contain 20mm, 10mm and 6mm chipping or 20mm, 14mm and 7mm chipping; or any other equivalent sizes).

Typical rates that have shown successful performance in some projects (in Tanzania) are given in table 7.2 for guidance.

Table 7.2 – Typical application rates for Surface Treatments

Seal	Chipping size (mm)	Spray rate (bitumen) (l/m ²)	Spread rate (chipping) (kg/m ²)
1 st	20 or 19	1.0 – 1.3	14 – 16 kg
2 nd	14 or 10	0.8 – 1.0	12 – 14 kg
3 rd	7 or 5	0.6 – 0.8	10 – 12 kg
Type of Bitumen:- 80/100 penetration grade Type of Chipping:- Granite aggregates			

References

1. MINISTRY OF WORKS, TANZANIA;
Pavement and Materials Design Manual 1999
2. MINISTRY OF WORKS, TANZANIA;
CML, Laboratory Testing Manual 2000
3. TRL: Department for International Development;
Overseas Road Note 3
4. SADC Guideline on Low-volume Sealed Roads;
Pavement Design, Materials and Surfacing – July 2003
5. Thomas D. Larson;
Portland Cement and Asphalt Concretes
6. F. K. Kong and R. H. Evans;
Reinforced and Pre-stressed Concrete (3rd Edition)
7. Prof. John Atkinson; City University, London.
Lecture annotations on Soil Mechanics
8. Mike Pinard (World Bank Consultant);
Alternative Materials and Pavement Design Technologies for Low-Volume Sealed Roads + Case Studies (International Workshop, Bamako, Mali – January 2006).
9. British Standards;
BS 812: Part 101, Part 103-1, Part 105, Part 110 and Part 111
BS 1377: Part 2, Part 4 and Part 9
BS 1881: Part 102, Part 108 and Part 116
BS 8110: Part 1; Structural use of concrete
10. AASHTO:
Standard Specifications for Transportation Materials and Methods of Sampling and Testing (Part II – Tests).

Appendix 1

Simple but Confusing Terms

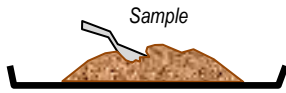

Specimen



Aggregate



Aggregates

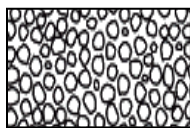
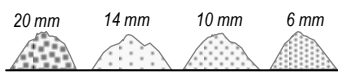

Loose density

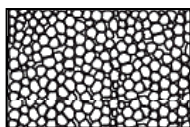

Compacted density

Sample: - small representative quantity of material collected from a source or stockpile and set aside for a test.



Soil Sample

Specimen: - moulded portion of a sample (in a definite form).



Asphalt Specimen

Aggregate: - a group of broken pieces of stone.



Aggregate (25mm nominal size)

Aggregates: - different groups of broken pieces of stone.



14 - 20 mm



10 - 14 mm



0 - 6 mm

Bulk density: - collective mass of material per unit volume (including mass of solid particles, moisture and air).

Dry density: - dry mass of material per unit volume (including mass of solid particles and air, excluding mass of moisture).

Particle density: - average mass of solid particles per unit volume (including sealed voids).

Bank density: - density of material at its natural state (undisturbed).

Loose density: - density of material after placement (before compaction).

Compacted density: - density of material at tight-packing state (after rolling, vibrating or tamping).

Unit weight: - a downward force produced by 1m^3 of material under gravity (i.e. *bank density* x 9.81 Newton).

Road in Fill

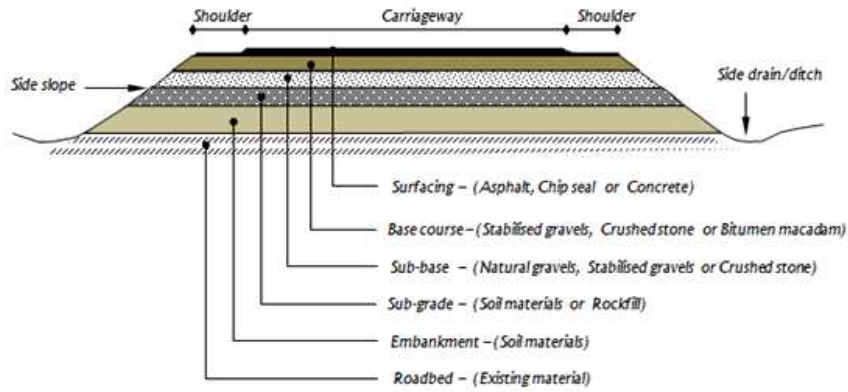

Road in Cut

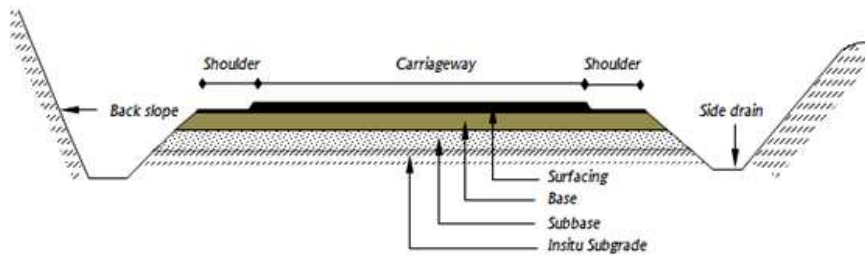

Bridge parts

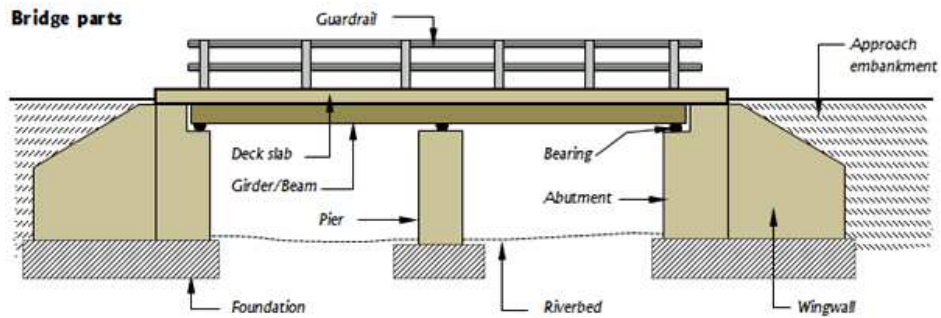

Pipe culvert

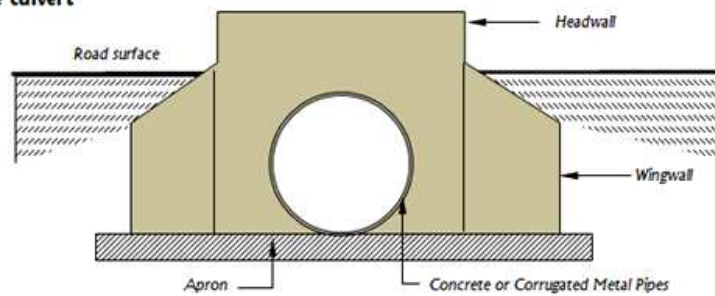

Appendix 3

Pictorial description of Road terms

What is *Traffic Overloading*?



What is *Traffic Overloading*?



What is *Road deterioration*?



What is *Road Surfacing*?



Appendix 4

Sieve Standards



The common sieves for laboratory tests are those having 203mm and 250mm diameter (however, other sizes, e.g. 300mm diameter, etc. are also available). Internal height normally varies with the sieve diameter sizes (e.g. 50mm for the 203mm diameter, 60mm for 250mm diameter and 70mm for 300mm diameter sieves). The rounded or rectangular frames are made of brass or stainless steel, while the wire-mesh or wire-cloths are made of stainless steel, brass or phosphor bronze.

Aperture sizes and equivalency:

ASTM	TYLER	AASHTO	BS
4 in.	...	100.0 mm	100 mm
3½ in.	...	90.0 mm	90 mm
3 in.	...	75.0 mm	75 mm
2½ in.	...	63.0 mm	63 mm
2.12 in.
2 in.	...	50.0 mm	50 mm
1¾ in.
1½ in.	...	37.5 mm	37.5 mm
1¼ in.	...	32.0 mm	32 mm
1.06 in.	1.05 in.	28.0 mm	28 mm
1 in.	...	25.0 mm	25 mm
7⁄8 in.	0.88 in.	22.5 mm	22 mm
¾ in.	0.74 in.	19.0 mm	20 mm
5⁄8 in.	0.62 in.	16.0 mm	16 mm
0.53 in.	0.53 in.	13.5 mm	14 mm
½ in.	...	12.5 mm	12.5 mm
7⁄16 in.	0.44 in.
3⁄8 in.	0.37 in.	9.5 mm	10.0 mm
5⁄16 in.	2½ mesh.	8.0 mm	8.0 mm
0.265 in.	3 mesh.	6.75 mm	...
¼ in.	...	6.35 mm	6.3 mm
No 3½	3½ mesh.	5.66 mm	...
No.4	4 mesh.	4.75 mm	5.0 mm
No.5	5 mesh.	4.00 mm	4.0 mm
No.6	6 mesh.	3.36 mm	3.35 mm
No.7	7 mesh.	2.83 mm	...
No.8	8 mesh.	2.36 mm	2.36 mm
No.10	9 mesh.	2.00 mm	2.0 mm
No.12	10 mesh.	1.70 mm	1.70 mm
No.14	12 mesh.	1.40 mm	...
No.16	14 mesh.	1.18 mm	1.18 mm
No.18	16 mesh.	...	1.0 mm
No.20	20 mesh.	850 µm	800 µm
No.25	24 mesh.
No.30	28 mesh.	600 µm	600 µm
No.35	32 mesh.	500 µm	...
No.40	35 mesh.	425 µm	425 µm
No.45	42 mesh.	350 µm	...
No.50	48 mesh.	300 µm	300 µm
No.60	60 mesh.	250 µm	...
No.70	65 mesh.	210 µm	212 µm
No.80	80 mesh.
No.100	100 mesh.	150 µm	150 µm
No.120	115 mesh.	125 µm	125 µm
No.140	150 mesh.	100 µm	100 µm
No.170	170 mesh.	90 µm	90 µm
No.200	200 mesh.	75 µm	...
No.230	250 mesh.	...	63 µm
No.270	270 mesh.
No.325	325 mesh.
No.400	400 mesh.

