

Sequential Circuit (Register & Counter)

Parallel In/Serial Out Shift Registers

- Bits are entered simultaneously, but output is serial.

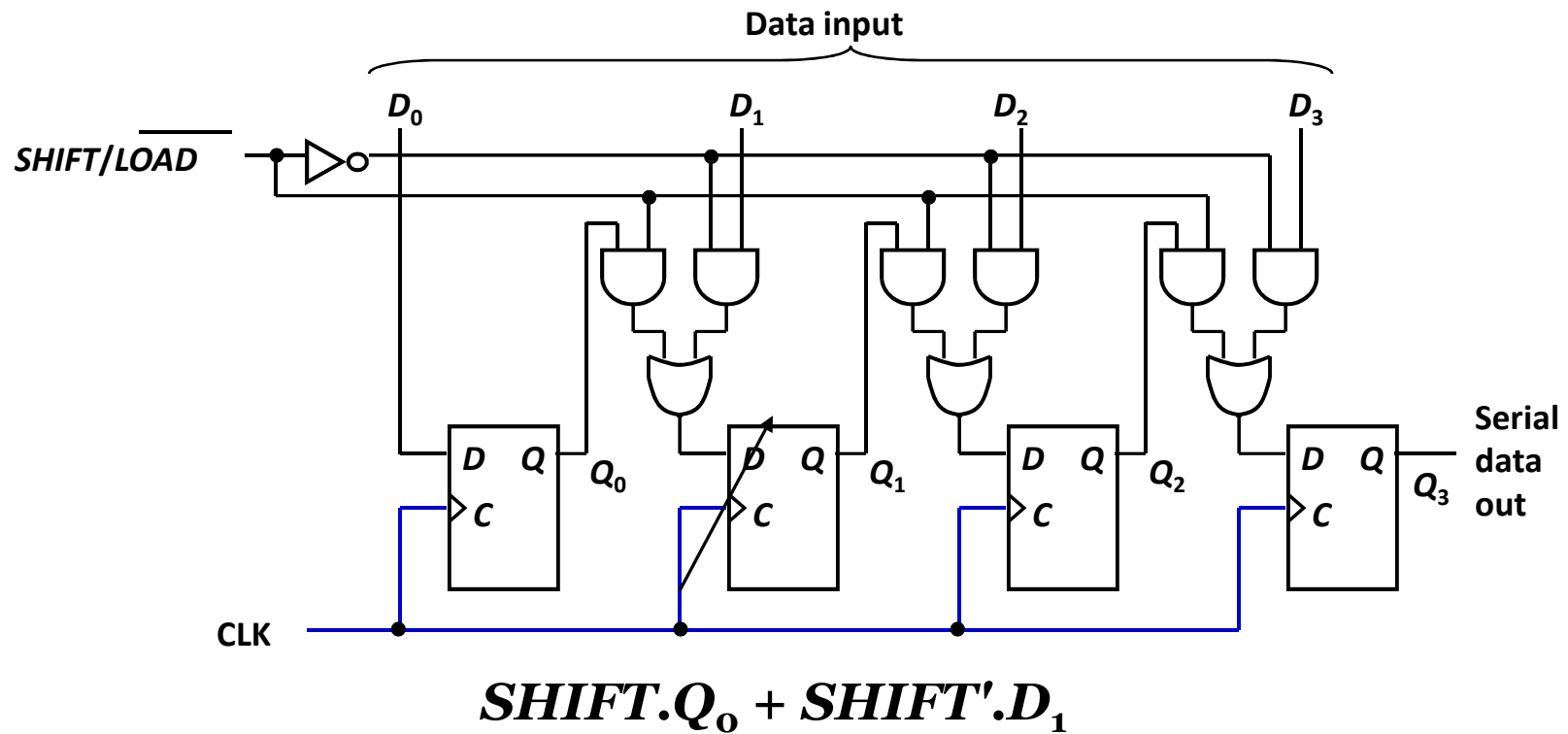

Parallel In/Serial Out Shift Registers

- Bits are entered simultaneously, but output is serial.

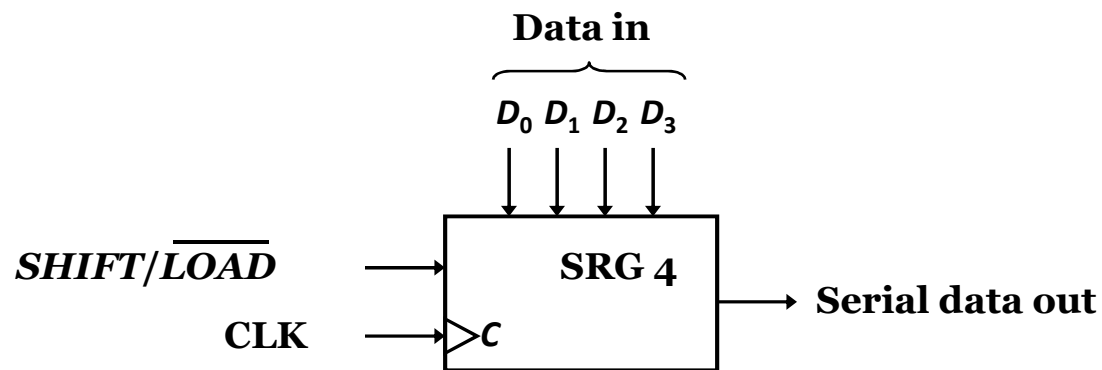

Logic symbol

Parallel In/Parallel Out Shift Registers

- Simultaneous input and output of all data bits.

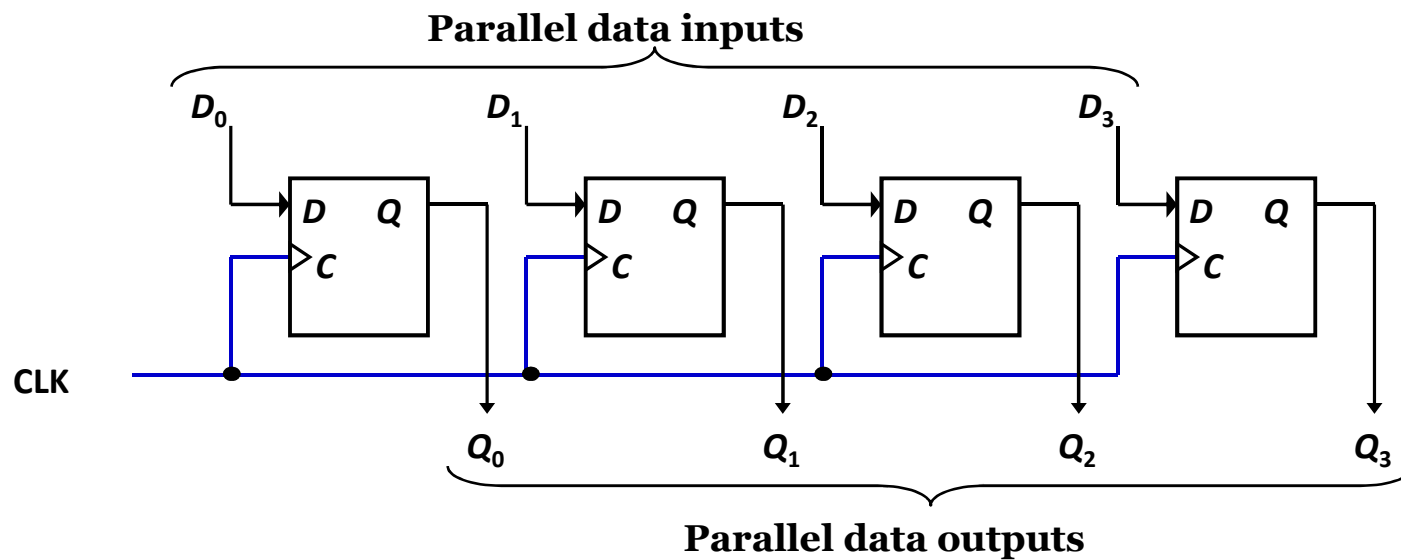

Bidirectional Shift Registers

- Data can be shifted either left or right, using a control line $RIGHT/\overline{LEFT}$ (or simply $RIGHT$) to indicate the direction.

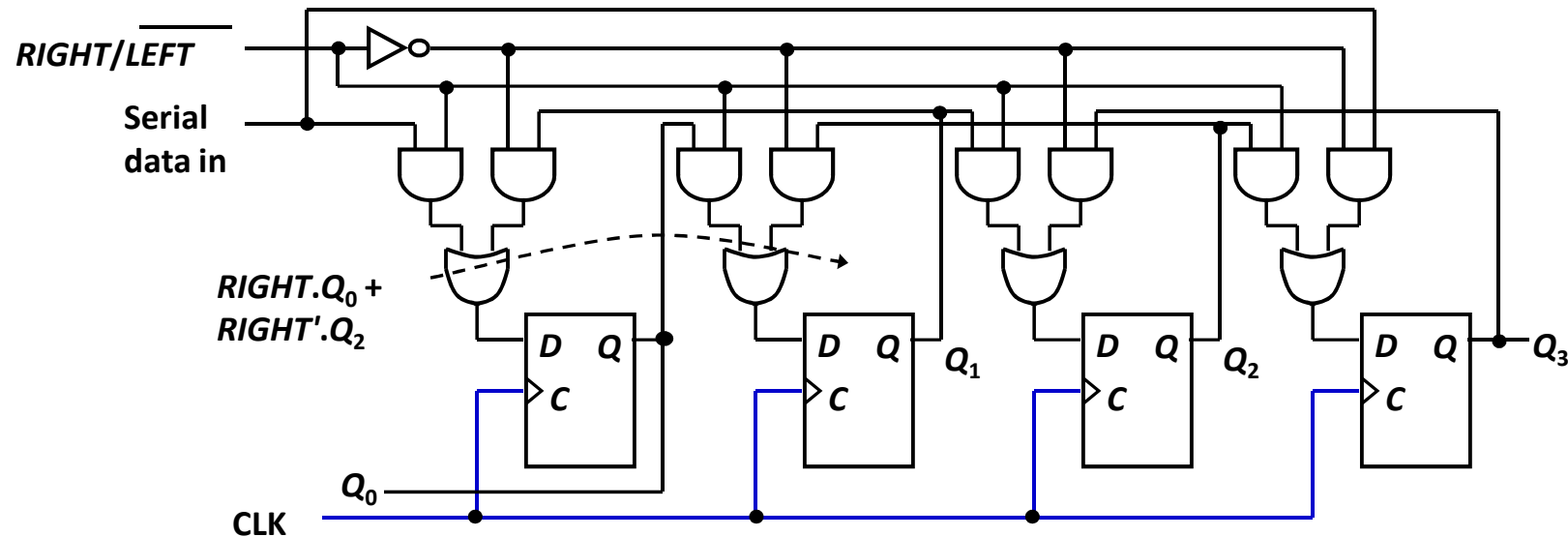

Bidirectional Shift Registers

- 4-bit bidirectional shift register with parallel load.

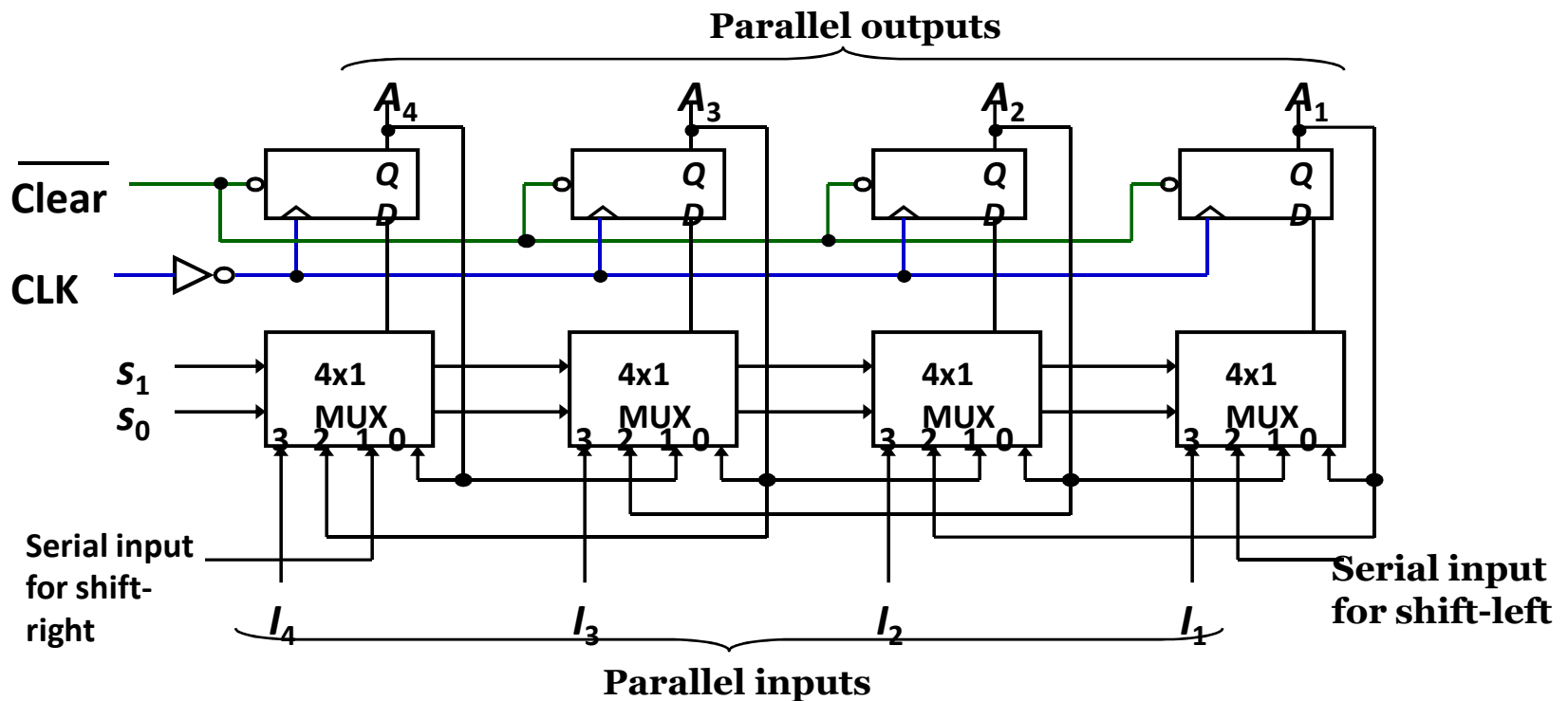

Bidirectional Shift Registers

- 4-bit bidirectional shift register with parallel load.

<i>Mode Control</i>		<i>Register Operation</i>
<i>s₁</i>	<i>s₀</i>	
0	0	No change
0	1	Shift right
1	0	Shift left
1	1	Parallel load

An Application – Serial Addition

- Most operations in digital computers are done in parallel. Serial operations are slower but require less equipment.
- A serial adder is shown below. $A \leftarrow A + B$.

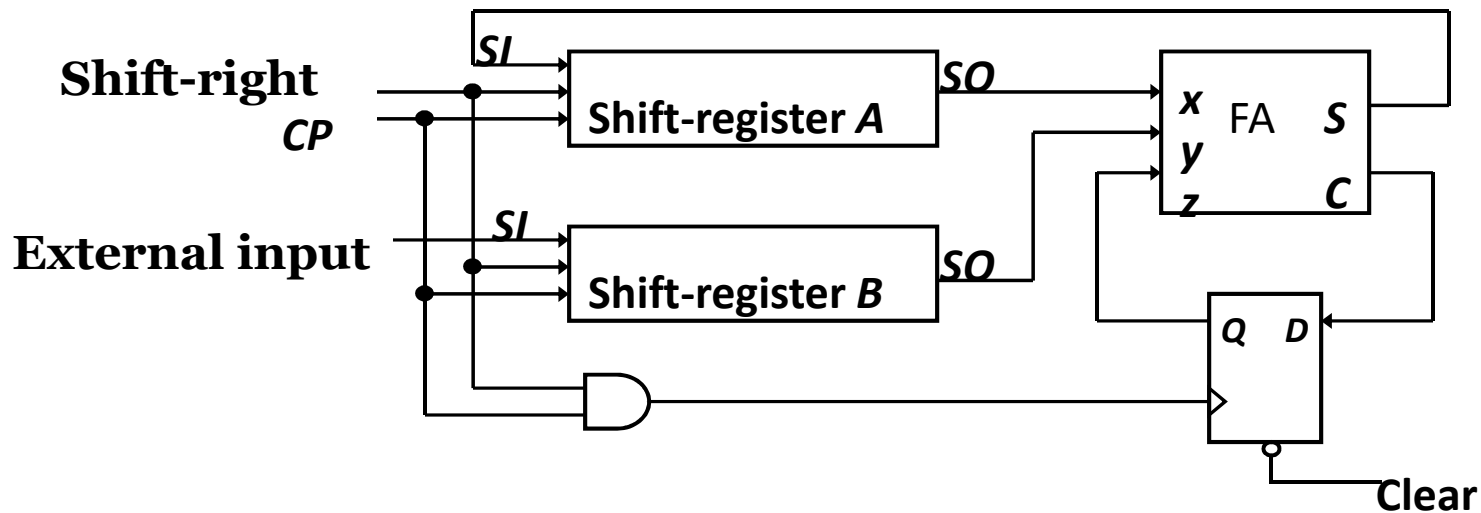

An Application – Serial Addition

- $A = 0100$; $B = 0111$. $A + B = 1011$ is stored in A after 4 clock pulses.

Initial:	A: 0 1 0 0	Q: 0
	B: 0 1 1 1	
<hr/>		
Step 1: 0 + 1 + 0	A: 1 0 1 0	Q: 0
S = 1, C = 0	B: x 0 1 1	
<hr/>		
Step 2: 0 + 1 + 0	A: 1 1 0 1	Q: 0
S = 1, C = 0	B: x x 0 1	
<hr/>		
Step 3: 1 + 1 + 0	A: 0 1 1 0	Q: 1
S = 0, C = 1	B: x x x 0	
<hr/>		
Step 4: 0 + 0 + 1	A: 1 0 1 1	Q: 0
S = 1, C = 0	B: x x x x	

Shift Register Counters

- **Shift register counter**: a shift register with the serial output connected back to the serial input.
- They are classified as counters because they give a specified sequence of states.
- Two common types: the *Johnson counter* and the *Ring counter*.

Ring Counters

- One flip-flop (stage) for each state in the sequence.
- The output of the last stage is connected to the D input of the first stage.
- An n -bit ring counter cycles through n states.
- No decoding gates are required, as there is an output that corresponds to every state the counter is in.

Ring Counters

- Example: A 6-bit (MOD-6) ring counter.

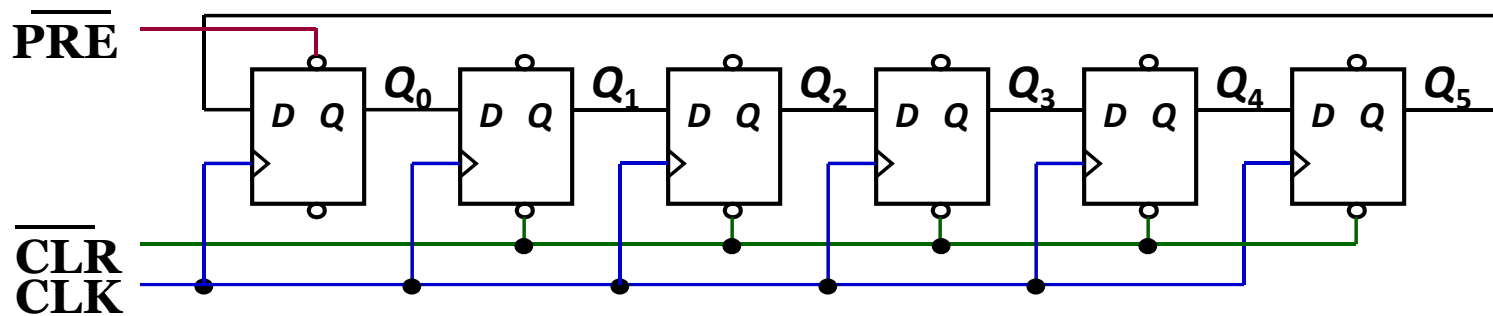

Clock	Q ₀	Q ₁	Q ₂	Q ₃	Q ₄	Q ₅
0	1	0	0	0	0	0
1	0	1	0	0	0	0
2	0	0	1	0	0	0
3	0	0	0	1	0	0
4	0	0	0	0	1	0
5	0	0	0	0	0	1

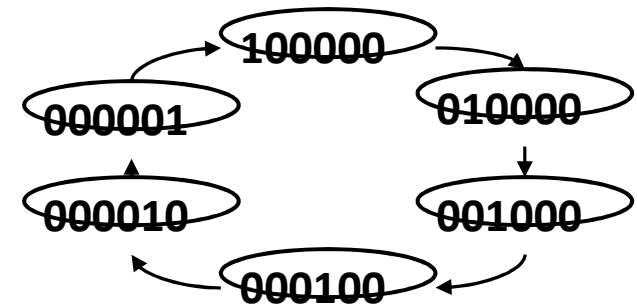

Johnson Counters

- The complement of the output of the last stage is connected back to the D input of the first stage.
- Also called the *twisted-ring counter*.
- Require fewer flip-flops than ring counters but more flip-flops than binary counters.
- An n -bit Johnson counter cycles through $2n$ states.
- Require more decoding circuitry than ring counter but less than binary counters.

Cont...

- Example: A 4-bit (MOD-8) Johnson counter.

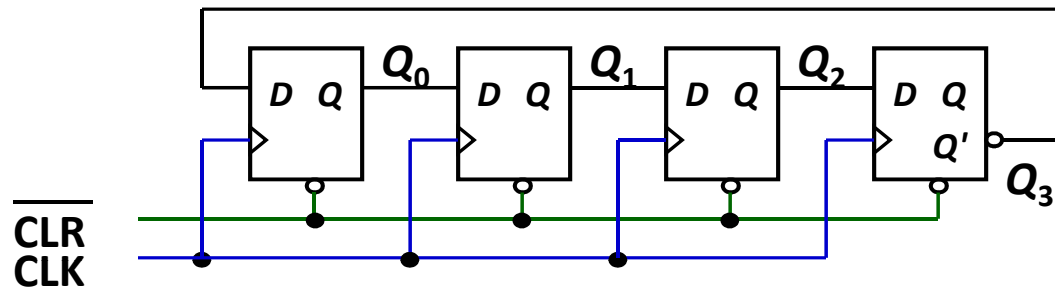

Clock	Q_0	Q_1	Q_2	Q_3
0	0	0	0	0
1	1	0	0	0
2	1	1	0	0
3	1	1	1	0
4	1	1	1	1
5	0	1	1	1
6	0	0	1	1
7	0	0	0	1

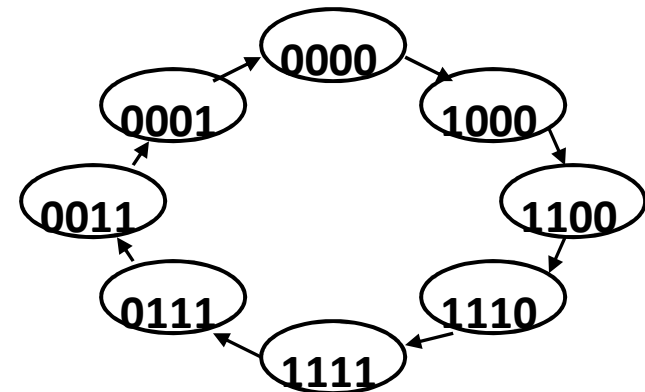

Cont...

- Decoding logic for a 4-bit Johnson counter.

Clock	A	B	C	D	Decoding
0	0	0	0	0	$A'.D'$
1	1	0	0	0	$A.B'$
2	1	1	0	0	$B.C'$
3	1	1	1	0	$C.D'$
4	1	1	1	1	$A.D$
5	0	1	1	1	$A'.B$
6	0	0	1	1	$B'.C$
7	0	0	0	1	$C'.D$

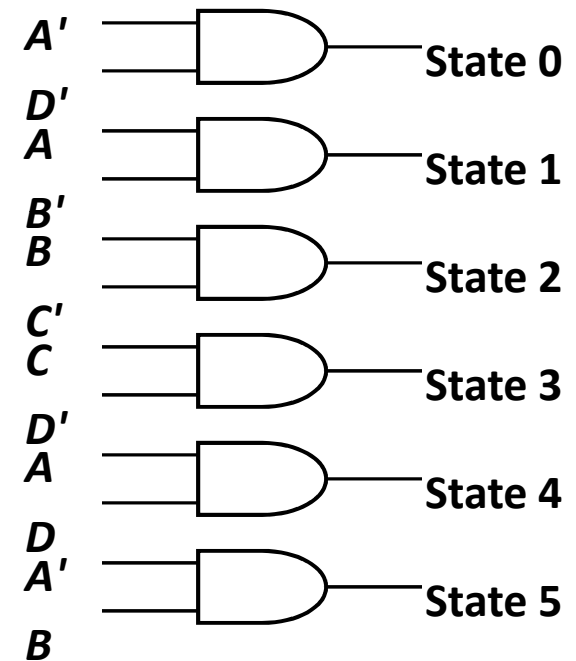
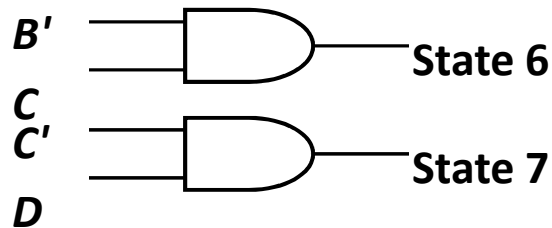

THANK YOU