

THREE PHASE CIRCUIT

Objectives

- Explain the differences between single-phase, two-phase and three-phase.
- Compute and define the **Balanced Three-Phase** voltages.
- Determine the phase and line voltages/currents for Three-Phase systems.

SINGLE PHASE TWO WIRE

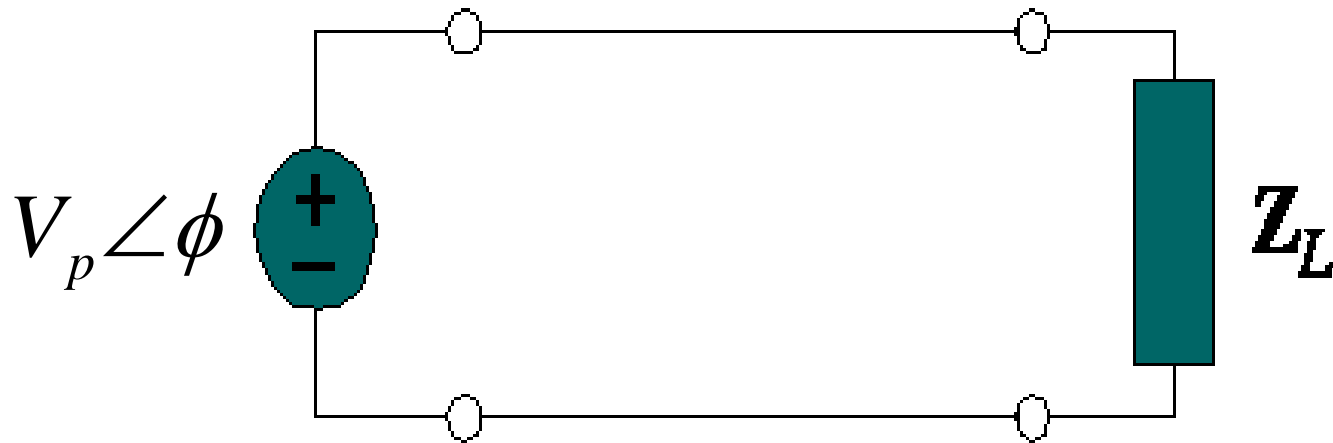

SINGLE PHASE SYSTEM

- A generator connected through a pair of wire to a load – **Single Phase Two Wire.**
- V_p is the magnitude of the source voltage, and ϕ is the phase.

SINLGE PHASE THREE WIRE

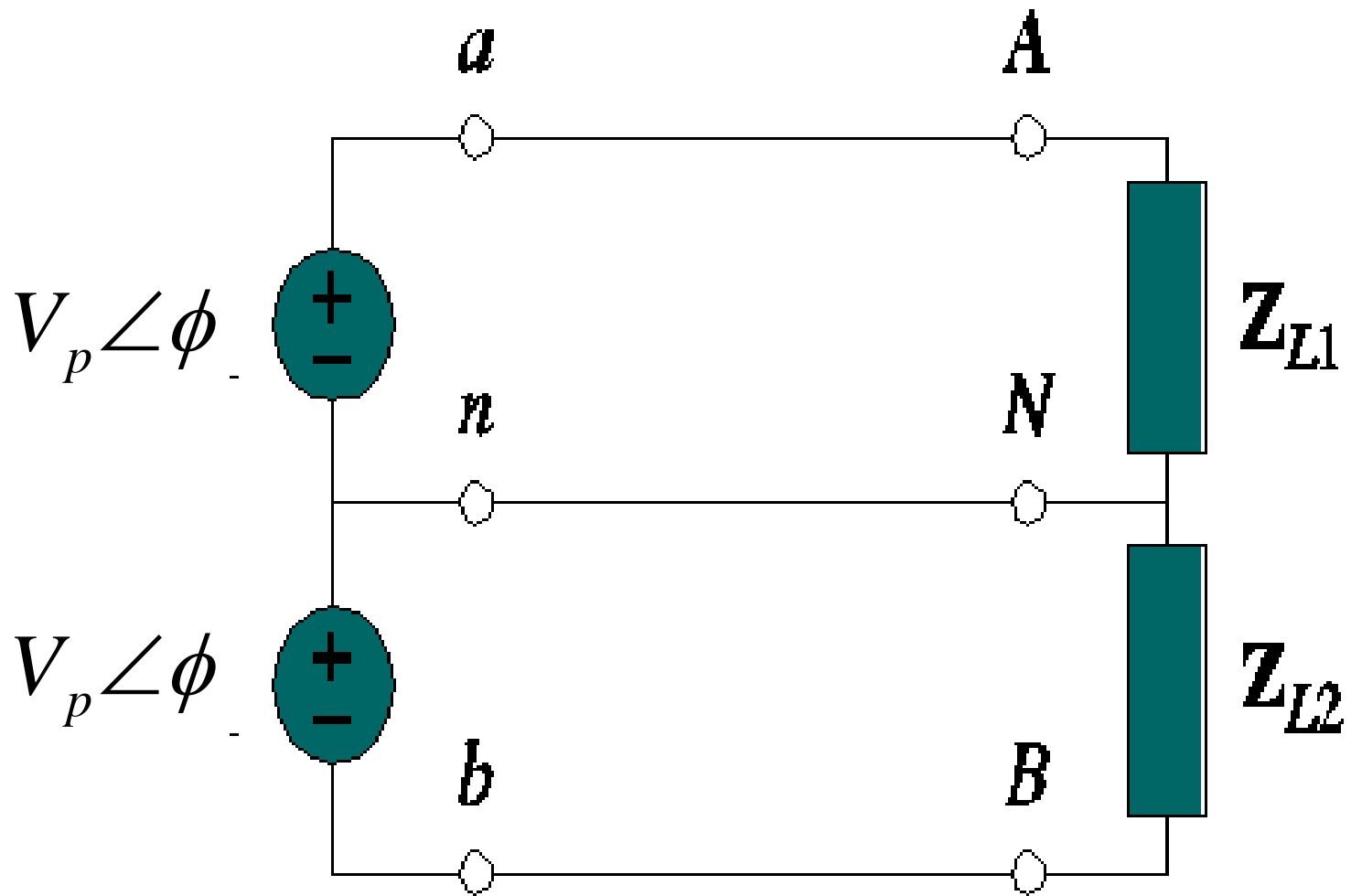

SINGLE PHASE SYSTEM

- Most common in practice: two identical sources connected to two loads by two outer wires and the neutral: **Single Phase Three Wire**.
- Terminal voltages have same magnitude and the same phase.

POLYPHASE SYSTEM

- Circuit or system in which AC sources operate at the same frequency but different phases are known as polyphase.

TWO PHASE SYSTEM THREE WIRE

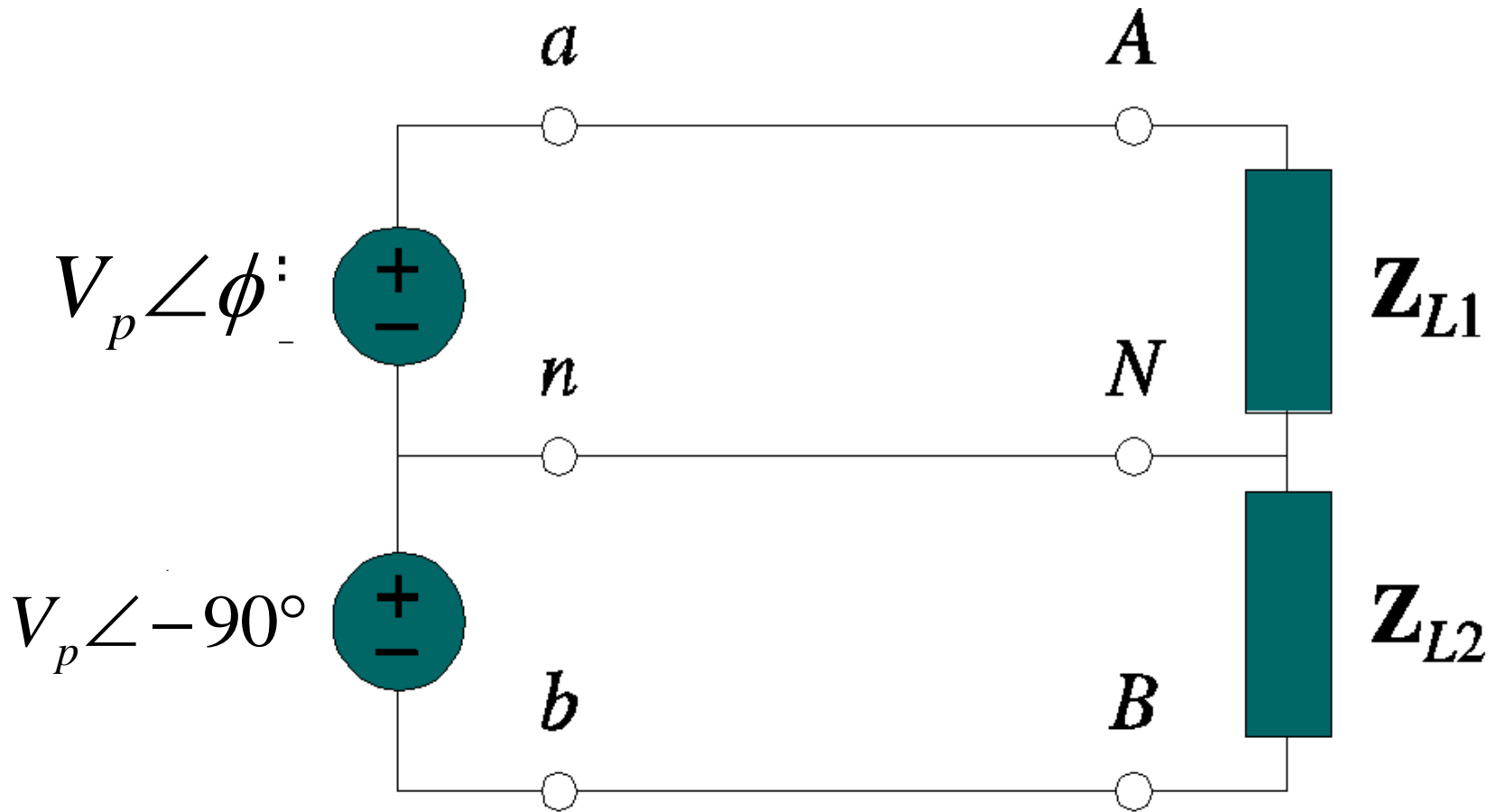

POLYPHASE SYSTEM

- **Two Phase System:**
 - A generator consists of two coils placed perpendicular to each other
 - The voltage generated by one lags the other by 90° .

POLYPHASE SYSTEM

- **Three Phase System:**
 - A generator consists of three coils placed 120° apart.
 - The voltage generated are equal in magnitude but, out of phase by 120° .
- Three phase is the most economical polyphase system.

THREE PHASE FOUR WIRE

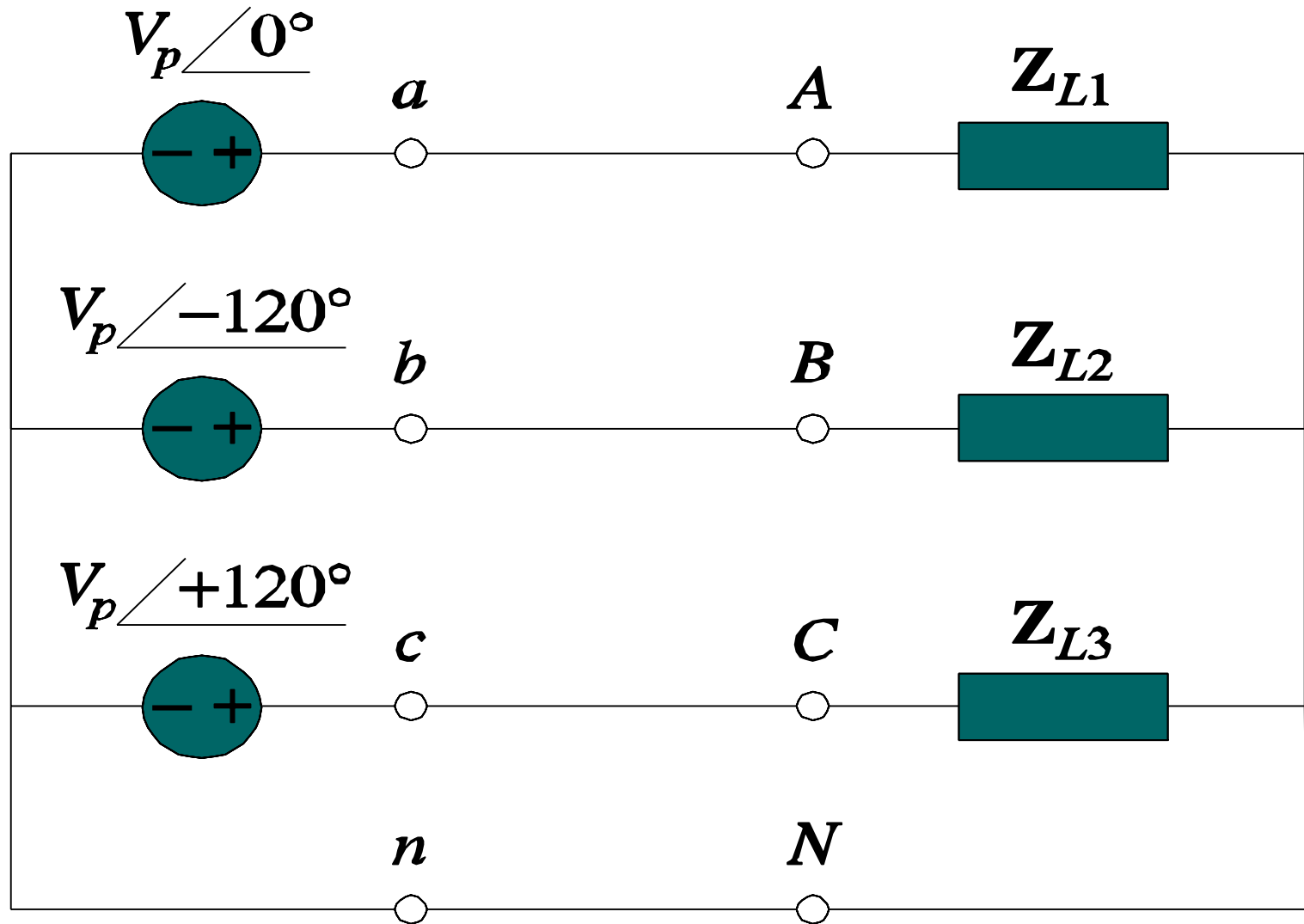

IMPORTANCE OF THREE PHASE SYSTEM

- All electric power is generated and distributed in three phase.
 - One phase, two phase, or more than three phase input can be taken from three phase system rather than generated independently.
 - Melting purposes need 48 phases supply.

IMPORTANCE OF THREE PHASE SYSTEM

- Uniform power transmission and less vibration of three phase machines.
 - The instantaneous power in a 3ϕ system can be constant (not pulsating).
 - High power motors prefer a steady torque especially one created by a rotating magnetic field.

IMPORTANCE OF THREE PHASE SYSTEM

- Three phase system is more economical than the single phase.
 - The amount of wire required for a three phase system is less than required for an equivalent single phase system.
 - Conductor: Copper, Aluminum, etc

THREE PHASE GENERATION

FARADAYS LAW

- Three things must be present in order to produce electrical current:
 - a) Magnetic field
 - b) Conductor
 - c) Relative motion
- Conductor cuts lines of magnetic flux, a voltage is induced in the conductor
- Direction and Speed are important

GENERATING A SINGLE PHASE

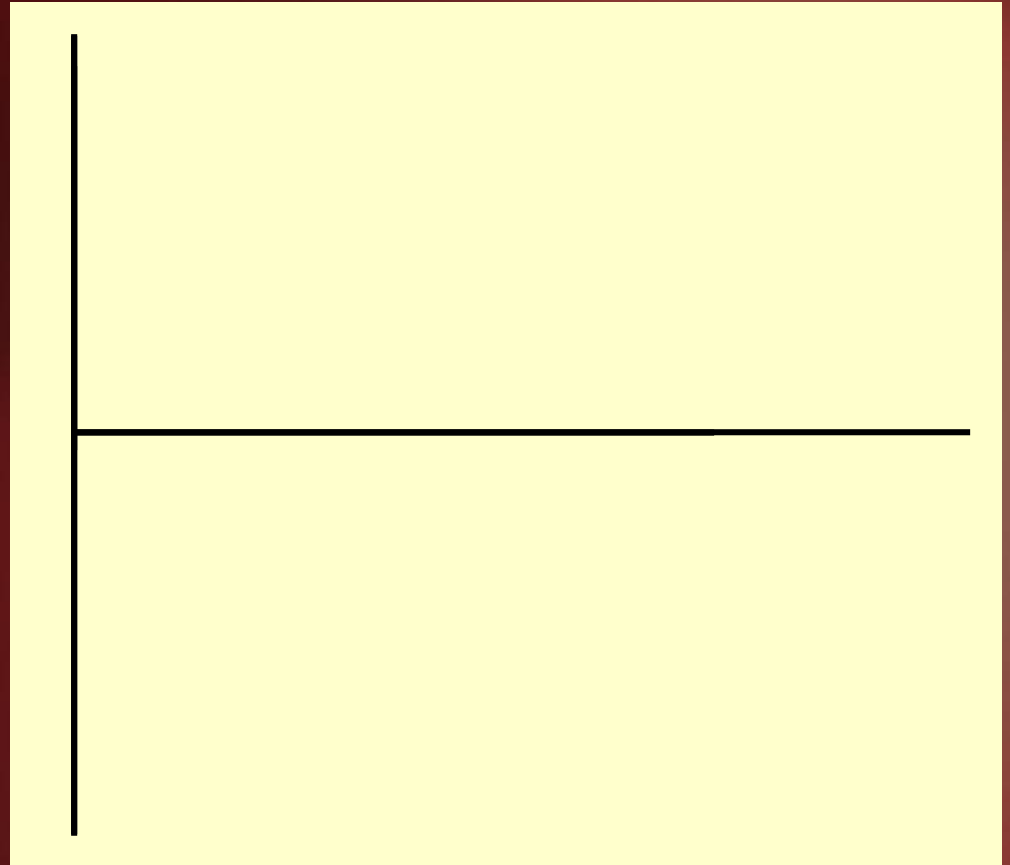
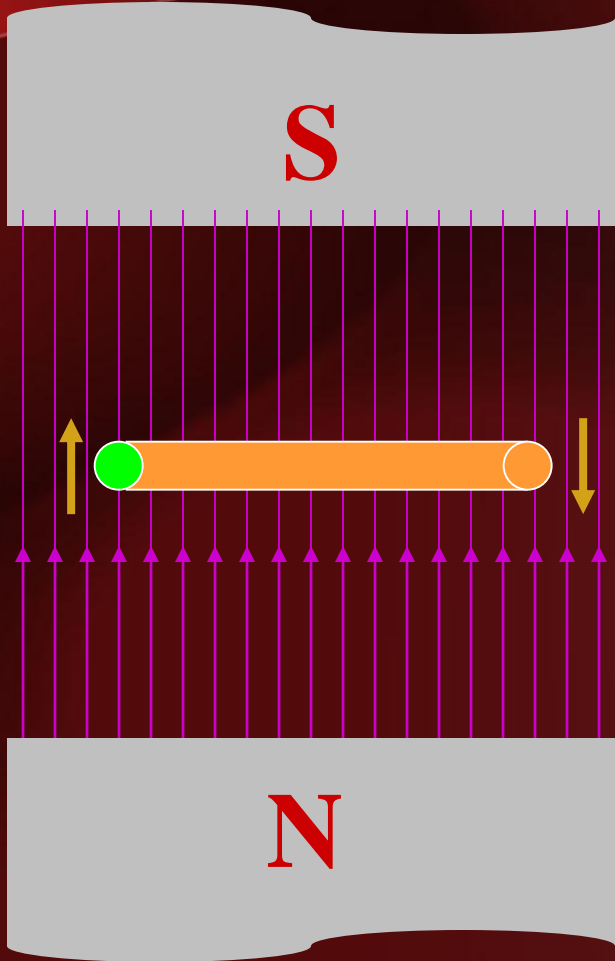

Motion is parallel to the flux.

No voltage is induced.

GENERATING A SINGLE PHASE

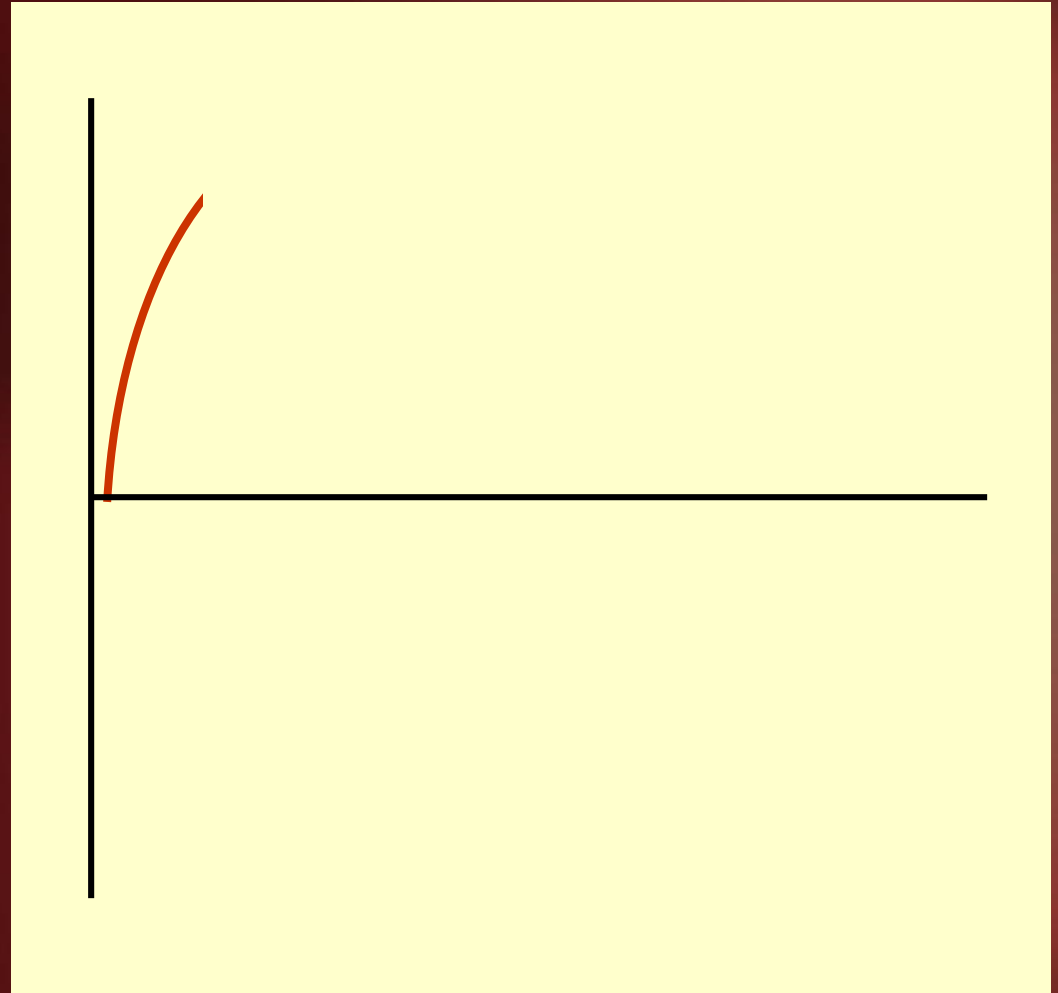
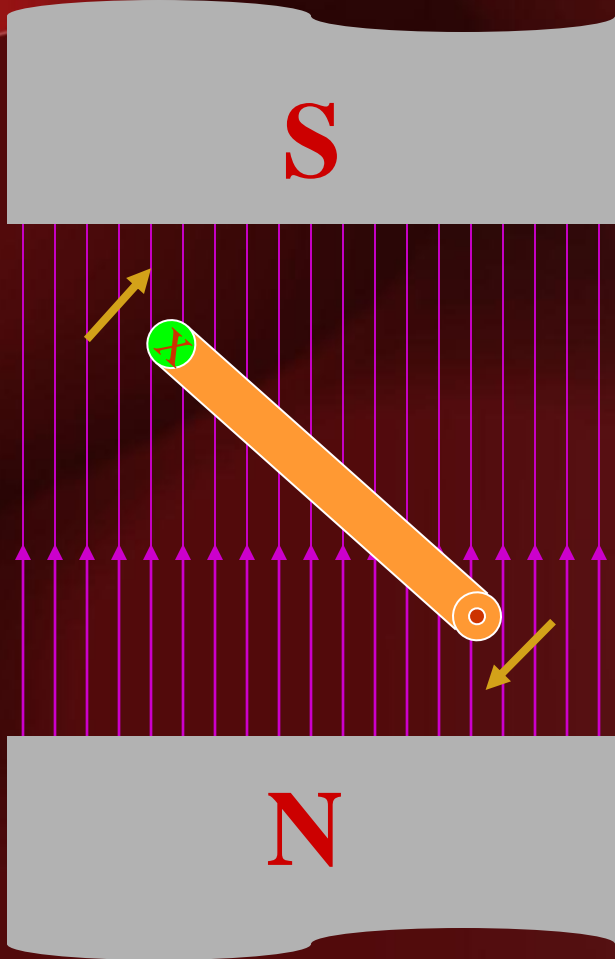

Motion is 45° to flux.
Induced voltage is 0.707 of maximum.

GENERATING A SINGLE PHASE

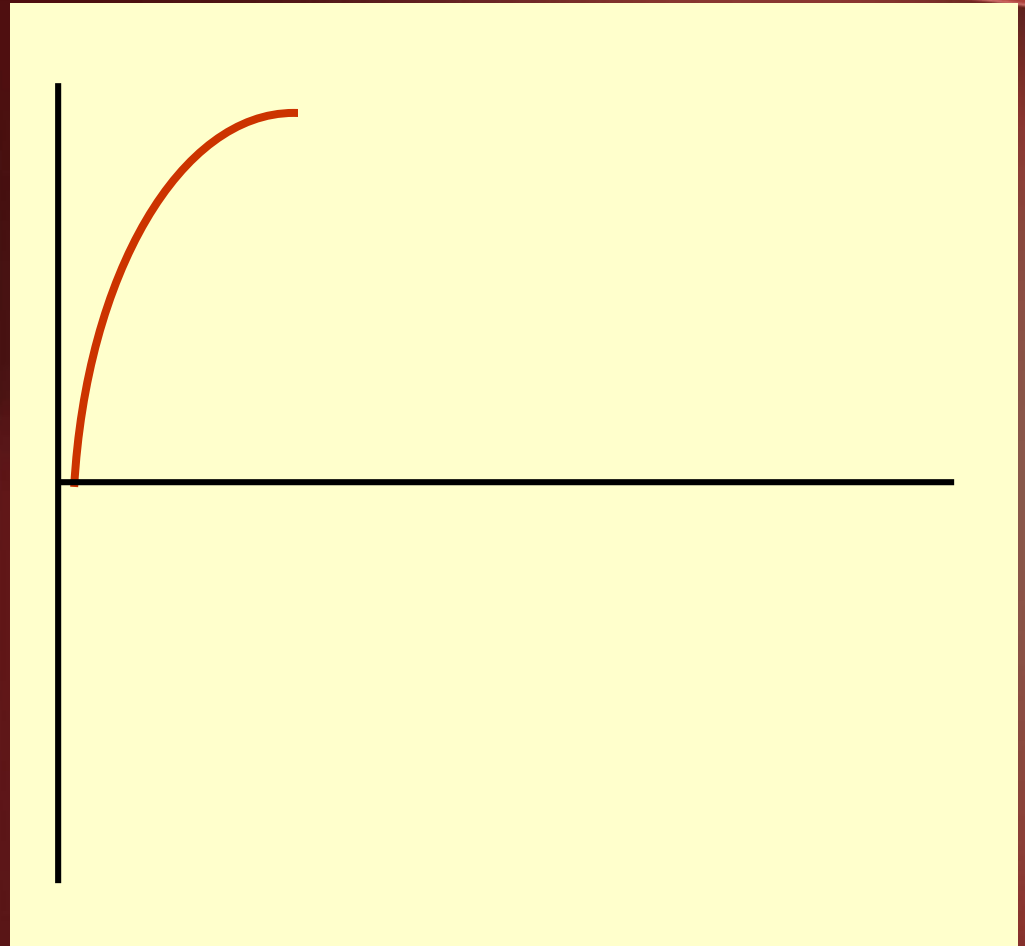
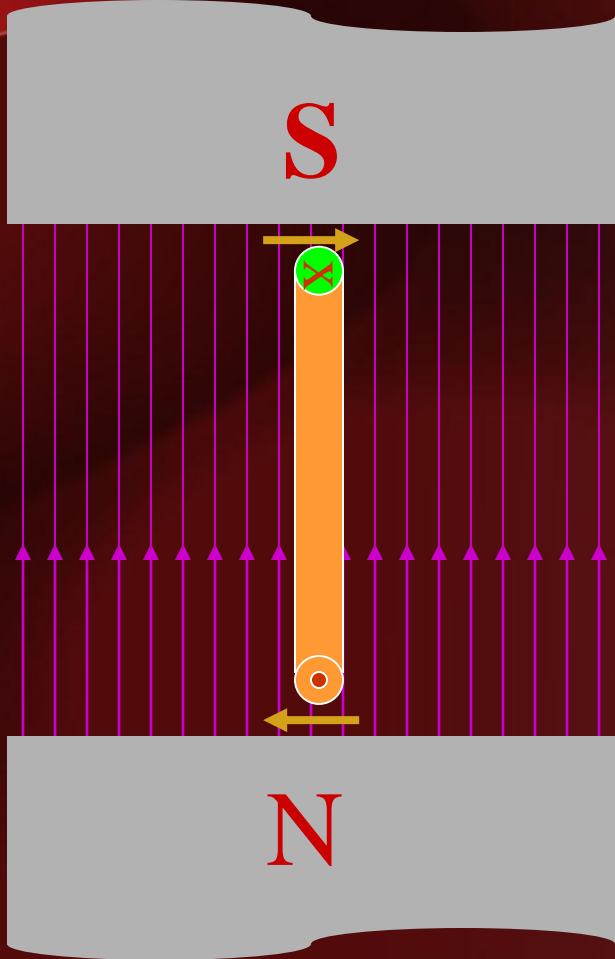

Motion is perpendicular to flux.
Induced voltage is maximum.

GENERATING A SINGLE PHASE

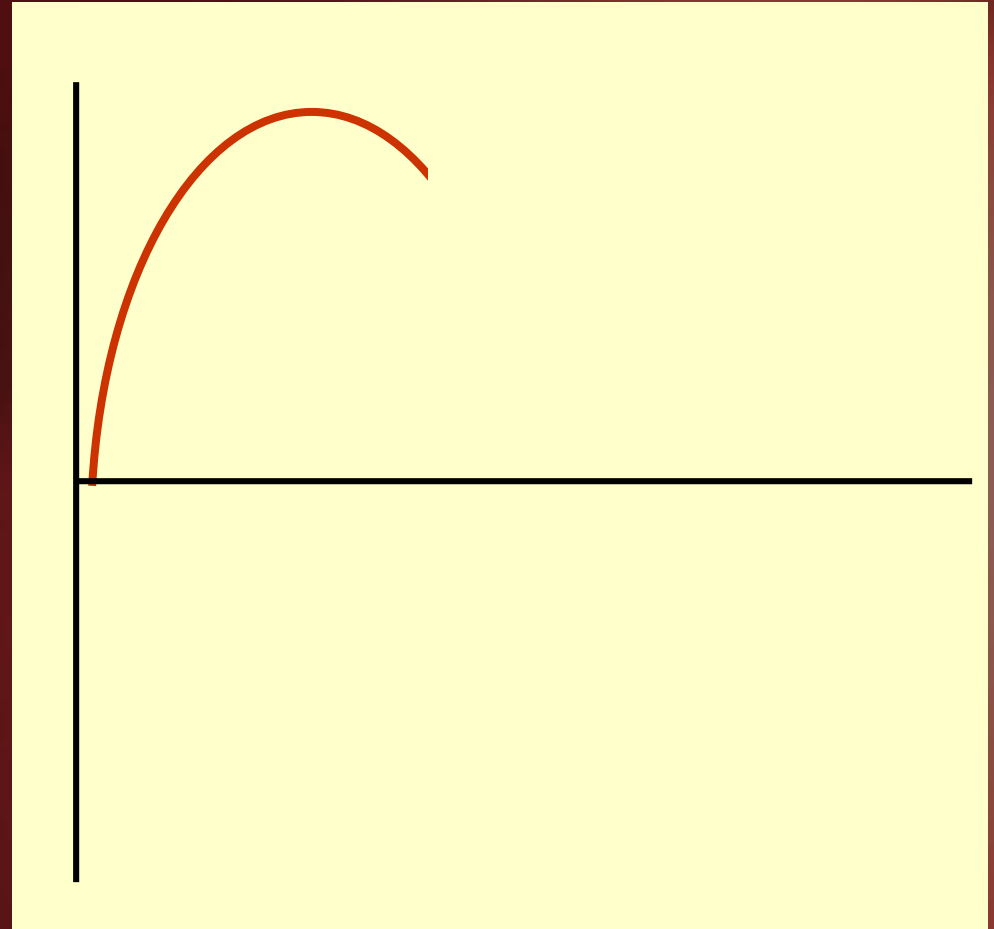
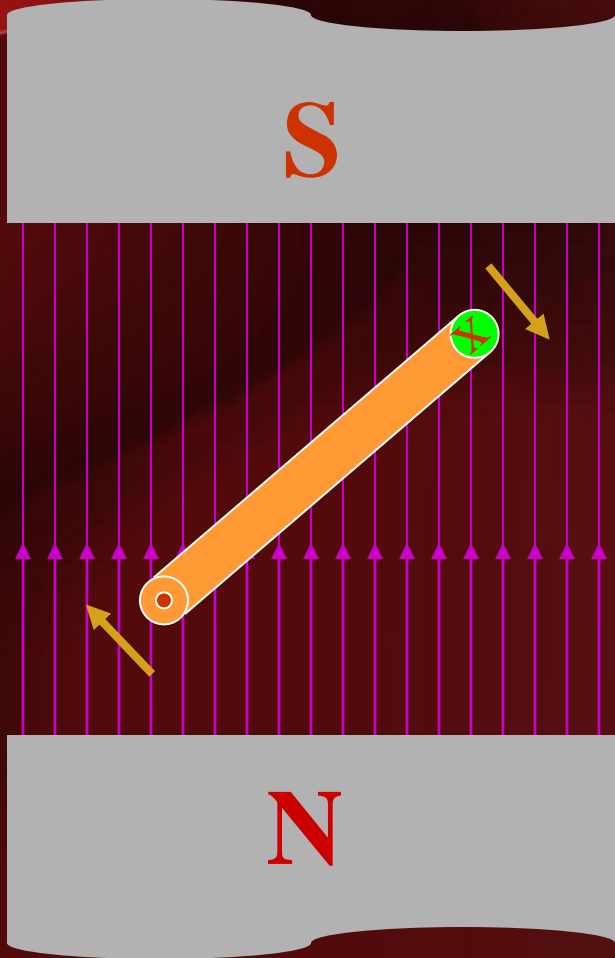

Motion is 45° to flux.

Induced voltage is 0.707 of maximum.

GENERATING A SINGLE PHASE

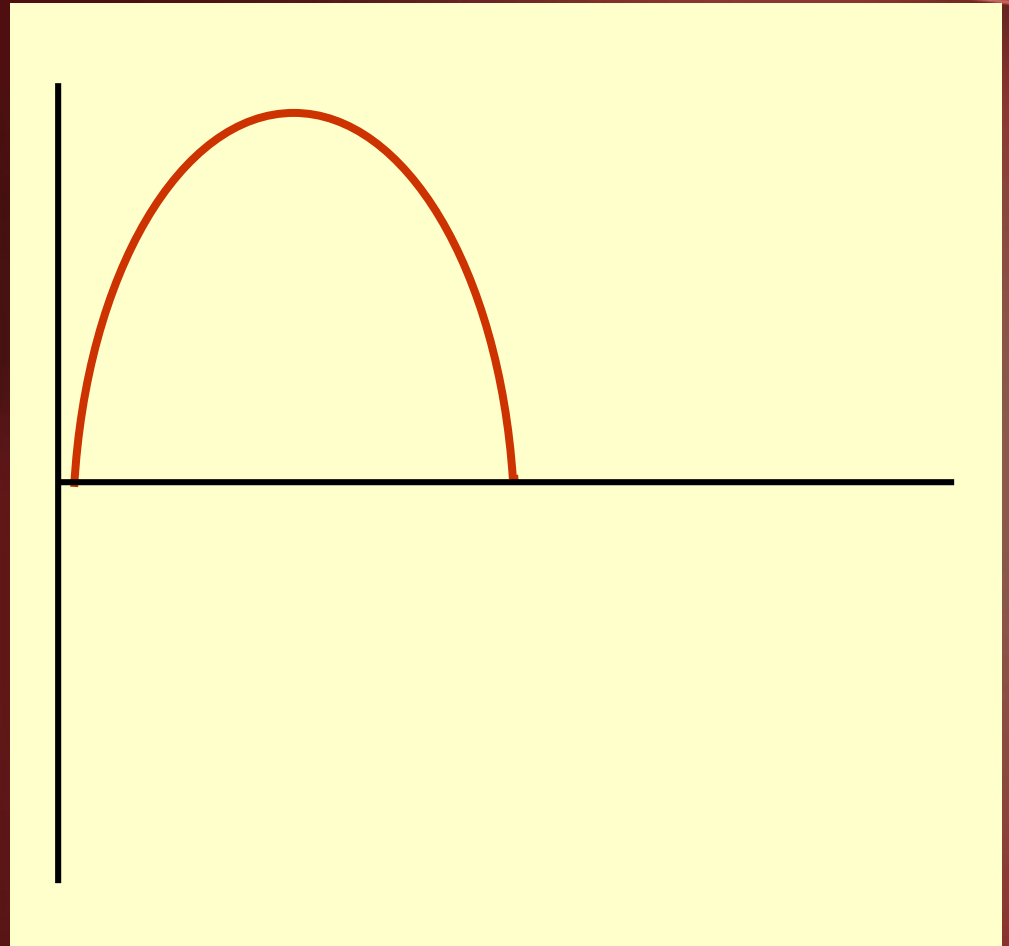
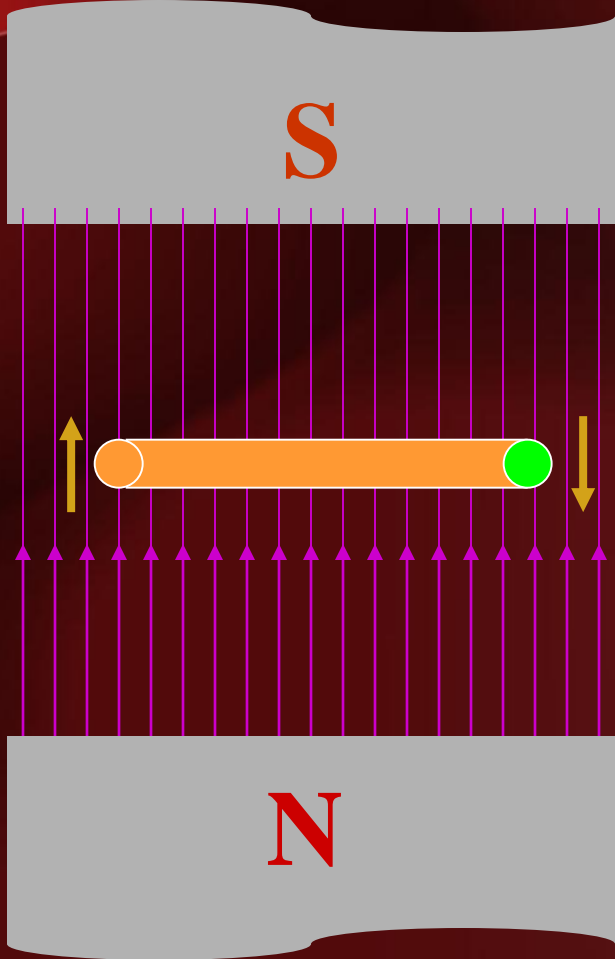

Motion is parallel to flux.

No voltage is induced.

GENERATING A SINGLE PHASE

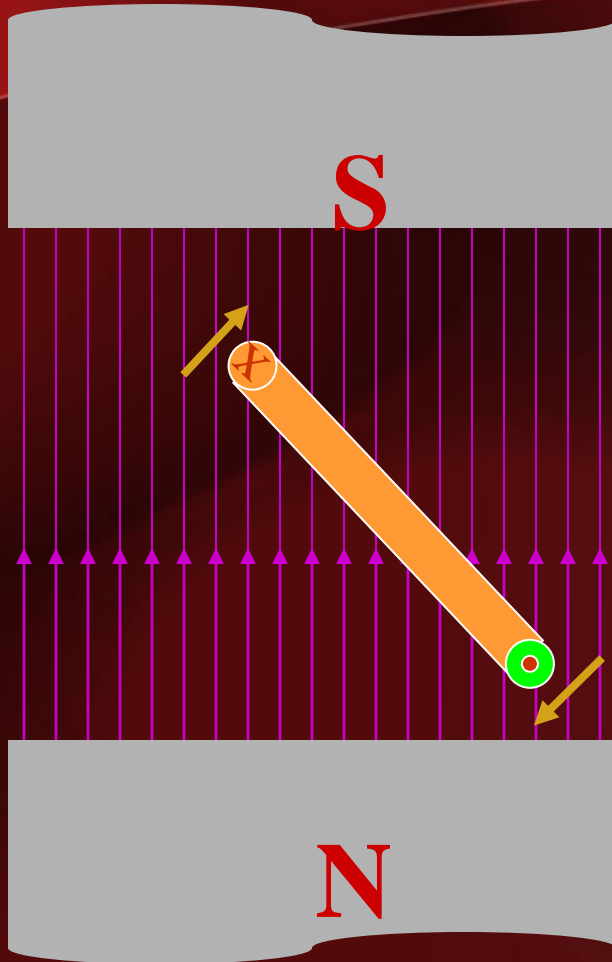

Notice current in the conductor has reversed.

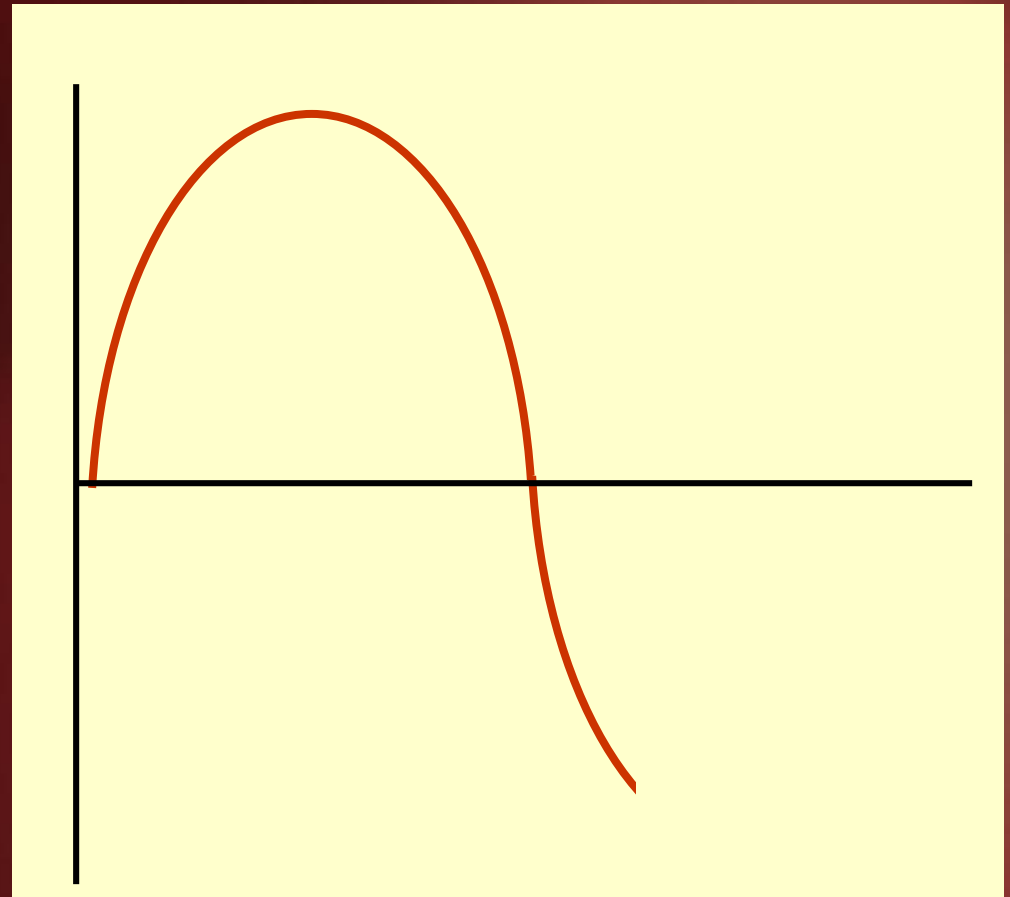

Motion is 45° to flux.
Induced voltage is 0.707 of maximum.

GENERATING A SINGLE PHASE

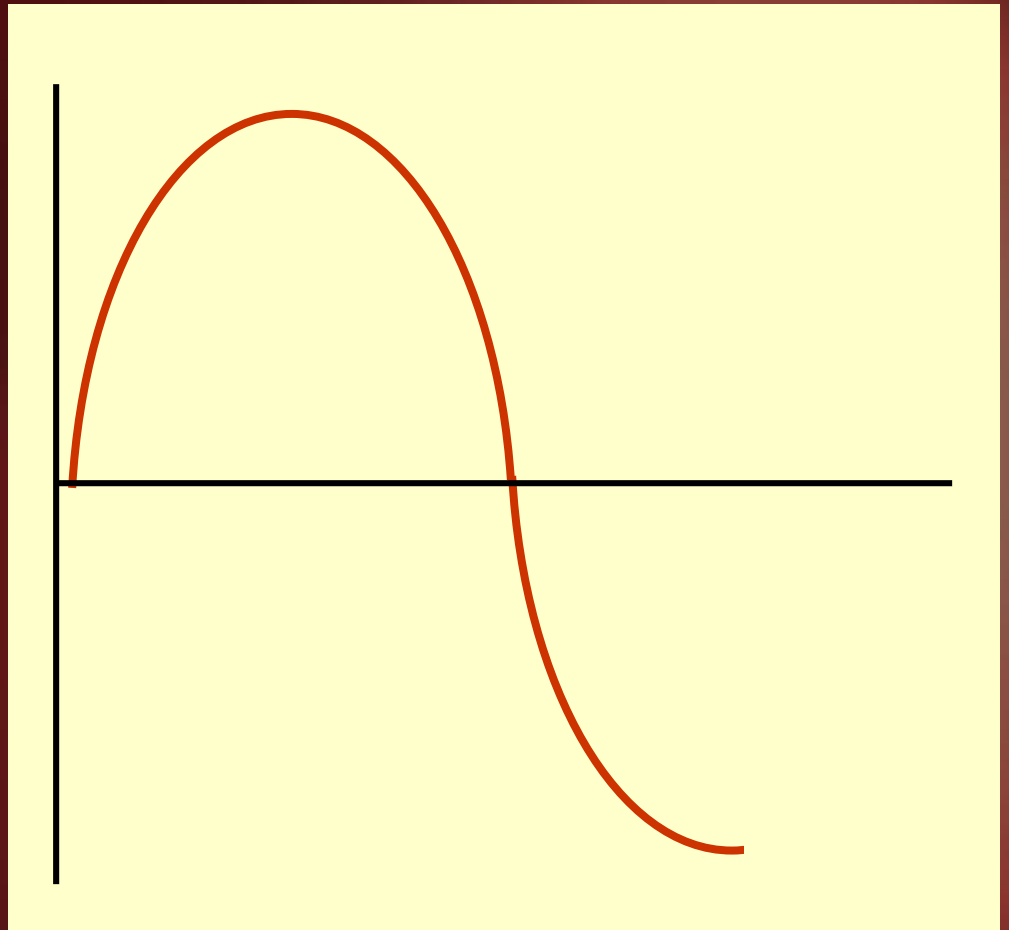
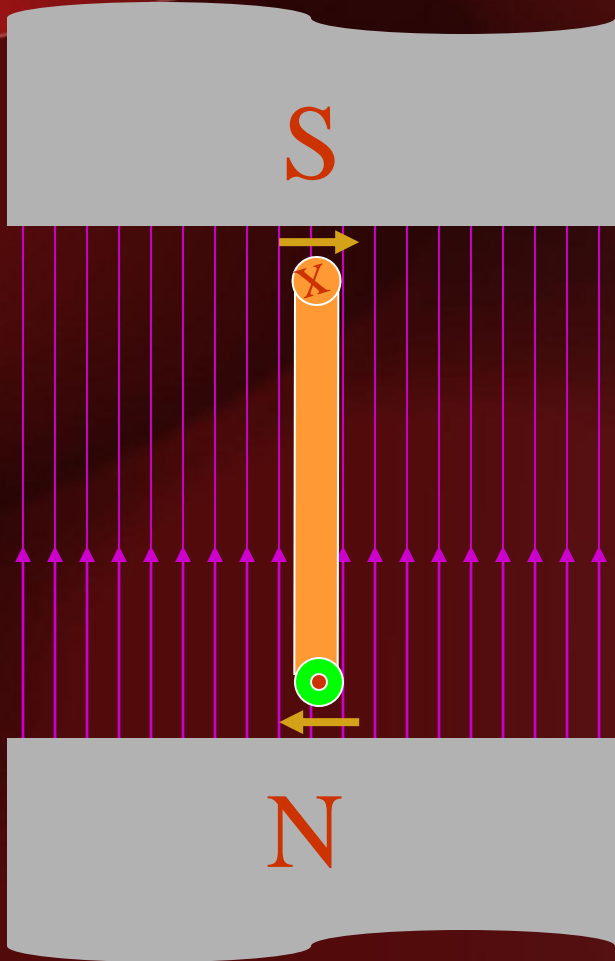

Motion is perpendicular to flux.

Induced voltage is maximum.

GENERATING A SINGLE PHASE

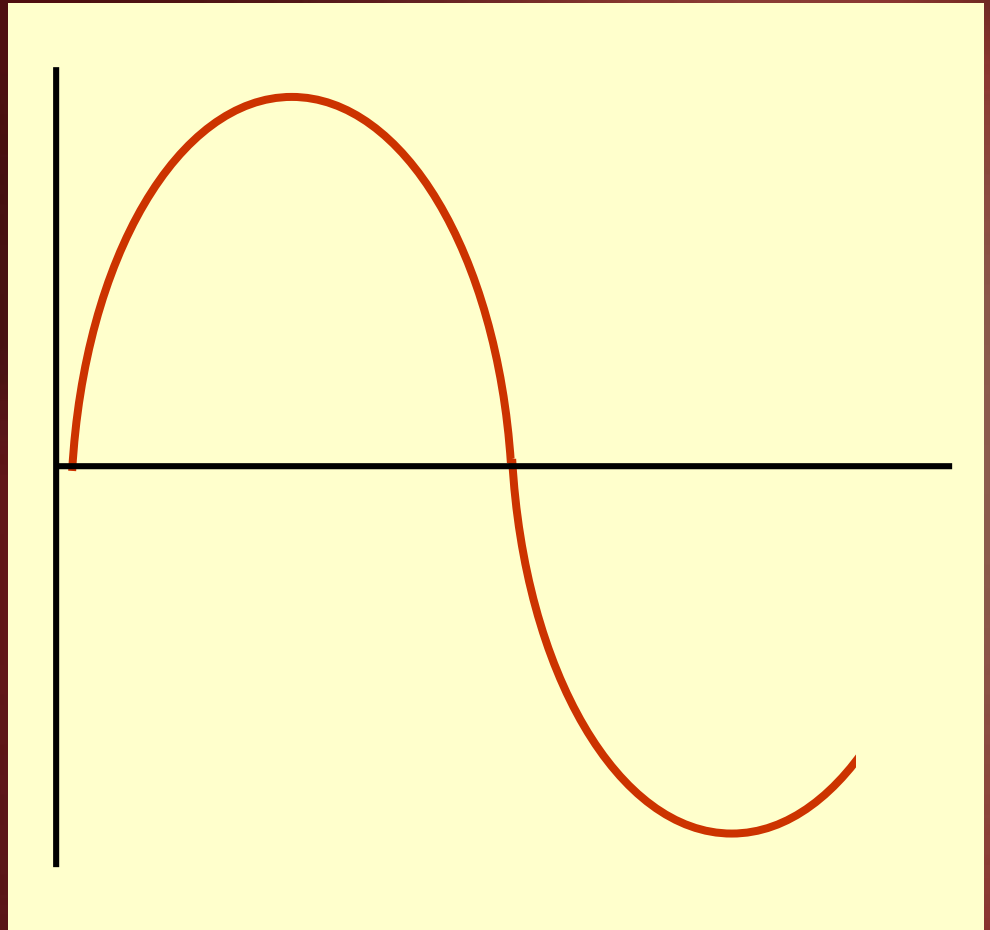
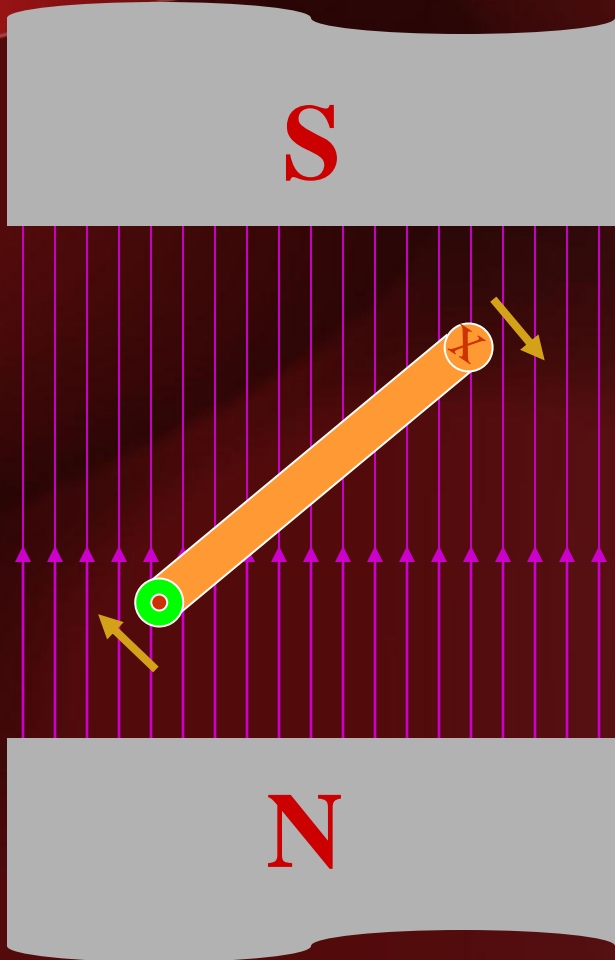

Motion is 45° to flux.

Induced voltage is 0.707 of maximum.

GENERATING A SINGLE PHASE

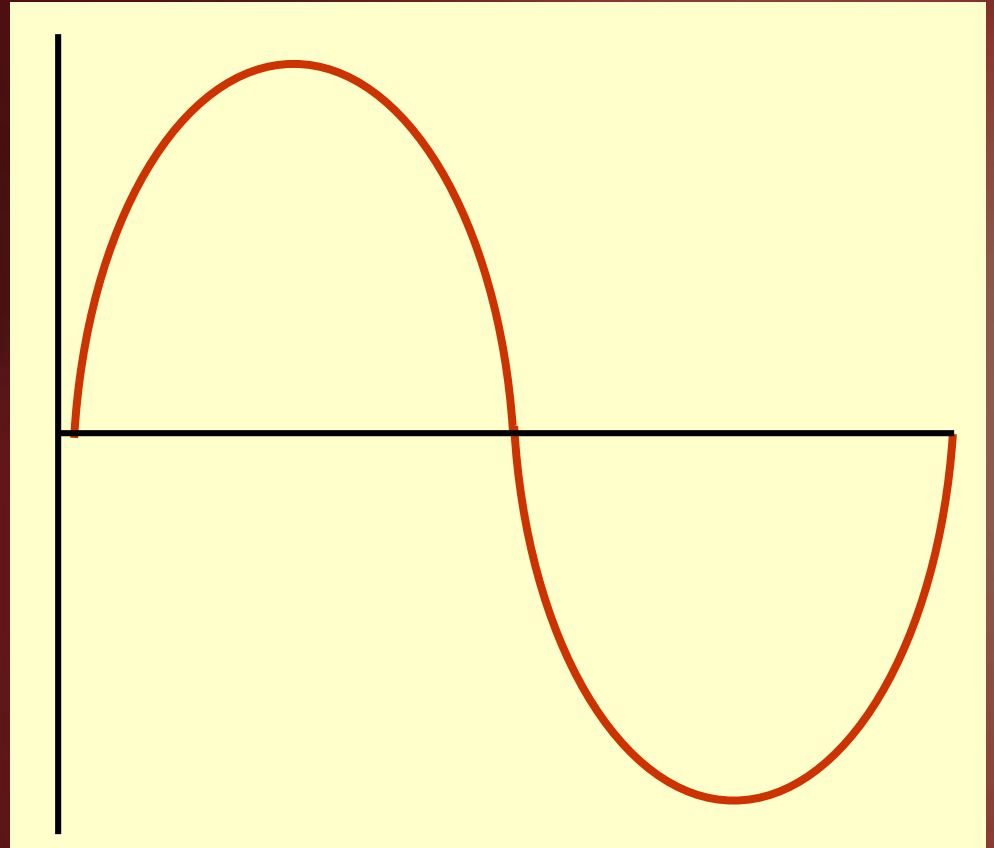
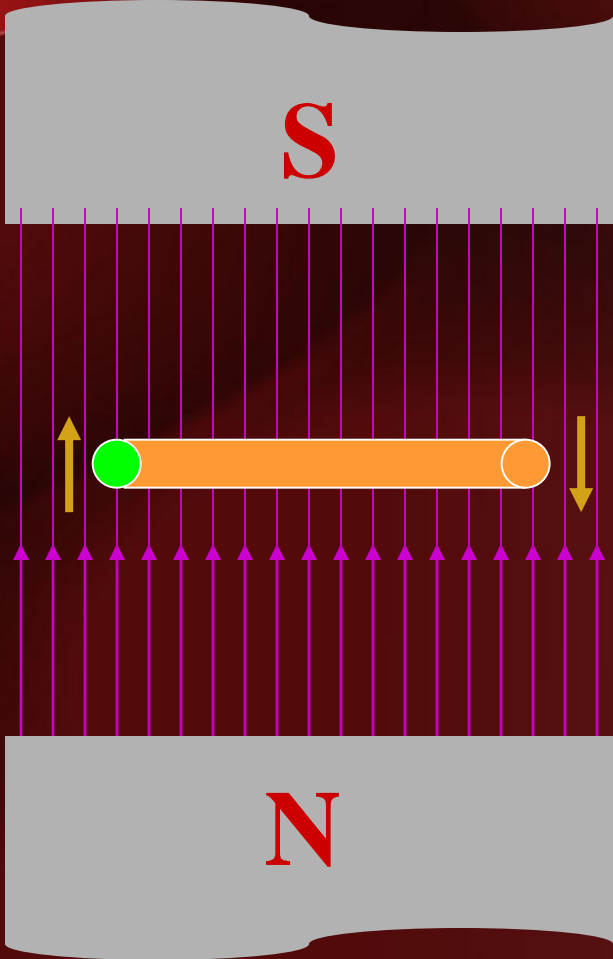

Motion is parallel to flux.

No voltage is induced.

Ready to produce another cycle.

THREE PHASE GENERATOR

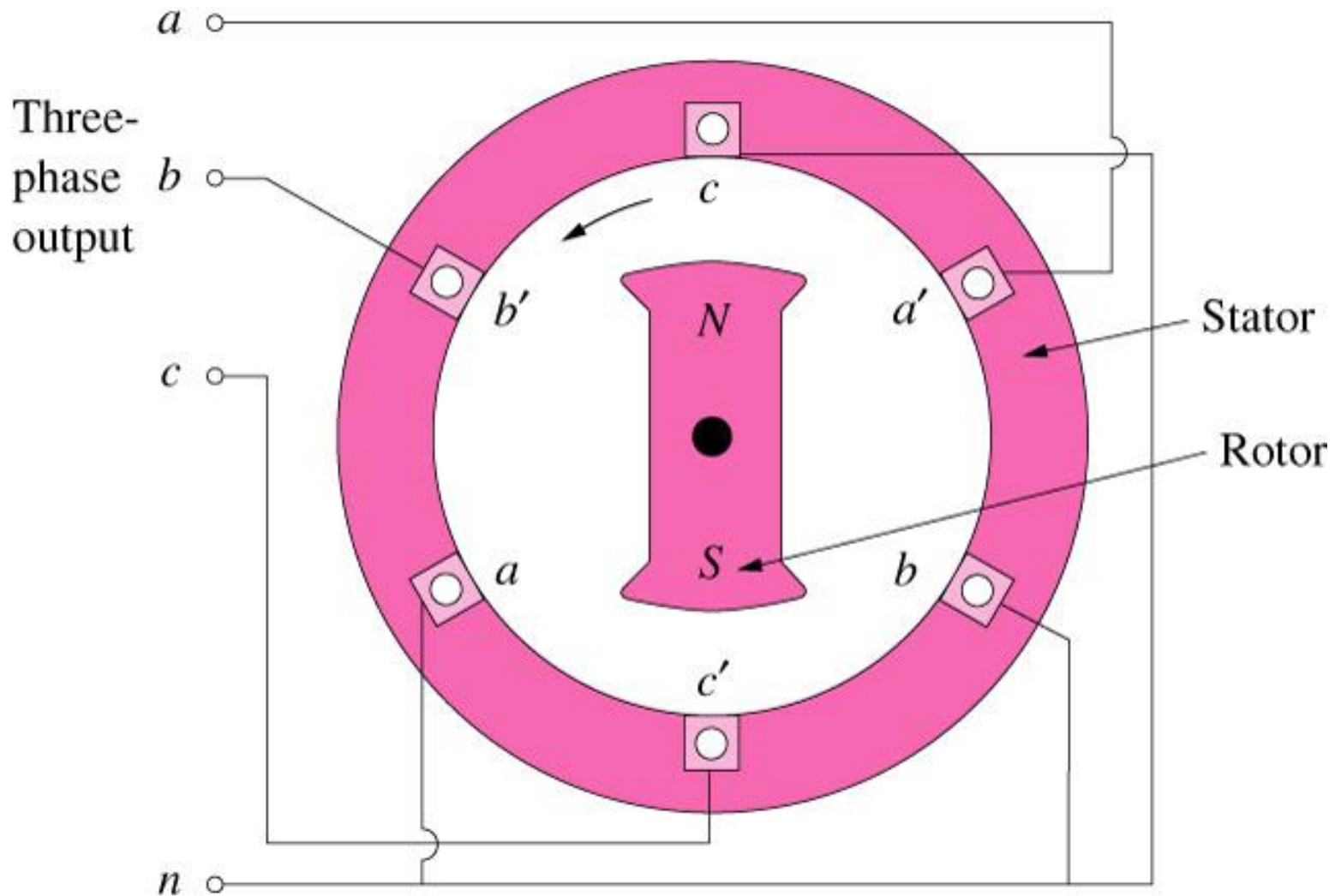

GENERATOR WORK

- The generator consists of a rotating magnet (**rotor**) surrounded by a stationary winding (**stator**).
- Three separate windings or coils with terminals a-a', b-b', and c-c' are physically placed 120° apart around the stator.

- As the rotor rotates, its magnetic field cuts the flux from the three coils and induces voltages in the coils.
- The induced voltage have equal magnitude but out of phase by 120° .

GENERATION OF THREE-PHASE AC

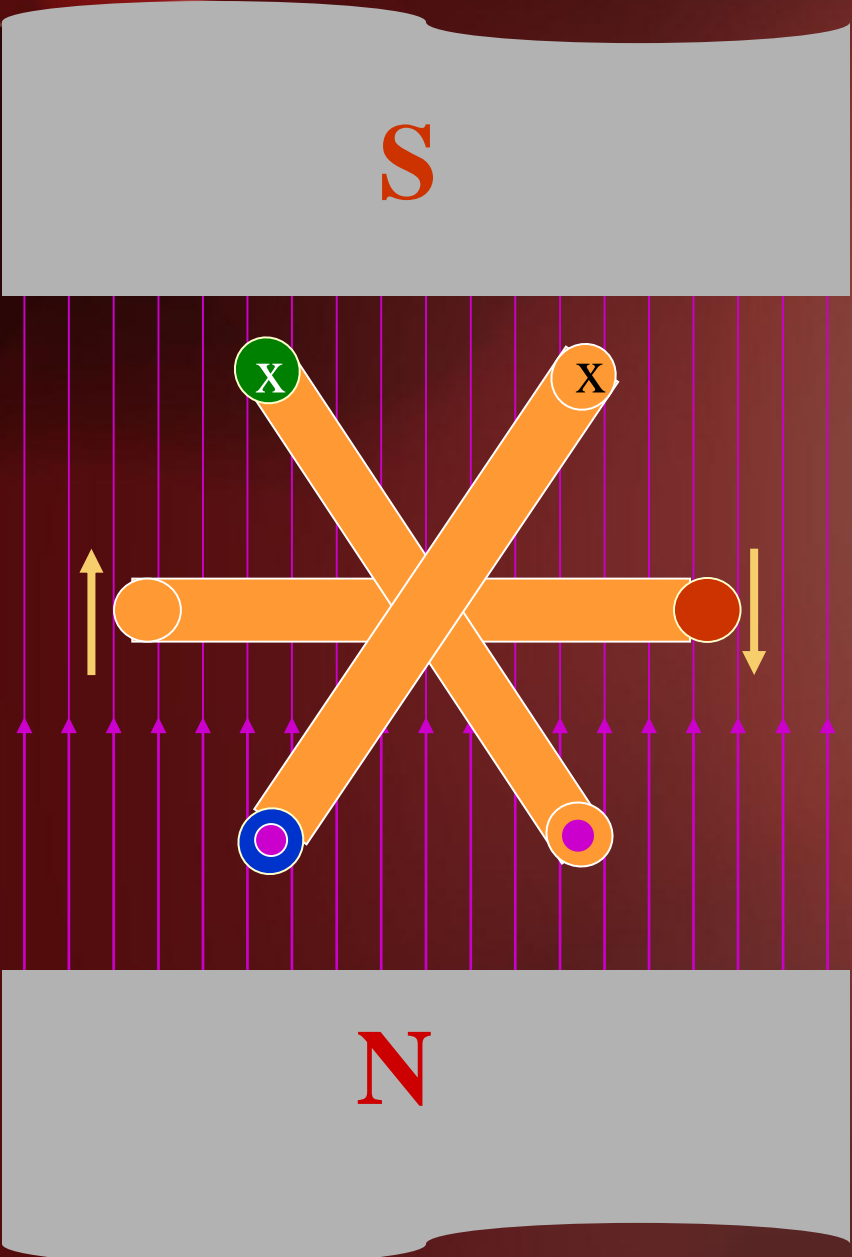

THREE-PHASE WAVEFORM

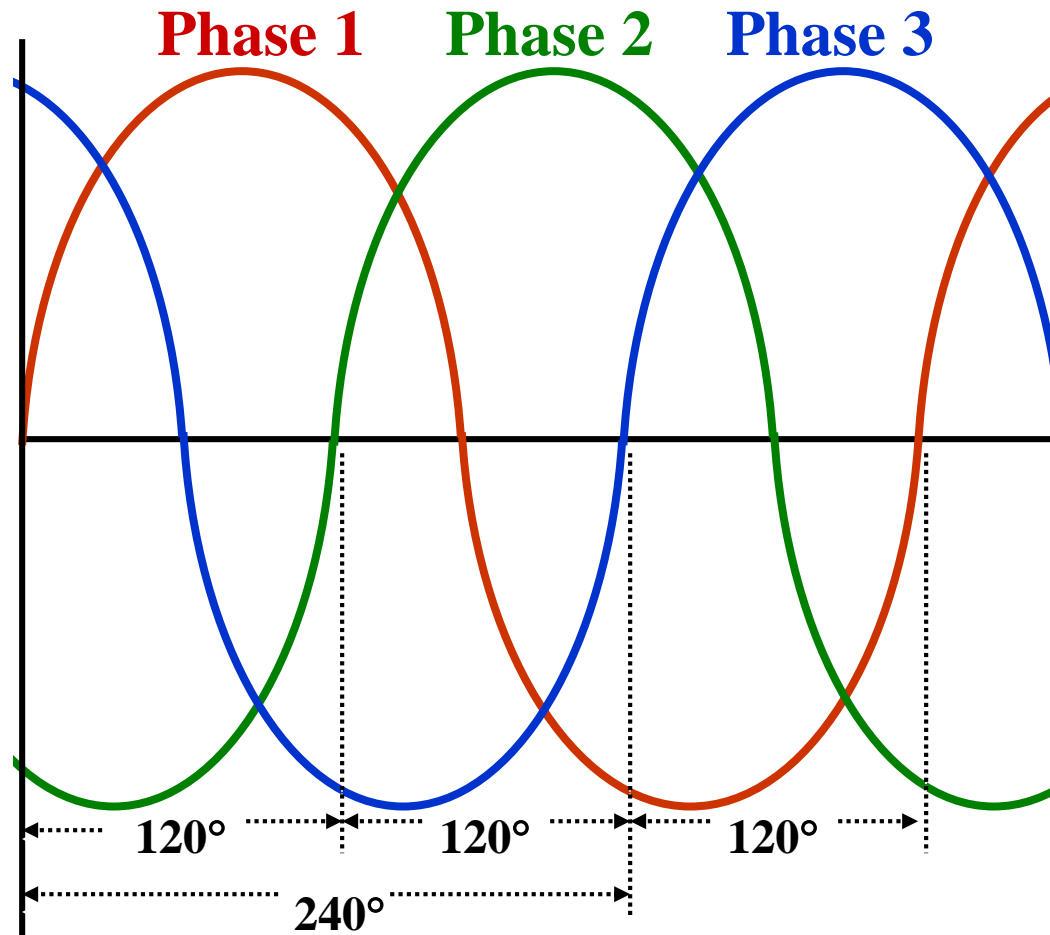

Phase 2 lags **phase 1** by 120° .

Phase 3 lags **phase 1** by 240° .

Phase 2 leads **phase 3** by 120° .

Phase 1 leads **phase 3** by 240° .

GENERATION OF 3 ϕ VOLTAGES

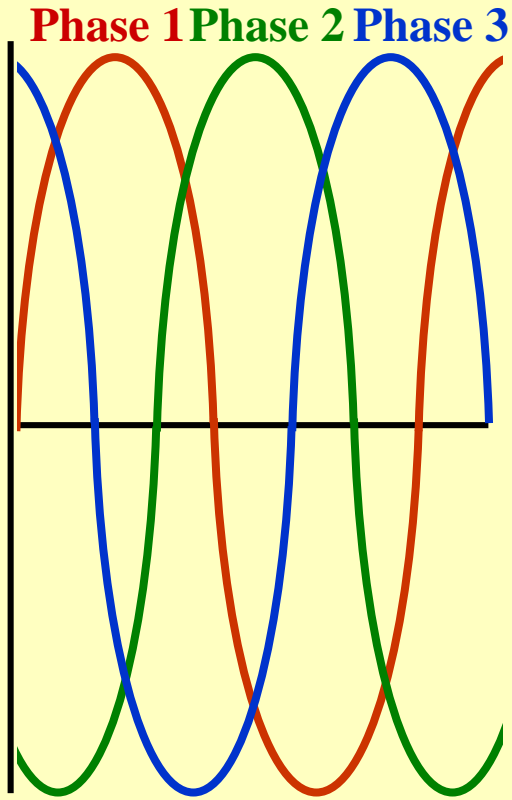

Phase 1 is ready to go positive.
Phase 2 is going more negative.
Phase 3 is going less positive.

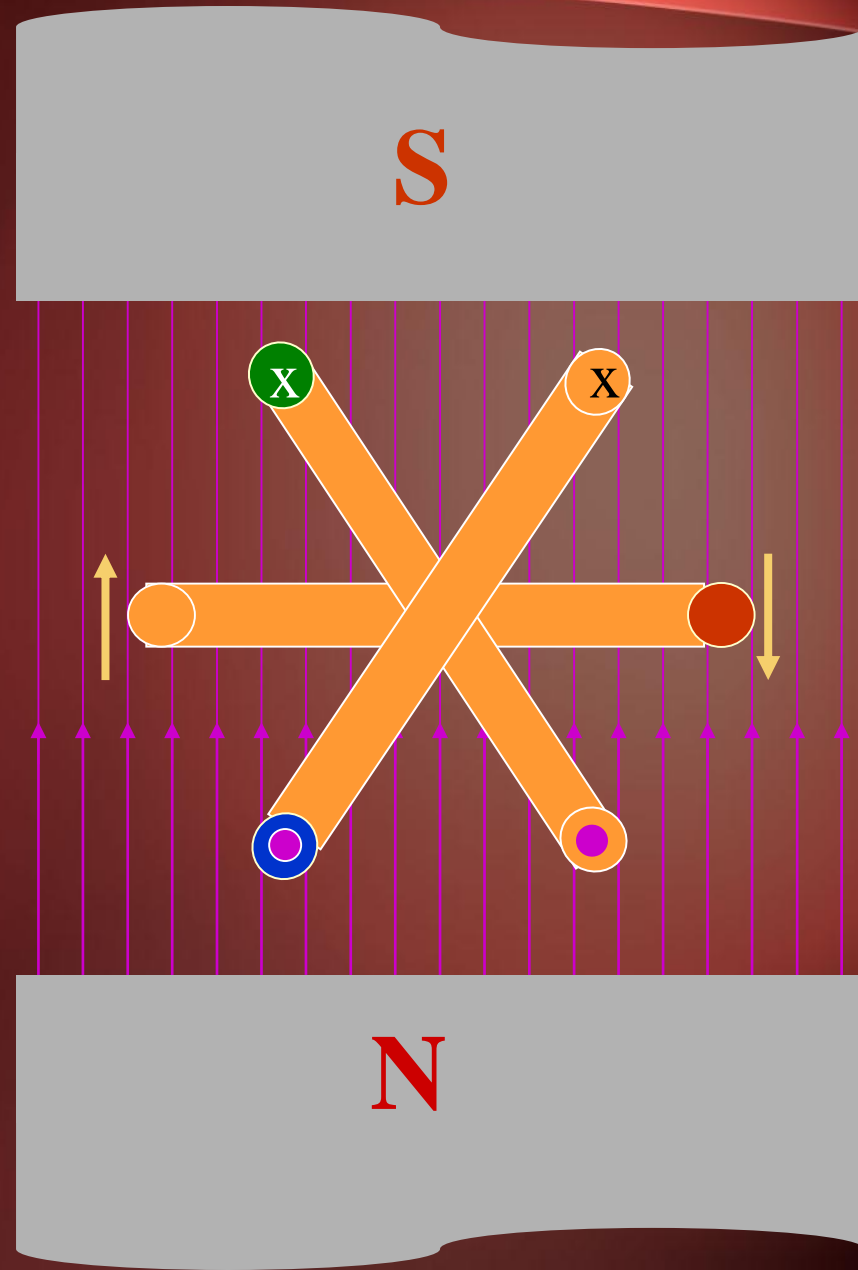

THREE PHASE QUANTITIES

BALANCED 3 ϕ VOLTAGES

- Balanced three phase voltages:
 - same magnitude (V_M)
 - 120° phase shift

$$v_{an}(t) = V_M \cos(\omega t)$$

$$v_{bn}(t) = V_M \cos(\omega t - 120^\circ)$$

$$v_{cn}(t) = V_M \cos(\omega t - 240^\circ) = V_M \cos(\omega t + 120^\circ)$$

BALANCED 3 ϕ CURRENTS

- Balanced three phase currents:
 - same magnitude (I_M)
 - 120° phase shift

$$i_a(t) = I_M \cos(\omega t - \theta)$$

$$i_b(t) = I_M \cos(\omega t - \theta - 120^\circ)$$

$$i_c(t) = I_M \cos(\omega t - \theta - 240^\circ)$$

PHASE SEQUENCE

$$v_{an}(t) = V_M \cos \omega t$$

$$v_{bn}(t) = V_M \cos(\omega t - 120^\circ)$$

$$v_{cn}(t) = V_M \cos(\omega t + 120^\circ)$$

$$V_{an} = V_M \angle 0^\circ$$

$$V_{bn} = V_M \angle -120^\circ$$

$$V_{cn} = V_M \angle +120^\circ$$

**POSITIVE
SEQUENCE**

$$V_{an} = V_M \angle 0^\circ$$

$$V_{bn} = V_M \angle +120^\circ$$

$$V_{cn} = V_M \angle -120^\circ$$

**NEGATIVE
SEQUENCE**

PHASE SEQUENCE

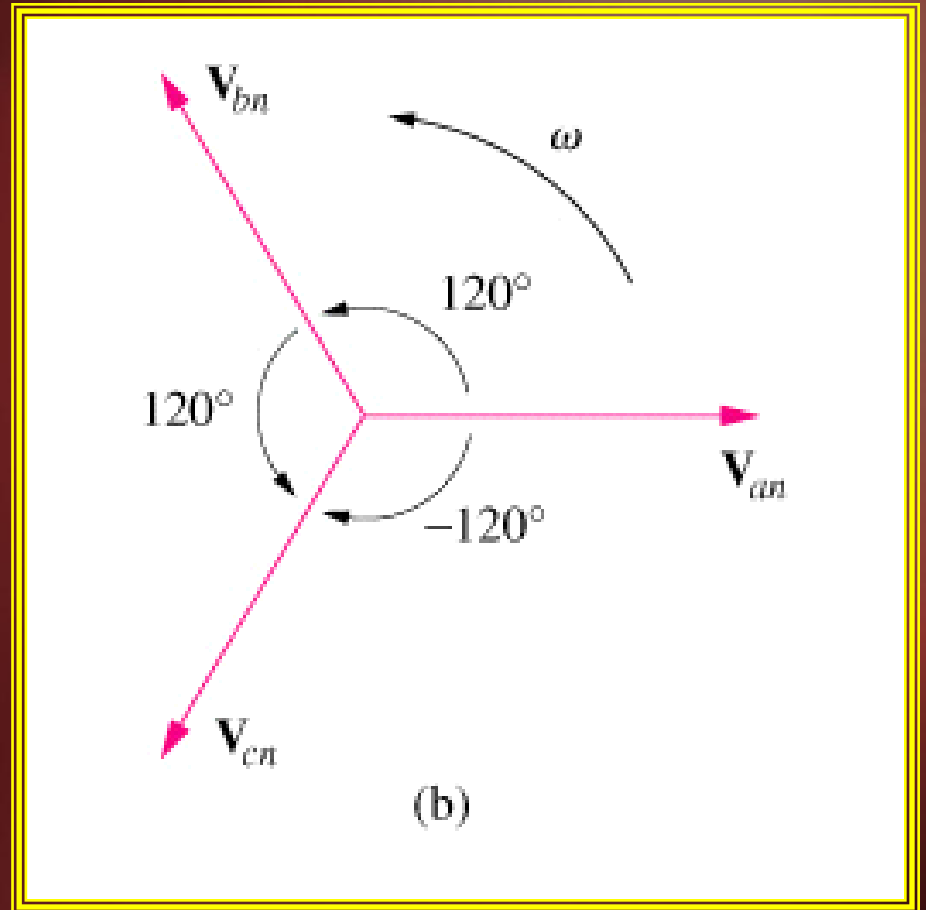
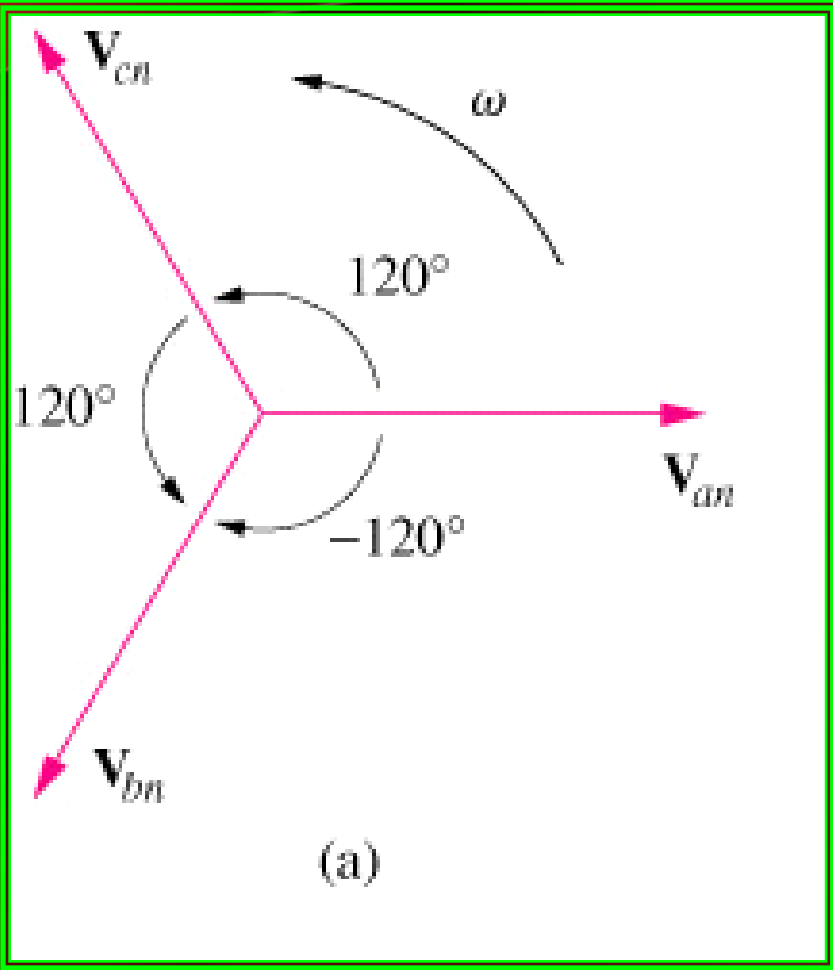

EXAMPLE # 1

- Determine the phase sequence of the set voltages:

$$v_{an} = 200 \cos(\omega t + 10^\circ)$$

$$v_{bn} = 200 \cos(\omega t - 230^\circ)$$

$$v_{cn} = 200 \cos(\omega t - 110^\circ)$$

BALANCED VOLTAGE AND LOAD

- **Balanced Phase Voltage:** all phase voltages are equal in magnitude and are out of phase with each other by 120° .
- **Balanced Load:** the phase impedances are equal in magnitude and in phase.

THREE PHASE CIRCUIT

- POWER
 - The instantaneous power is constant

$$p(t) = p_a(t) + p_b(t) + p_c(t)$$

$$= 3 \frac{V_M I_M}{2} \cos(\theta)$$

$$= 3 V_{rms} I_{rms} \cos(\theta)$$

THREE PHASE CIRCUIT

- Three Phase Power,

$$\mathbf{S}_T = \mathbf{S}_A + \mathbf{S}_B + \mathbf{S}_C = 3 \mathbf{S}_\phi$$

THREE PHASE QUANTITIES

QUANTITY	SYMBOL
Phase current	I_{ϕ}
Line current	I_L
Phase voltage	V_{ϕ}
Line voltage	V_L

PHASE VOLTAGES and LINE VOLTAGES

- **Phase voltage** is measured between the neutral and any line: line to neutral voltage
- **Line voltage** is measured between any two of the three lines: line to line voltage.

PHASE CURRENTS and LINE CURRENTS

- Line current (I_L) is the current in each **line** of the source or load.
- Phase current (I_ϕ) is the current in each **phase** of the source or load.

THREE PHASE CONNECTION

SOURCE-LOAD CONNECTION

SOURCE	LOAD	CONNECTION
Wye	Wye	Y-Y
Wye	Delta	Y- Δ
Delta	Delta	Δ - Δ
Delta	Wye	Δ -Y

SOURCE-LOAD CONNECTION

- Common connection of source: **WYE**
 - Delta connected sources: the circulating current may result in the delta mesh if the three phase voltages are slightly unbalanced.
- Common connection of load: **DELTA**
 - Wye connected load: neutral line may not be accessible, load can not be added or removed easily.

WYE CONNECTION

WYE CONNECTED GENERATOR

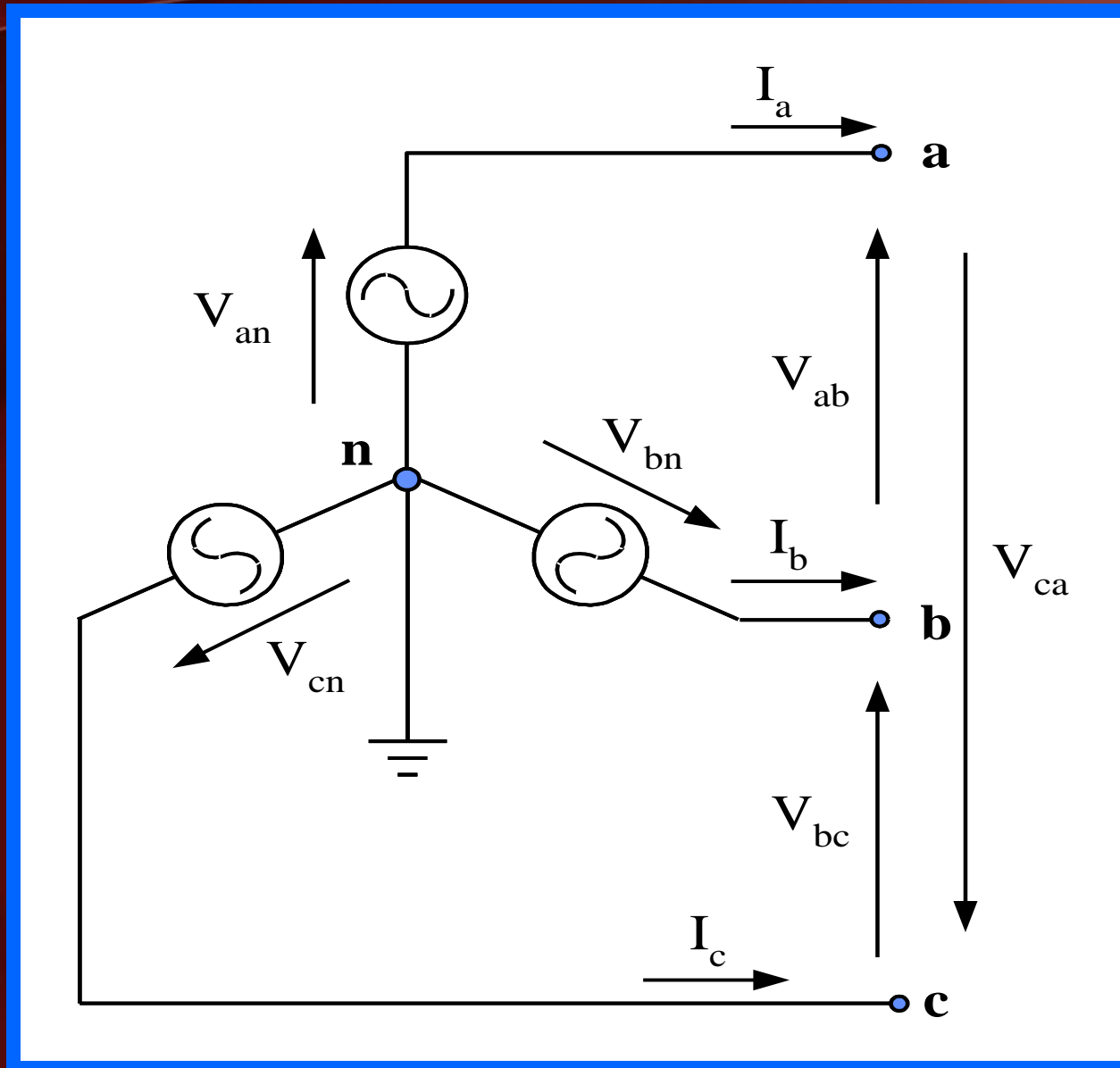

WYE CONNECTED LOAD

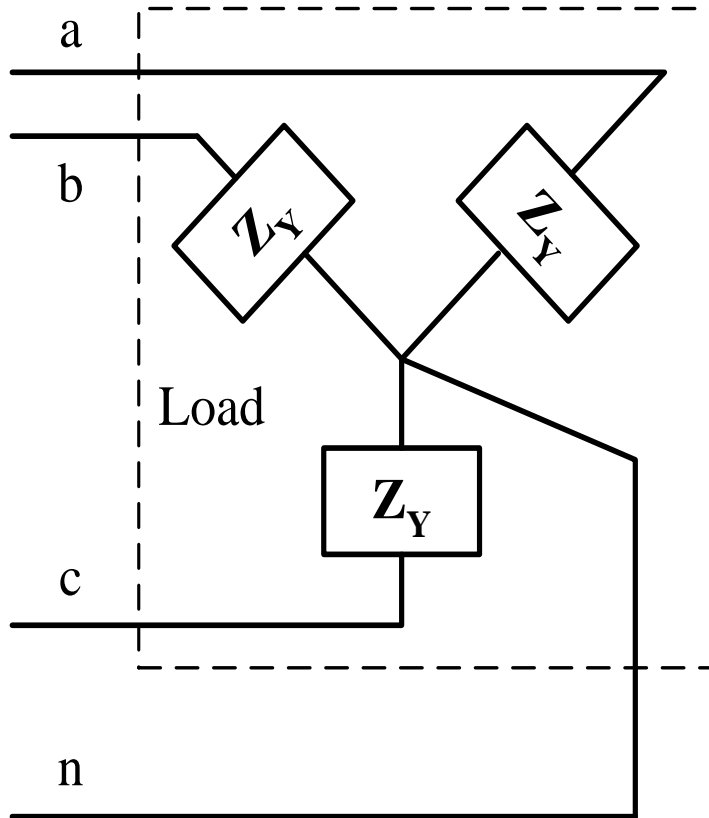

OR

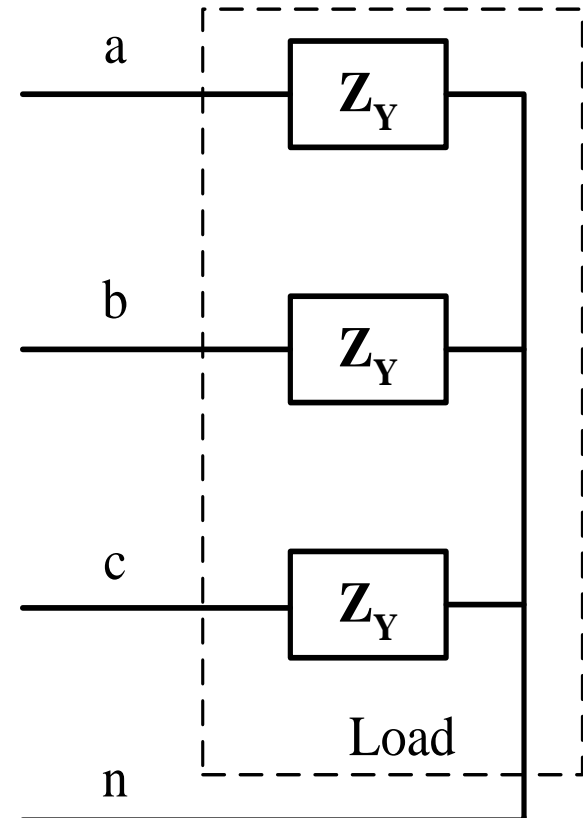

BALANCED Y-Y CONNECTION

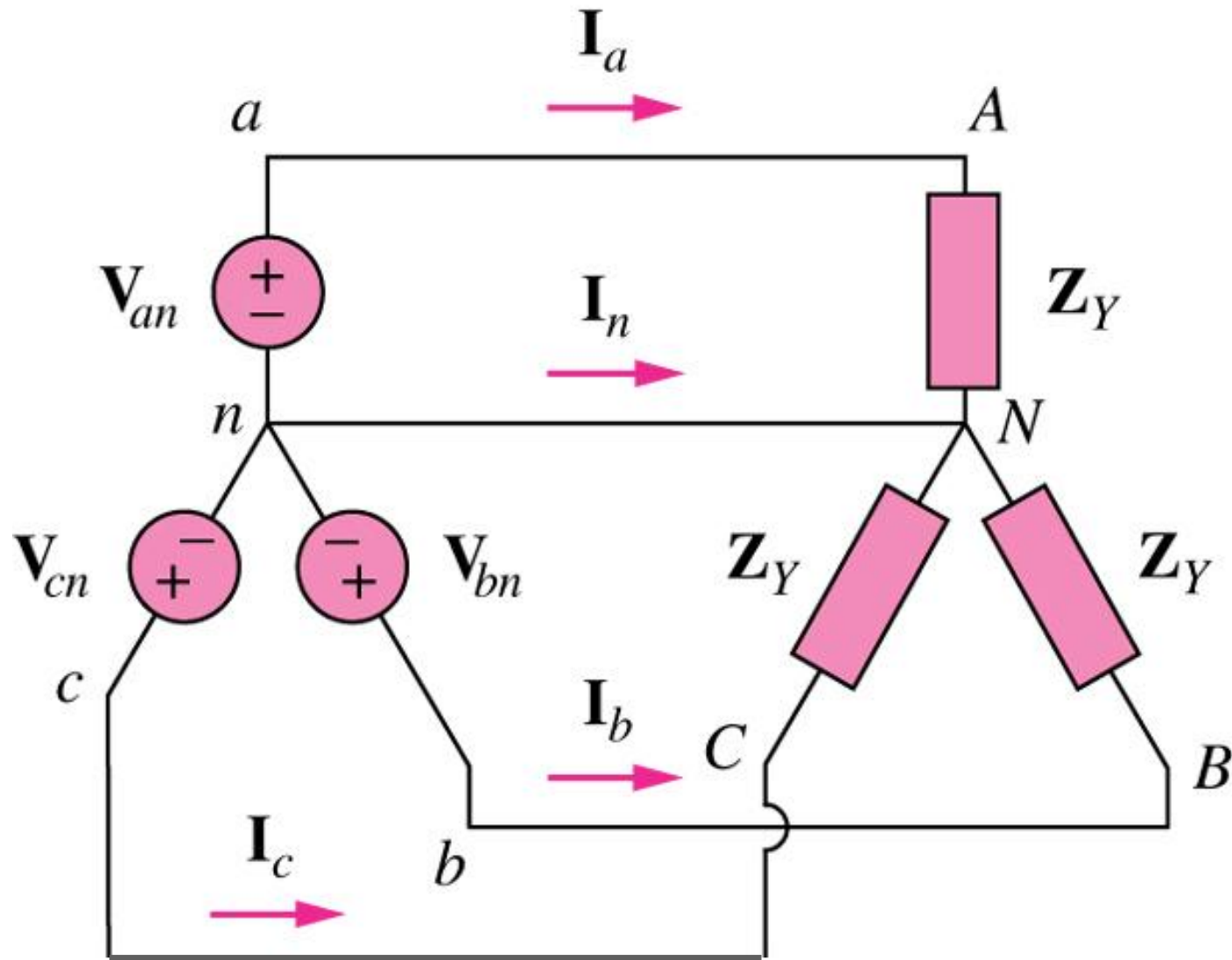

PHASE CURRENTS AND LINE CURRENTS

- In Y-Y system:

$$I_L = I_\phi$$

PHASE VOLTAGES, V_{ϕ}

- Phase voltage is measured between the neutral and any line: line to neutral voltage

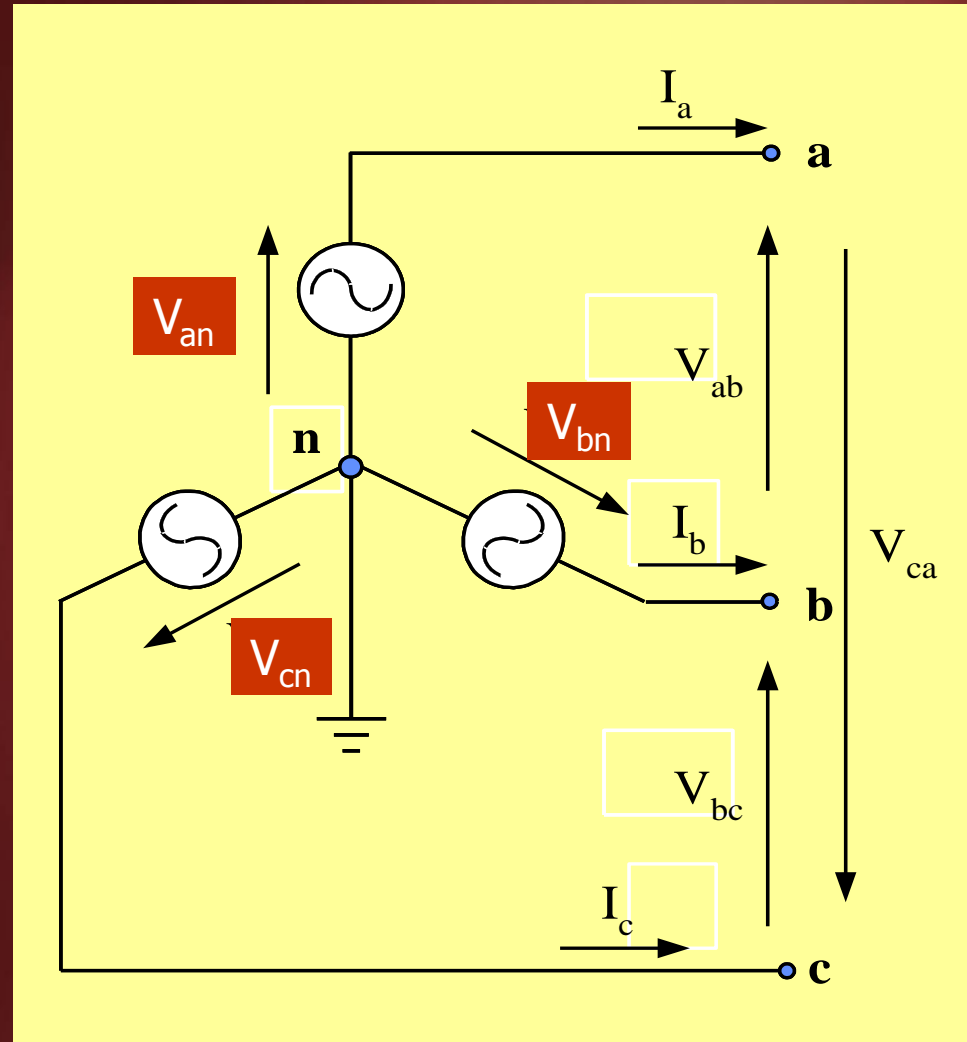

PHASE VOLTAGES, V_{ϕ}

$$V_{an} = V_M \angle 0^{\circ} \quad \text{volt}$$

$$V_{bn} = V_M \angle -120^{\circ} \quad \text{volt}$$

$$V_{cn} = V_M \angle 120^{\circ} \quad \text{volt}$$

LINE VOLTAGES, V_L

- Line voltage is measured between any two of the three lines: line to line voltage.

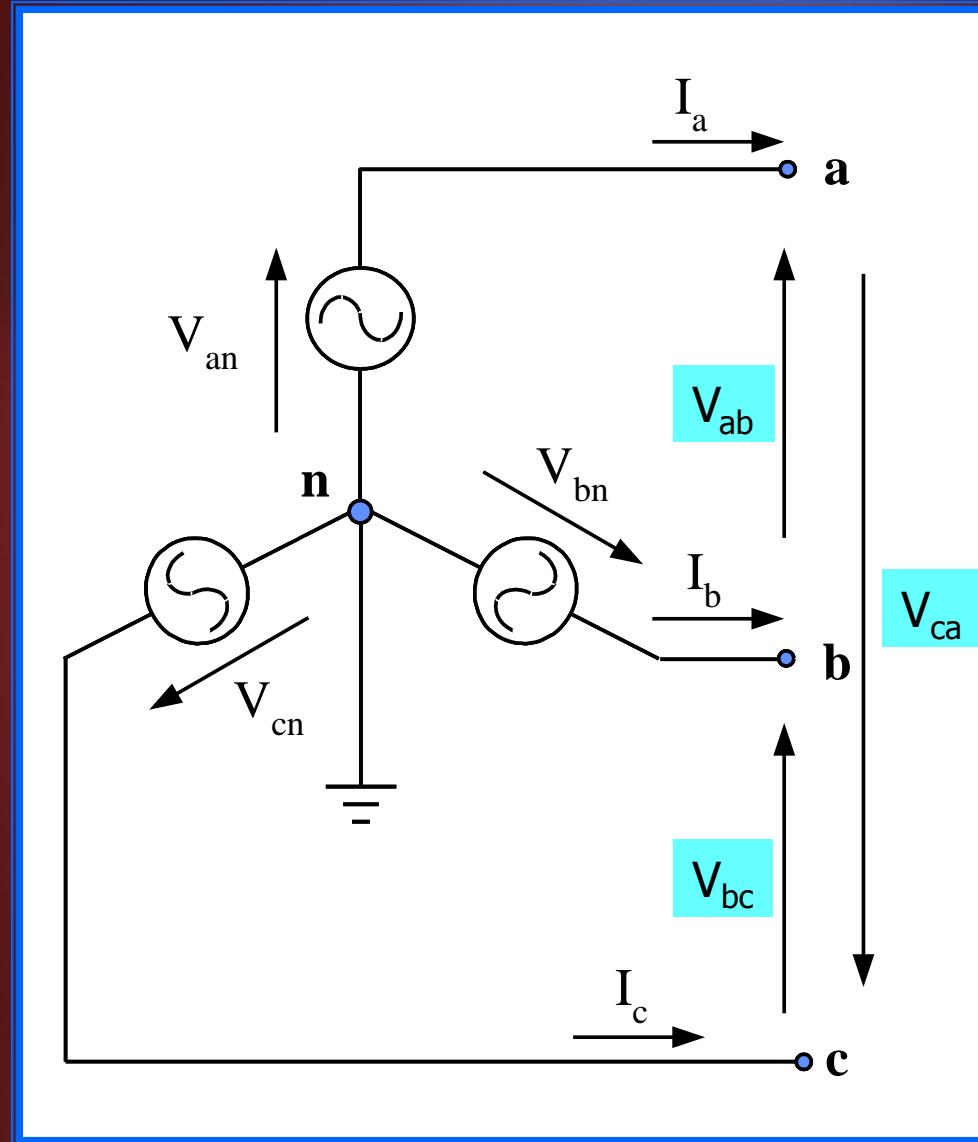

LINE VOLTAGES, V_L

$$V_{ab} = V_{an} - V_{bn}$$

$$V_{bc} = V_{bn} - V_{cn}$$

$$V_{ca} = V_{cn} - V_{an}$$

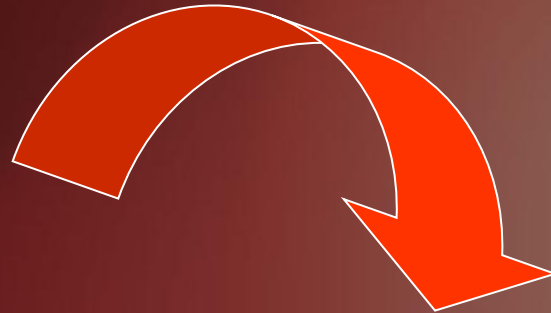

$$V_{ab} = \sqrt{3}V_M \angle 30^\circ$$

$$V_{bc} = \sqrt{3}V_M \angle -90^\circ$$

$$V_{ca} = \sqrt{3}V_M \angle 150^\circ$$

$$V_{an} = V_M \angle 0^\circ \quad \text{volt}$$

$$V_{bn} = V_M \angle -120^\circ \quad \text{volt}$$

$$V_{cn} = V_M \angle 120^\circ \quad \text{volt}$$

**PHASE
VOLTAGE (V_ϕ)**

**LINE
VOLTAGE
(V_L)**

$$V_{ab} = \sqrt{3} V_M \angle 30^\circ \quad \text{volt}$$

$$V_{bc} = \sqrt{3} V_M \angle -90^\circ \quad \text{volt}$$

$$V_{ca} = \sqrt{3} V_M \angle 150^\circ \quad \text{volt}$$

PHASE DIAGRAM OF V_L AND V_ϕ

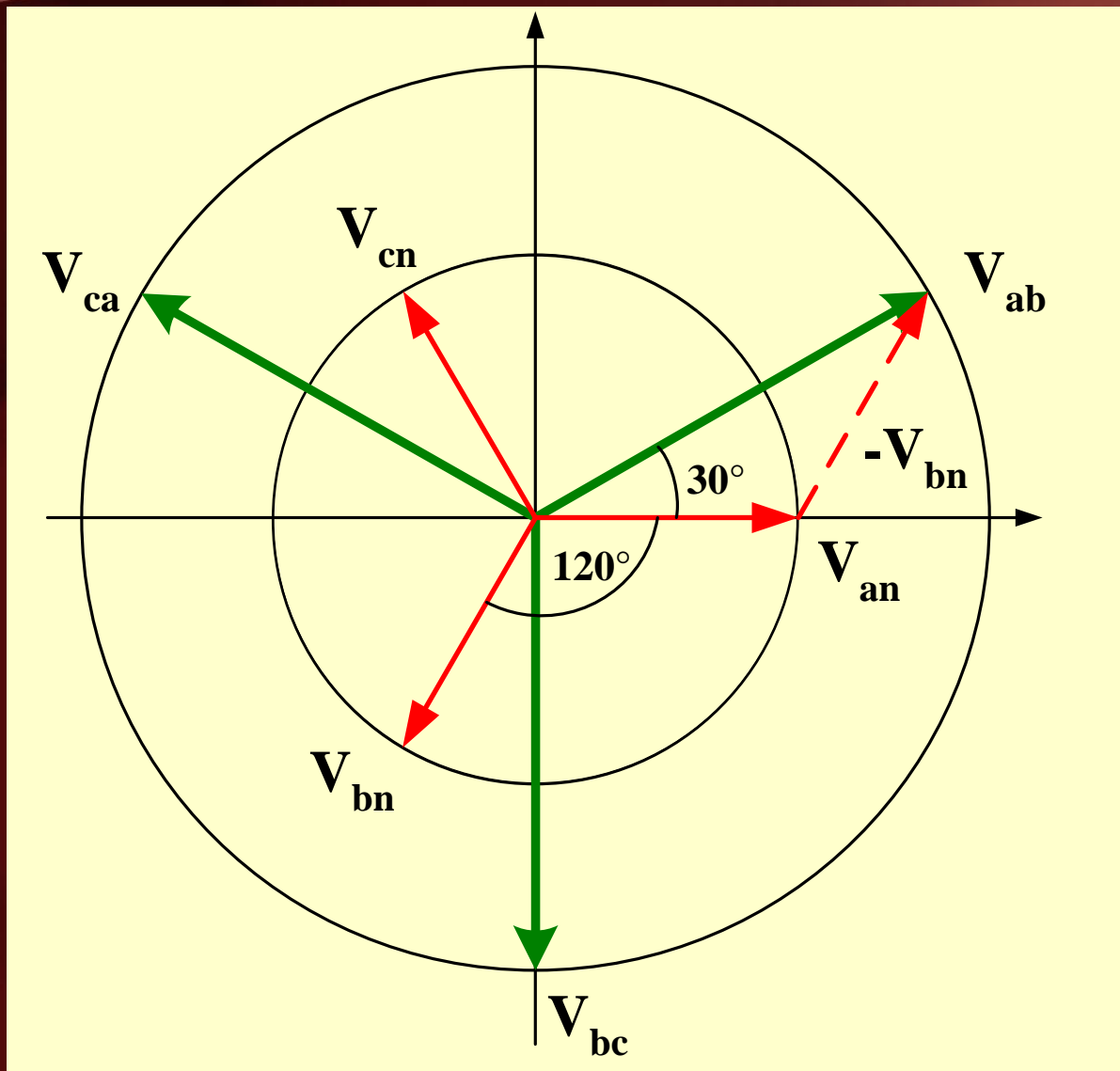

PROPERTIES OF PHASE VOLTAGE

- All phase voltages have the same magnitude,

$$V_{\phi} = |V_{an}| = |V_{bn}| = |V_{cn}|$$

- Out of phase with each other by 120°

PROPERTIES OF LINE VOLTAGE

- All line voltages have the same magnitude,

$$V_L = |V_{ab}| = |V_{bc}| = |V_{ca}|$$

- Out of phase with each other by 120°

RELATIONSHIP BETWEEN V_ϕ and V_L

1. Magnitude

$$|V_L| = \sqrt{3} |V_\phi|$$

2. Phase

- V_L **LEAD** their corresponding V_ϕ by **30°**

$$\angle V_L = \angle V_\phi + 30^\circ$$

EXAMPLE 1

- Calculate the line currents

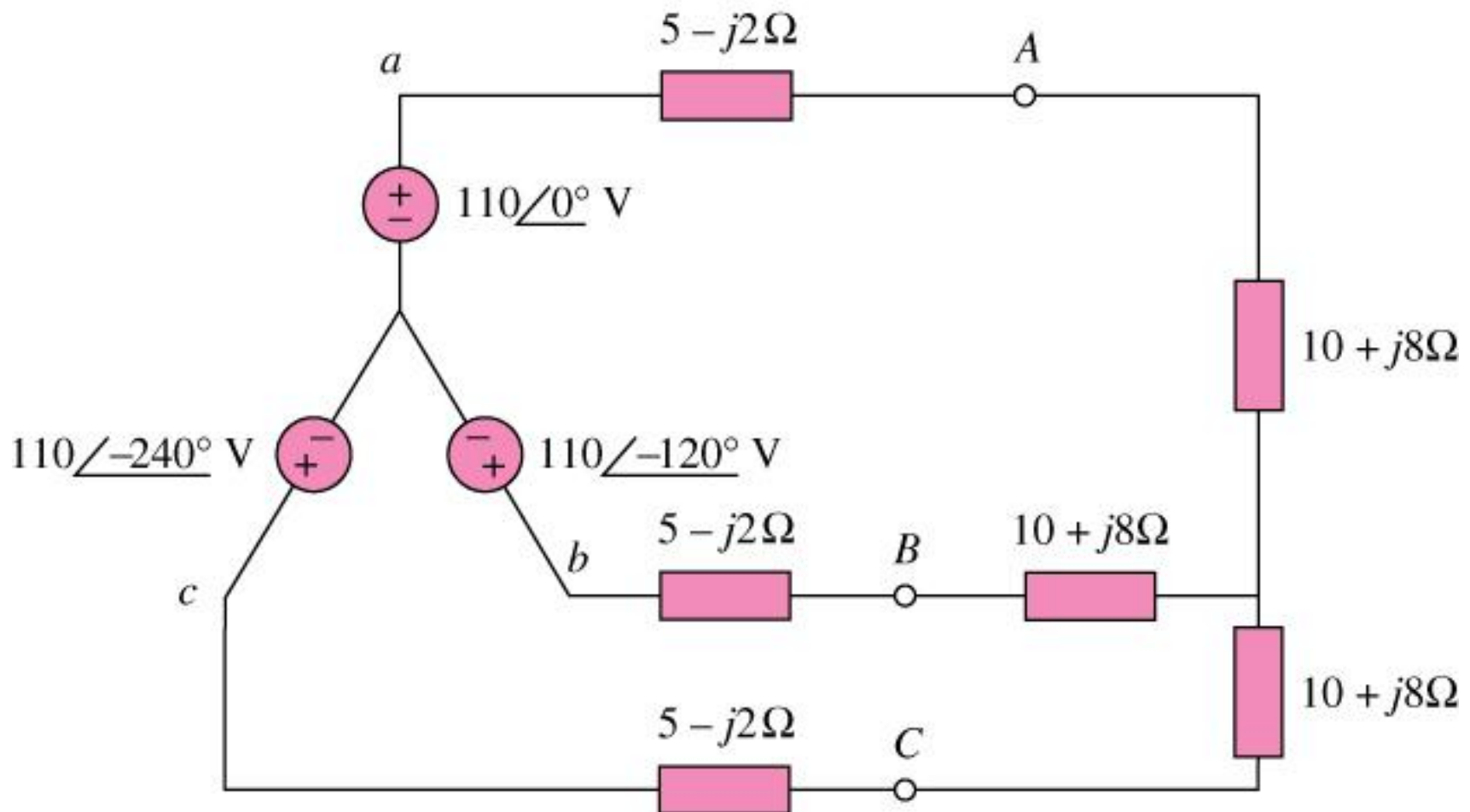

DELTA CONNECTION

DELTA CONNECTED SOURCES

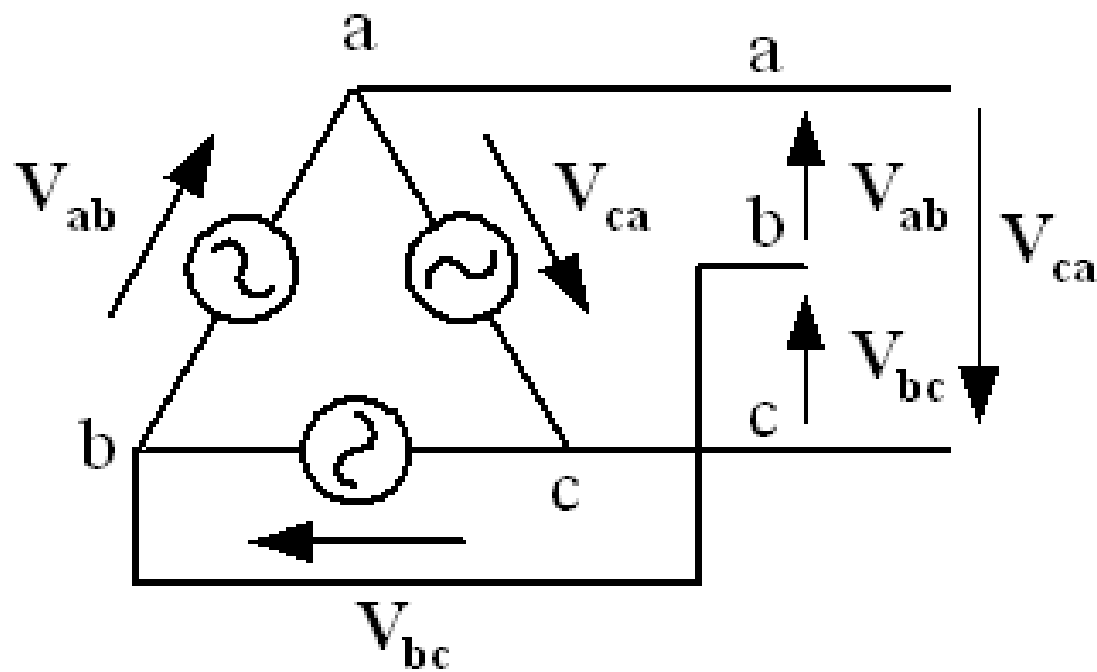

DELTA CONNECTED LOAD

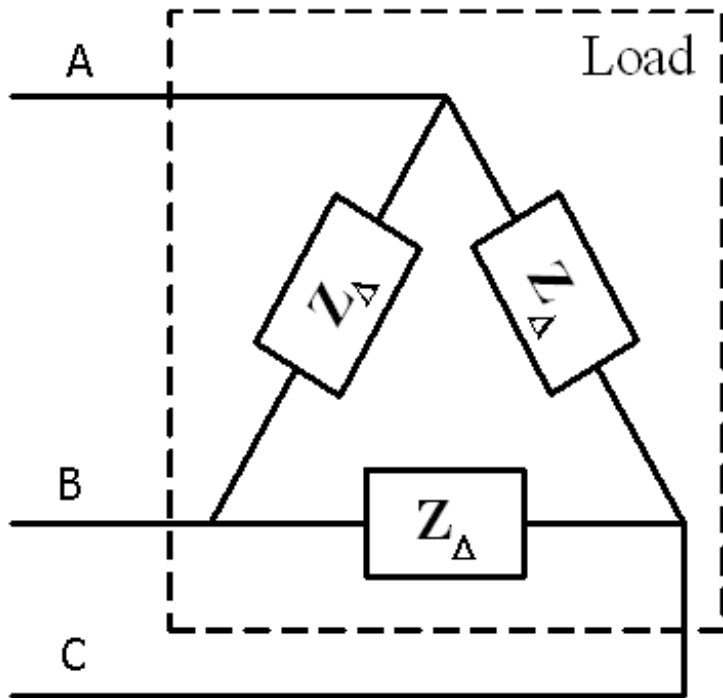

OR

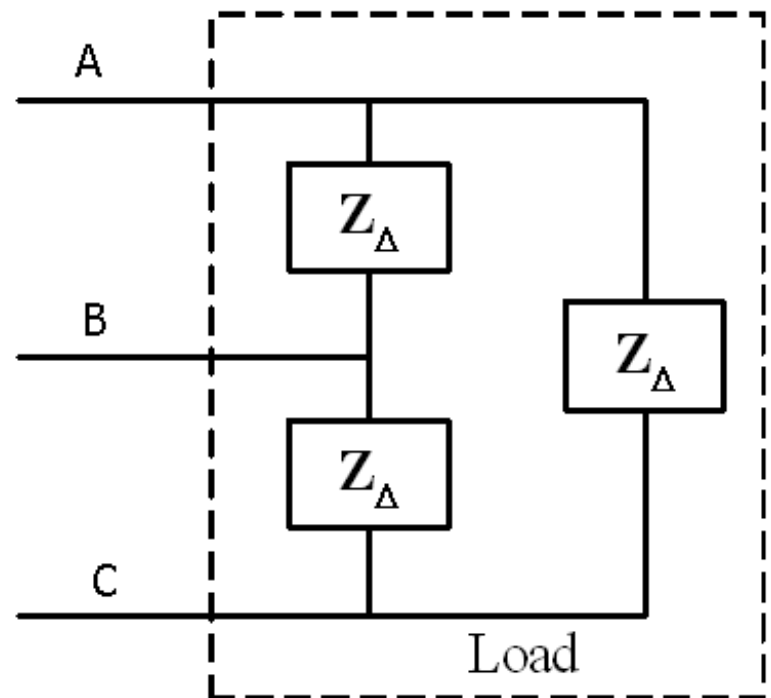

BALANCED Δ - Δ CONNECTION

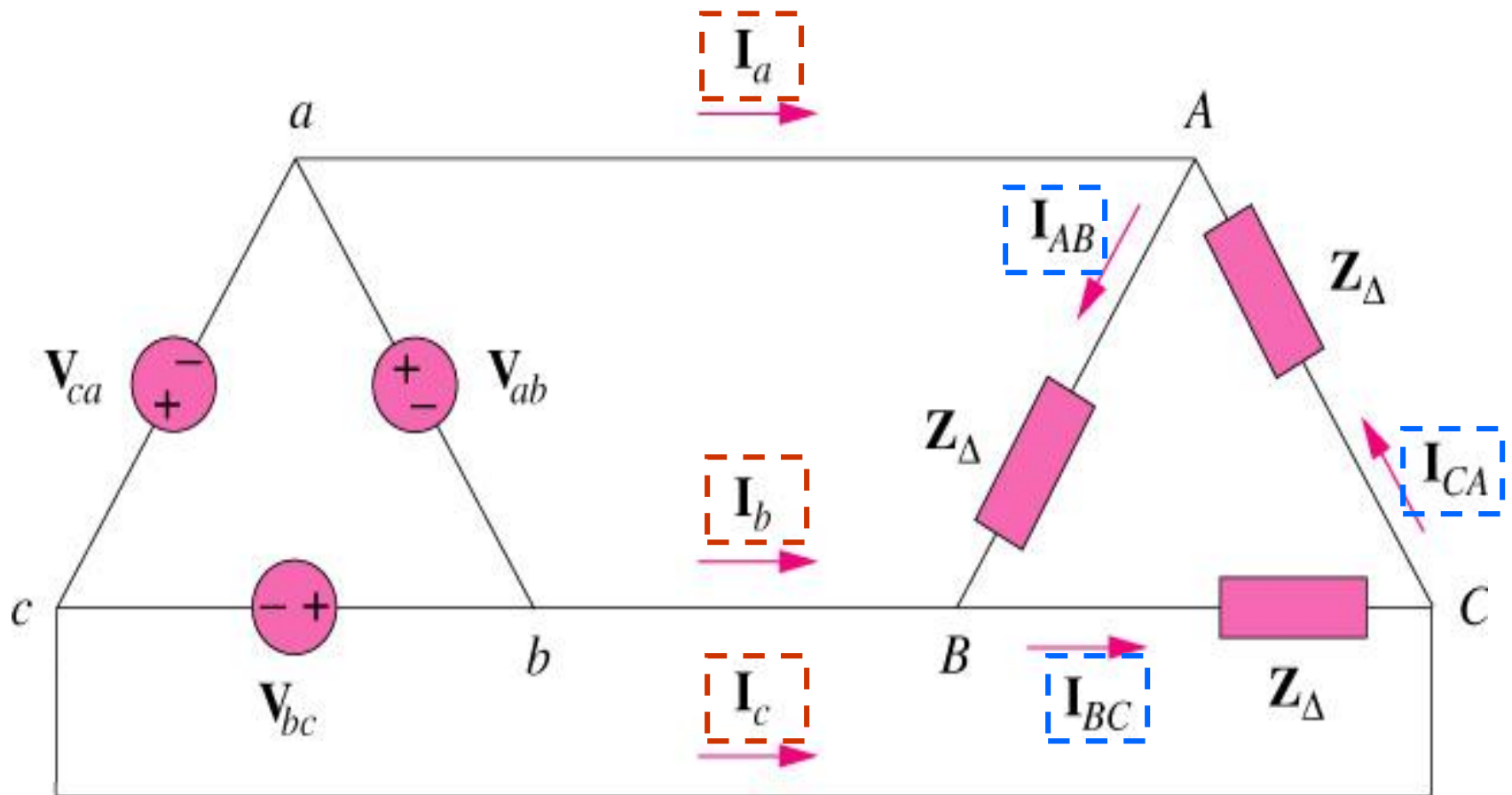

PHASE VOLTAGE AND LINE VOLTAGE

- In Δ - Δ system, line voltages equal to phase voltages:

$$V_L = V_\phi$$

PHASE VOLTAGE, V_ϕ

- Phase voltages are equal to the voltages across the load impedances.

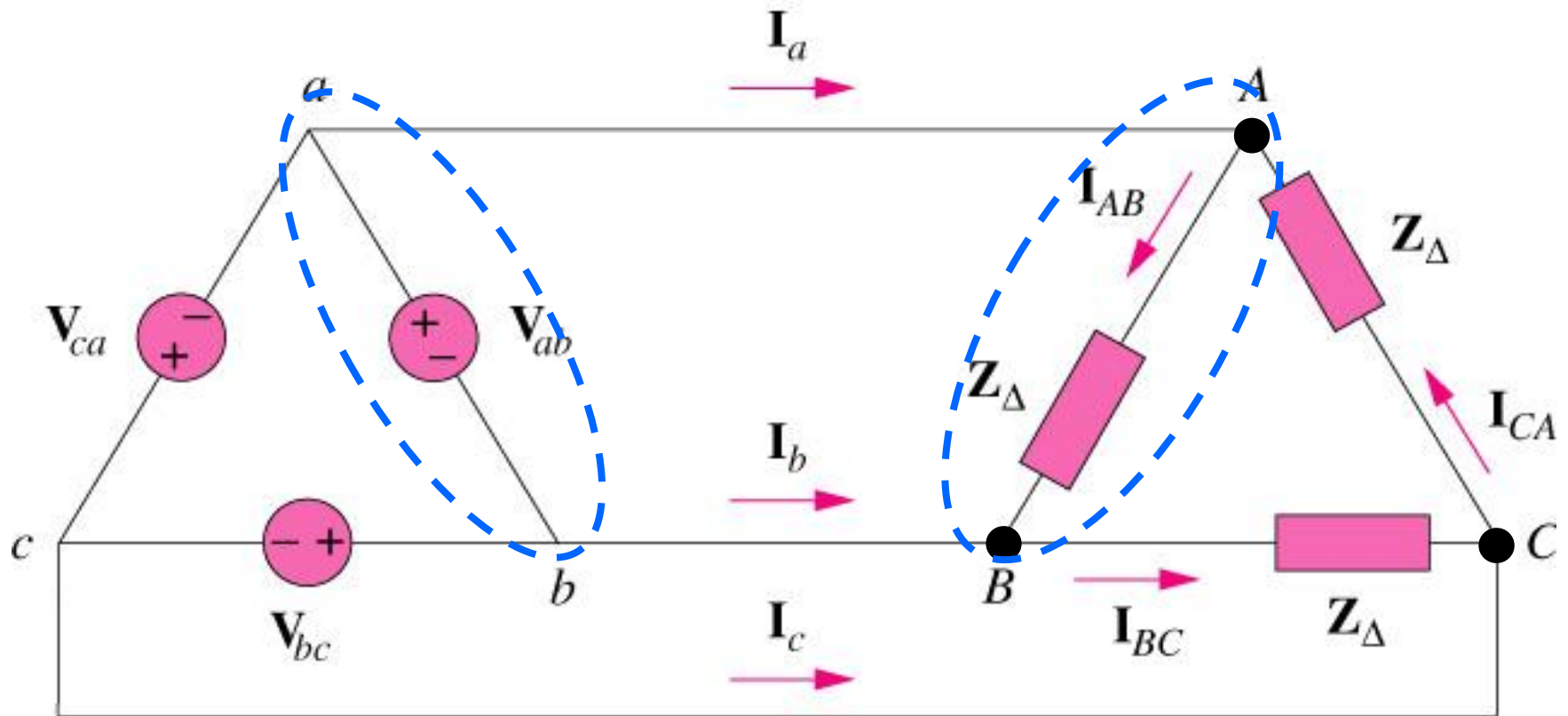

PHASE CURRENTS, I_{ϕ}

- The phase currents are obtained:

$$I_{AB} = \frac{V_{AB}}{Z_{\Delta}}, \quad I_{BC} = \frac{V_{BC}}{Z_{\Delta}}, \quad I_{CA} = \frac{V_{CA}}{Z_{\Delta}}$$

LINE CURRENTS, I_L

- The line currents are obtained from the phase currents by applying KCL at nodes A, B, and C.

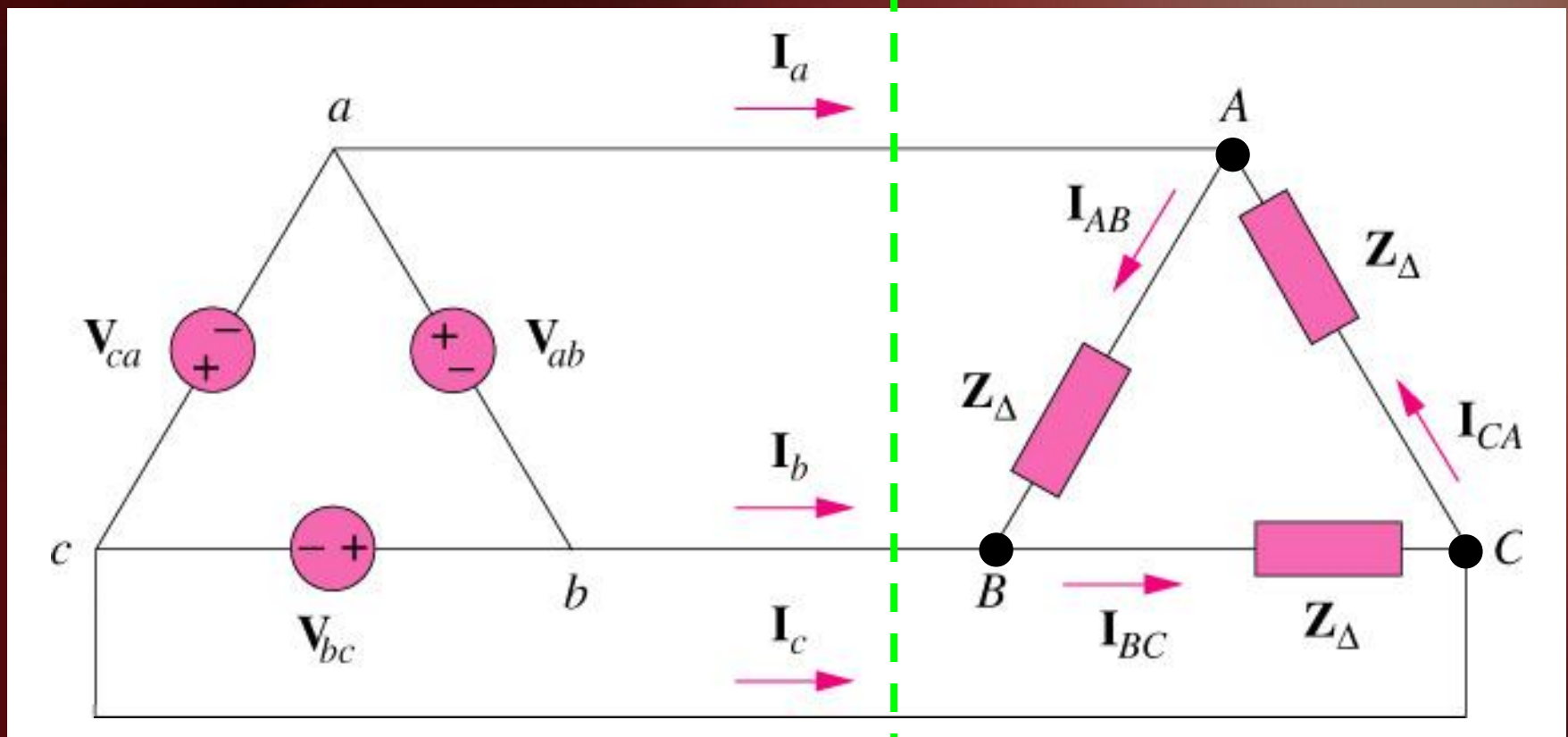

LINE CURRENTS, I_L

$$I_a = I_{AB} - I_{CA}$$

$$I_b = I_{BC} - I_{AB}$$

$$I_c = I_{CA} - I_{BC}$$



$$I_a = \sqrt{3} I_{AB} \angle -30^\circ$$

$$I_b = I_a \angle -120^\circ$$

$$I_c = I_a \angle +120^\circ$$

PHASE CURRENTS (I_ϕ)

$$I_{AB} = \frac{V_{AB}}{Z_\Delta}$$

$$I_{BC} = \frac{V_{BC}}{Z_\Delta}$$

$$I_{CA} = \frac{V_{CA}}{Z_\Delta}$$

LINE CURRENTS (I_L)

$$I_a = \sqrt{3} I_{AB} \angle -30^\circ$$

$$I_b = I_a \angle -120^\circ$$

$$I_c = I_a \angle +120^\circ$$

PHASE DIAGRAM OF I_L AND I_{ϕ}

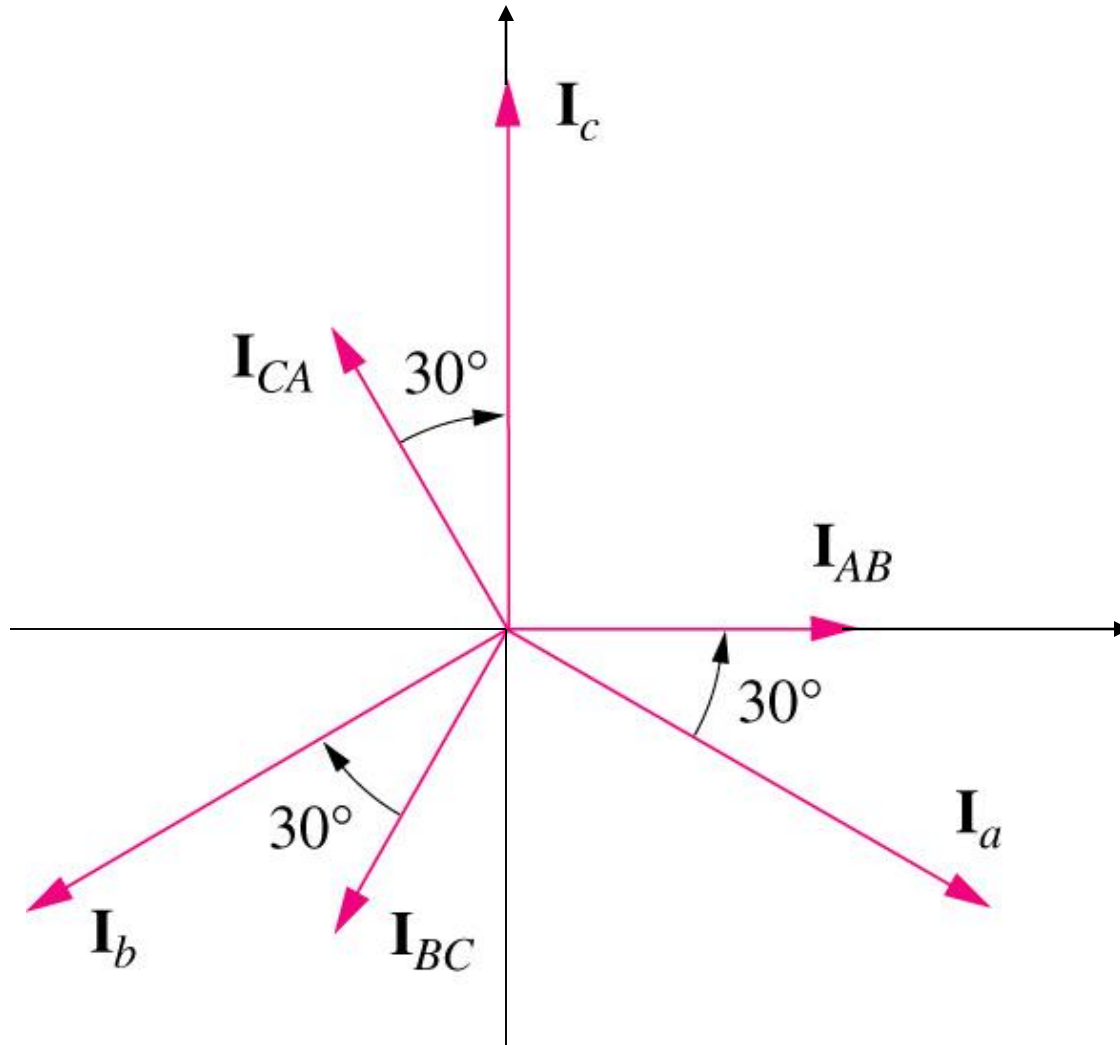

PROPERTIES OF PHASE CURRENT

- All phase currents have the same magnitude,

$$I_{\phi} = |I_{AB}| = |I_{BC}| = |I_{CA}| = \left| \frac{V_{\phi}}{Z_{\Delta}} \right|$$

- Out of phase with each other by 120°

PROPERTIES OF LINE CURRENT

- All line currents have the same magnitude,

$$I_L = |I_a| = |I_b| = |I_c|$$

- Out of phase with each other by 120°

RELATIONSHIP BETWEEN I_ϕ and I_L

1. Magnitude

$$|I_L| = \sqrt{3}|I_\phi|$$

2. Phase

- I_L **LAG** their corresponding I_ϕ by **30°**

$$\angle I_L = \angle I_\phi - 30^\circ$$

EXAMPLE

A balanced delta connected load having an impedance $20-j15 \Omega$ is connected to a delta connected, positive sequence generator having $V_{ab} = 330 \angle 0^\circ \text{ V}$. Calculate the phase currents of the load and the line currents.

Given Quantities

$$\Rightarrow Z_{\Delta} = 20 - j15 \Omega = 25 \angle -36.87^{\circ}$$

$$\Rightarrow V_{ab} = 330 \angle 0^{\circ}$$

Phase Currents

$$I_{AB} = \frac{V_{AB}}{Z_{\Delta}} = \frac{330 \angle 0^{\circ}}{25 \angle -36.87^{\circ}} = 13.2 \angle 36.87^{\circ} \text{ A}$$

$$I_{BC} = I_{AB} \angle -120^{\circ} = 13.2 \angle -83.13^{\circ} \text{ A}$$

$$I_{CA} = I_{AB} \angle +120^{\circ} = 13.2 \angle 156.87^{\circ} \text{ A}$$

Line Currents

$$\begin{aligned} I_a &= I_{AB} \sqrt{3} \angle -30^\circ \\ &= (13.2 \angle 36.87^\circ) (\sqrt{3} \angle -30^\circ) \text{ A} \\ &= 22.86 \angle 6.87^\circ \end{aligned}$$

$$I_b = I_a \angle -120^\circ = 22.86 \angle -113.13^\circ \text{ A}$$

$$I_c = I_a \angle +120^\circ = 22.86 \angle 126.87^\circ \text{ A}$$

BALANCED WYE-DELTA SYSTEM

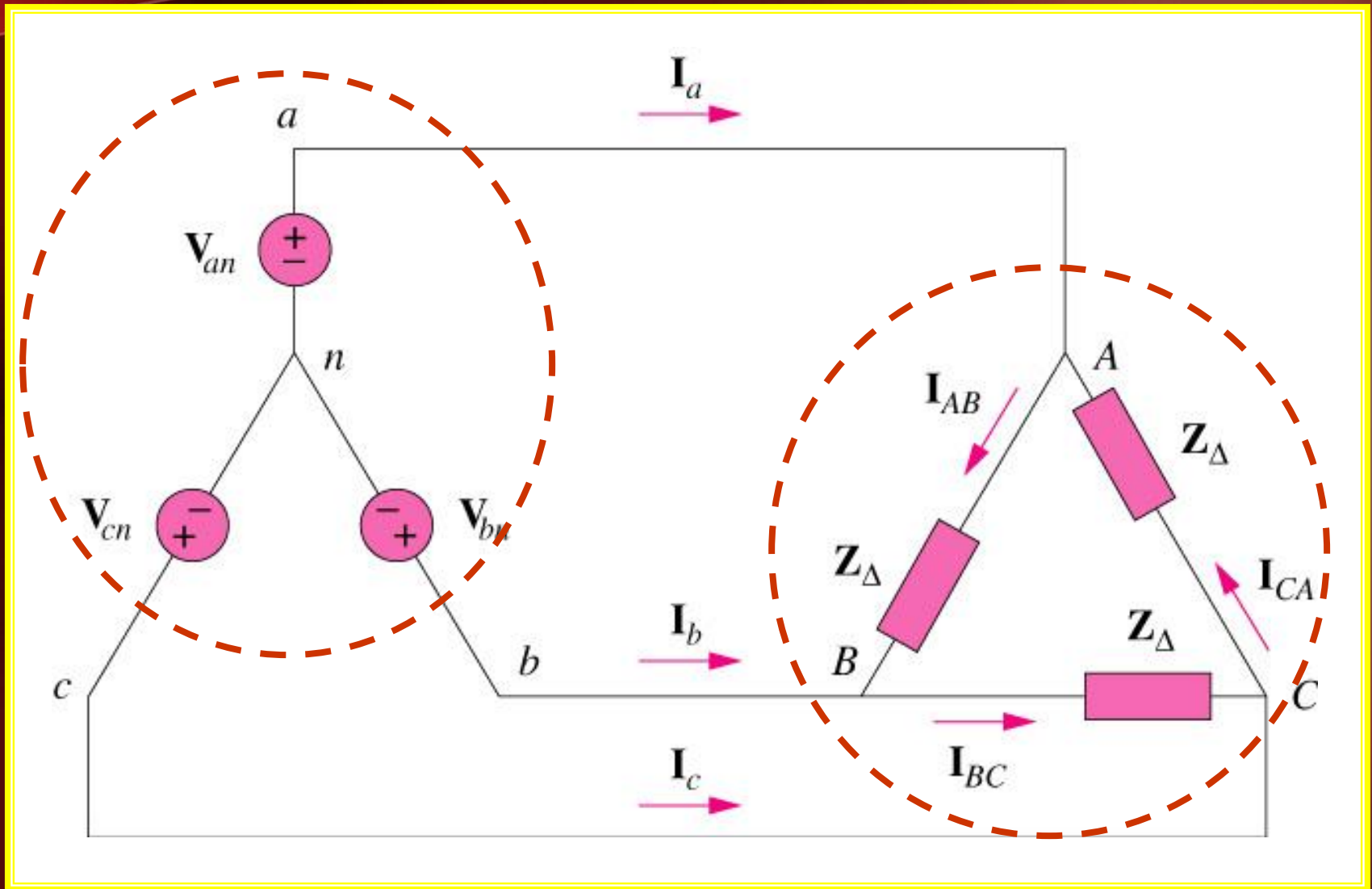

EXAMPLE 2

A balanced positive sequence Y-
connected source with $V_{an} = 100 \angle 10^\circ \text{ V}$
is connected to a Δ -connected
balanced load $(8 + j4) \Omega$ per phase.
Calculate the phase and line currents.

THREE PHASE POWER MEASUREMENT

EXAMPLE 3

Determine the total power (P), reactive power (Q), and complex power (S) at the source and at the load

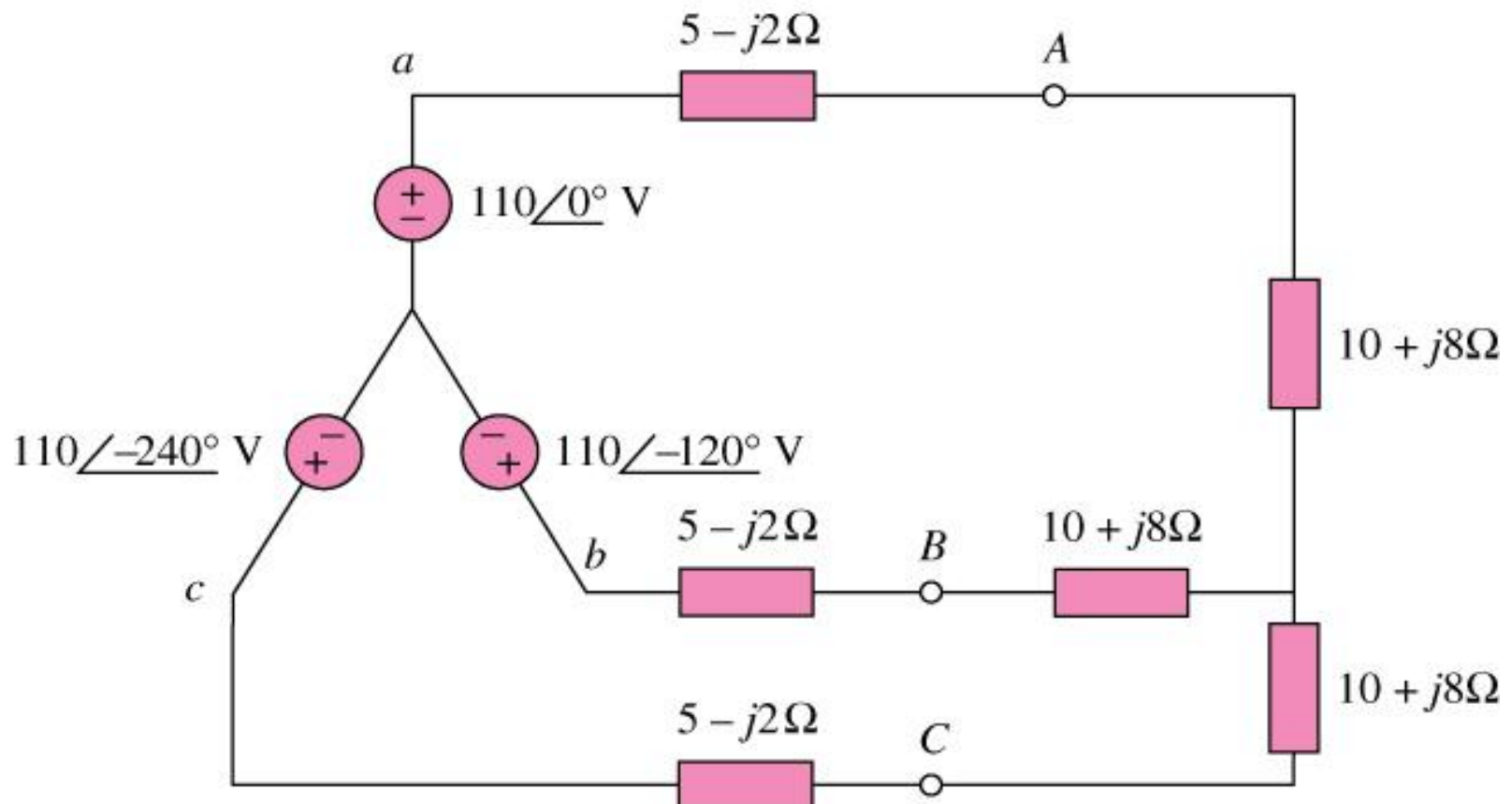

EXAMPLE #4

A three phase motor can be regarded as a **balanced Y-load**. A three phase motor draws **5.6 kW** when the line voltage is **220 V** and the line current is **18.2 A**. Determine the power factor of the motor

THANK YOU