

DEPARTMENT OF ELECTRICAL ENGINEERING

FIRST YEAR E.T. LAB – EXP.NO. – 1

I. CHARACTERISTICS OF LAMPS

OBJECTIVE:

- i) To obtain the non-linear Volt – Amp (V–I) characteristics of Incandescent (Tungsten & Carbon filament) lamps and the steady state operation of a typical circuit containing both linear & resistive elements
- ii) To study different types of lamps and compare their efficacies.

1. INCANDESCENT LAMPS

CIRCUIT DIAGRAM:

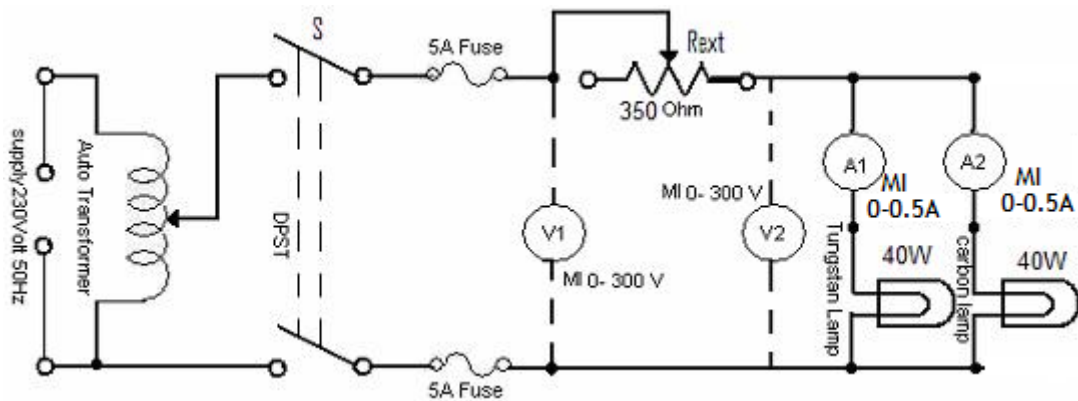

Fig 1: Circuit diagram for testing of Tungsten and Carbon filament Lamps

PROCEDURE:

1. Choose the appropriate ratings of the Ammeters, Voltmeters and Fuse wire. Available ranges are: Fuse: 3A; 5A; 10A; Ammeter: 0 – 1A, 0 – 0.5 – 1A; Voltmeter: 0 – 150V; 0 – 300V.
2. Set up the circuit as shown in Fig.1 with the lamps and instruments as indicated. Keep the switch S open.
3. Set external resistance $R_{ext} \simeq 0$ and the autotransformer for zero output voltage. Close the switch S.
4. Increase the autotransformer output voltage in steps of 20/30 V, until the full voltage is obtained. At each step, note the readings of V_1 , V_2 , A1 and A2 and record them in Table 1.
5. Repeat step 4 decreasing output voltage from full to zero volts.
6. Increase the resistance R_{ext} to maximum value and note all the meter readings for maximum autotransformer output voltage. Enter the readings in the appropriate columns of Table 2. Set R_{ext} at another value (mid range) and repeat the above steps for this value of R_{ext} .

RESULT:

Table 1: Observation for $v-i$ characteristics of the lamps.

SL. No.	V_1 (V)	V_2 (V)	I_1 (Tungsten Lamp) (A)			I_2 (Carbon Lamp) (A)		
			Increase	Decrease	Mean	Increase	Decrease	Mean

Table 2: Observation/Estimation of Steady state operation

$R_{ext} = 170$ ohms (max.), $V_0 =$ Input Voltage (Reading of Voltmeter V_1)

V_{10} (V) = Voltage across the lamps (Reading of voltmeter V_2)

Input	Observed Values			Estimated Values		
Voltage V_0 (V)	I_{10} (A)	I_{20} (A)	V_{10} (V)	I_{10} (A)	I_{20} (A)	V_{10} (V)

Subscript '0' is used to indicate steady - state operation.

Graph (Refer to Fig. 2)

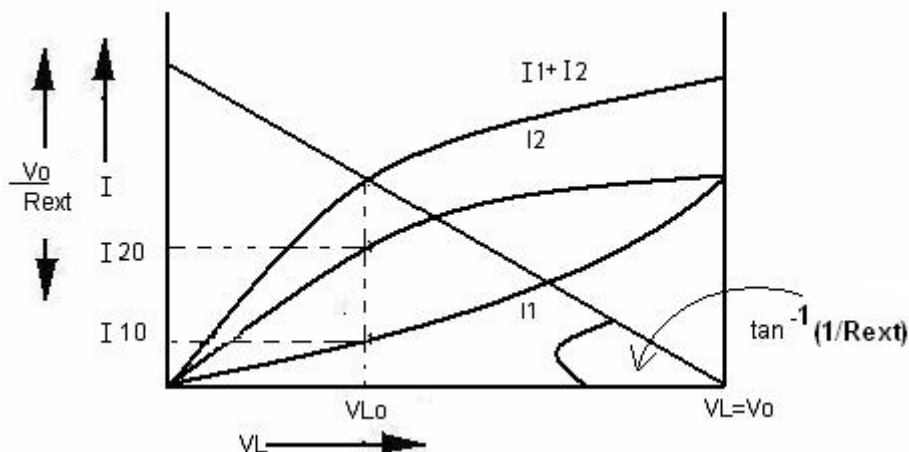

Fig 2: $V-I$ Characteristics and Load Lines for the circuit of Fig 1

1. Plot I_1 , I_2 and $I_1 + I_2$ as a function of voltage, V_1 .
2. Draw the load line representing the characteristics of linear resistive element R_{ext} of the circuit.
3. The point of intersection of this load line with the resultant nonlinear characteristics determines the steady state condition of the circuit. Estimated values of I_1 , I_2 and V_1 are indicated in Fig. 2. Enter them in Table 2.

DISCUSSION:

1. How will you interpret the $v-i$ characteristics of two different incandescent lamps?
2. Why do the readings differ for increasing and decreasing values of the lamp voltages?
3. Account for the differences, if any, between the predicted and the observed steady state operating points of the circuit.

II. LAMP EFFICACIES

OBJECTIVE: To study different types of lamps and compare their efficacies.

CIRCUIT DIAGRAM:

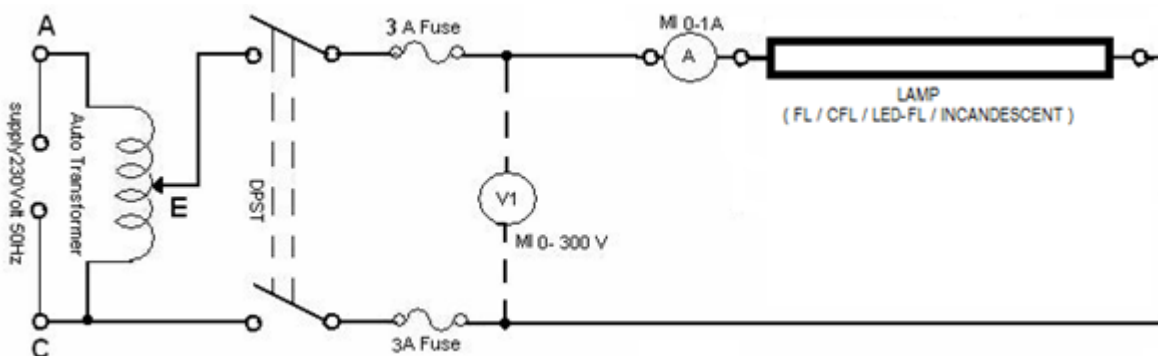

Fig 3: Circuit diagram for study of Lamp efficacies

PROCEDURE:

1. Set up the circuit as shown in Fig.3 with (a) conventional FL using electronic ballast. Keep the DPST switch open.
2. With the autotransformer at zero output position, close the switch.
3. Increase the autotransformer output gradually until the lamp starts to glow in a stable manner. Note the voltage in Table 3. Set the voltage, V_1 to 110V. Note the illumination at distances of 1 foot and 2 feet from the surface of the lamp. Repeat above for 220 V AC, 110 V DC and 220 V DC at V_1 . **Remove the autotransformer when using DC supply.** Tilt/suitably locate the lux-meter such that it reads the maximum at the distance selected. For all FL lamps try to take the reading towards the middle of the lamp
4. Repeat steps 1, 2 and 3 with (b) a CFL, (c) LED tubular lamp and (d) a tungsten-filament incandescent lamp for all the four voltages. Note your readings in Tables 3 (b), (c) and (d), all similar to table 3 (a).
5. In each case, measure the ambient illumination (Lux) with the lamp switched OFF and the Lux-meter oriented in the direction of the lamp. Subtract this value from all the illumination values that you measure for the each of the lamps. This will give the actual illumination for only that lamp.

RESULT:

Table 3(a): Lamp efficacy test.

Lamp Type: FL electronic ballast, Make, _____ W, _____ V, _____, Lumens _____						
Sl No	Voltage (V)	Current (Amps)	Voltage x Current (VA)	Lux @ 1'	Lux @ 2'	Striking voltage (v)
1	110 V AC					
2	220 V AC					
3	110 V DC					
4	220 V DC					

Identical tables 3(b), 3 (c) and 3 (d) for the other lamps

DISCUSSION:

1. Voltage x Current do not equal rated power. Why?
2. Which house-hold lamps work with both AC and DC?
3. Comment on the efficacy (Lumens/watt) of different types of lamps.
4. Comment on the efficacy of the lamps at different input voltages and for AC and DC supplies.
5. Discuss the function(s) of the choke in the conventional (not electronic) FL lamp circuit. Can it be replaced by a resistor? How can you know if a FL uses a conventional or an electronic ballast?