



❖ ***INTERRUPTION OF
CAPACITIVE CURRENT***

❖ ***Dc circuit
breaking***

INTERRUPTION OF CAPACITIVE CURRENT

Effect:

- The interruption of capacitive current produces high voltage transients across the gap of the circuit breaker.

When?

- This occurs when an unloaded long transmission line or a capacitor bank is switched off.



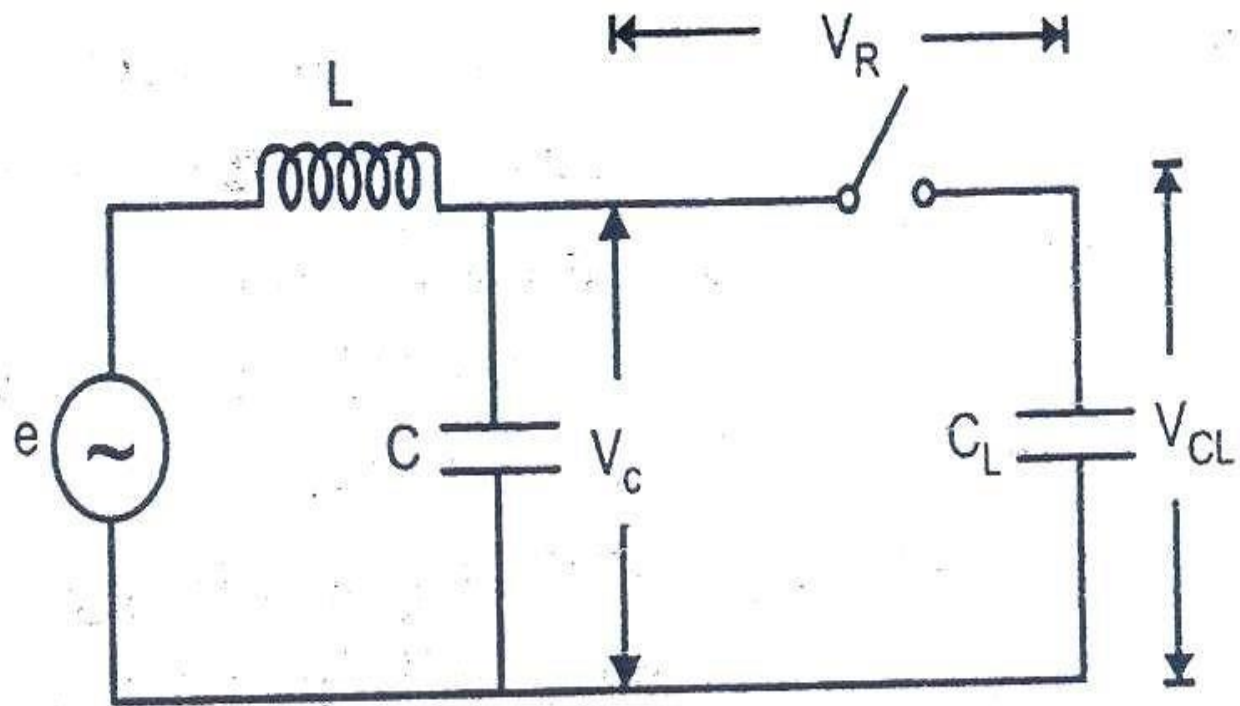

(a) Electrical circuit of a simple power system



- Considering an electrical circuit of a simple power system

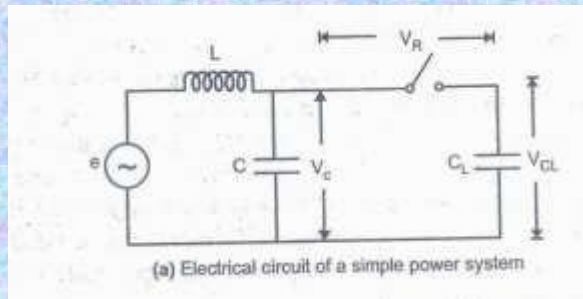

• C → stray capacitance of the circuit breaker

• C_L → line capacitance



TRANSIENT VOLTAGE ACROSS THE GAP OF THE CIRCUIT BREAKER WHEN THE CAPACITIVE CURRENT IS INTERRUPTED

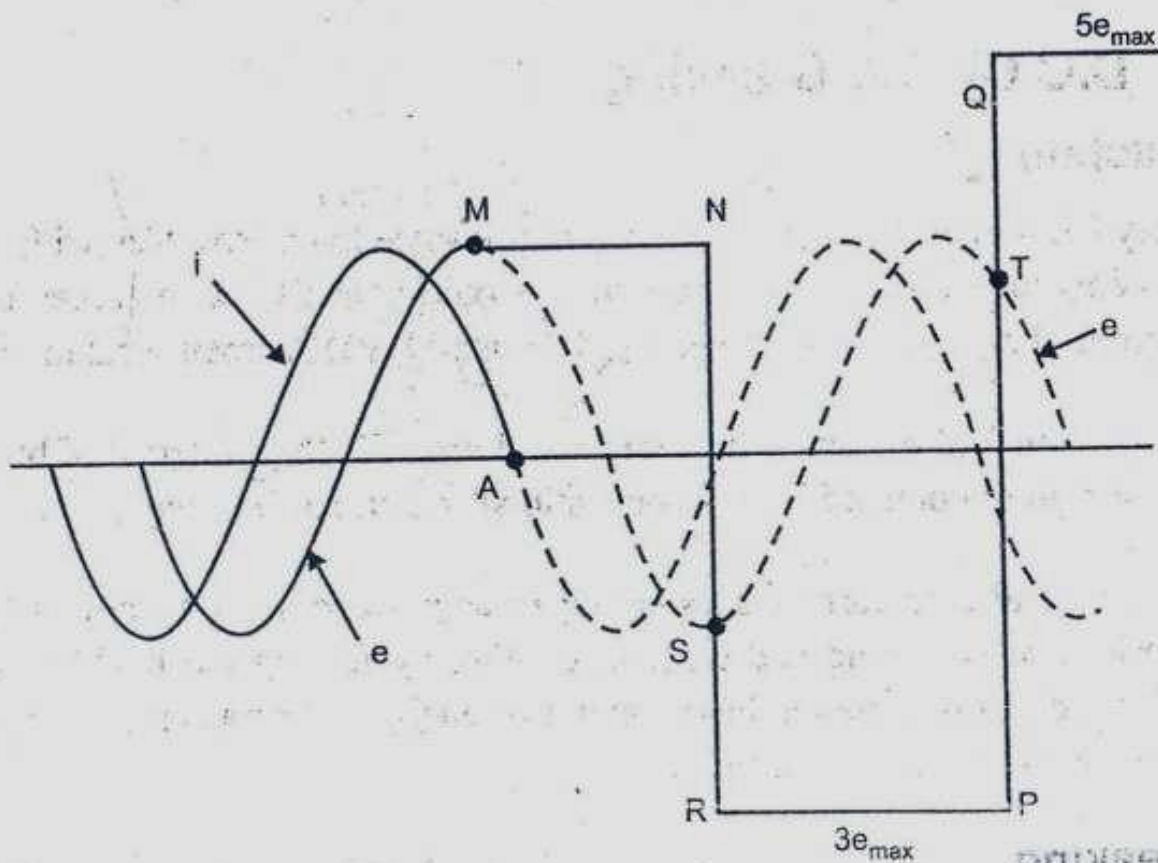

(b) Transient voltage across the gap of the circuit breaker

At the instant M

- ❑ The capacitive current is 0.
- ❑ System voltage is maximum

➤ **If interruption occurs**

- ❑ Capacitor C_L remains charged at the maximum value of system voltage.

After the instant M

- ❑ Voltage across the breaker gap is the difference of V_c and V_{cL} .



At the instant N

- The voltage across the gap is twice the maximum
- Value of V_c .

If the breaker restrikes

- The voltage across the gap become partially zero.
- Voltage falls from $2V_{c_{max}}$ to zero.
- A severe high frequency oscillation occurs (about the point S)
- Interrupted again.(if restriking current=0)
- The capacitor C_L at the voltage $-3e_{max}$.



At the instant P

- The system voltage reaches its positive maximum.(point T)
 - Voltage across the gap becomes $4e_{\max}$.
 - The capacitive current reaches zero again and there may be an interruption.
 - The transient voltage oscillates between $-3e_{\max}$ and $+5e_{\max}$. (point P—Q)
- ✓ Thus voltage across the gap goes on increasing



DC CIRCUIT BREAKING

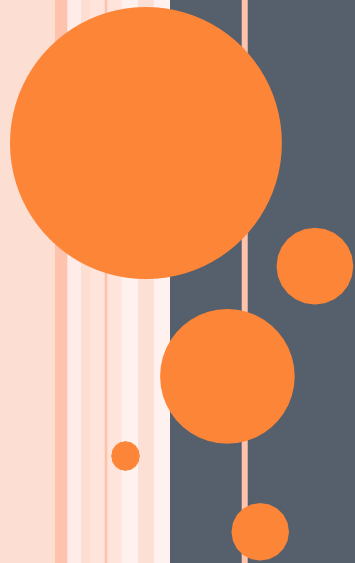

How is dc breaking done?

The contacts of the DC breaker separate and the arc is transferred from contacts to the runners where it rises upwards and extinguishes on its own.



Drawbacks of HVDC circuit breaking

- The amount of **energy** to be **dissipated** during the short interval of breaking is **very high** as compared to the conventional a.c circuit breakers
- The natural zero current does not occur as in the case of a.c cb, resistance switching and the efficient cooling by forcing the liquid or air blast are used to **dissipate the high amount of energy.**



SIMPLE D.C CIRCUIT

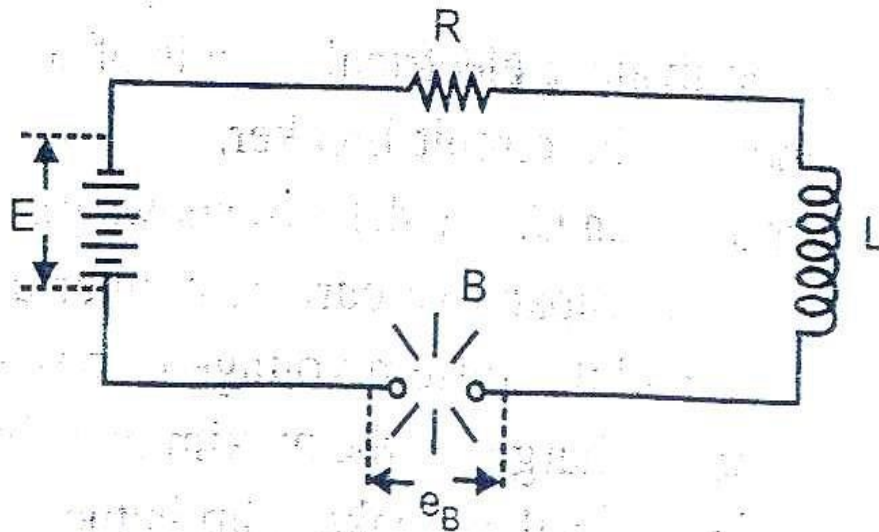

16 An inductive d.c circuit showing the burn

- $B \longrightarrow$ circuit breaker.
- Assuming CB ~~is~~ breaks the current I
($=E/R$)



ARC CHARACTERISTICS

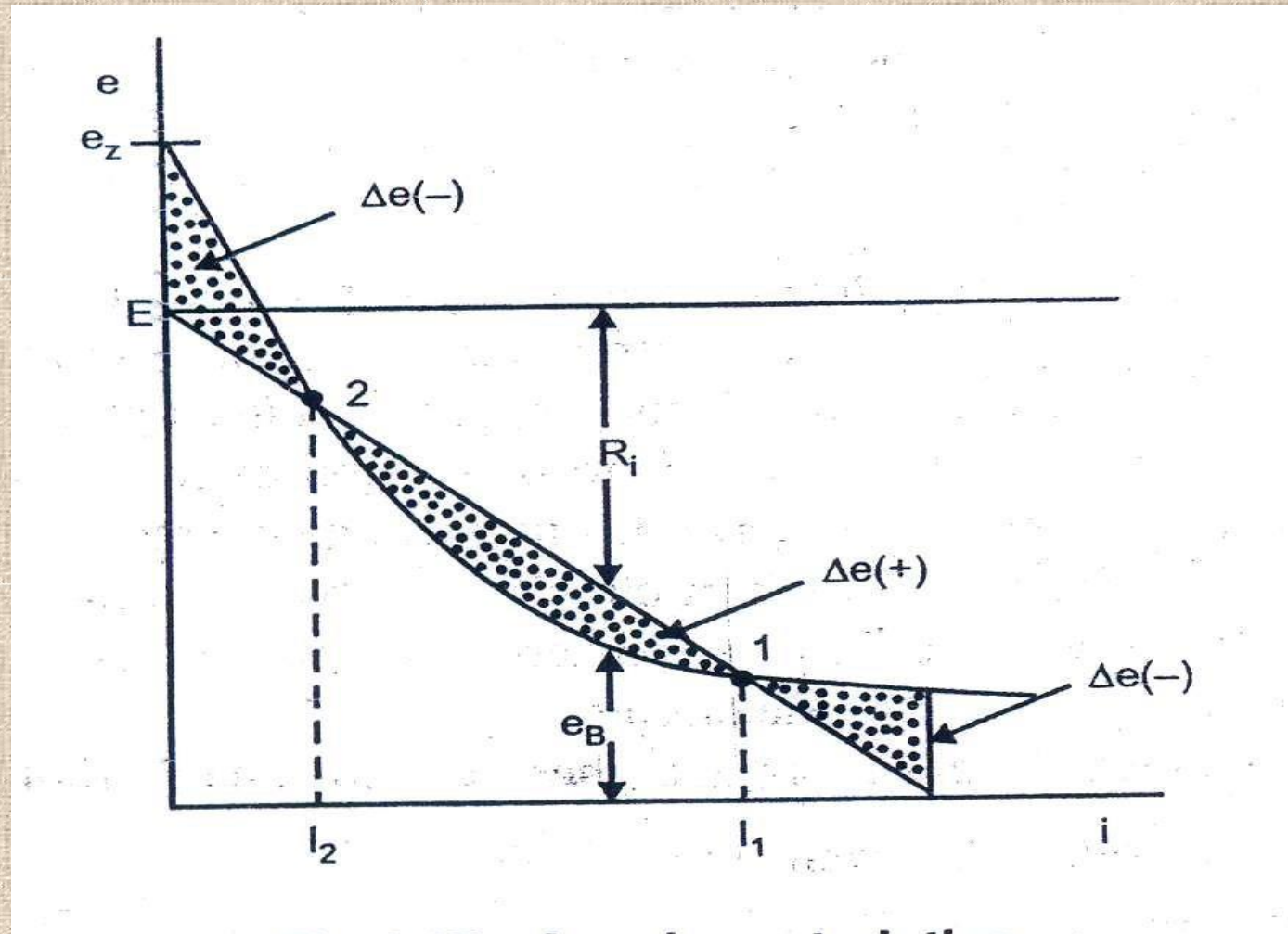

○ The diff equn of the ckt is,

$$L(di/dt) + Ri + eb = E$$

$$\begin{array}{l} \longrightarrow \\ \longrightarrow \end{array} L(di/dt) = (E - Ri) - eb(i) = \Delta e$$

➤ Δe negative:

Current will decrease

➤ Δe positive:

Increase the current



Basic requirement

- Progressive lengthening of arc is a basic requirement of dc circuit breakers.



In designing an HVDC circuit breaker there are three main problems to be solved

- How to produce a current zero?
- How to prevent restriking?
- How to dissipate the stored energy?

Producing current zero

- This approach involves changing the form of arc current by commutation principle
- Quenching gear of well proven HVAC ckt breaker
- Principle of oscillatory circuit



Prevention of restrikes

- To produce a good ionizing arc the space between two walls of arc chute can be narrowed to restrict the arc
- At the same time it can be broken into number of arcs by inserting a grating of vertical metal plane

Dissipation of stored energy

- A protective spark gap can be used across the CB to reduce the size of the commuting capacitor.
- It will keep the abnormal voltage produced at the switching time below the undesired level
- By means of high frequency currents the spark gap acts as an energy dissipating device

