

## BASIC TERMS AND DEFINITIONS:

Power system	Power engineering is also called power systems engineering. It is a subfield of electrical engineering that deals with the generation, transmission, distribution and utilization of electric power, and the electrical apparatus connected to such systems.
Distribution System	Electric power distribution is the final stage in the delivery of electric power; it carries electricity from the transmission system to individual consumers.
Electric supply	Electric power is the rate, per unit time, at which electrical energy is transferred by an electric circuit. The SI unit of power is the watt, one joule per second. Electric power is usually produced by electric generators, but can also be supplied by sources such as electric batteries.
Electrical Network	An electrical network is an interconnection of electrical components (e.g. batteries, resistors, inductors, capacitors, switches) or a model of such an interconnection, consisting of electrical elements (e.g. voltage sources, current sources, resistances, inductances, capacitances).
Connected load	Total Connected Load (TCL) is the mechanical and electrical load (in kW) that will be connected (or to consumed) for that particular area
Demand or Load	The amount of electricity being used at any given moment by a single customer, or by a group of customers. The total demand on a given system is the sum of all of the individual demands on that system occurring at the same moment. The peak demand is the highest demand occurring within a given span of time, usually a season or a year. The peak demand that a transmission or distribution system must carry sets the minimum requirement for its capacity (see also the definition for energy).
Maximum demand	Maximum demand is the highest level of electrical demand monitored in a particular period usually for a month period.
Electric supply	Electric power is the rate, per unit time, at which electrical energy is transferred by an electric circuit. The SI unit of power is the watt, one joule per second. Electric power is usually produced by electric generators, but can also be supplied by sources such as electric batteries.
Base load	A base load power plant is an electric generation plant that is expected to operate in most hours of the year.
Distribution	Distribution means to spread the product throughout the marketplace such that a large number of people can buy it.

Load Model	A load model in this matter is a mathematical representation of the relationship between power and voltage, where the power is either active or reactive and the output from the model. The voltage (magnitude and/or frequency) is the input to the model.
Coincidence factor	Coincidence factor is the ratio of the coincident, maximum demand or two or more loads to the sum of their non coincident maximum demand for a given period; the reciprocal of the diversity factor, and is always less than or equal to one.
contribution factor	The contribution factor is the percentage of end user revenue that will be contributed to the universal service fund to support the universal service programs, as established by the FCC. The contribution factor changes every quarter.
Load-loss factor	Load-loss factor (LLF) is a factor which when multiplied by energy lost at time of peak and the number of load periods will give overall average energy lost. It is calculated as the ratio of the average load loss to the peak load loss. For electricity utilities, expect about 0.03
Residential Load	the term residential use or residential load means “all usual residential, apartment, seasonal dwelling and farm electrical loads or uses, but only the first four hundred horsepower during any monthly billing period of farm irrigation and pumping for any farm.”
Domestic Load	The domestic load is defined as the total energy consumed by the electrical appliances in the household work. It depends on the living standard, weather and type of residence. The domestic loads mainly consist of lights, fan, refrigerator, air conditioners, mixer, grinder, heater, ovens, small pumping, motor, etc. The domestic load consume very little power and also independent from frequency. This load largely consists of lighting, cooling or heating.
Commercial Load	Commercial load mainly consist of lightning of shops, offices, advertisements, etc., Fans, Heating, Air conditioning and many other electrical appliances used in establishments such as market restaurants, etc. are considered as a commercial load.
Industrial Loads	Industrial load consists of small-scale industries, medium scale industries, large scale industries, heavy industries and cottage industries. The induction motor forms a high proportion of the composite load. The industrial loads are the composite load. The composite load is a function of frequency and voltage and its form a major part of the system load.
Agriculture Loads	This type of load is mainly motor pumps-sets load for irrigation purposes. The load factor of this load is very small e.g. 0.15 – 0.20.

## Concepts

### Concepts Introduction to Distribution Systems:

The electric utility industry was born in 1882 when the first electric power station, Pearl Street Electric Station in New York City, went into operation.

In general, the definition of an electric power system includes a generating, a transmission, and a distribution system. The economic importance of the distribution system is very high, and the amount of investment involved dictate careful planning, design, construction, and operation. The objective distribution system planning is to assure that the growing demand for electricity in terms of increasing growth rates and high load densities can be satisfied in an optimum way by additional distribution Systems from the secondary conductors through the bulk power substations, which are both technically adequate and reasonably economical.

### Factors Affecting System Planning:

The number and complexity of the considerations affecting system planning appears initially to be staggering. Demands for ever-increasing power capacity, higher distribution voltages, more automation, and greater control sophistication constitute only the beginning of a list of such factors. The planning problem is an attempt to minimize the cost of sub transmission, Substations, feeders, laterals, etc., as well as the cost of losses.

### Load Forecasting:

The load growth of the geographical area served by utility company is the most important factor influencing the expansion of the distribution system. Therefore, forecasting of load increases and system reaction to these increases is essential to the planning process.

There are two common Time scales of importance to Load Forecasting:

1. Long- range with time horizons on the order of 15 or 20 years away, and
2. Short-range, with time horizons of up to 5 years distant.

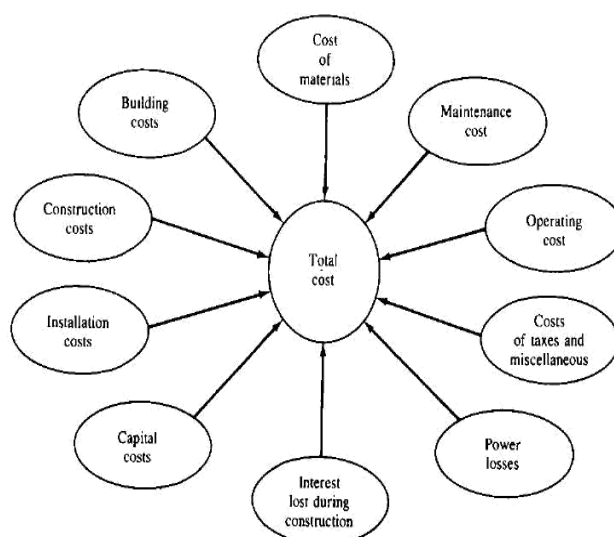

**Figure :Factors affecting load forecast**

## Factors affecting load forecast:

1. Alternative Energy Sources
2. Load density
3. Population growth
4. Historical Data
5. Geographical data

6. Land Use

7. City Plans 
$$P_{LS, av} = \frac{P_{LS, 2} \times t + P_{LS, 1} \times (T - t)}{T}$$

8. Industrial Plans

9. Community development plans

## Load Characteristics:

1. **Demand:** The demand of a system is the load at receiving end over a specified time interval.
2. **Maximum Demand:** The maximum demand of a system is the greater of all the demands within the time interval specified.
3. **Diversified demand (or coincident demand):** It is the demand of the composite group, as a whole, of somewhat unrelated loads over a specified period of time.
4. **Demand factor:** It is the "ratio of the maximum demand of a system to the total connected Load. It is dimension less.  
Demand factor is usually less than 1.0.  
Demand factor = Maximum demand/ Total connected demand
5. **Non-coincident demand:** It is "the sum of the demands of a group of loads with no restrictions on the interval to which each demand is applicable."
6. **Connected load:** It is "the sum of the continuous ratings of the load-consuming apparatus connected to the system"
7. **Utilization factor:** It is "the ratio of the maximum demand of a system to the rated capacity of the system "

$$F_u = \text{Maximum Demand/ rated system capacity}$$

8. **Plant factor:** It is the ratio of the total actual energy produced or served over a designated period of time to the energy that would have been produced or served if the plant (or unit) had operated continuously at maximum rating. It is also known as the capacity factor or the use factor.

Plant Factor = actual energy production (or) served \* time/ maximum plant rating

9. **Load factor** It is "the ratio of the average load over a designated period of time to the peak load occurring on that period"

$$F_{LD} = \text{average load/ peak load}$$

Annual load factor = total annual energy/ annual peak load\*8760

10. **Diversity factor:** It is "the ratio of the sum of the individual maximum demands of the various subdivisions of a system to the maximum demand of the whole system"

$$F_D = \frac{D_1 + D_2 + D_3 + \dots + D_n}{D_g}$$

$$F_D = \frac{\sum_{i=1}^n D_i}{D_g}$$

$$F_D = \frac{\sum_{i=1}^n TCD_i \times DF_i}{D_g}$$

**Load diversity:** It is "the difference between the sum of the peaks of two or more individual loads and the peak of the combined load"

**Contribution factor:** The Contribution factor of the  $i^{\text{th}}$  load to the group maximum demand." It is given in per unit of the individual maximum demand of the  $i^{\text{th}}$  load

$$F_c = \frac{\sum_{i=1}^n c_i \times D_i}{\sum_{i=1}^n D_i}$$

$$D_g = c_1 \times D_1 + c_2 \times D_2 + c_3 \times D_3 + \dots + c_n \times D_n$$

Substituting Equation 2.18 into Equation 2.15,

$$F_c = \frac{c_1 \times D_1 + c_2 \times D_2 + c_3 \times D_3 + \dots + c_n \times D_n}{\sum_{i=1}^n D_i}$$

**Loss factor:** It is " the ratio o f the average power l o s s to the peak-load power loss during a specified period o f time"

**Relationship between Load & loss factors:**

$$F_{LD} = \frac{P_{av}}{P_{max}} = \frac{P_{av}}{P_2}$$

$$P_{av} = \frac{P_2 \times t + P_1 \times (T - t)}{T}$$

$$F_{LD} = \frac{P_2 \times t + P_1 \times (T - t)}{P_2 \times T}$$

$$F_{LD} = \frac{t}{T} + \frac{P_1}{P_2} \times \frac{T - t}{T}$$

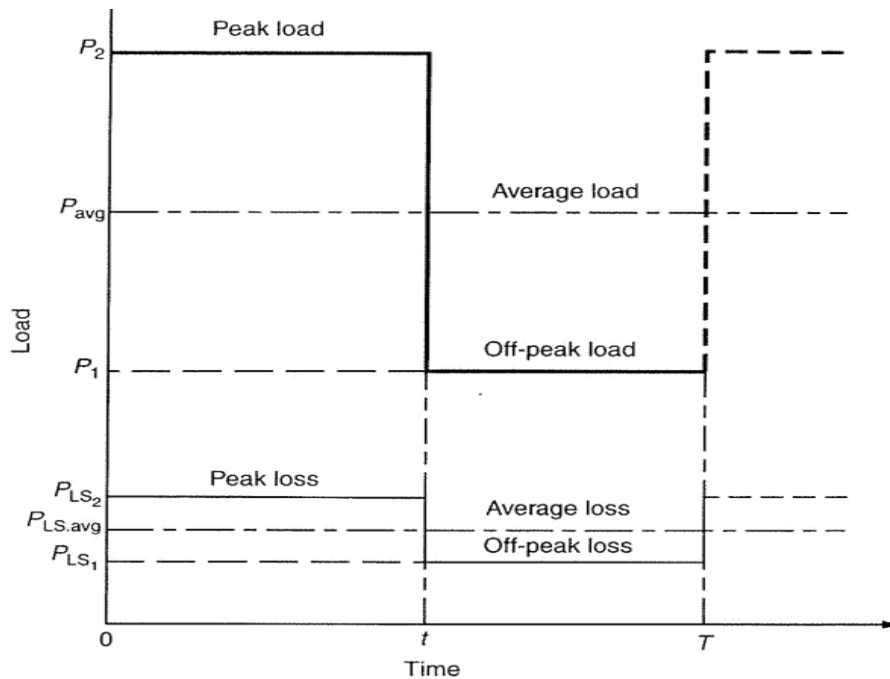
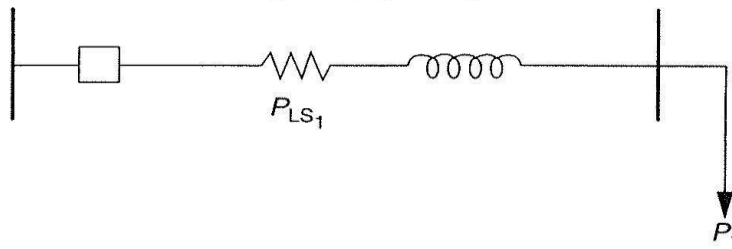

$$F_{LS} = \frac{P_{LS,av}}{P_{LS,max}} = \frac{P_{LS,av}}{P_{LS,2}}$$

Where  $P_{LS,av}$  the average power loss,  $P_{LS,max}$  is the maximum power loss, and  $P_{LS,2}$  is the peak loss at peak load.

$$P_{LS, av} = \frac{P_{LS, 2} \times t + P_{LS, 1} \times (T - t)}{T}$$

Substituting

Where  $P_{LS, avg}$  the average power loss,  $P_{LS, max}$  is the maximum power loss, and  $P_{LS, 2}$  is the peak loss at peak load.

$$F_{LS} = \frac{P_{LS, 2} \times t + P_{LS, 1} \times (T - t)}{P_{LS, 2} \times T},$$

Where  $P_{LS, 1}$  is the off-peak loss at off-peak load,  $t$  is the peak load duration, and  $T - t$  is the off-peak load duration.

The copper losses are the function of the associated loads. Therefore, the off-peak and peak loads can be expressed, respectively, as

$$P_{LS, 1} = k \times P_1^2$$

$$P_{LS, 2} = k \times P_2^2$$

Where  $k$  is a constant. Thus, substituting Equations 2.32 and 2.33 into Equation 2.31, the loss factor can be expressed as

$$F_{LS} = \frac{(k \times P_2^2) \times t + (k \times P_1^2) \times (T - t)}{(k \times P_2^2) \times T}$$

$$F_{LS} = \frac{t}{T} + \left( \frac{P_1}{P_2} \right)^2 \times \frac{T - t}{T}$$

Load factor can be related to loss factor for three different cases

**Case 1:** Off-peak load is zero. Here,  $P_{LS, 1} = 0$

Since  $P_1 = 0$ . Therefore  $F_{LD} = F_{LS} = \frac{t}{T}$ .

Since  $P_2 = 0$ . Therefore

That is, the load factor is equal to the loss factor and they are equal to the  $t/T$  constant

Case 2: Very short lasting peak. Here,  $t \rightarrow 0$

$$\frac{T-t}{T} \rightarrow 1.0;$$

$$F_{LS} \rightarrow (F_{LD})^2$$

That is, the value of the loss factor approaches the value of the load factor squared

Case 3: Load is steady. Here,  $t \rightarrow T$ .

That is, the difference between the peak load and the off-peak load is negligible. For example, if the customer's load is a petrochemical plant, this would be the case

$$F_{LS} \rightarrow F_{LD}$$

That is, the value of the loss factor approaches the value of the load factor. Therefore, in general, the value of the loss factor is

$$F_{LD}^2 < F_{LS} < F_{LD}$$

Therefore, the loss factor cannot be determined directly from the load factor. The reason is that the loss factor is determined from losses as a function of time, which, in turn, is proportional to the time function of the square load

However, Buller and Woodrow developed an approximate formula to relate the loss factor to the load factor as

$$F_{LS} = 0.3 F_{LD} + 0.7 F_{LD}^2$$

Where FLS is the loss factor (pu) and FLD is the load factor (pu).

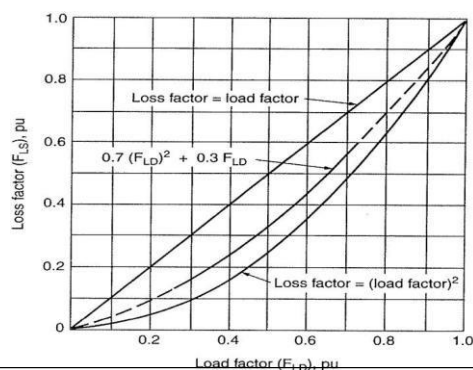



## Electrical Load Definition:

The Electrical Load is The part or component in a circuit that converts electricity into light, heat, or mechanical motion. Examples of loads are a light bulb, resistor, or motor.

another definition:

If an electric circuit has a well-defined output terminal, the circuit connected to this terminal (or its input impedance) is the load.(see fig.1)

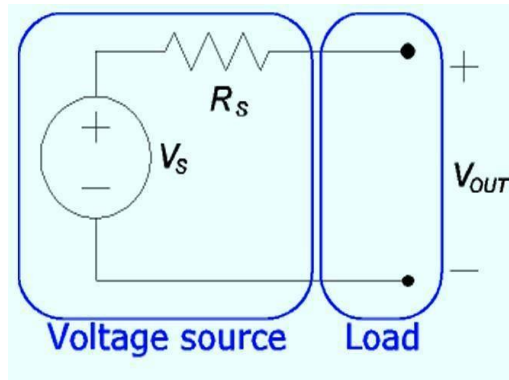

Fig.1

## Electrical Load Classification and Types:

The electrical loads can be classified into various categories according to various factors as follows:

### 1- According To Load Nature-1

Resistive Electrical Loads.

Capacitive Electrical Loads.

Inductive Electrical Loads.

Combination Electrical Loads.

### 2- According To Load Nature-2

Linear Electrical Load.

None-Linear Electrical Load.

### 3- According To Load Function

Lighting Load.

Receptacles / General / Small Appliances Load.

Power Loads.

### 4- According To Load Consumer Category

Residential Electrical Loads (Dwelling Loads).

Commercial Electrical Loads.

Industrial Electrical Loads.

Municipal / Governmental Electrical Loads (Street Lighting, Power Required For Water Supply and Drainage Purposes, Irrigation Loads And Traction Loads).

### 5- According To Load Grouping

Individual Loads (Single Load).

Load Centers (Area Loads).

### 6- According To Load Planning

Existing Electrical Loads.

Future Electrical Loads (Electrical Loads Growth).

New Electrical Loads (Additional Electrical Loads).

7- According To Load Operation Time

Continuous Electrical Loads.

Non-Continuous Electrical Loads.

Duty, Intermittent Electrical Loads.

Duty, Periodic Electrical Loads.

Duty, Short-Time Electrical Loads.

Duty, Varying Electrical Loads.

8- According To Load Importance

Vital Electrical Loads (Life Safety Electrical Loads).

Essential Electrical Loads (Emergency Electrical Loads).

Non-Essential Electrical Loads (Normal Electrical Loads).

9- According To Load /phase distribution

Balanced Electrical Loads.

Non-Balanced Electrical Loads.

Neutral load.

Line to neutral load.

10- According to number of Electrical Loads phases

Single phase Electrical Loads.

Three phase Electrical Loads.

### **Important Questions:**

1. Draw a block diagram in flow chart form for a typical distribution system planning process and explain the techniques for distribution planning.
2. Discuss about different load modelling and its characteristics.
3. Obtain the relation between the load factor and loss factor.
4. Explain the various factors affecting the distribution system planning?
5. What is load? Explain different types of loads with their characteristics?