

Molecular Orbitals



*AN APPROACH TO BONDING IN WHICH ORBITALS
ENCOMPASS THE ENTIRE MOLECULE, RATHER THAN
BEING LOCALIZED BETWEEN ATOMS.*

Molecular Orbitals



Molecular orbitals result from the combination of atomic orbitals.

Since orbitals are wave functions, they can combine either constructively (forming a bonding molecular orbital), or destructively (forming an antibonding molecular orbital).

Molecular Orbitals



Molecular orbitals form when atomic orbitals with similar energies and proper symmetry can overlap.

Atomic orbitals with differing energies or the wrong spatial orientation (orthogonal) do not combine, and are called *non-bonding* orbitals.

Need for MO Theory



Valence bond theory fails to explain the bonding in many simple molecules.

The oxygen molecule has a bond length and strength consistent with a double bond, and it contains two unpaired electrons.

Need for MO Theory



Valence bond theory predicts the double bond, but not the paramagnetism of oxygen.

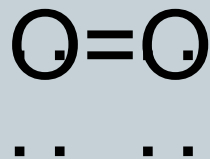

Need for MO Theory



Resonance is another example of the limitations of valence bond theory. Bond lengths and strengths are intermediate between single, double or triple bonds.

Molecular orbital theory is often a better approach to use with molecules that have extended π systems.

Molecular Orbital Theory



In order to simplify things, we'll consider the interaction of the orbitals containing valence electrons to create molecular orbitals.

The wave functions of hydrogen atom A and hydrogen atom B can interact either constructively or destructively.

Molecular Orbital Theory



Constructively:

$$\Psi_{(\sigma)} \text{ or } \Psi_{+} = (1/\sqrt{2}) [\varphi_{(1sa)} + \varphi_{(1sb)}]$$

Destructively:

$$\Psi_{(\sigma^*)} \text{ or } \Psi_{-} = (1/\sqrt{2}) [\varphi_{(1sa)} - \varphi_{(1sb)}]$$

Molecular Orbital Theory

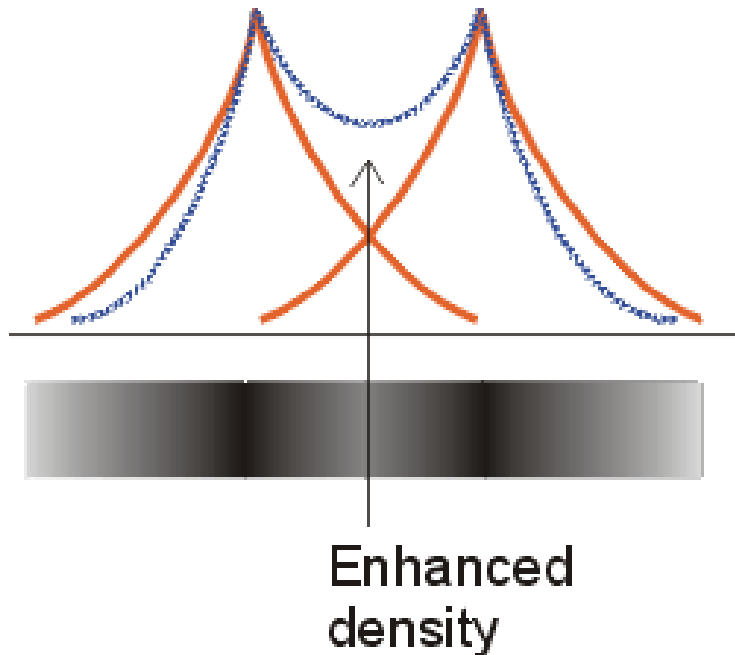

The bonding orbital results in increased electron density between the two nuclei, and is of lower energy than the two separate atomic orbitals.

Molecular Orbital Theory

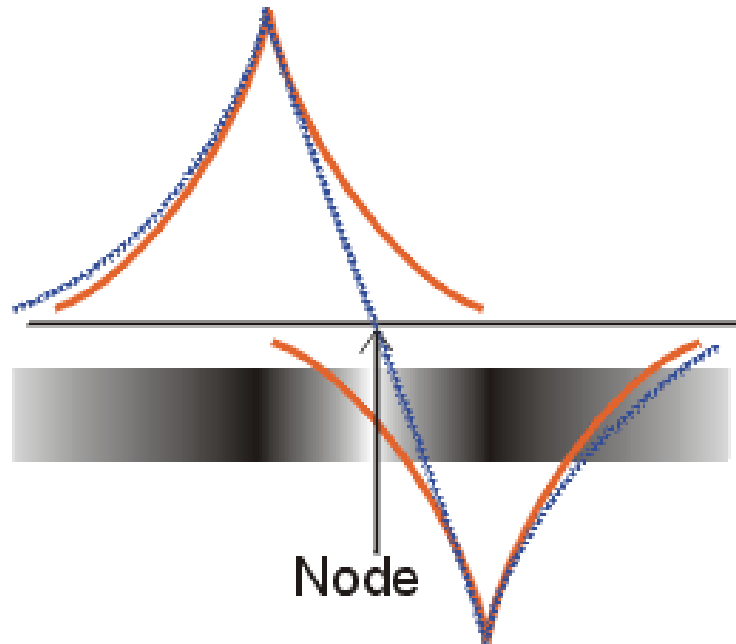

The antibonding orbital results in a node between the two nuclei, and is of greater energy than the two separate atomic orbitals.

Molecular Orbital Theory

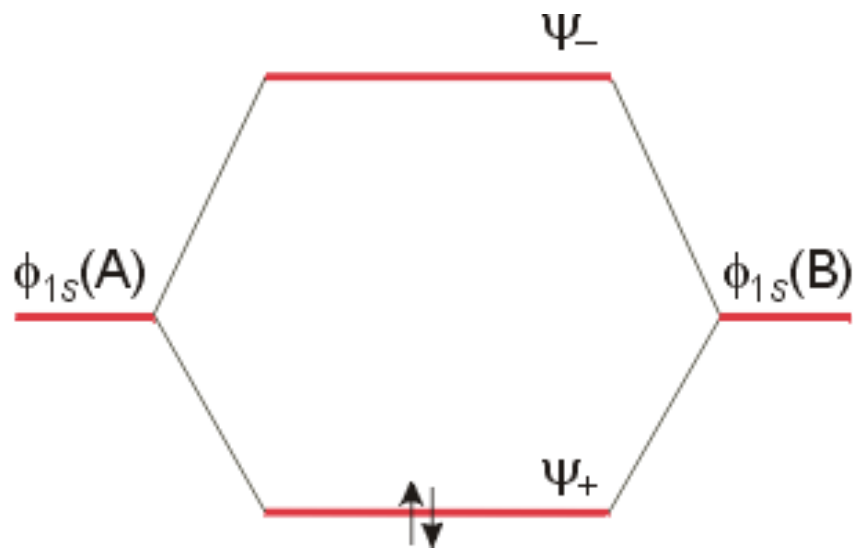

The result is an energy level diagram with the bonding orbital occupied by a pair of electrons. The filling of the lower molecular orbital indicates that the molecule is stable compared to the two individual atoms.

Molecular Orbital Theory

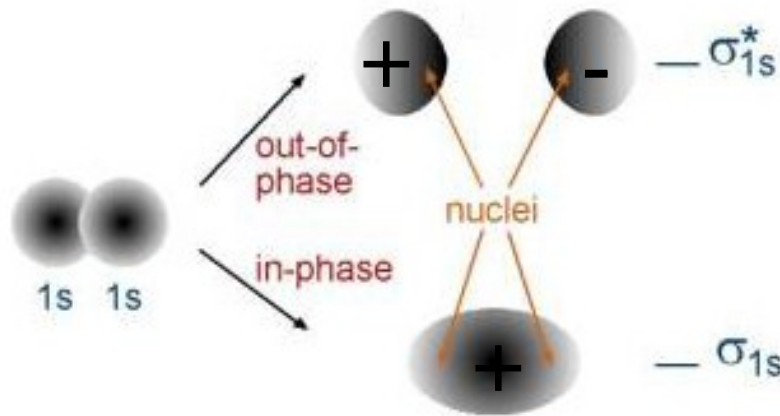

The bonding orbital is sometimes given the notation σ_g , where the *g* stands for *gerade*, or symmetric with respect to a center of inversion.

The signs on the molecular orbitals indicate the sign of the wave function, not ionic charge.

Molecular Orbital Theory

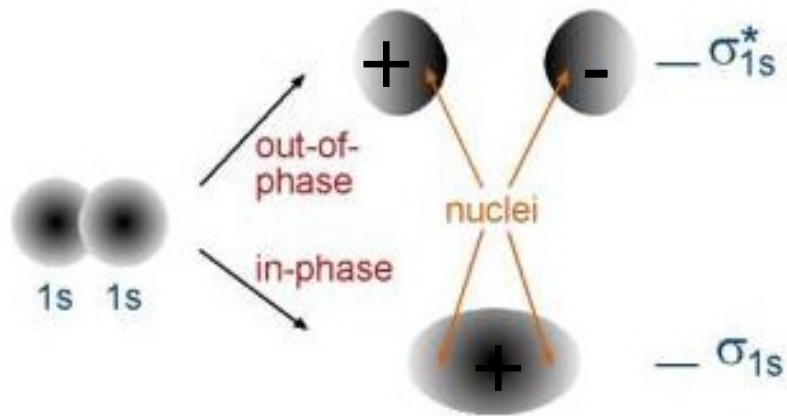

The anti-bonding orbital is sometimes given the notation σ_u , where the u stands for *ungerade*, or asymmetric with respect to a center of

~~inversion.~~ The signs on the molecular orbitals indicate the sign of the wave function, not ionic charge.

Rules for Combining Atomic Orbitals



1. The number of molecular orbitals = the number of atomic orbitals combined.
2. The strength of the bond depends upon the degree of orbital overlap.

Experimental Evidence



Photoelectron spectroscopy (PES) is a technique in which a beam of ultraviolet light with an energy of 21 eV is used to irradiate molecules.

The energy is high enough to eject electrons. The kinetic energy of the emitted electrons is measured, and used to determine the energy level of the electron.

Experimental Evidence

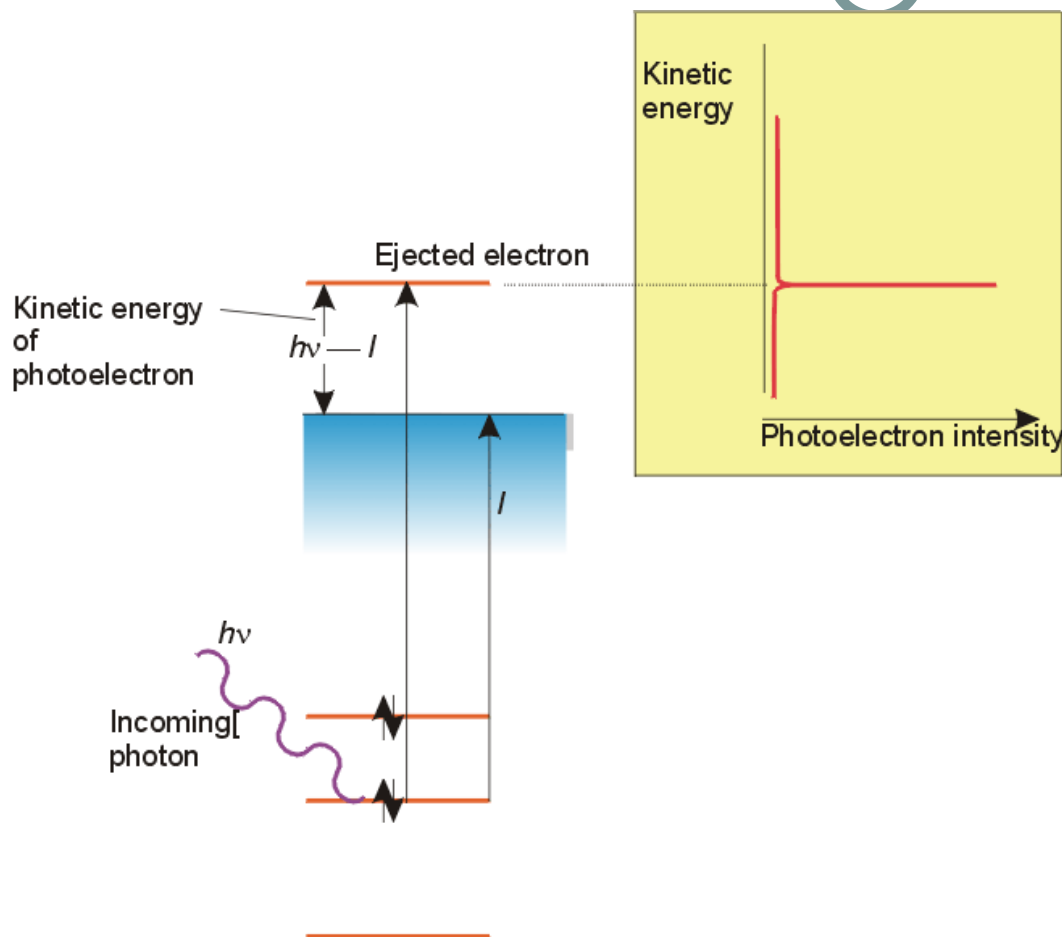

The technique allows for the measurement of specific ionization energies (I). Each ionization energy represents the removal of an electron from a specific molecular orbital.

Experimental Evidence

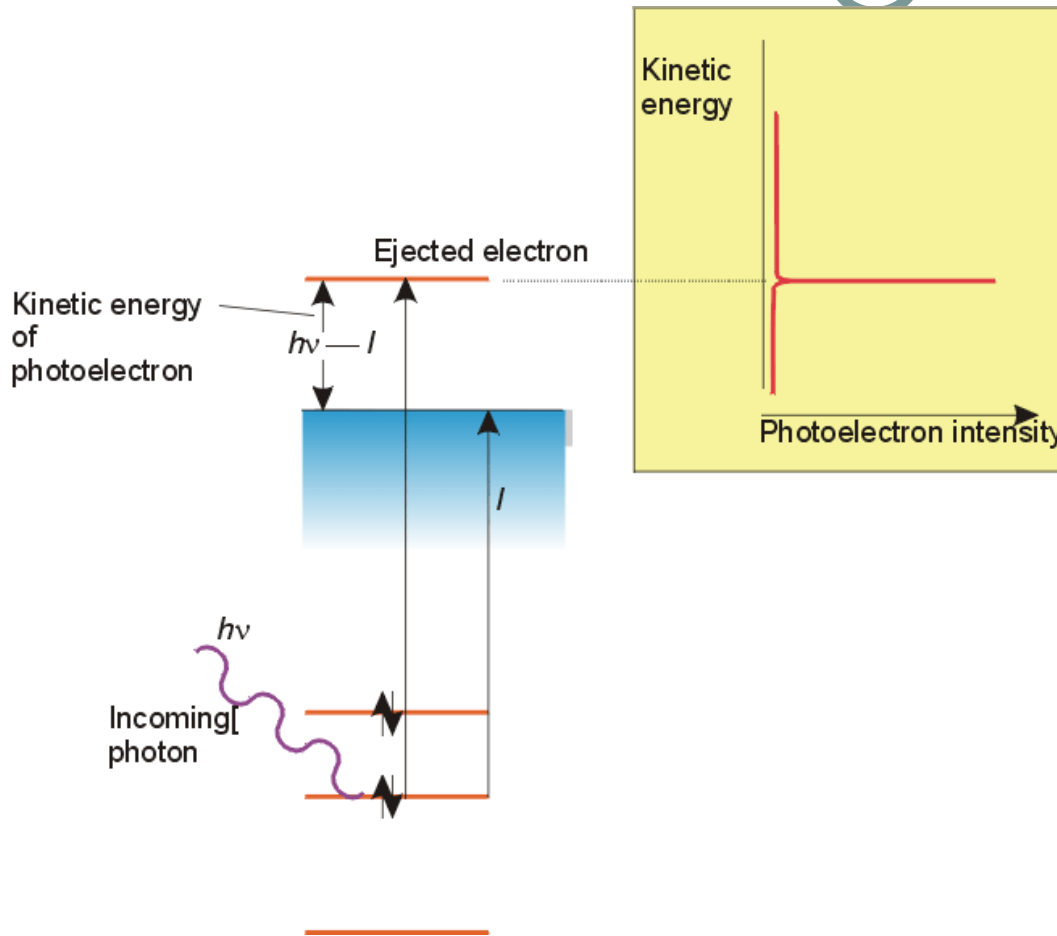

Electrons in lower energy levels require more energy to be removed, and are ejected with less kinetic energy.

$$h\nu_0 = I + E_{\text{kinetic}}$$

Period 2 Diatomic Molecules



For the second period, assume that, due to a better energy match, s orbitals combine with s orbitals, and p orbitals combine with p orbitals.

The symmetry of p orbitals permits end-on-end overlap along the bond axis, or side-by-side overlap around, but not along, the internuclear axis.

MOs using p orbitals

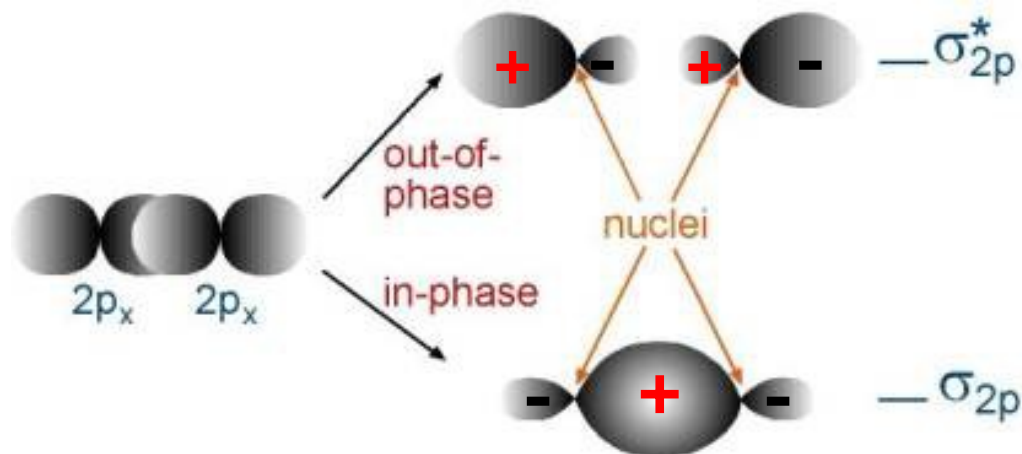

With the x axis as the bond axis, the p_x orbitals may combine constructively or destructively. The result is a σ bonding orbital and a σ anti-bonding orbital.

MOs using p orbitals

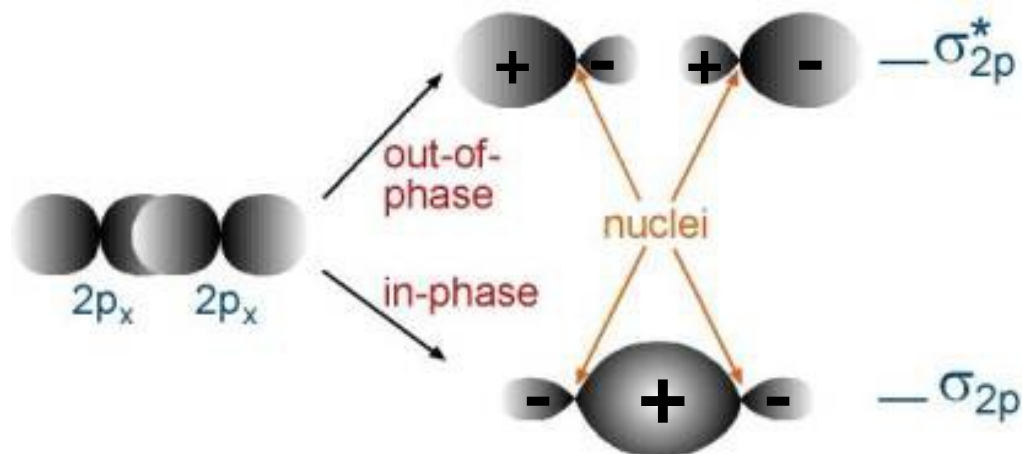

The designation σ indicates symmetric electron density around the internuclear (x) axis. The + and - signs indicate the sign of the wave function, and not electrical charges.

MOs using p orbitals

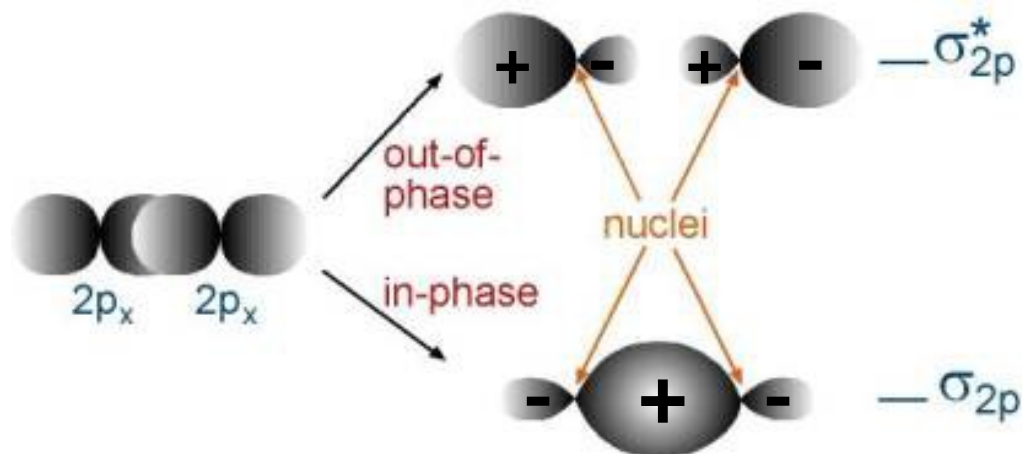

Some texts will use the symmetry designations of g (gerade) or u (ungerade) instead of indicating bonding or anti-bonding.

MOs using p orbitals

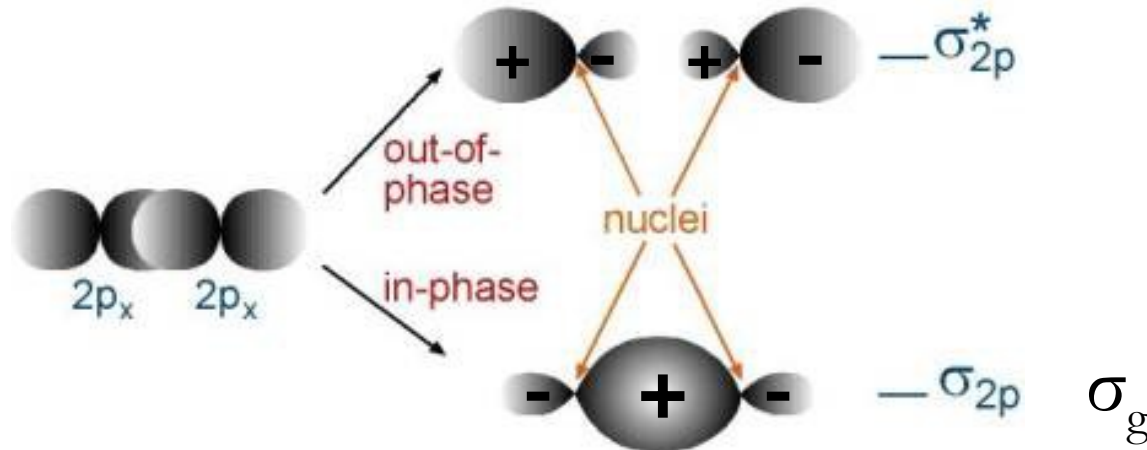

For these orbitals, the bonding orbital is *gerade*, or symmetric around the bond axis.

MOs using p orbitals

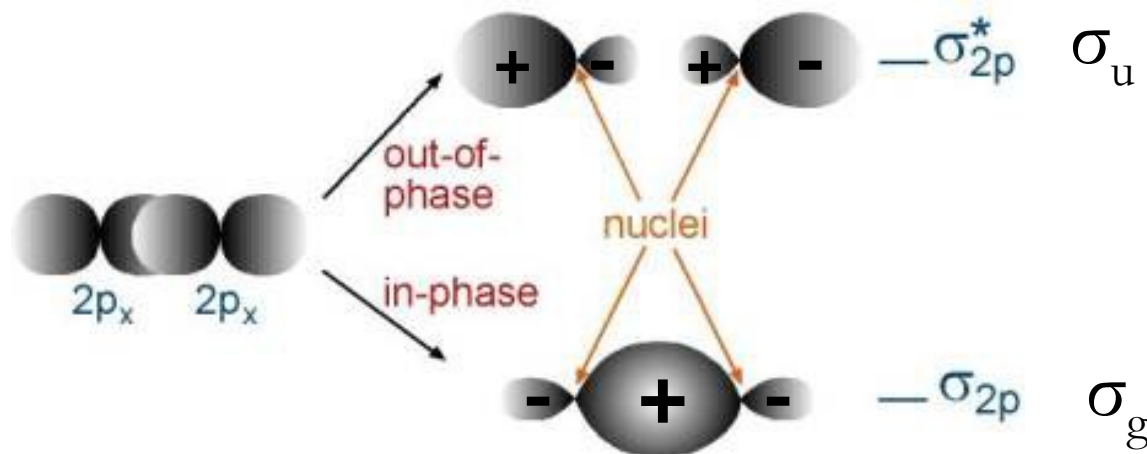

For these orbitals, the anti-bonding orbital is asymmetric about the bond axis, and is designated as σ_u . Note that the designations of u or g do not correlate with bonding or anti-bonding.

π Molecular Orbitals

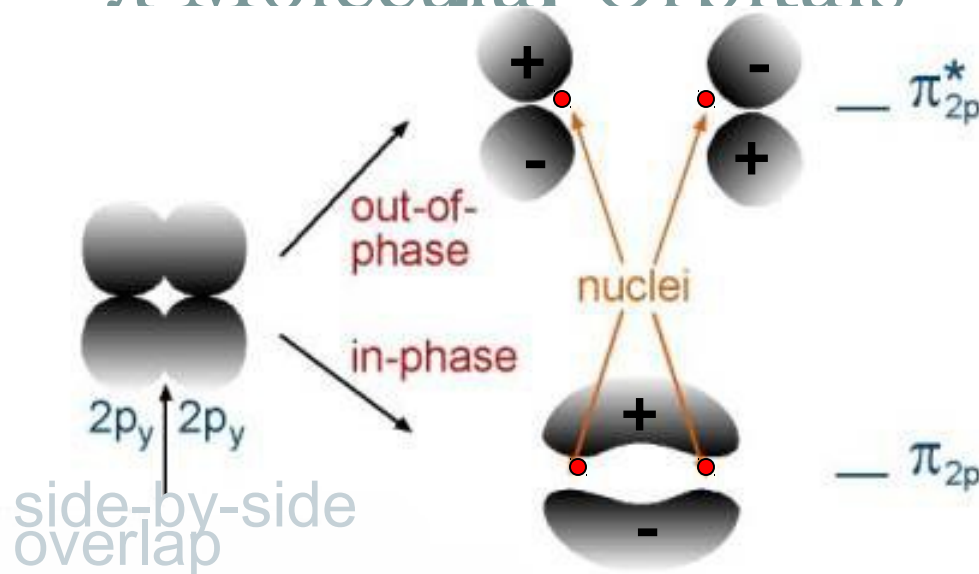

The orbital overlap side-by-side is less than that of overlap along the bond axis (end-on-end). As a result, the bonding orbital will be higher in energy than the previous example.

π Molecular Orbitals

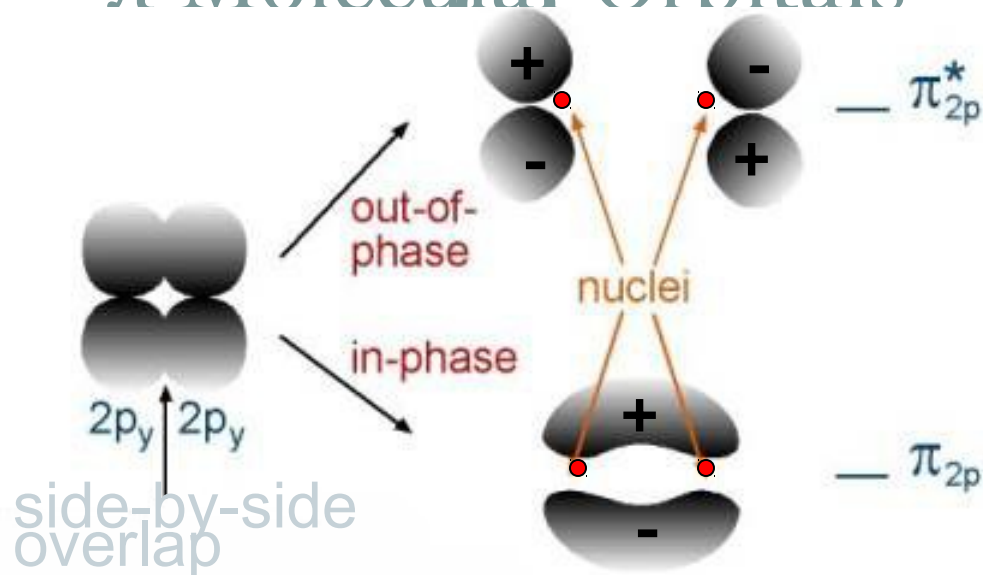

π orbitals are asymmetric with respect to the bond axis. There is electron density surrounding the bond axis, with a node along the internuclear axis.

π Molecular Orbitals

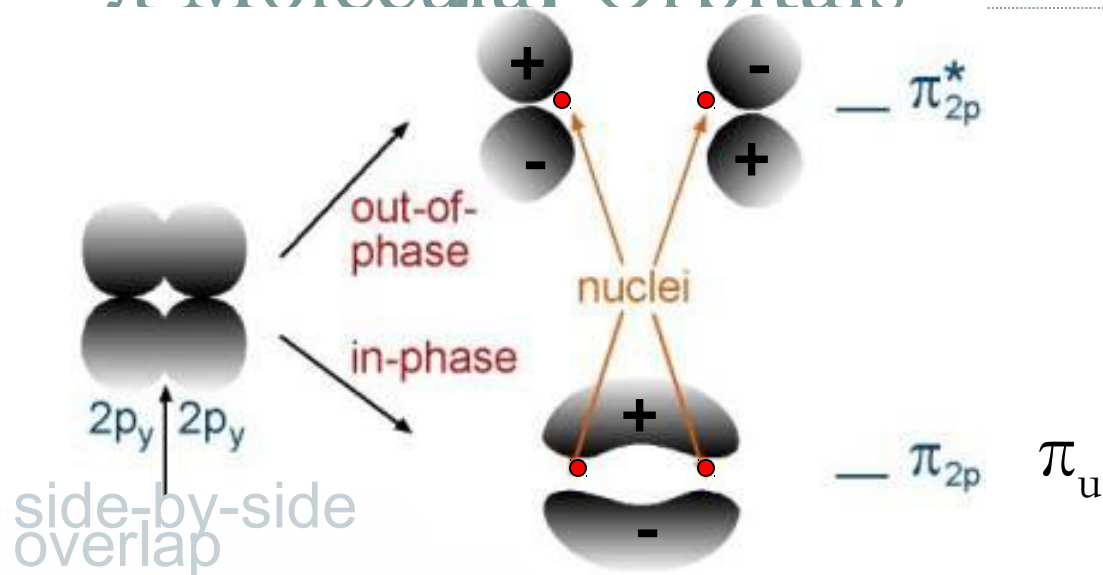

Some texts use the subscripts g and u instead of bonding and anti-bonding. In this example, the bonding orbital is ungerade, or asymmetric about a center of symmetry.

π Molecular Orbitals

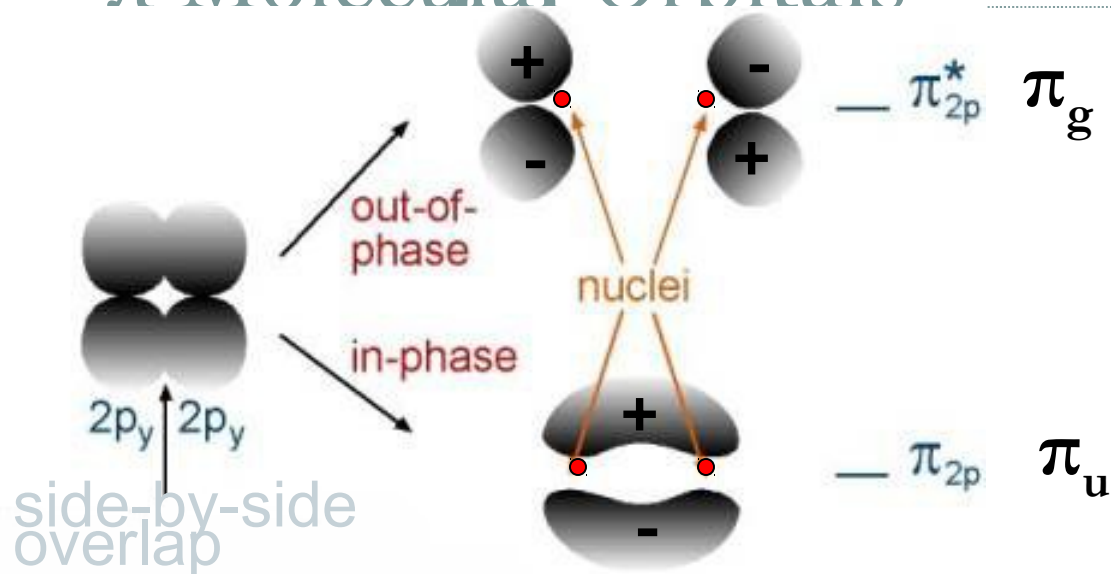

The anti-bonding orbital is *gerade*, or symmetric about a center of symmetry.

Molecular Orbital Diagram

This is a molecular orbital energy level diagram for the p orbitals. Note that the σ bonding orbital is lowest in energy due to the greater overlap end-on-end.

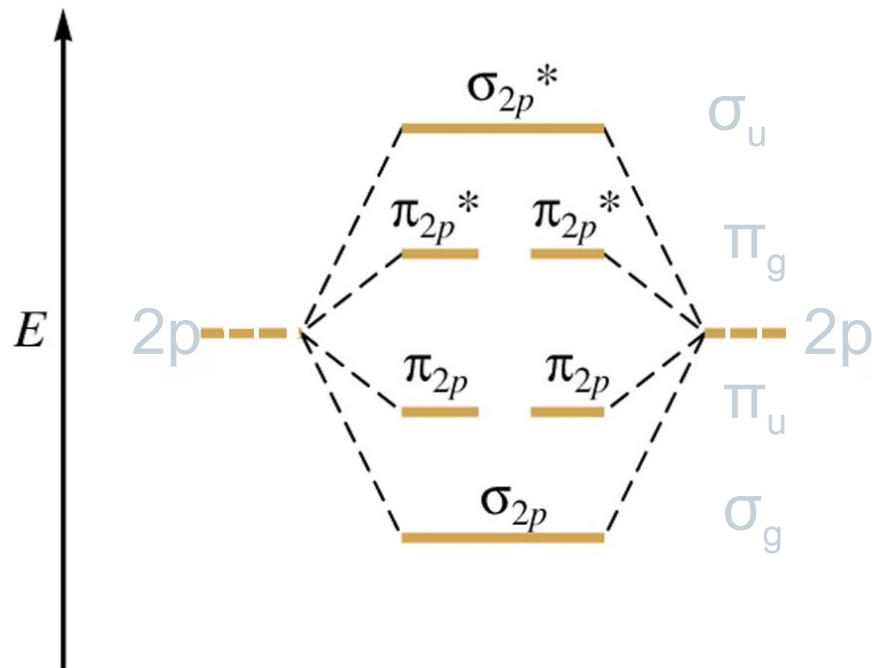

Molecular Orbital Diagram

The alternate notation is provided on the right side of the energy level diagram.

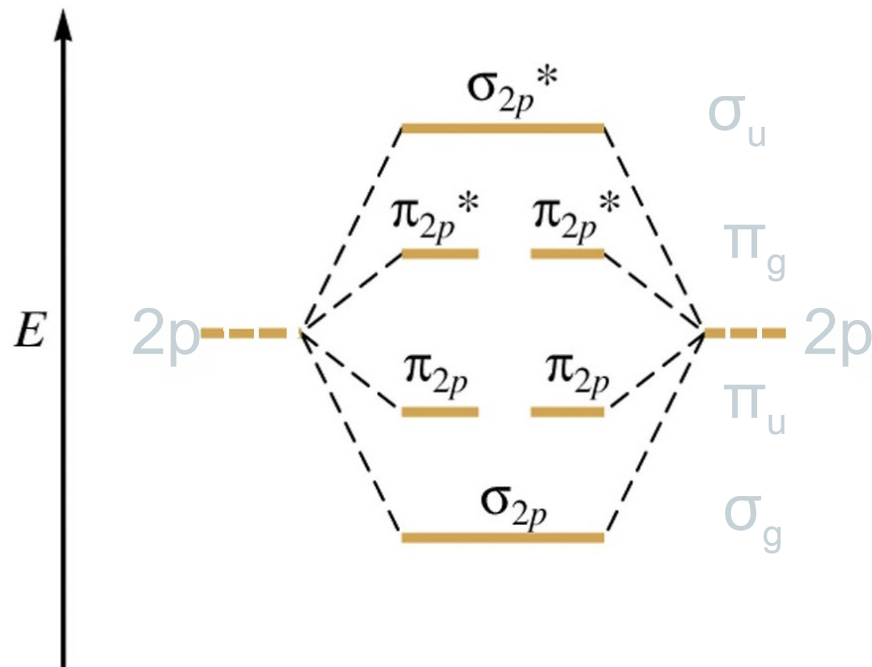

Molecular Orbital Diagrams



1. Electrons preferentially occupy molecular orbitals that are lower in energy.
2. Molecular orbitals may be empty, or contain one or two electrons.
3. If two electrons occupy the same molecular orbital, they must be spin paired.
4. When occupying degenerate molecular orbitals, electrons occupy separate orbitals with parallel spins before pairing.

Molecular Orbital Diagrams



Although molecular orbitals form from inner (core) electrons as well as valence electrons, many molecular orbital diagrams include only the valence level.

Molecular Orbital Diagrams

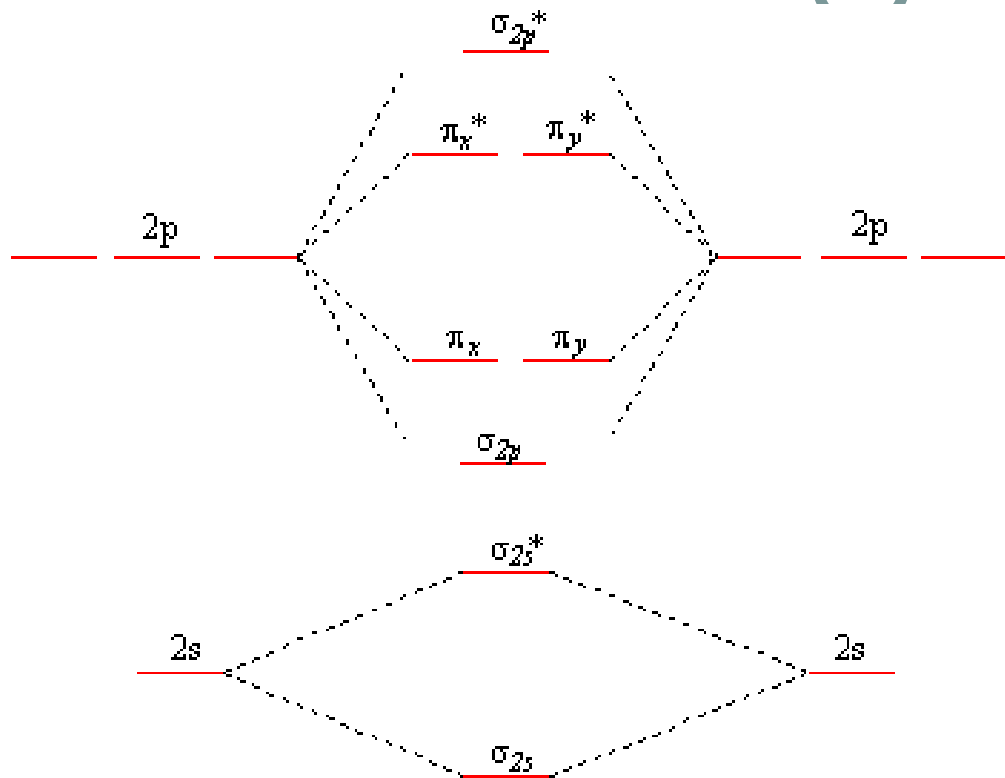

For O_2 , there will be a total of 12 valence electrons that must be placed in the diagram.

Molecular Orbital Diagrams

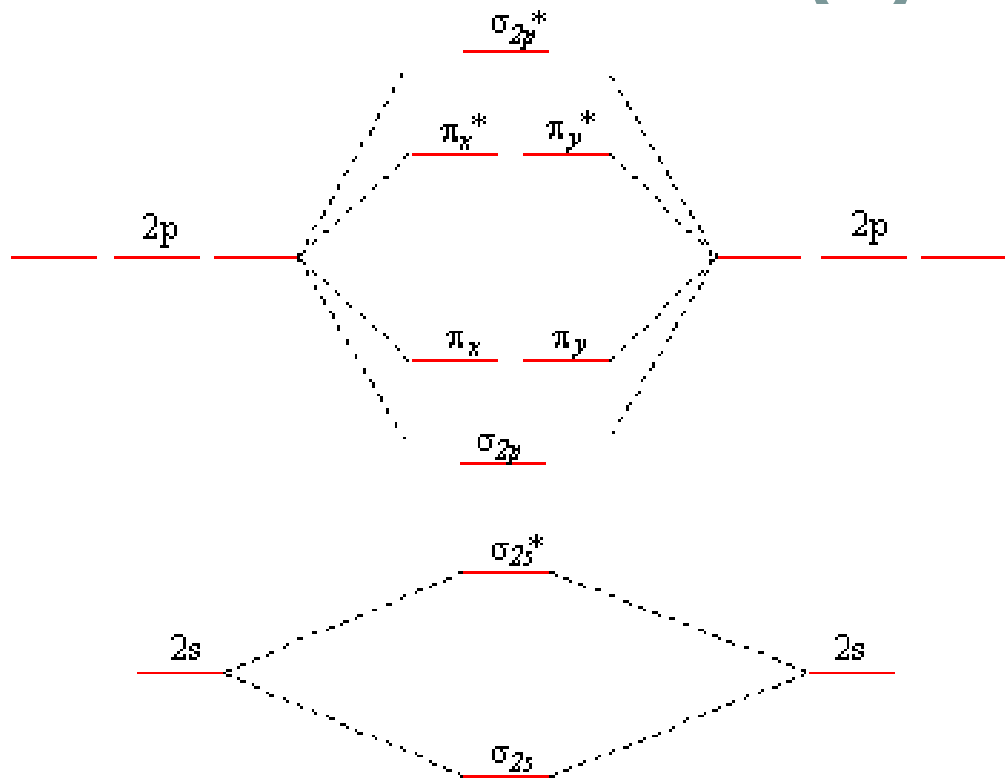

For O_2 , there will be a total of 12 valence electrons that must be placed in the diagram.

Molecular Orbital Diagrams

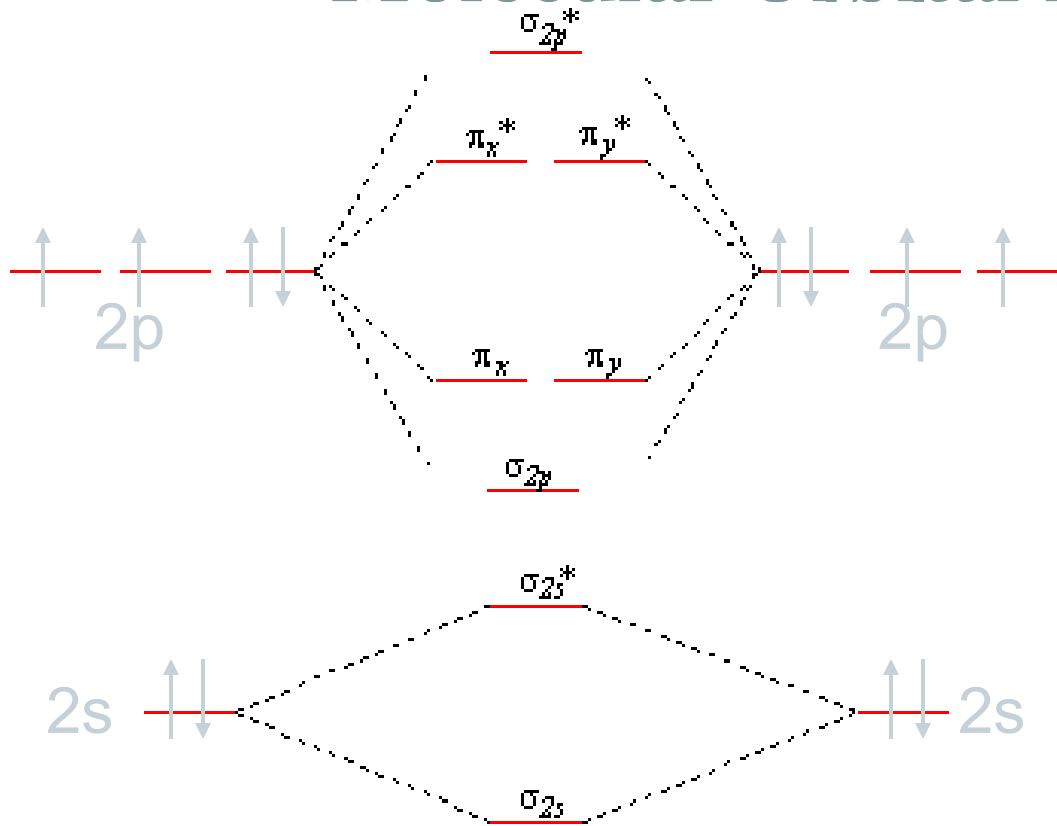

For O_2 , there will be a total of 12 valence electrons that must be placed in the diagram.

MO Diagram for O₂

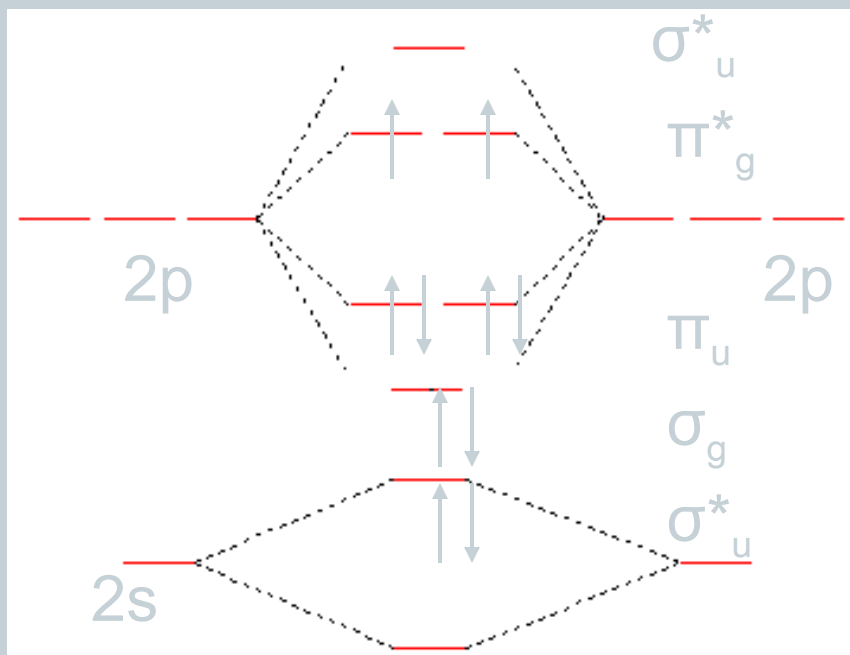

The molecular orbital diagram for oxygen shows two unpaired electrons, consistent with experimental data.

Bond Order



Bond order is an indicator of the bond strength and length. A bond order of 1 is equivalent to a single bond. Fractional bond orders are possible.

$$\text{The bond order of the molecule} = \frac{(\# \text{ e}^- \text{ in bonding orbitals})}{2} - \frac{(\# \text{ e}^- \text{ in anti-bonding orbitals})}{2}$$

MO Diagram for O₂

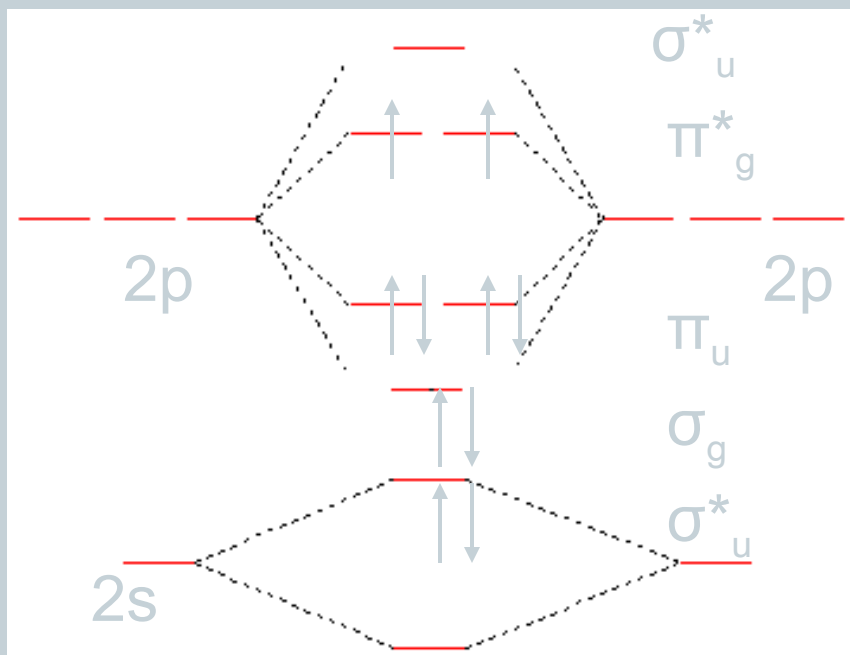

The bond order of O₂ is:

$$\frac{8-4}{2} = 2$$

This is consistent with a double bond.

MO Diagram for O₂

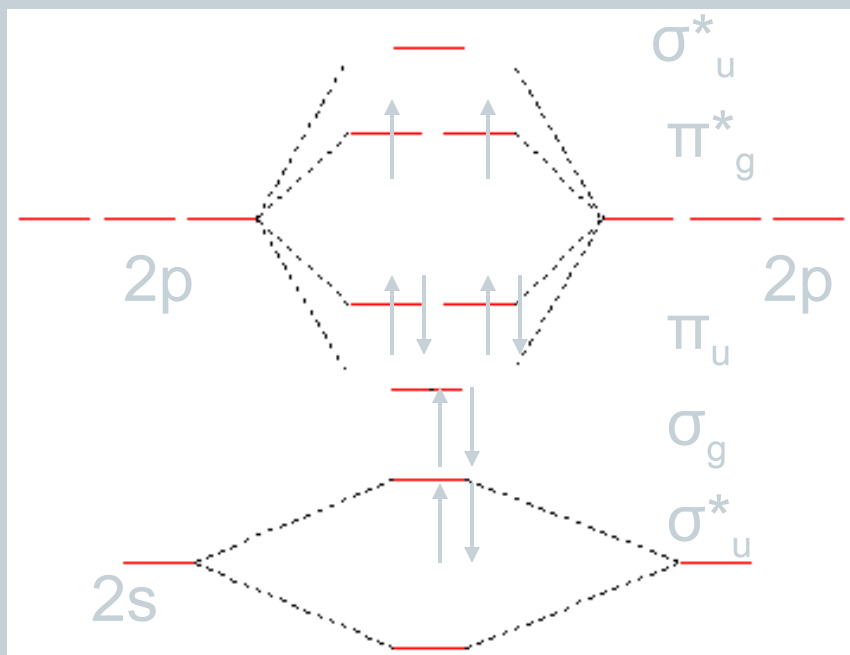

This energy level diagram works well for atoms in which the 2s and 2p levels are fairly far apart. These are the elements at the right of the table: O, F and Ne.

Experimental Evidence



Oxygen is paramagnetic, consistent with having two unpaired electrons. In addition, *photoelectron spectroscopy* (PES) can be used for determining orbital energies in molecules. The molecule is bombarded with UV or X-rays to remove an electron from the molecule. The kinetic energy of the emitted electron is measured and subtracted from the incident radiation to determine the binding energy of the electron.

Photoelectron Spectroscopy



The result is a spectrum of absorptions which are correlated to the molecular orbitals of the molecule. In addition, electrons ejected from bonding orbitals show more vibrational energy levels than electrons emitted from anti-bonding or non-bonding orbitals.

Oxygen

$\pi_g^*(2p)$

O_2^+ Terms

$2\Pi_g$

$\pi_u(2p)$

$4\Pi_u$

$2\Pi_u$

$\sigma_g(2p)$

$4\Sigma_g^-$

$\sigma_u^*(2s)$

$2\Sigma_g^-$

E(eV)



MO diagram for Li through N



The elements on the left side of period 2 have a fairly small energy gap between the 2s and 2p orbitals. As a result, interaction between s and p orbitals is possible. This can be viewed in different ways.

MO diagram for Li through N

In some approaches, the s orbital on one atom interacts with the p orbital on another. The interaction can be constructive or destructive.

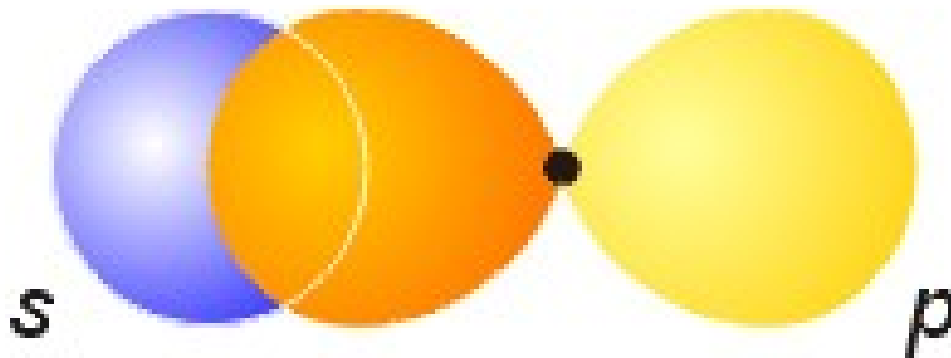

MO diagram for Li through N



In another approach, the s and p orbitals on the same atom interact in what is called *orbital mixing*.

Either approach yields the same result. The σ bonding and anti-bonding orbitals are raised in energy due to the interaction with a *p* orbital.

MO diagram for Li through N

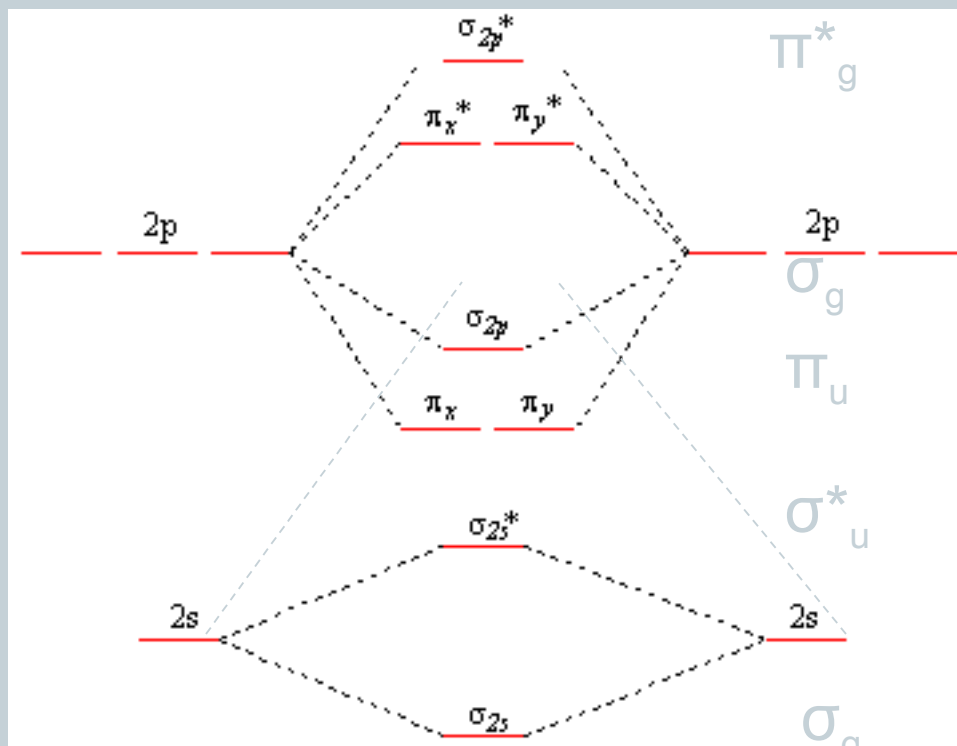

MO diagram for N₂

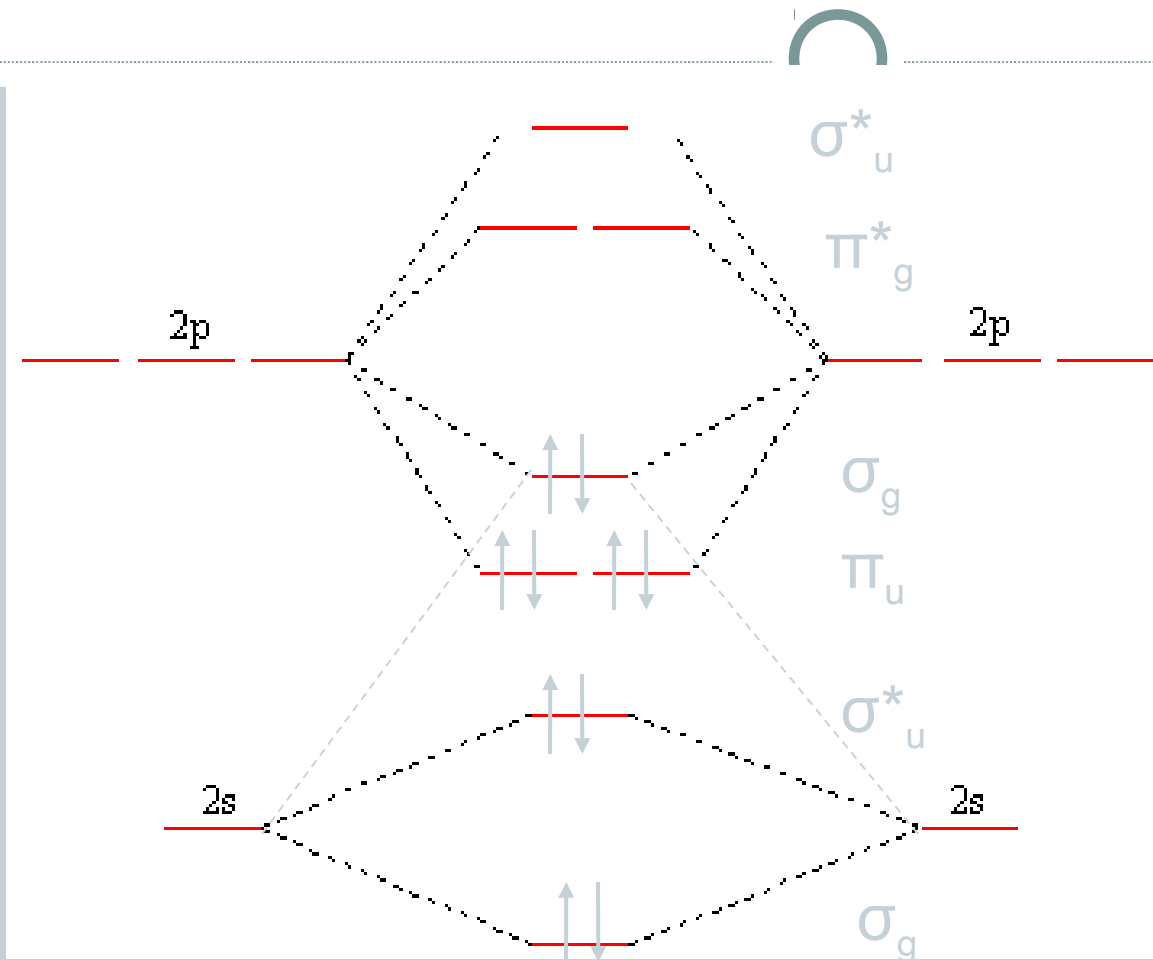

N₂ has 10
valence
electrons.

Experimental Evidence

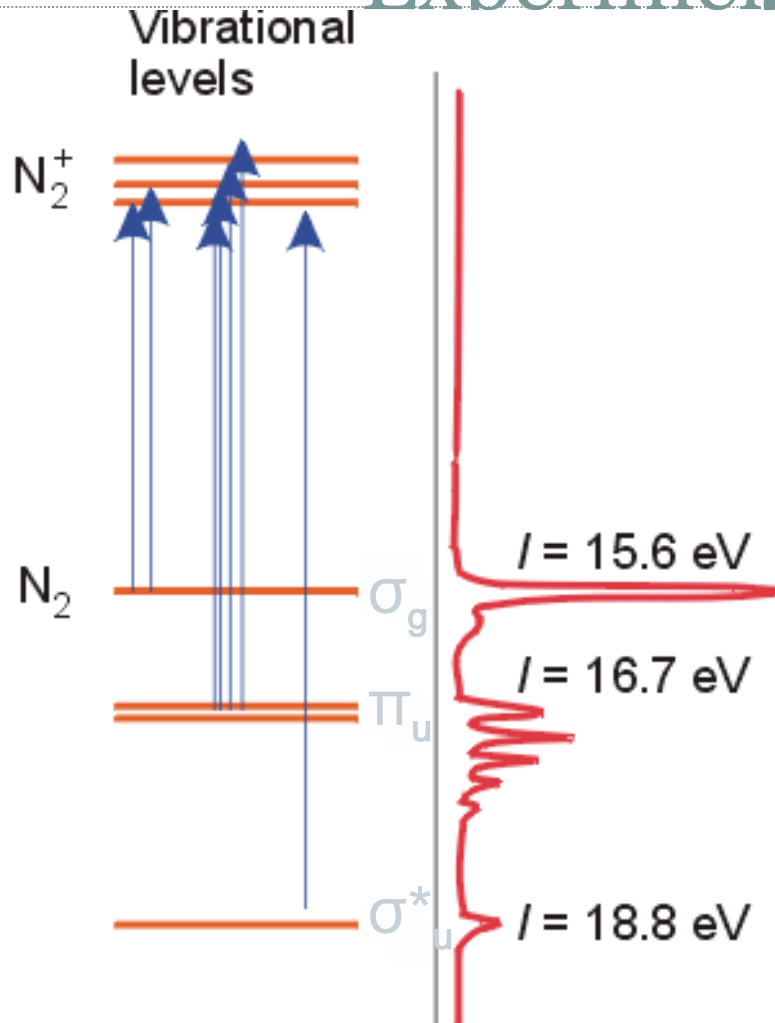

The photoelectronic spectrum of nitrogen is consistent with a molecular orbital approach.

Electrons emitted from bonding orbitals show vibrational excitations.

Experimental Evidence

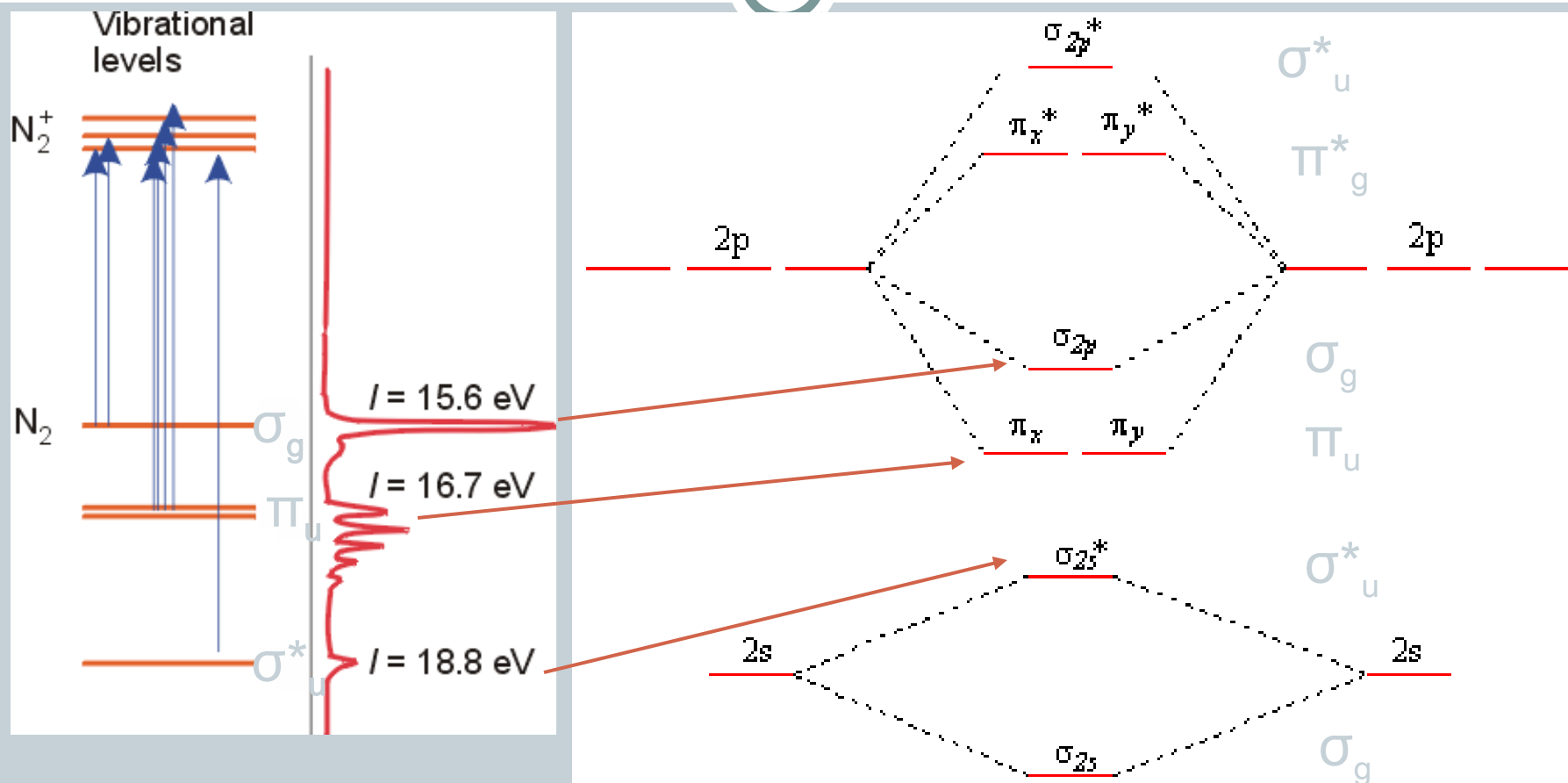

Heteronuclear Diatomic Molecules



The more electronegative atom will have orbitals of lower energy, and therefore contribute more to the bonding orbitals.

The less electronegative atom has orbitals of higher energy, and contributes more to the anti-bonding orbitals.

Rules for Combining Atomic Orbitals



For heteronuclear molecules:

1. The bonding orbital(s) will reside predominantly on the atom of lower orbital energy (the more electronegative atom).
2. The anti-bonding orbital(s) will reside predominantly on the atom with greater orbital energy (the less electronegative atom).

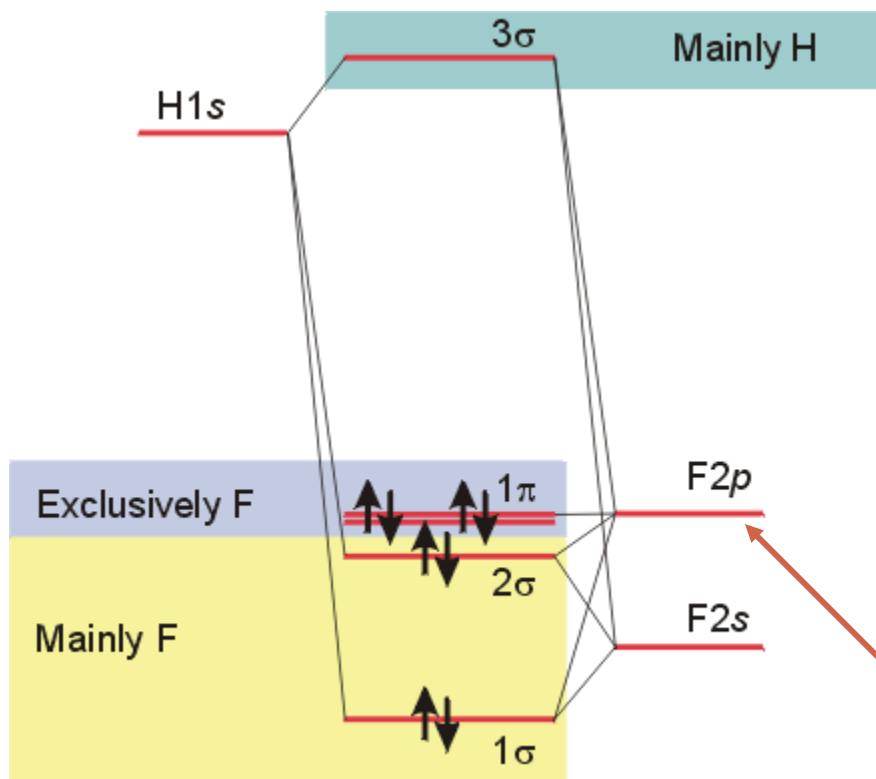

The $2s$ and $2p_x$ orbitals on fluorine interact with the $1s$ orbital on hydrogen.

The p_y and p_z orbitals on fluorine lack proper symmetry to interact with hydrogen, and remain as non-bonding orbitals.

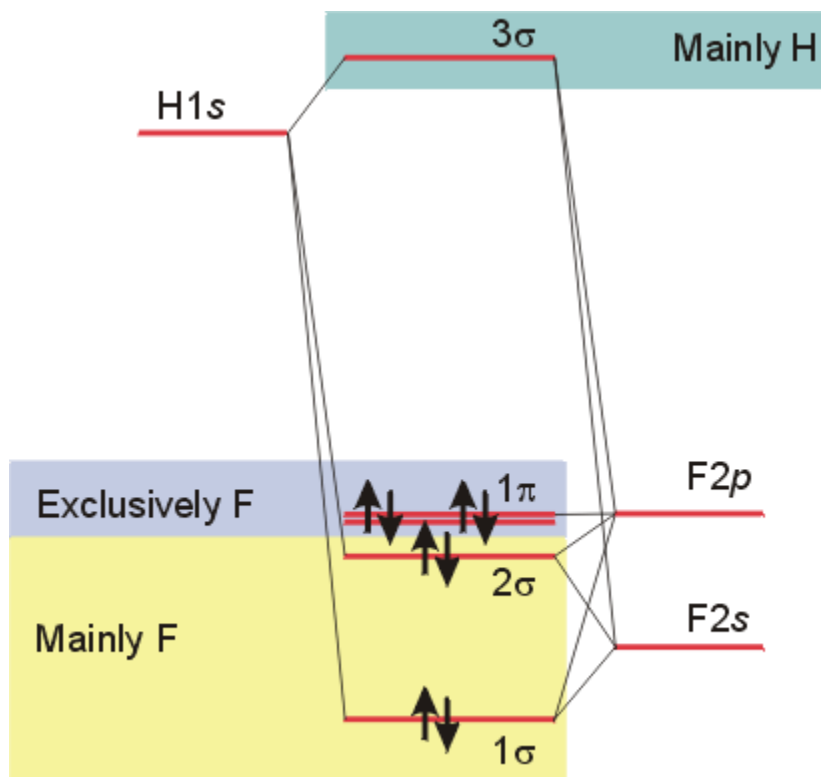

The anti-bonding orbital resides primarily on the less electronegative atom (H).

Note that the subscripts *g* and *u* are not used, as the molecule no longer has a center of symmetry.

Carbon monoxide

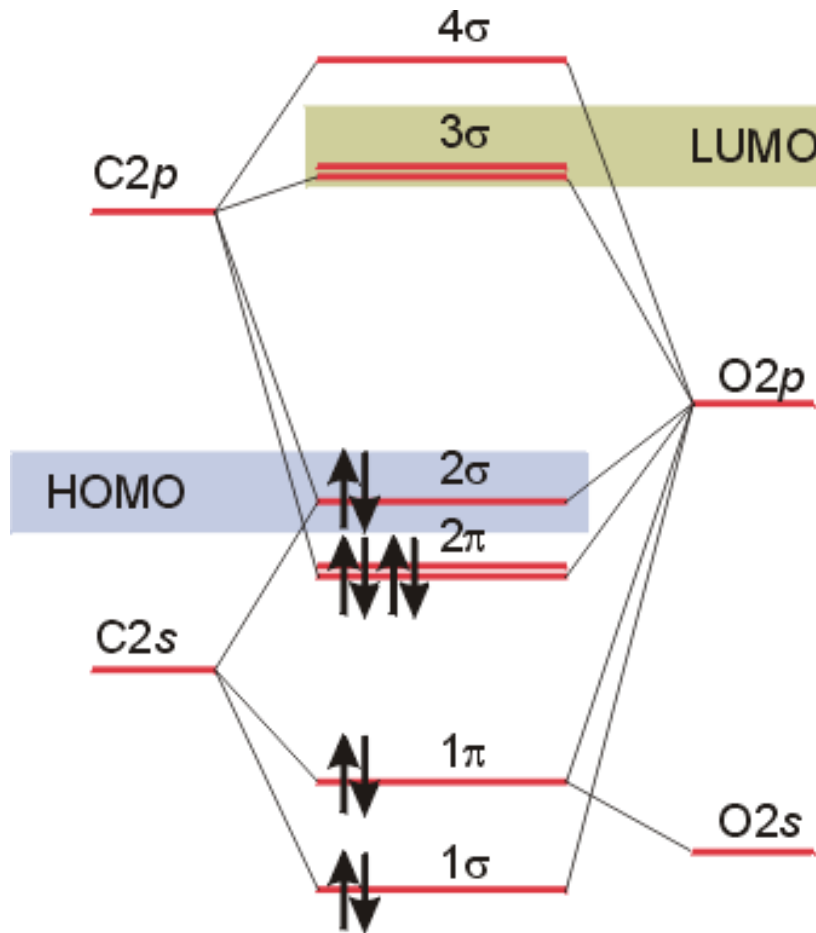

In carbon monoxide, the bonding orbitals reside more on the oxygen atom, and the anti-bonding orbitals reside more on the carbon atom.

Carbon monoxide

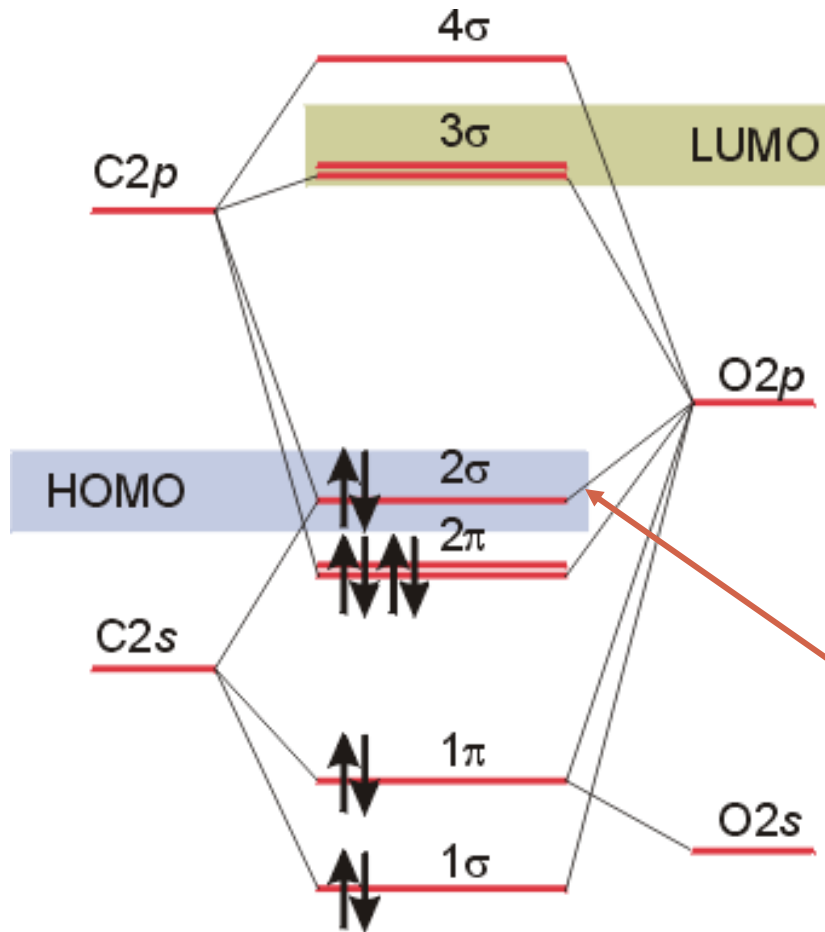

CO is a highly reactive molecule with transition metals. Reactivity typically arises from the highest occupied molecular orbital (HOMO), when donating electrons.

Carbon monoxide

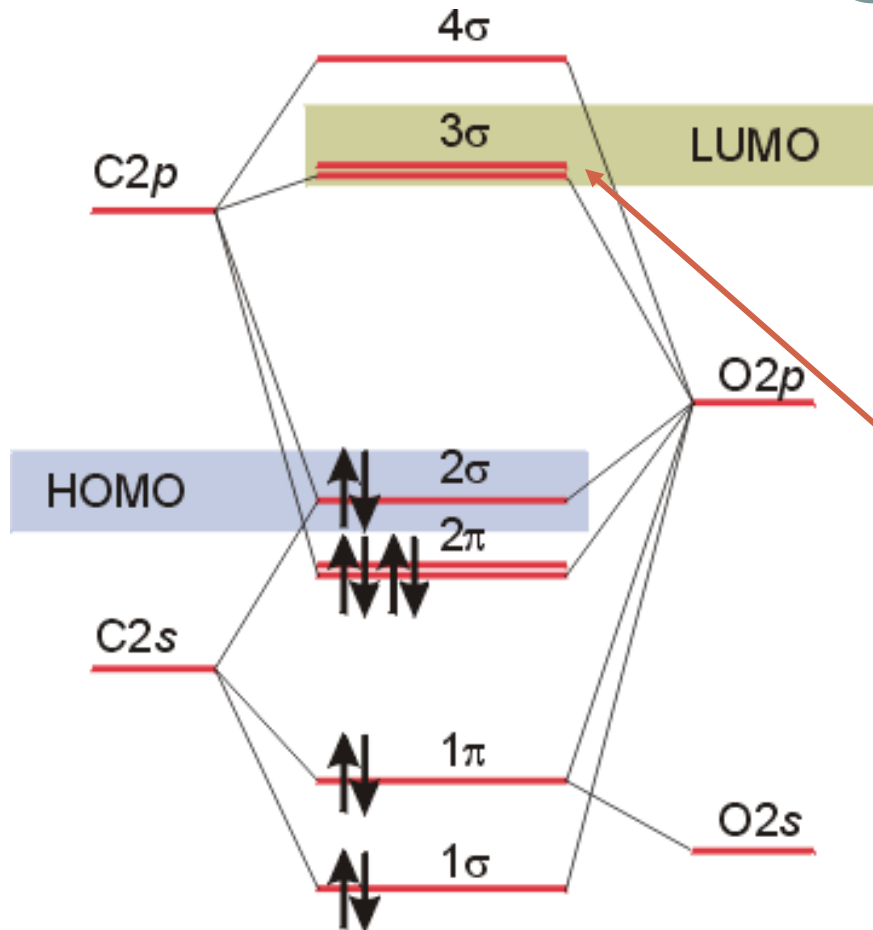

When acting as an electron pair acceptor, the lowest unoccupied molecular orbital (LUMO), is significant.

Carbon monoxide

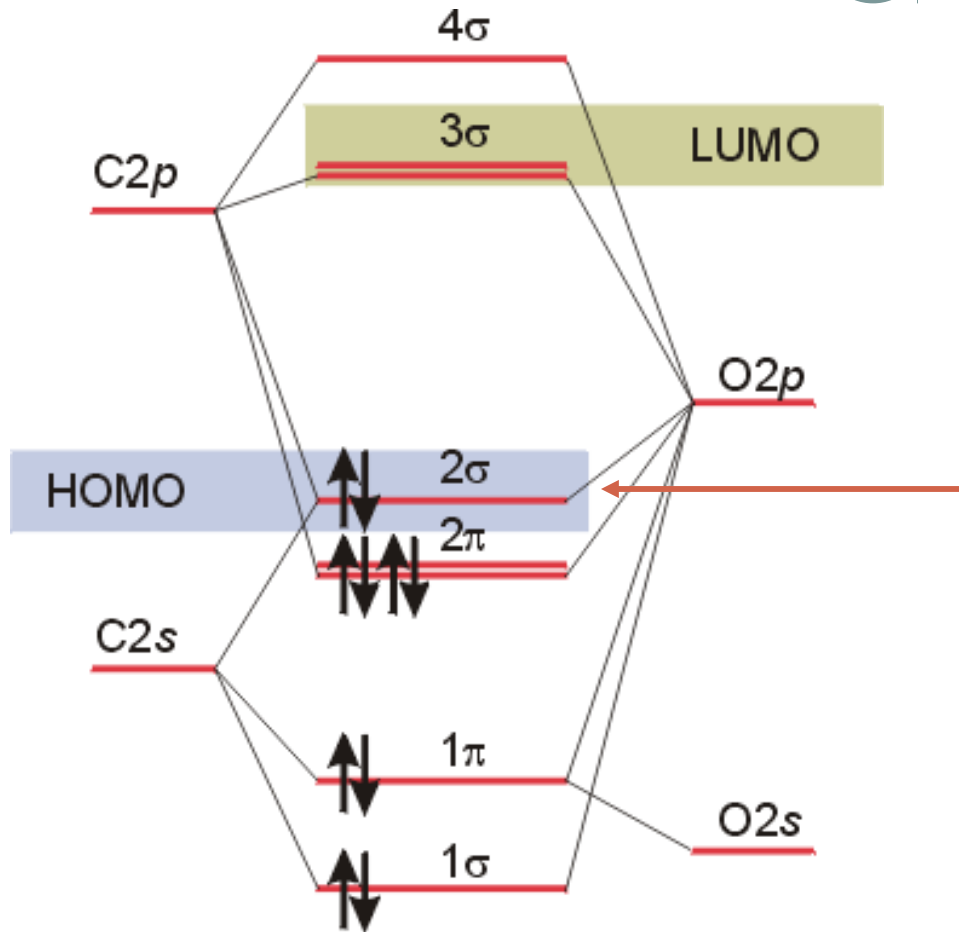

When acting as an electron pair donor, the highest occupied molecular orbital (HOMO), is significant.

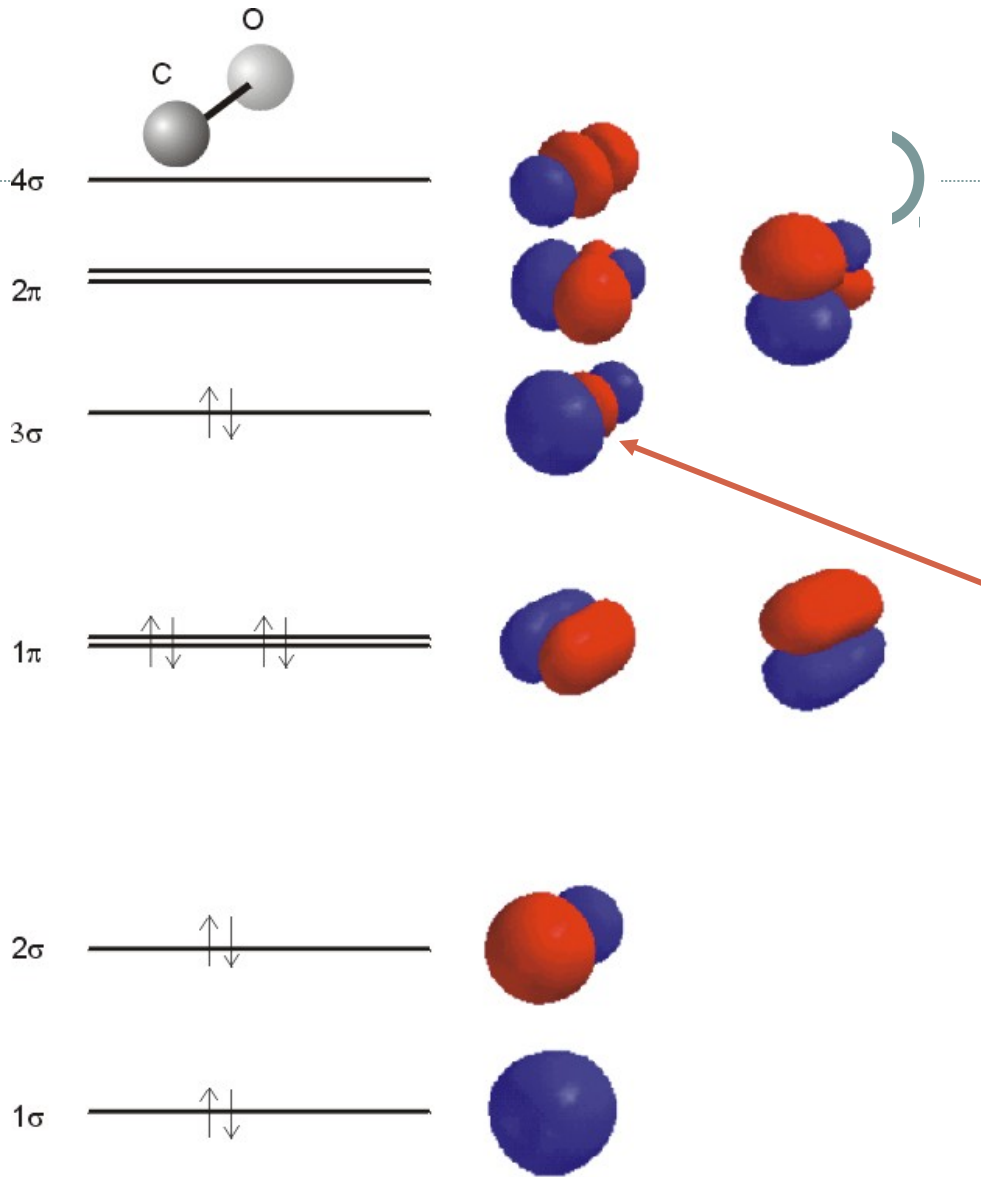

The highest occupied molecular orbital of CO is a molecular orbital which puts significant electron density on the carbon atom.

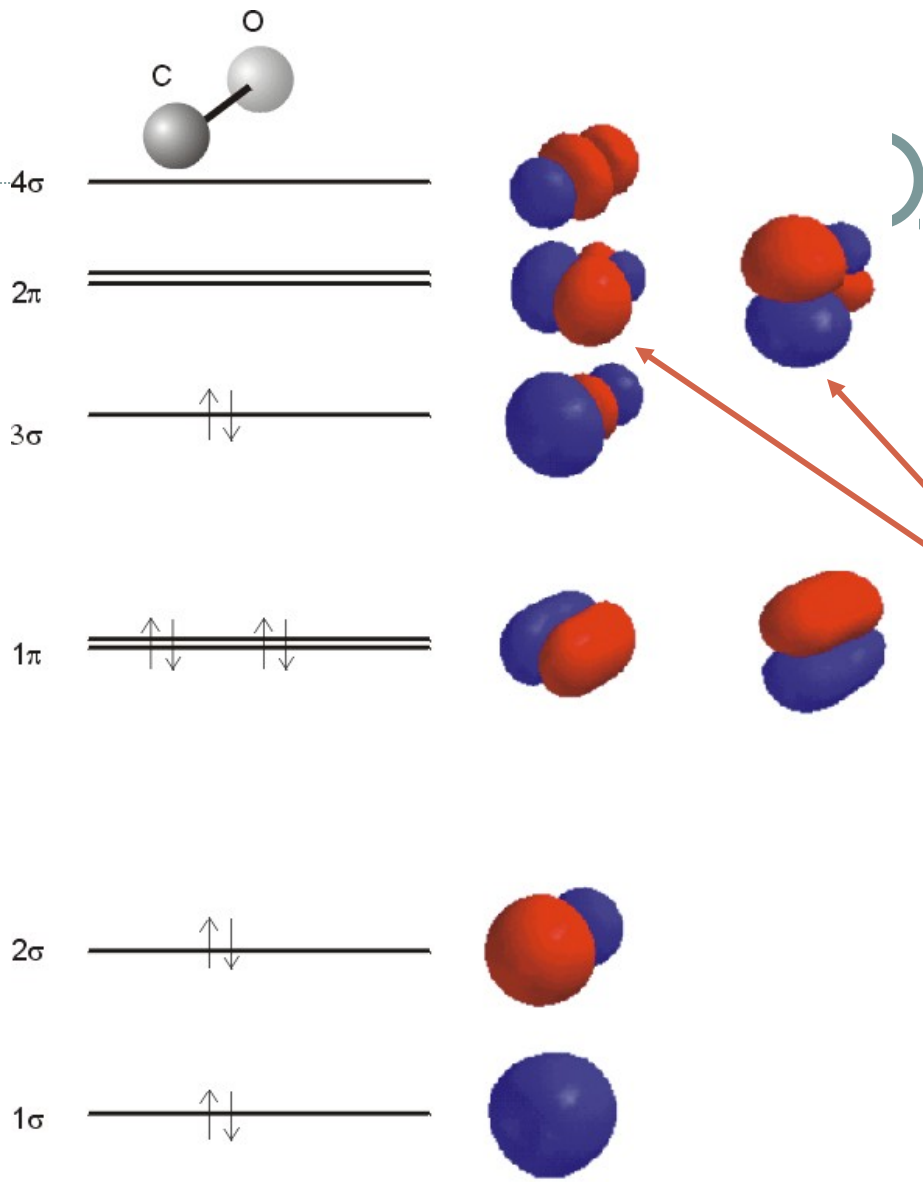

The lowest unoccupied molecular orbital of CO is the π^* orbitals. The lobes of the LUMO are larger on the carbon atom than on the oxygen atom.

CO as a Ligand

Carbon monoxide is known as a σ donor and a π acceptor ligand. It donates electrons from its HOMO to form a sigma bond with the metal.

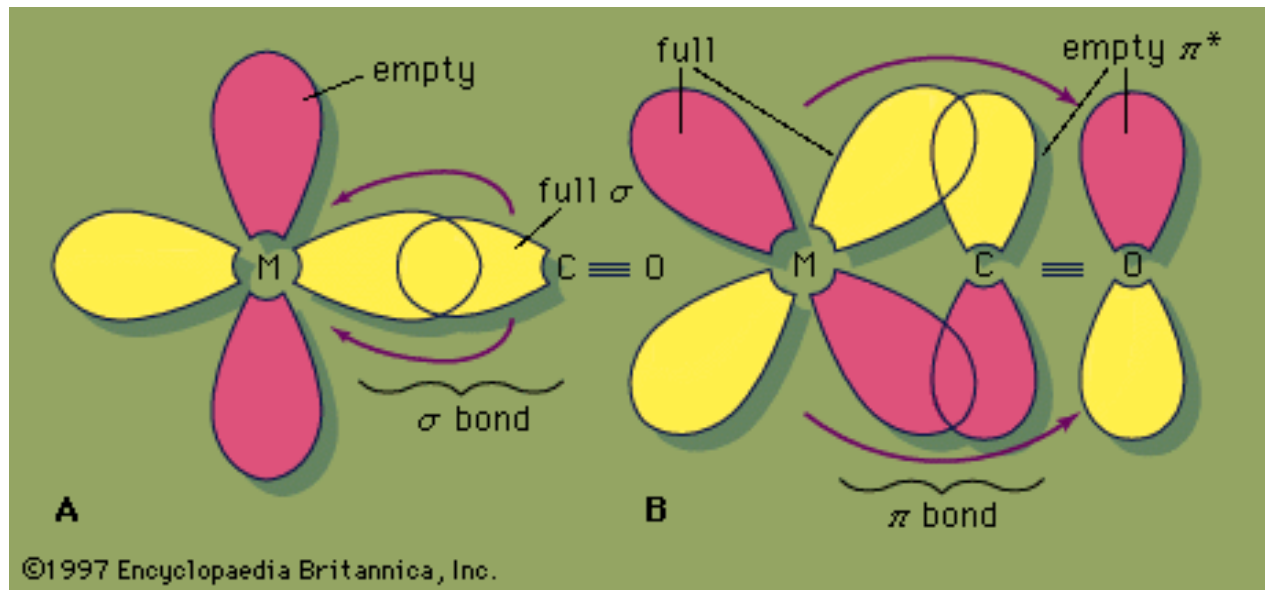

CO as a Ligand

Carbon monoxide accepts electrons from filled d orbitals on the metal into its antibonding (LUMO) orbital.

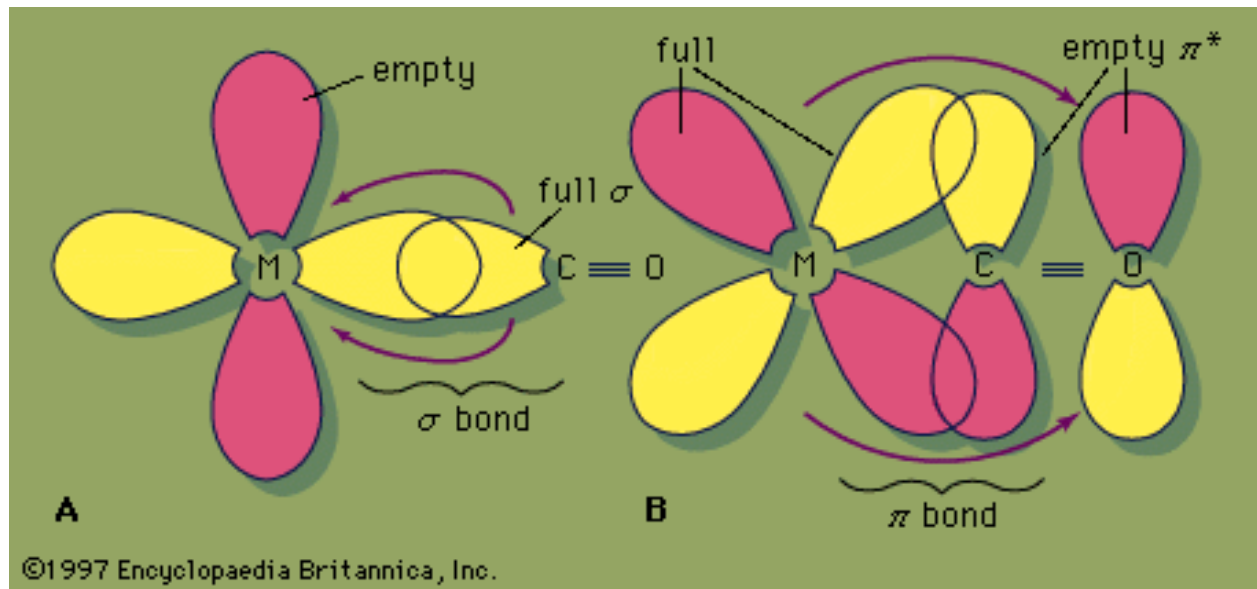

CO as a Ligand

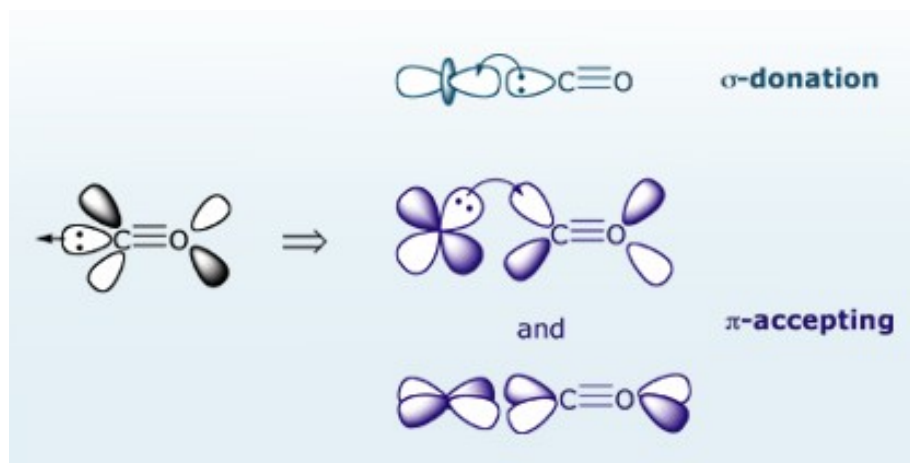

This phenomenon is called *back bonding*. The increased electron density in the antibonding orbitals of CO causes an increase in the C-O bond length and a decrease in its stretching frequency.

MOs for Larger Molecules



Group theory is usually used to develop molecular orbital diagrams and drawings of more complicated molecules. When a central atom is bonded to several atoms of the same element (H_2O , BF_3 , or PtCl_4^{2-}], group theory can be used to analyze the symmetry of the orbitals of the non-central atoms, and then combine them with the appropriate orbitals of the central atom.

MOs for Larger Molecules



The orbitals of the non-central atoms are called *group orbitals*. In considering a simple example, H_2O , we obtain group orbitals using the two $1s$ orbitals on the hydrogen atoms.

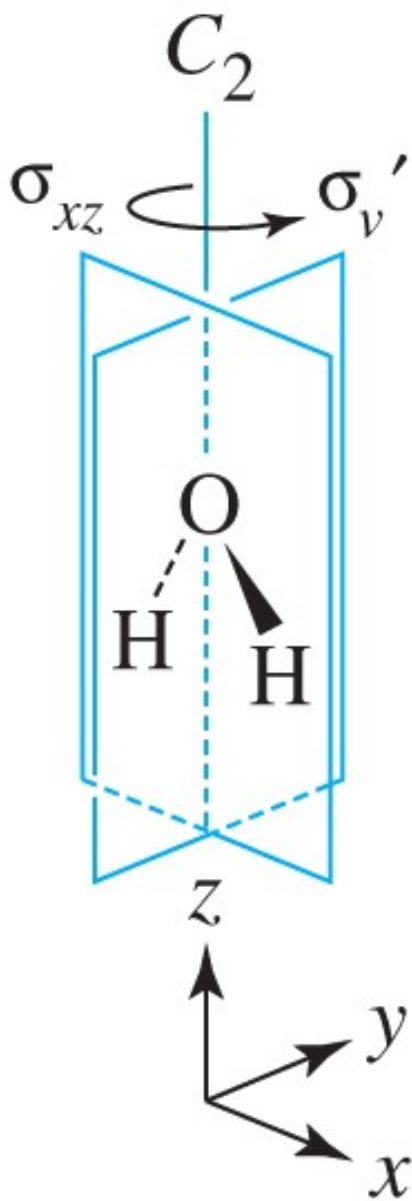

The characters for the group orbitals is obtained by considering each hydrogen as a spherical $1s$ orbital. They remain in position for identity, are exchanged during rotation, remain in place for σ_{xz} (the molecular plane), and are exchanged for σ_{yz} .

Group Orbitals of Water



Γ_{red} and its irreducible representations are:

The reducible representation $\Gamma = A_1 + B_1$:

C_{2v}	E	C_2	$\sigma_v(xz)$	$\sigma_v'(yz)$	
Γ	2	0	2	0	
A_1	1	1	1	1	z
B_1	1	-1	1	-1	x

Group Orbitals of Water



The A_1 representation has both $1s$ orbitals with positive wave functions: $H_a + H_b$.



The B_1 representations is $H_a + H_b$.



Group Orbitals of Water



These group orbitals are combined with orbitals on oxygen that have the same symmetry.

C_{2v} Character Table

C_{2v}	E	C_2	$\sigma_v(xz)$	$\sigma_v'(yz)$	
A_1	1	1	1	1	z
A_2	1	1	-1	-1	R_z
B_1	1	-1	1	-1	x, R_y
B_2	1	-1	-1	1	y, R_x

Group Orbitals of Water



C_{2v} Character Table

C_{2v}	E	C_2	$\sigma_v(xz)$	$\sigma_v'(yz)$	
A_1	1	1	1	1	z
A_2	1	1	-1	-1	R_z
B_1	1	-1	1	-1	x, R_y
B_2	1	-1	-1	1	y, R_x

The $2s$ and $2p_z$ orbital on oxygen have A_1 symmetry, the $2p_x$ orbital has B_1 symmetry, and the $2p_y$ has B_2 symmetry.

Molecular Orbitals of Water



Since the $2p_y$ orbital on oxygen doesn't match the symmetry of the group orbitals of hydrogen, it will remain non-bonding. The other orbitals on oxygen will combine with the appropriate group orbitals to form bonding and antibonding molecular orbitals.

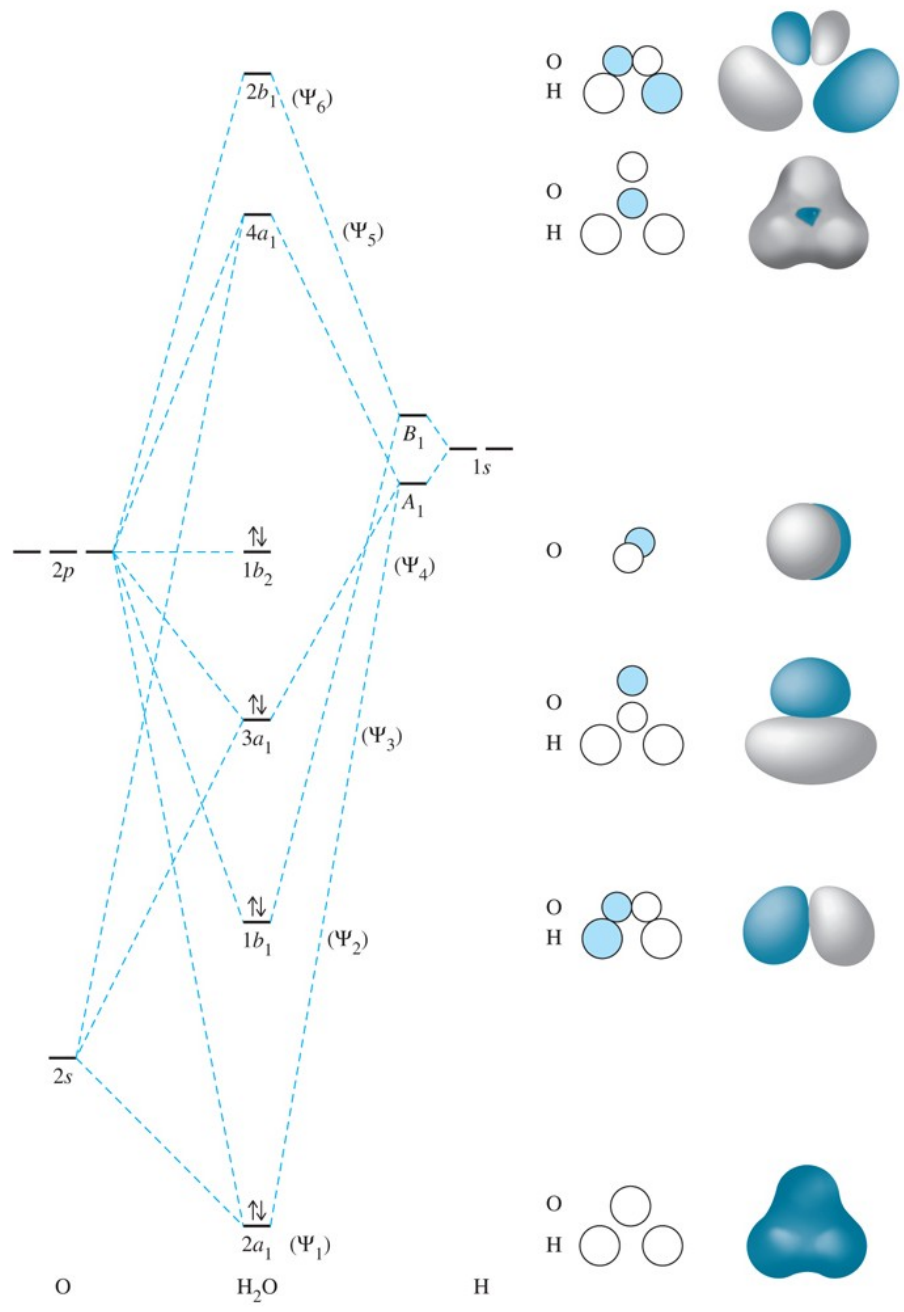

MOs for Larger Molecules



Group theory is usually used to develop molecular orbital diagrams and drawings of more complicated molecules. A simplified example will be shown for the π bonding of benzene.

π Bonding of Benzene



Benzene belongs to point group D_{6h} . In determining the orbital combinations for π bonding, we need to obtain Γ_{π} by looking only at the p_z orbitals on each carbon atom.

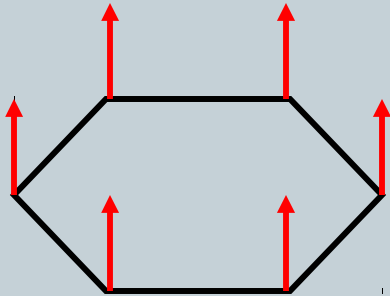

We need only consider those orbitals on carbon atoms that remain in place for a given symmetry operation.

π Bonding of Benzene

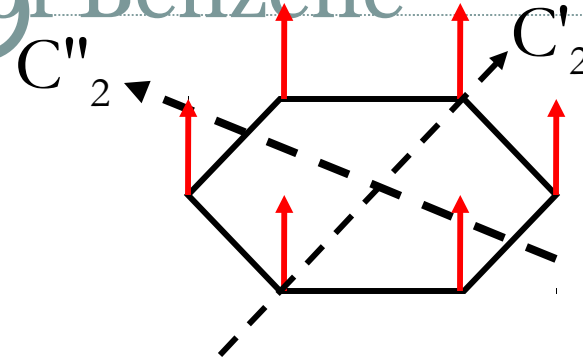

z axis

D_{6h} E $2C_6$ $2C_3$ C_2 $3C'_2$ $3C''_2$ i $2S_3$ $2S_6$ σ_h $3\sigma_d$ $3\sigma_v$

Γ_π

π Bonding of Benzene

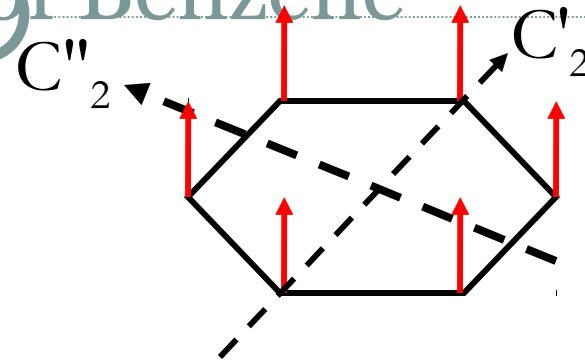

z axis

D_{6h}	E	$2C_6$	$2C_3$	C_2	$3C'_2$	$3C''_2$	i	$2S_3$	$2S_6$	σ_h	$3\sigma_d$	$3\sigma_v$
Γ_π	6	0	0	0	-2	0	0	0	0	-6	0	2

π Bonding of Benzene

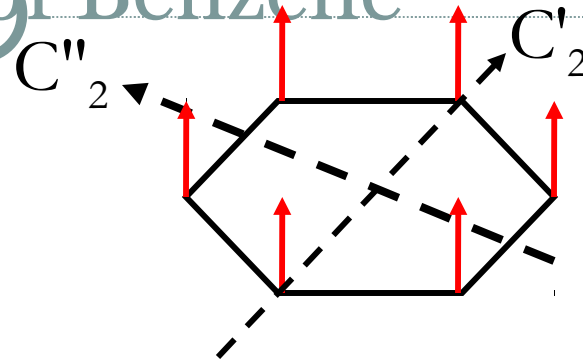

z axis

D_{6h}	E	$2C_6$	$2C_3$	C_2	$3C'_2$	$3C''_2$	i	$2S_3$	$2S_6$	σ_h	$3\sigma_d$	$3\sigma_v$
Γ_π	6	0	0	0	-2	0	0	0	0	-6	0	2

This reduces to: $B_{2g} + E_{1g} + A_{2u} + E_{2u}$

π Bonding of Benzene



$$\Gamma\pi: B_{2g} + E_{1g} + A_{2u} + E_{2u}$$

Group theory can be used to draw each of the π molecular orbitals. Molecular orbitals with fewer nodes are lower in energy (more bonding), and those with more nodes are higher in energy (more antibonding).

π Bonding of Benzene



$$\Gamma\pi: B_{2g} + E_{1g} + A_{2u} + E_{2u}$$

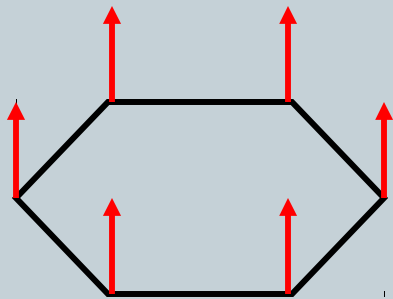

A_{2u} fully bonding and lowest in energy

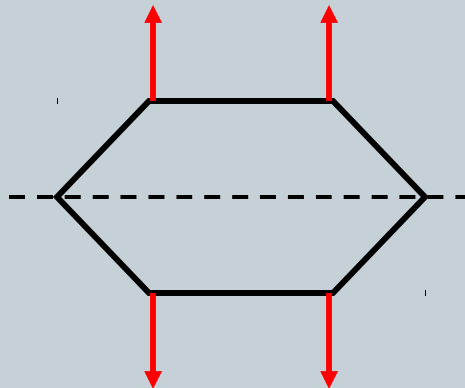
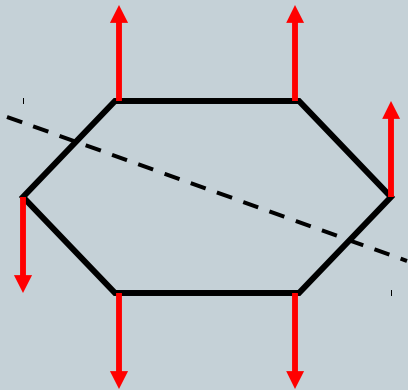

E_{1g} degenerate bonding orbitals with one node

π Bonding of Benzene



$$\Gamma\pi: B_{2g} + E_{1g} + A_{2u} + E_{2u}$$

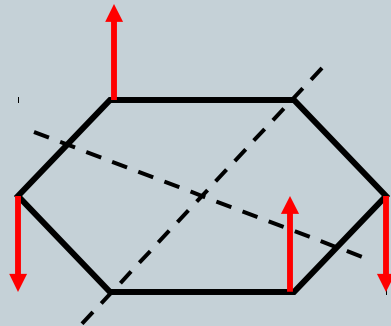
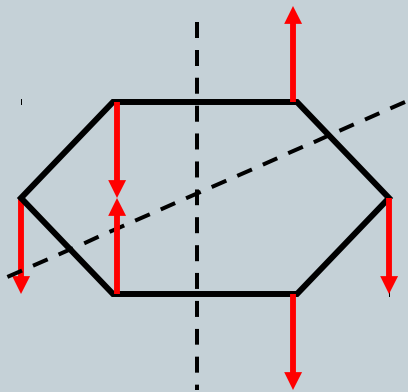

E_{2u} degenerate
largely anti-
bonding orbitals
with two nodes

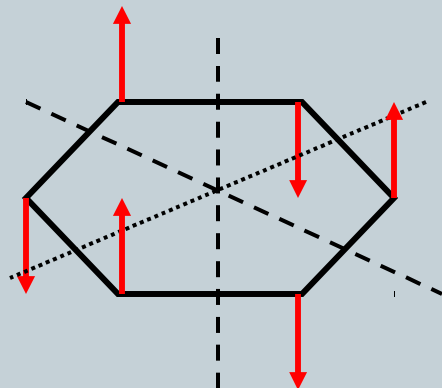

B_{2g} fully anti-
bonding orbital
with three nodes

π Bonding of Benzene

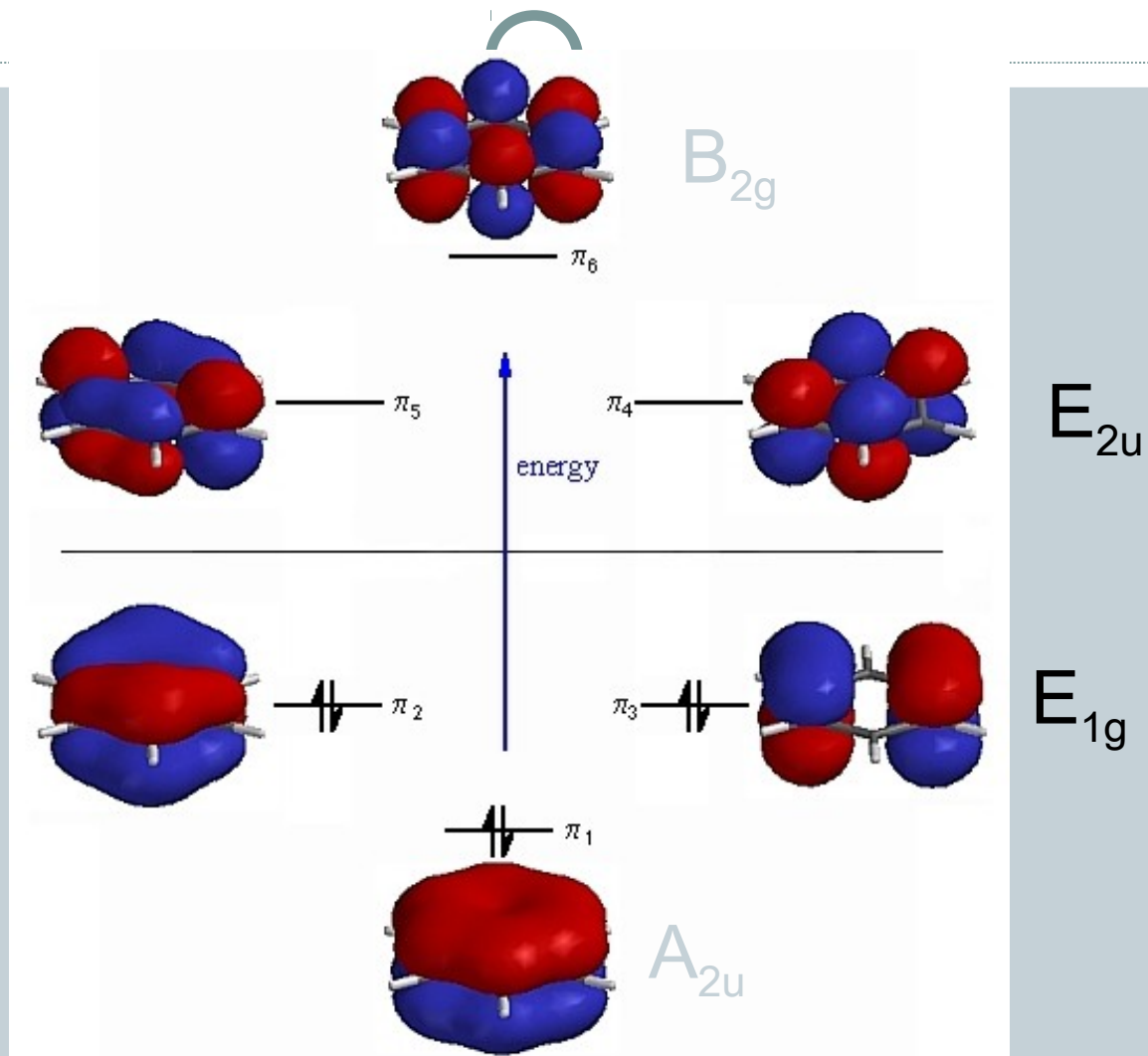

Molecular Orbitals of Complexes



Group theory is also used to construct molecular orbital diagrams for the complexes of metal atoms or ions. The symmetry combinations of the atomic orbitals on the ligands are determined, and then “matched” with appropriate atomic orbitals on the central metal. Both σ and π bonding between the metal and ligands can be considered.