

# Methods of Neutral Grounding

# Contents

- i. **Grounding or Earthing**
- ii. **System Grounding**
- iii. **Methods of Neutral Grounding**
- iv. **Solid Grounding**
- v. **Resistance Grounding**
- vi. **Reactance Grounding**
- vii. **Resonant Groundings/Peterson coil Groundings**

# Grounding or Earthing

*“The process of connecting the metallic frame of electrical equipment or some electrical part of the system (e.g. neutral point in a star-connected system) to earth (i.e. soil) is called grounding or earthing.”*

# System Grounding

*“The process of connecting some electrical part of the power system (e.g. neutral point of a star-connected system, one conductor of the secondary of a transformer etc.) to earth (i.e. soil) is called system grounding.”*

To understand the importance of system grounding, let's illustrate it pictorially .

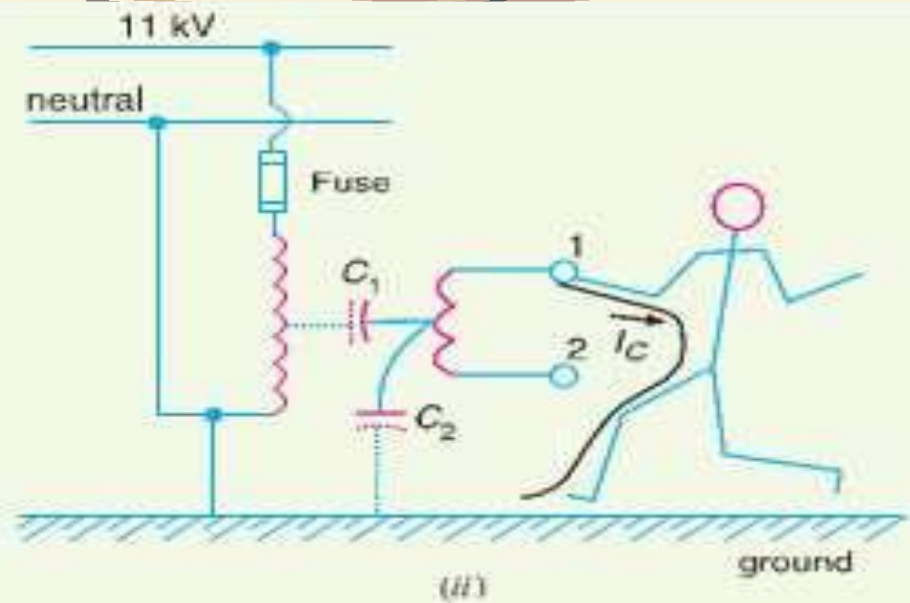
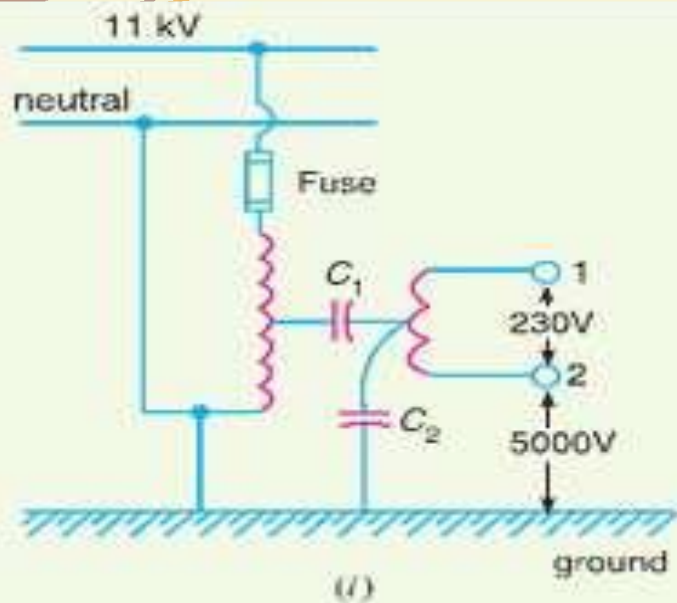
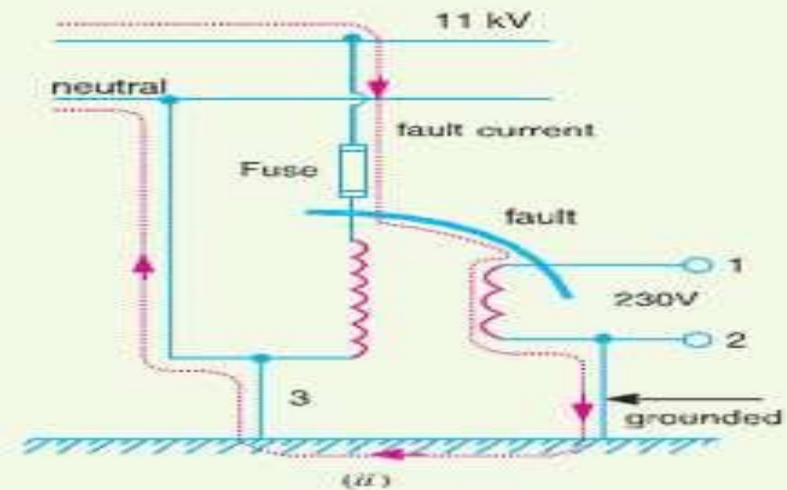
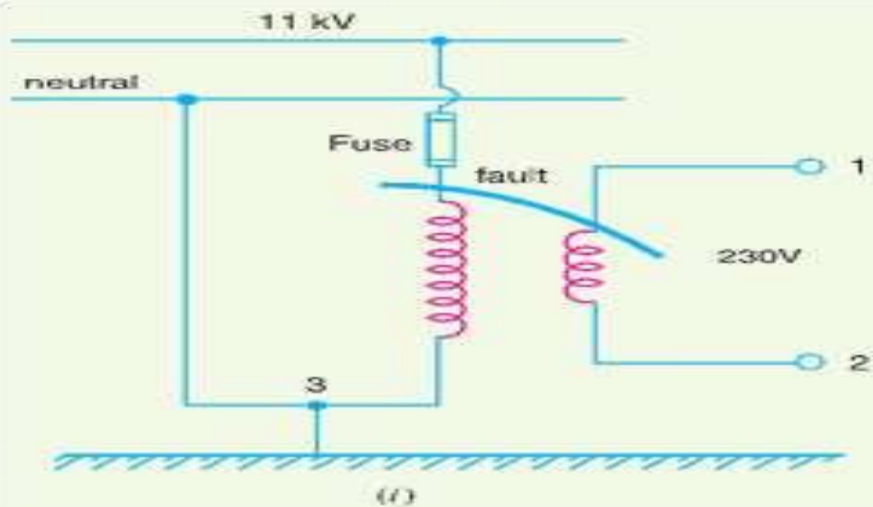
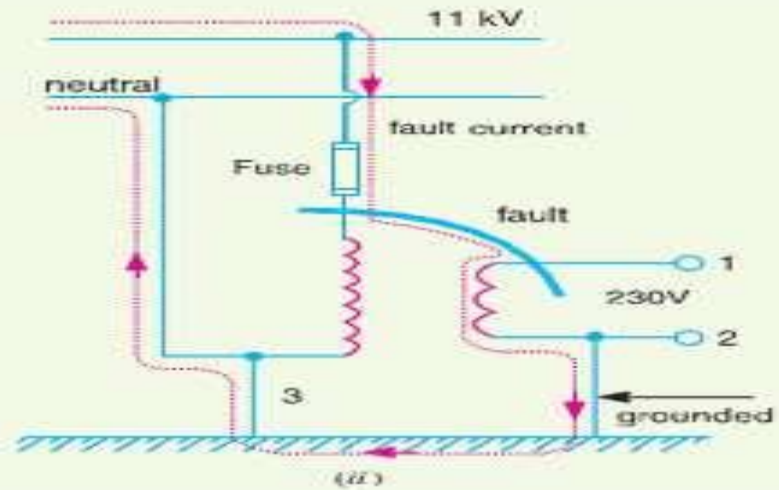
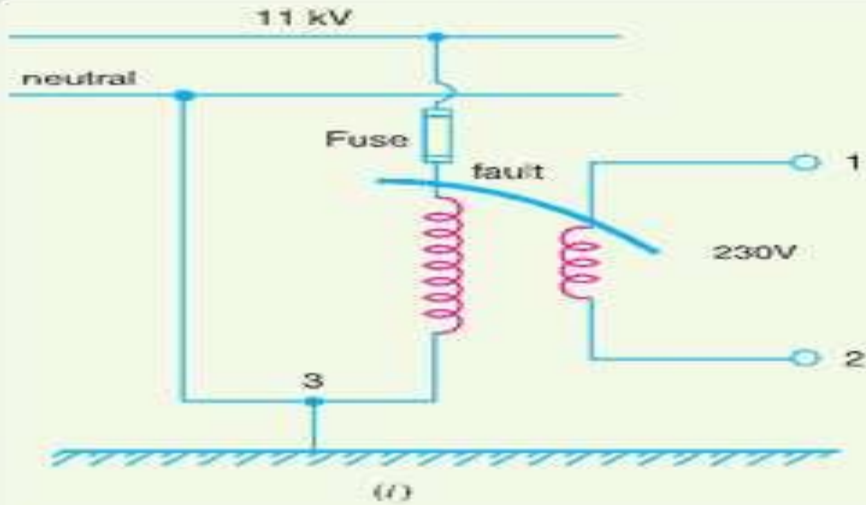

Fig. shows the primary winding of a distribution transformer connected between the line and neutral of a 11kV line. There is capacitance  $C_1$  between primary and secondary and capacitance  $C_2$  between secondary and ground. This capacitance coupling can produce a high voltage between the secondary lines and the ground.

If a person touches either one of the secondary wires, the resulting capacitive current  $I_C$  flowing through the body could be dangerous even in case of small transformers.



- Let us now turn to a more serious situation. Fig. shows the primary winding of a distribution transformer connected between the line and neutral of a 11kV line.
- The secondary conductors are ungrounded.
- Suppose that the high voltage line (11 kV in this case) touches the 230 V conductor as shown in previous slide.
- Under these circumstances, a very high voltage is imposed between the secondary conductors and ground.



- If one of the secondary lines is grounded as shown in Fig.(ii), the accidental contact between a 11kV conductor and a 230 V conductor produces a deadshort.
- The short-circuit current (i.e. fault current) follows the dotted path shown in Fig. 26.6 (ii).
- This large current will blow the fuse on the 11 kV side, thus disconnecting the transformer and secondary distribution system from the 11kV line.

# Methods of Neutral Grounding

The methods commonly used for grounding the neutral point of a 3-phase system are :

- Solid or effective grounding
- Resistance grounding
- Reactance grounding
- Peterson-coil grounding

The choice of the method of grounding depends upon many factors including the size of the system, system voltage and the scheme of protection to be used.



# Solid Grounding

*“When the neutral point of a 3-phase system (e.g. 3-phase generator, 3-phase transformer etc.) is directly connected to earth (i.e. soil) through a wire of negligible resistance and reactance, it is called solid grounding or effective grounding.”*

Fig. shows the solid grounding of the neutral point. Since the neutral point is directly connected to earth through a wire, the neutral point is held at earth potential under all conditions.

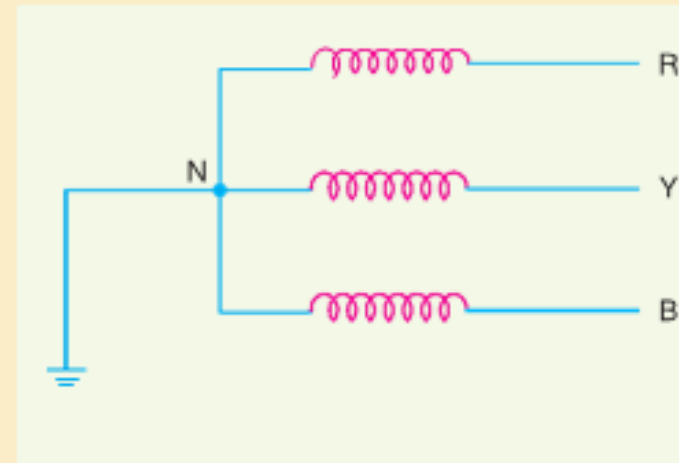

# Advantages

- The neutral is effectively held at earth potential.
- When there is an earth fault on any phase of the system, the phase to earth voltage of the faulty phase becomes zero. However, the phase to earth voltages of the remaining two healthy phases remain at normal phase voltage because the potential of the neutral is fixed at earth potential. This permits to insulate the equipment for phase voltage. Therefore, there is a saving in the cost of equipment.

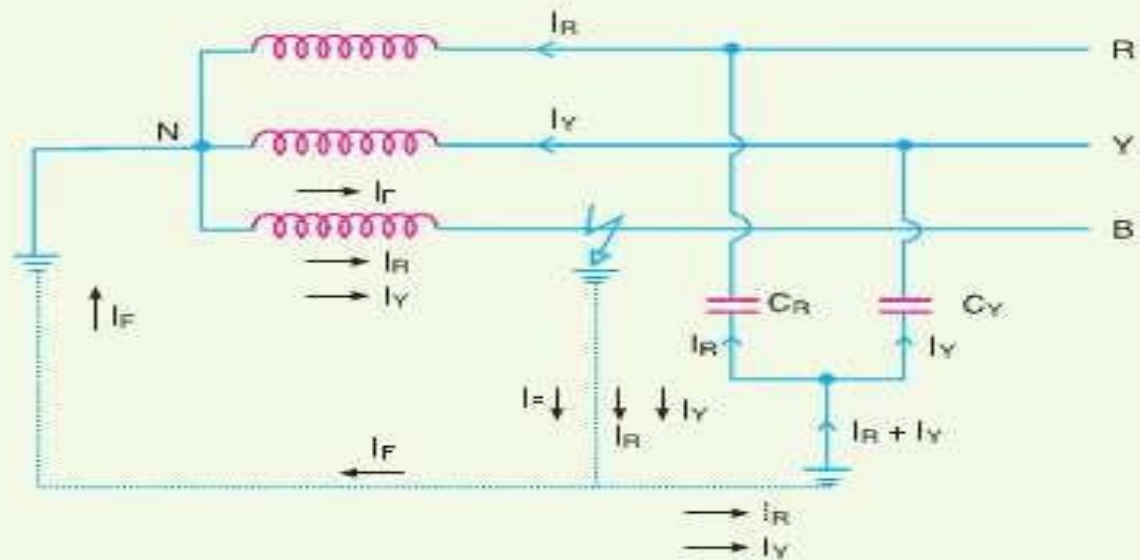

- When earth fault occurs on any phase, the resultant capacitive current  $I_C$  is in phase opposition to the fault current  $I_F$ . The two currents completely cancel each other. Therefore, no arcing ground or over-voltage conditions can occur.
- When there is an earth fault on any phase of the system, the phase to earth voltage of the faulty phase becomes zero. However, the phase to earth voltages of the remaining two healthy phases remain at normal phase voltage because the potential of the neutral is fixed at earth potential. This permits to insulate the equipment for phase voltage. Therefore, there is a saving in the cost of equipment.

# Disadvantages

The following are the disadvantages of solid grounding :

- i.
- ii. Since most of the faults on an overhead system are phase to earth faults, the system has to bear a large number of severe shocks. This causes the system to become unstable.
- iii. The solid grounding results in heavy earth fault currents. Since the fault has to be cleared by the circuit breakers, the heavy earth fault currents may cause the burning of circuit breaker contacts.
- iv. The increased earth fault current results in greater interference in the neighbouring communication lines.

# Applications of Solid Grounding At KAPCO

- Solid grounding is usually employed where the circuit impedance is sufficiently high so as to keep the earth fault current within safe limits. This system of grounding is used for voltages up to 33kV with total power capacity not exceeding 5000 kVA.
- At KAPCO all non current carrying mechanical parts e.g. generators outer covers, transmission lines poles, mechanical supports of CT's and PT's are Solid Grounded.
- Secondary star point 11 KV to 220 KV unit transformer is also solid grounded. This is due to the reason that at secondary side current is very low because of high voltage and even in case of un-balanced load the neutral current is very low.

# Resistance Grounding

In order to limit the magnitude of earth fault current, it is a common practice to connect the neutral point of a 3-phase system to earth through a resistor. This is called *resistance grounding*.

*When the neutral point of a 3-phase system (e.g. 3-phase generator, 3-phase transformer etc.) is connected to earth (i.e. soil) through a resistor, it is called **resistance grounding**.*

- Fig. shows the grounding of neutral point through a resistor  $R$ .
- The value of  $R$  should neither be very low nor very high.
- If the value of earthing resistance  $R$  is very low, the earth fault current will be large and the system becomes similar to the solid grounding system.
- On the other hand, if the earthing resistance  $R$  is very high, the system conditions become similar to ungrounded System

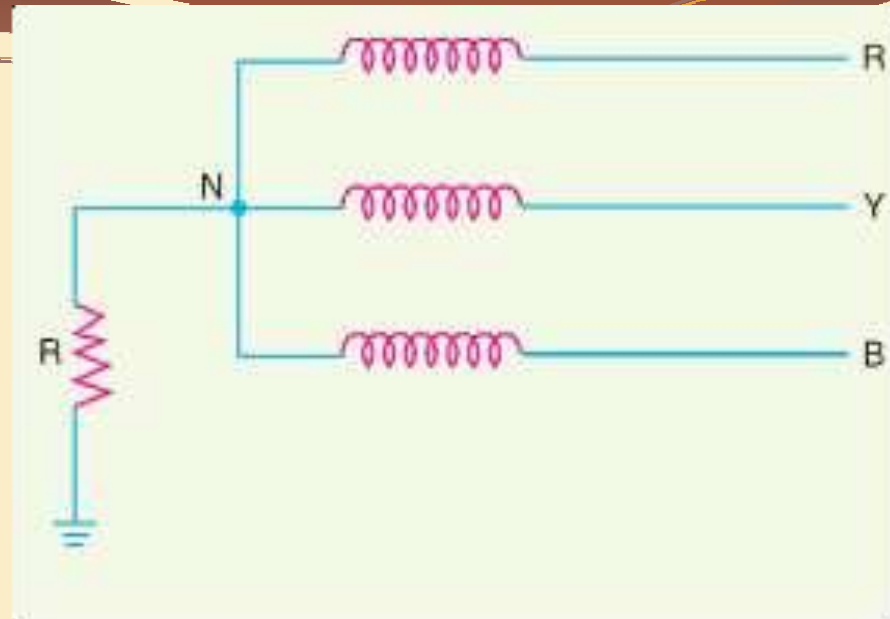

- The value of  $R$  is so chosen such that the earth fault current is limited to safe value but still sufficient to permit the operation of earth fault protection system.
- In practice, that value of  $R$  is selected that limits the earth fault current to 2 times the normal full load current of the earthed generator or transformer.



# Advantages of Resistance Grounding

The following are the advantages of resistance earthing:

- By adjusting the value of  $R$ , the arcing grounds can be minimized.
- The earth fault current is small due to the presence of earthing resistance. Therefore, interference with communication circuits is reduced.
- It improves the stability of the system.



- The fault current  $I_F$  can be resolved into two components *viz.*
  - i.  $I_{F1}$  in phase with the faulty phase voltage.
  - ii.  $I_{F2}$  lagging behind the faulty phase voltage by  $90^\circ$ .
  
- The lagging component  $I_{F2}$  is in phase opposition to the total capacitive current  $I_C$ .
- If the value of earthing resistance  $R$  is so adjusted that  $I_{F2} = I_C$ , the arcing ground is completely eliminated and the operation of the system becomes that of solidly grounded system. However, if  $R$  is so adjusted
  - that  $I_{F2} < I_C$ , the operation of the system becomes that of ungrounded neutral system.

# Disadvantages of Resistance Grounding

The following are the disadvantages of resistance grounding:

- Since the system neutral is displaced during earth faults, the equipment has to be insulated for higher voltages.
- This system is costlier than the solidly grounded system.
- A large amount of energy is produced in the earthing resistance during earth faults. Some-times it becomes difficult to dissipate this energy to atmosphere.

# Applications of Resistance Grounding At

- It is used on a system operating at voltages between 2.2 kV and 33kV with power source capacity more than 5000 kVA.
- At KAPCO the star point of 11KV 11KV Auxiliary Transformer (BBT) is solid grounded
- So, in case of unbalanced load the high neutral current of auxiliary transformer is limited by applying resistance 'R' between star point and ground(Soil)

# Reactance Grounding

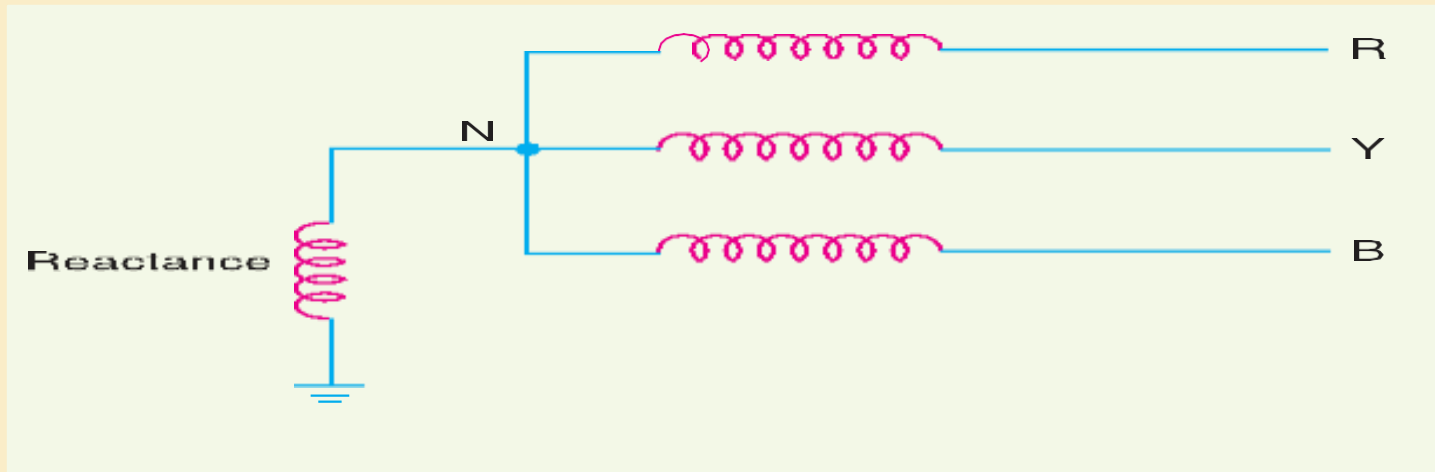

- In this system, a reactance is inserted between the neutral and ground as shown in Fig. The purpose of reactance is to limit the earth fault current. By changing the earthing reactance, the earth fault current can be changed to obtain the conditions similar to that of solid grounding.

# Disadvantages of Reactance Grounding

This method is not used these days because of the following disadvantages :

- In this system, the fault current required to operate the protective device is higher than that of resistance grounding for the same fault conditions.
- High transient voltages appear under fault conditions.

# Arc Suppression Coil Grounding (or Resonant Grounding)

We have seen that capacitive currents are responsible for producing arcing grounds. These capacitive currents flow because capacitance exists between each line and earth.

If inductance  $L$  of appropriate value is connected in parallel with the capacitance of the system, the fault current  $I_F$  flowing through  $L$  will be in phase opposition to the capacitive current  $I_C$  of the system. If  $L$  is so adjusted that  $I_L = I_C$ , then resultant current in the fault will be zero.

*“When the value of  $L$  of arc suppression coil is such that the fault current  $I_F$  exactly balances the capacitive current  $I_C$ , it is called resonant grounding.”*



# Circuit Details

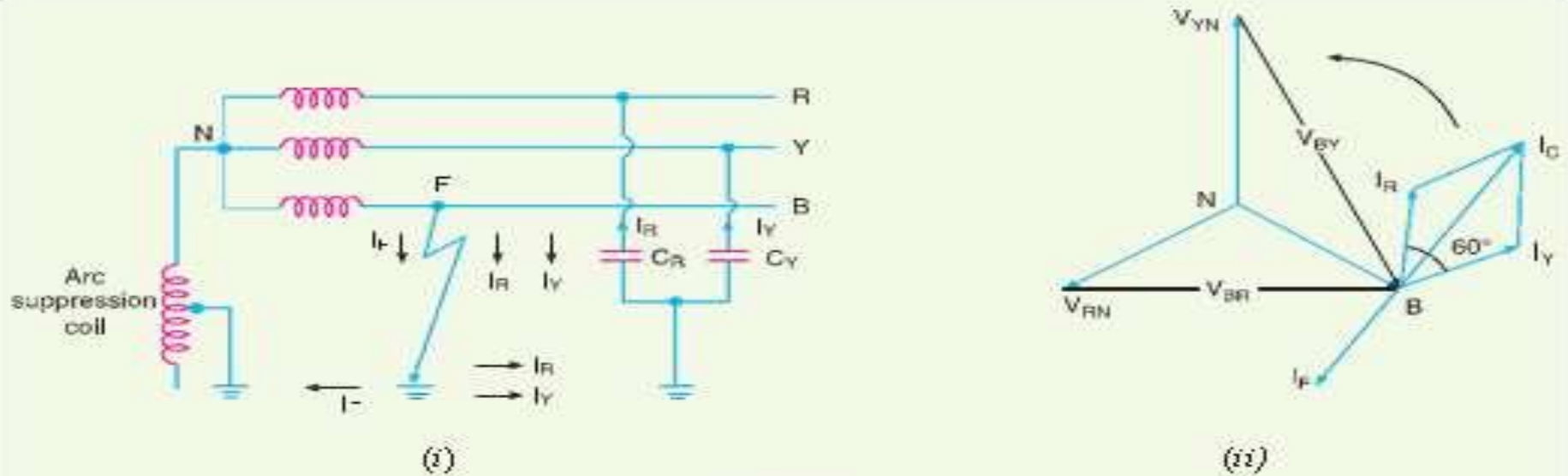

Fig. 26.16

- An arc suppression coil (also called Peterson coil) is an iron-cored coil connected between the neutral and earth as shown in Fig.
- The reactor is provided with tapplings to change the inductance of the coil. By adjusting the tapplings on the coil, resonant grounding can be achieved

# Advantages of Resonant Grounding

The Peterson coil grounding has the following advantages:

- The Peterson coil is completely effective in preventing any damage by an arcing ground.
- The Peterson coil has the advantages of ungrounded neutral system

# Disadvantages of Resonant Grounding

The Peterson coil grounding has the following disadvantages :

- Due to varying operational conditions, the capacitance of the network changes from time to time. Therefore, inductance  $L$  of Peterson coil requires readjustment.
- The lines should be transposed.

# Applications of Resonant Grounding

- At KAPCO the circuitry of resonant grounding is achieved by using the windings of a transformer as resonant coil
- The particular value of inductance 'L' is obtained by using known number of turns in transformer windings.
- The Neutral point (star point) of power generator is resonant grounded because of above discussed advantages.