

**AN INTRODUCTION TO**  
**POWER SYSTEM FAULT ANALYSIS**

## **INTRODUCTION**

**A fault calculation is the analysis of the power system electrical behaviour under fault conditions, with particular reference to the effects on the system currents and voltages. Accurate fault calculations are essential for proper system design. The analysis of fault conditions and their effects on the power system is of particular relevance to such conditions as:**

- a. the choice of a suitable power system arrangement, with particular reference to the configuration of the transmission or distribution network.**
- b. the determination of the required load and short-circuit ratings of the power system plant.**
- c. the determination of the breaking capacity required of the power system switchgear and fusegear.**
- d. the design and application of equipment for the control and protection of the power system.**
- e. the operation of the system, with particular reference to security of supply and economic considerations.**
- f. the investigation of unsatisfactory performance of the power system or of individual items of power system plant.**

## **Types of Fault**

**In the context of electrical fault calculations, a power system fault may be defined as any condition or abnormality of the system which involves the electrical failure of primary equipment, i.e. generators, transformers, busbars, overhead lines and cables and all other items of plant which operate at power system voltage.**

**Electrical failure generally implies one of two conditions or types of failure (sometimes both), namely insulation failure resulting in a short-circuit condition or a conducting path failure resulting in an open-circuit condition, the former being by far the more common type of failure.**

a) **Short-circuited phases**

**Faults of this type are caused by insulation failure between phase conductors or between phase conductors and earth, or both. Figure 1 gives details of the various short-circuited-phase faults.**

**Figure 1: Short-circuited-phase faults**

**The three-phase fault, which may or may not be to earth, is the only balanced short-circuit condition and is the one used as the standard in determining the system fault levels or ratings.**

**b) Open-circuited phases**

**Faults of this type, see Figure 2, result in the failure of one or more phases to conduct.**

**The more common causes of this type of fault are joint failures on overhead lines and cables, and the failure of circuit-breakers or isolators to close properly. Both the single-phase and the two-phase conditions are of particular interest because they tend to produce unbalance of the power system currents and voltages with the consequent risk of damage to rotating plant.**

**Figure 2: Open-circuited phase faults**

**c) Simultaneous faults**

**A simultaneous fault condition, or a multiple fault condition, is defined as the simultaneous presence of two or more faults which may be of similar or dissimilar types and may be at the same or different points in the power system.**

**The most common simultaneous fault condition is undoubtedly the double-circuit overhead line fault in which a common cause, i.e. lightning or clashing conductors, results in a fault on each of the two circuits concerned.**

**Another simultaneous fault condition is known as the cross-country earth-fault, in which a single-phase to earth fault at one point occurs coincidentally with a second such fault on another phase at some other point in the system.**

d) **Winding faults**

This type of fault, which can occur in machine or transformer windings, is detailed in Figure 3, and consists mainly of short circuits, from one phase to earth, or from phase to phase, or from one point to another on the same phase winding. The last fault condition is known as the short-circuited turns fault. This condition can pose special problems from a protection point of view because the current in the shorted turns can be very large, while that in the remainder of the winding may be quite small.

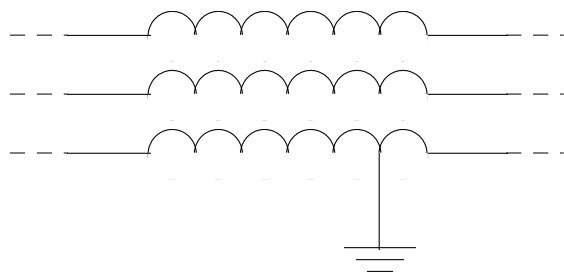

Phase-to-earth fault

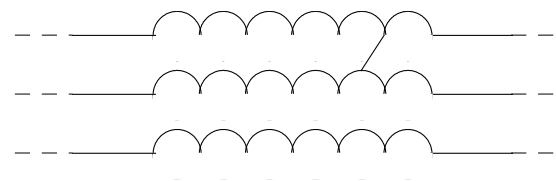

Phase-to-phase fault

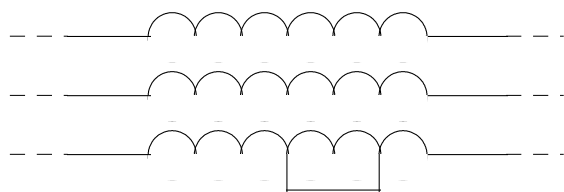

Short-circuited turns

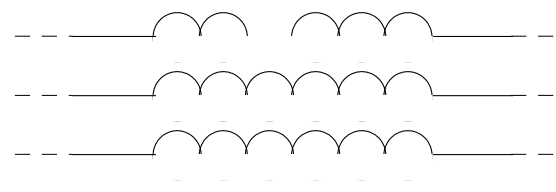

Open-circuited winding

**Figure 3. Winding faults**

The open-circuited winding condition is quite rare in practice and is usually the result of damage to the winding as a consequence of a preceding winding short circuit at or near the point of fault. Open circuits in transformers may also occur as a result of failure of tap-changing equipment.

## **Factors Affecting Fault Severity**

**The severity of a power system fault condition may be assessed in terms of the disturbance produced and the fault damage caused, the magnitude of the fault current and its duration being of particular interest, especially in relation to the design and application of the power system protection. The main factors which affect the severity of a fault are:**

### **a) Source conditions**

**These relate to the amount and location of all connected generation equipment - including the ties or interconnections with other systems, the two extremes of minimum and maximum connected plant being of particular interest. The minimum and maximum plant conditions are normally those corresponding to the conditions of minimum and maximum connected load.**



**b) Power system configuration**

**This is determined by the items of plant, i.e. generators, transformers, overhead lines and cable circuits, etc., assumed to be in service for the particular condition being investigated and by other such factors as may have a bearing on the make-up of the equivalent circuit of the system. The system configuration may change during the course of a fault with consequent changes in the magnitude and distribution of the fault currents. Typical causes of the above changes being the sequential tripping of the circuit-breakers at the two ends of the faulted transmission line and the sequential clearance of multiple fault conditions.**

**c) Neutral earthing**

**Faults which involve the flow of earth current, i.e. phase faults to earth, may be influenced considerably by the system neutral earthing arrangements, particularly by the number of neutral earthing points and the presence or absence of neutral earthing impedance. The power system may be single-point or multiple-point earthed and such earthing may be direct, i.e. solid earthing, or via a neutral impedance. The 132kV, 275kV and the 400kV systems employ direct multiple earthing while the 66kV and below generally employ single-point, sometimes multiple, resistance earthing.**

**d) Nature and type of fault**

**From what has been said already, it is evident that the type and location of a fault will have a significant effect on the magnitude and distribution of the system fault currents. Likewise, the effect of a given fault condition may be considerably modified by the simultaneous presence of one or more other fault conditions, for example, the combination of a short circuit and an open-circuited phase condition.**

**The wide range of possible system fault conditions and the many factors which influence them result in a wide range of possible fault severity, ranging from very low levels up to the maximum level possible for the system. It is of value to consider a standard fault condition when discussing systems and the three-phase fault level may be expressed in amperes but it is usually expressed in MVA, corresponding to the rated system voltage and the current for a symmetrical three-phase fault. This three-phase fault level normally determines the required short-circuit rating of the power system switchgear. A factor which may also have to be taken into account is the maximum value of the one-phase to earth fault current which, in a solidly earthed system, may exceed the maximum three-phase fault current.**

## **Methods of Fault Calculation**

- ◆ **The information normally required from a fault calculation is that which gives the values of the currents and voltages at stated points in the power system when a given fault condition is imposed on the system.**
- ◆ **A fault calculation is therefore, essentially a matter of network analysis and can be achieved by a number of methods, i.e. mesh-current or nodal-voltage methods, network reduction techniques or simulation using a network analyser.**
- ◆ **The choice of method depends on the size and complexity of the circuit model and the availability of computing facilities.**

## Methods of Fault Calculation

- ◆ **An essential part of power system analysis and fault calculation is that which concerns the determination of the equivalent system network for the system operating conditions and the fault conditions under consideration.**
- ◆ **As stated earlier, faults can be subdivided into either balanced (symmetrical) or unbalanced (unsymmetrical) fault conditions, this latter case being analysed, traditionally, by the method of symmetrical components.**
- ◆ **Both classes of fault are analysed by reducing the power system, with its fault condition, to an equivalent single-phase network.**

## **Balanced Faults**

**The balanced fault is often the severest and is the simplest to determine. Hence, this is the one normally used to determine the 'duty' of the system switchgear and busbars**

## **Fault Calculation Procedure**

**The analysis of a 3-phase balanced fault condition consists, in general, of three parts:**

- a. the system with its fault condition is represented by its positive sequence network,**
- b. the network is solved in terms of per-unit quantities,**
- c. the resulting per-unit quantities are converted to actual values.**

## **Component Representation**

**Overhead lines and cables are normally represented by their series impedance on the basis that the shunt impedance is high. Transformers and synchronous machines are normally represented by their reactances as the resistance values are relatively small. Load impedances are normally much larger than the other network impedances and hence, they are normally neglected in fault calculations.**

### **THREE PHASE FAULTS**

**The following example is presented to illustrate the methods employed for the case which induces positive sequence components only. The system shown represents a power station connected to the grid, together with its auxiliary systems. The principle circuit and plant parameters are given in Table 1.**



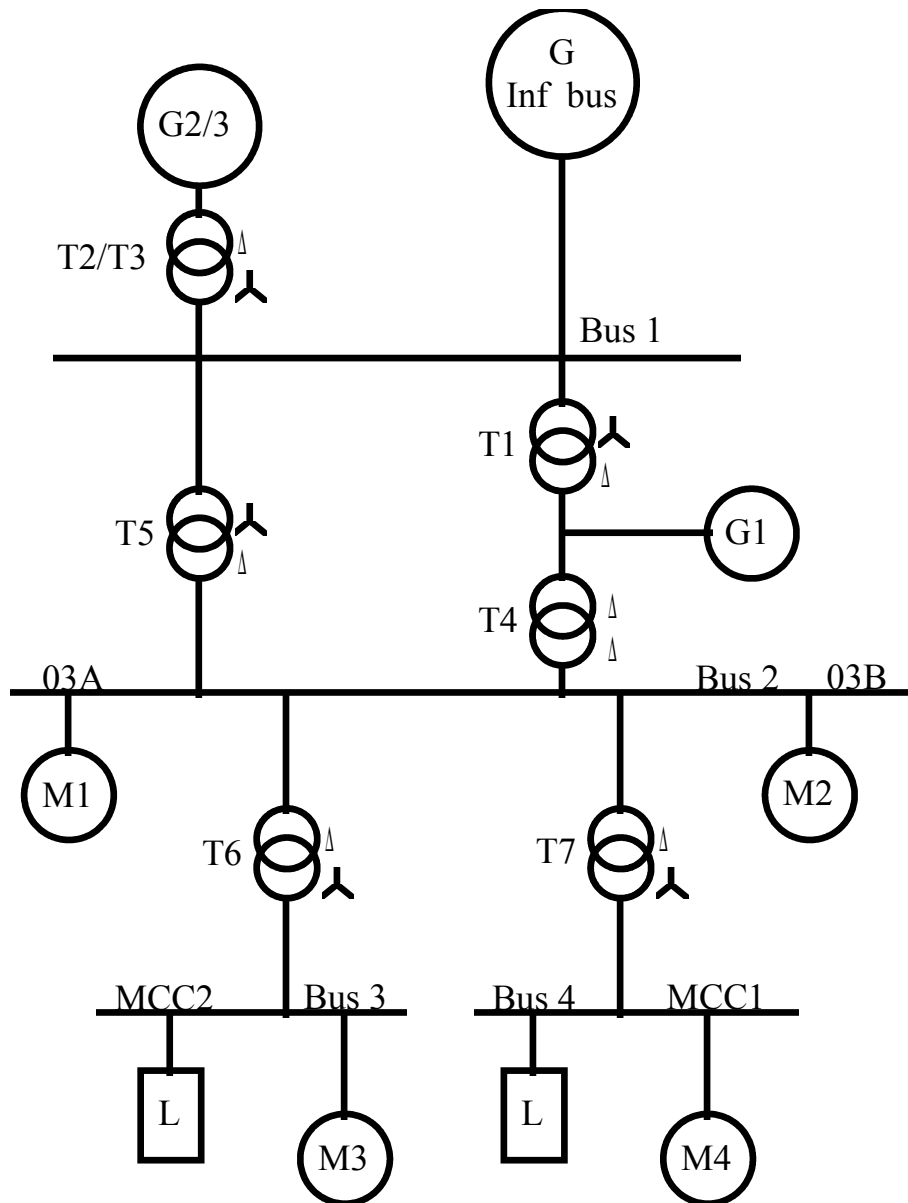

### Example

**A fault is assumed to occur first on busbar MCC1 and secondly on busbar MCC2. The fault level quoted on Bus 1 is 2500 MVA.**

G2/3	71 MVA, $X = 263$ pu on 100 MVA
T2/T3	71 MVA, $X_1 = 009$ pu
G	(2500-147-71)MVA
G1	147 MVA, $X_d = 1867$ pu
T1	150 MVA, $X_1 = 013$ pu
T4	16 MVA, $X_1 = 01$ pu
T5	16 MVA, $X_1 = 009$ pu
T6	2 MVA, $X_1 = 006$ pu
T7	4 MVA, $X_1 = 006$ pu
M1	88 MVA
M2	806 MVA
M3	1247 MVA
M4	0977 MVA
SL	0918 MW, 09 p.f.

**Table 1**

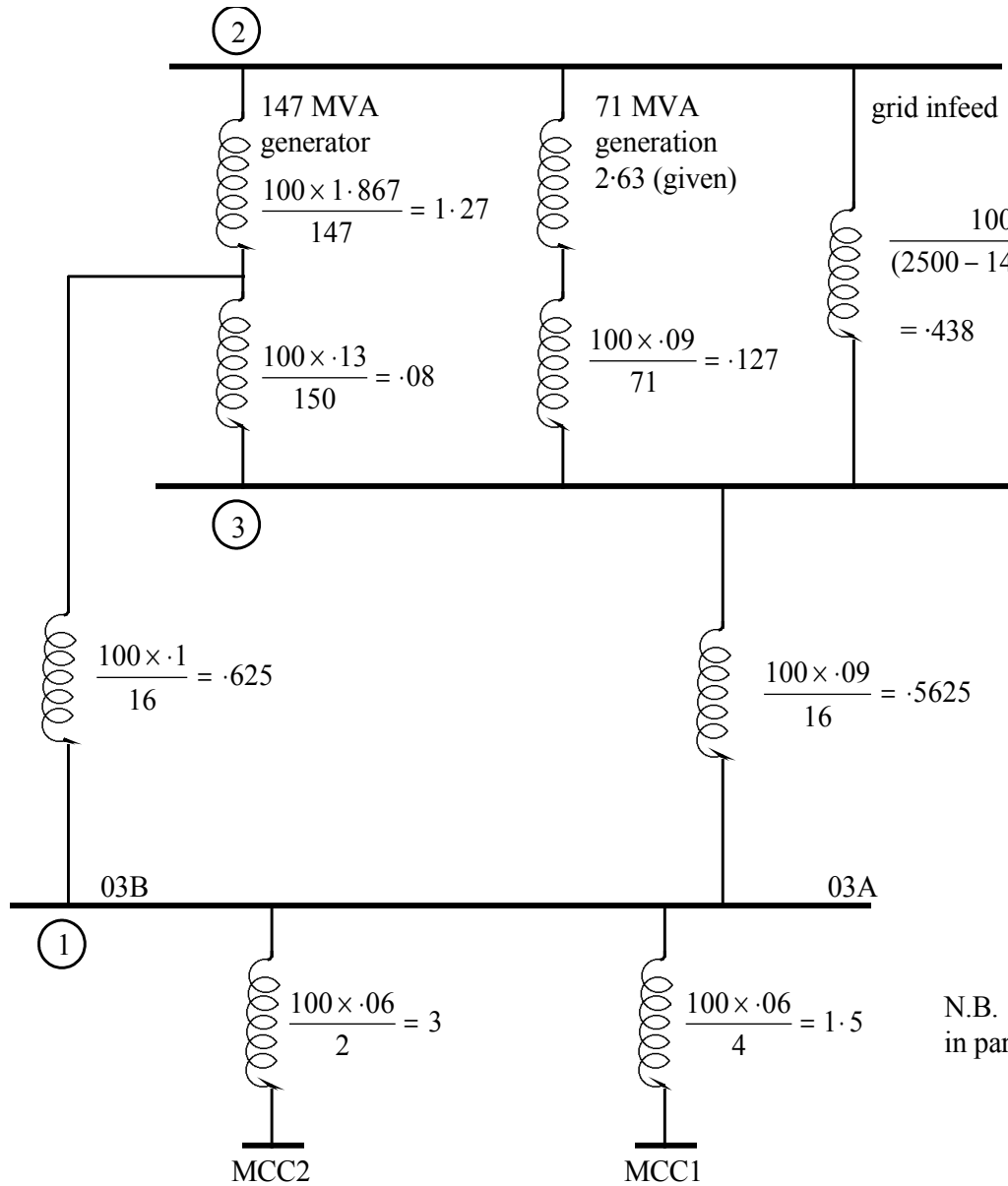

## Normalised system reactances on equivalent circuit

N.B. 2x2 MVA Transformers in parallel

Using the Star Delta Transform to simplify the above circuit

SC MVA<sub>(D33/D3A)</sub> =

$I_f =$

kA

SC MVA<sub>(VCD2)</sub> =

$I_f = 43071 \text{ A}$

SC MVA<sub>(VCD1)</sub> =

$I_f = 77970 \text{ A}$

## **UNBALANCED FAULTS**

### **Symmetrical Components**

The fundamentals of the method of symmetrical components are in reality relatively simple to apply. However, the method is characterised by a large number of simple stage calculations which, once the fundamentals of the method are clearly understood, become quite easy to apply to practical system assessment.

**The resolution of the problem into sequence components results in considerable simplification of all problems involving asymmetry such as that introduced by short-circuiting conductors of a system either together or to earth, singly or in pairs, or by the open circuiting of a conductor. The resolution of the problem into sequence components has the further advantage in that it isolates the quantities into components which represent a better criteria of the controlling factor or factors in certain phenomena.**

**Consider the following system of vectors shown below.**

A graphic vectorial representation is not tractable when dealing with complex practical systems. Consider the vector equations in which  $\vec{V}$ ,  $\vec{I}$  are written in terms of the positive, negative and zero sequence components  $V_0, V_1, V_2, I_0, I_1, I_2$ .

(1)



Rewriting equation (1), and for convenience neglecting the bar denoting vector quantities

$$\begin{aligned} V_a &= V_{a1} + V_{a2} + V_{a0} \\ V_b &= \lambda^2 V_{a1} + \lambda V_{a2} + V_{a0} \\ V_c &= \lambda V_{a1} + \lambda^2 V_{a2} + V_{a0} \end{aligned} \quad (2)$$

and  $V_{a0}$ ,  $V_{a1}$  and  $V_{a2}$  may now be written as  $V_0$ ,  $V_1$  and  $V_2$

where  $\lambda$  is an operator which moves a vector  $120^\circ$  anticlockwise, i.e.

$$\begin{aligned} \lambda &= 0.5 + 0.886j \\ \lambda^2 &= -0.5 - 0.886j \\ \lambda^3 &= 1 \end{aligned} \quad (3)$$

Other useful identities are given in the following Table 1.

	$\lambda + \lambda^2 = -1$	$1 + \lambda^2 = 0.5 - 0.886j$
Table 1	$1 - \lambda + \lambda^2 = 0$	$1 - \lambda = 1.5 - 0.866j$
	$1 - \lambda = 0.5 + 0.866j$	$1 - \lambda^2 = 1.5 - 0.866j$

The transformation of phase quantities to sequence and reverse is given by

$$[\mathbf{V}_{\text{ph}}] = [\mathbf{T}] [\mathbf{V}_{\text{seq}}]$$

and

$$[\mathbf{V}_{\text{seq}}] = [\mathbf{T}]^{-1} [\mathbf{V}_{\text{ph}}]$$

where

$$[\mathbf{T}] = \begin{bmatrix} 1 & 1 & 1 \\ 1 & \lambda^2 & \lambda \\ 1 & \lambda & \lambda^2 \end{bmatrix} \quad (4)$$

and

$$[\mathbf{T}]^{-1} = \frac{1}{3} \begin{bmatrix} 1 & 1 & 1 \\ 1 & \lambda & \lambda^2 \\ 1 & \lambda^2 & \lambda \end{bmatrix} \quad (5)$$

Precisely the same form of equations apply if we replace voltages by currents

(6)

where  $[Z]$  is the impedance matrix of the network

For example, consider the network shown in the figure below

It follows that

$$[\mathbf{T}] \begin{bmatrix} V_0 \\ V_1 \\ V_2 \end{bmatrix} = [\mathbf{Z}] [\mathbf{T}] \begin{bmatrix} I_0 \\ I_1 \\ I_2 \end{bmatrix}$$

premultiplying equation (7) by  $[T]^{-1}$  the following sequence component equations are obtained.

$$\begin{bmatrix} V_0 \\ V_1 \\ V_2 \end{bmatrix} = [T]^{-1}[Z][T] \begin{bmatrix} I_0 \\ I_1 \\ I_2 \end{bmatrix}$$

For a balanced network

$$Z_{11} = Z_{22} = Z_{33} = Z_p$$

$$Z_{12} = Z_{23} = Z_{13} = Z_m$$

∴

represents a symmetrical transmission system impedance matrix.

Evaluating the term  $[T]^{-1} [Z] [T]$  defines the sequence impedances

$$[T]^{-1} [Z] [T] \quad (9)$$

**N.B.** The transformation diagonalises the impedance matrix, in which  $Z_1 = Z_2$ , i.e. positive and negative sequence impedances are equal. The sequence currents are obtained from:

(10)

Now consider the case where the circuit impedances are of the form

possible distribution for an electrical machine

(11)

resulting in sequence impedances of different values.



### Example

An untransposed transmission line gives rise to 3 per cent negative sequence voltage. Show approximately how this affects the magnitudes of the terminal voltages of the generator supplying the system.

No zero sequences voltage; let  $V_2 = 0.03 V_1$

$$V_a = V_1 + 0.03V_1 = (1 + 0.03)V_1$$

$$V_b = \lambda^2 V_1 + \lambda 0.03V_1 = (\lambda^2 + 0.03\lambda)V_1$$

$$V_c = \lambda V_1 + \lambda^2 0.03V_1 = (\lambda + 0.03\lambda^2)V_1$$

## **SINGLE-PHASE-EARTH FAULT**

Consider the simple representation of the single-phase-earth fault as shown  
The system is considered to be unloaded prior to the application of the fault.

Restating the primary equations for symmetrical component evaluation

The initial conditions for the fault are

$$I_B = I_C = 0$$

$$I_A = I_f$$

$$V_A = 0 \text{ (short-earth)}$$

Components of voltage

$$V_0 = E_0 - I_0 Z_0$$

$$V_1 = E_1 - I_1 Z_1$$

$$V_2 = E_2 - I_2 Z_2$$

---

$$V_A = E_A - (I_0 Z_0 + I_1 Z_1 + I_2 Z_2)$$

$V_A = 0$  and since the generator is only able to generate positive sequence components,

$$E_0 = E_2 = 0$$

Also, since  $I_B = I_C = 0$ ,  $I_0 = I_2 = 0$

$$I_1 = \frac{E_1}{Z_1 + Z_2 + Z_0}$$

The fault current  $I_f = I_A = 3I_1$

$$I_f = \frac{3E}{Z_1 + Z_2 + Z_0}$$

where E is the generated phase voltage.

The equivalent circuit is given by

## Example

$$\begin{aligned}X_1 &= 0.2j \text{ pu} \\X_2 &= 0.1j \text{ pu} \\X_0 &= 0.05j \text{ pu}\end{aligned}$$

Consider an earth fault at B

Choose base of 75 MVA,  $V_B = 33 \text{ kV}$

Consider generator reactances on new base

Line:

The next stage is to draw a sequence diagram. For the single phase to earth fault, the positive, negative and zero sequence diagrams are connected in series.



$$= \underline{-j3.49 \text{ kA}}$$

The fault current may be reduced by increasing the impedance to the fault. Using the data of the above example, consider the effect of earthing only one generator.

compared with  $0.887 I_1 = 0.84$  previously.

This clearly has not reduced the current significantly.

Consider placing an impedance in the earth path as shown

**N.B.** Zero sequence components only flow in the earth path.

$\therefore$  Zero sequence network becomes

To note the effect of an earthing resistor, consider the previous example modified to take account of a 3 ohm resistance connected between the star point of the generator and earth.

The sequence diagram becomes

$$I_0 = I_1 = I_2$$

$$I_1 = (0.621 - 1.19j)$$

$$I_f = 3 \times (0.621 - 1.19j) \times$$

$$= 2.93(0.621 - 1.19j) \text{ kA}$$

Too large a fault current can cause problems, nevertheless the fault current must be sufficient to be detected by protection.

However, before proceeding further, the effect of the transformer windings on the flow of zero sequence currents must be assessed.

Shown below are three connection diagrams for power transformers

Star / Star, primary and secondary windings earthed

$I_0$  will flow in primary and secondary circuits

Star / Star, primary winding earthed, secondary unearthed  
 $I_0$  cannot flow in secondary circuit

Star / Delta, primary winding earthed

$I_0$  flows in primary and circulates in the secondary

Shown below are the three equivalent circuits corresponding to the previous connection diagrams for the power transformers.

(a)

(b)

(c)



Shown below is the equivalent circuit for a three-winding transformer

Returning to the example and considering only the zero sequence diagram

The zero sequence impedance has been increased by  $Z_{0(\text{trans})}$  and therefore,  $I_f$  will be less.

Consider the  $\Delta/\Delta$  transformer replaced by a  $\Delta/\Delta$  .

Zero sequence diagram:

The  $RN$  is now out of circuit for an end of line fault. However, its effect is seen for a fault at the generator terminals.  $I_f$  will now rise as compared to previous case.

NONE OF CONFIGURATIONS AFFECT THE POSITIVE AND NEGATIVE SEQUENCE NETWORKS

A further modification involves the inclusion of second transformer

The Zero sequence diagram becomes

## **PRACTICAL FAULT STUDIES**

**As previously stated, power systems are subject to excessive damage when high magnitude currents are flowing due to system short circuit. The analysis so far has been confined to steady-state conditions arising subsequent to fault incidence. The initial transient condition has been neglected which, for many practical situations, is considered to be satisfactory. However, the instant of initiation of the short circuit relative to the voltage waveform, has a marked effect upon the maximum peak value of the short-circuit current which may be important from the point of view of fast acting fault clearance devices, i.e. does the circuit breaker operate prior to the decay of the transient component of the current.**

Consider the single phase equivalent circuit of a generator shown

If  $S$  is suddenly closed, the equation representing the equivalent circuit on a single phase basis is

The solution of which yields

where  $Z^2 = r^2 + \omega^2 L^2$  and  $\tan \phi =$

and

**The total current is obtained by adding the steady-state and the transient components.**

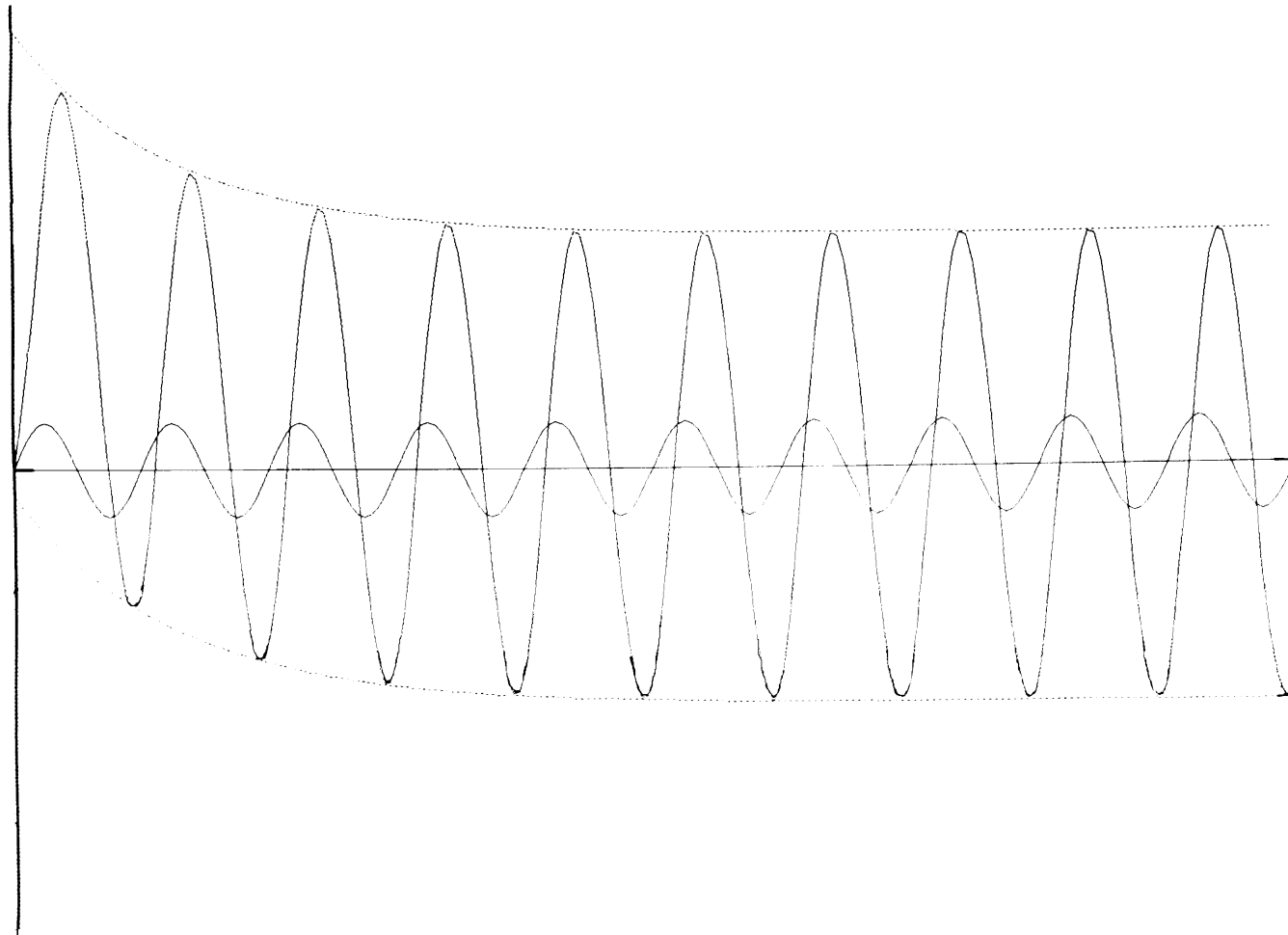

**In practice, the time variation of the short circuit current is dependent on the actual characteristic of the generator. To a close approximation, the short circuit current can be allocated to the following categories:**

- 1. the continuous component**
- 2. the transient component**
- 3. the subtransient component**

**These categories are determined by the electromagnetic process that occurs in the generator. For most fault studies, the representation and calculation of the short circuit characteristics are based on a constant voltage and on the assumption that the decay of the ac short-circuit current is due to an increase in the generator reactances from**

	<b>(1)</b>	<b>the subtransient reactance</b>	<b><math>X_d''</math></b>
<b>to</b>	<b>(2)</b>	<b>the transient reactance</b>	<b><math>X_d'</math></b>
<b>and finally</b>	<b>(3)</b>	<b>the synchronous reactance</b>	<b><math>X_d</math></b>



Therefore, the fault current for the three conditions may be calculated as:

;

If this approximation is acceptable, then the analysis previously developed is applicable by merely using the appropriate value of generator impedance. Otherwise, a full system transient analysis is required which involves considerable computing time.

## **Synchronous and Induction Motor Loads**

**For a short-circuit period of  $T \leq 0.2s$ , synchronous motors can be treated in the same manner as synchronous generators. In a larger short-circuit period, the machine is subjected to a speed drop and is then operating in an asynchronous mode. High and low voltage motors similarly make a contribution to the short-circuit current. However, due to differences in their construction, this contribution decays very rapidly.**

**Short-circuit analysis is generally preceded by data collection and the preparation of a one-line diagram, followed by the determination of the exact objectives of the study. Table 2 gives an indication of parameter values to be used under certain circumstances.**

Item of Plant:	Momentary Level	Interruption Level	Longer Duration Assessment
Induction Motors	$X_d'', R$	-	-
Synchronous Motors	$X_d'', R$	$X_d, R$	-
Synchronous Generators	$X_d'', R$	$X_d', R$	$X_d$
Other Plant: Lines etc	$X_s, R$	$X_s, R$	$X_s, R$

**Table 2**