

Representation of Short & Medium Transmission Lines

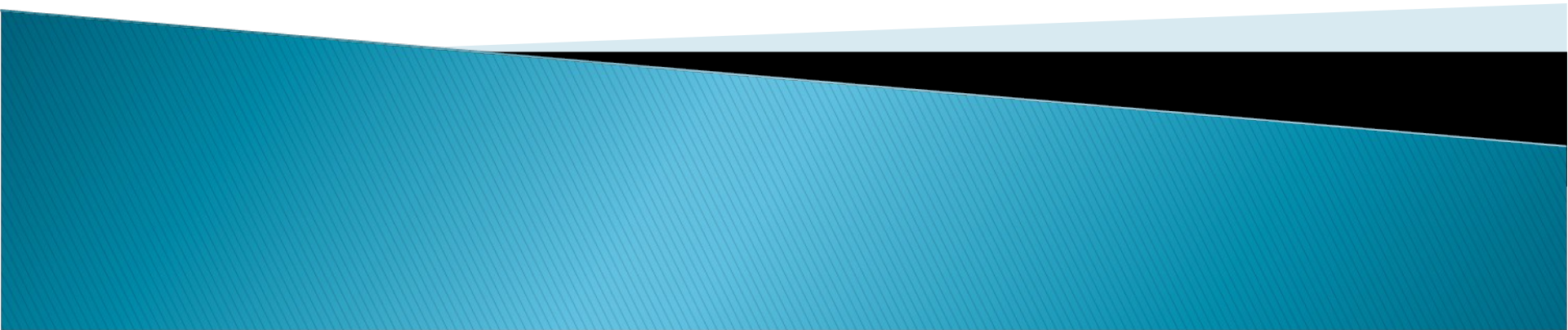
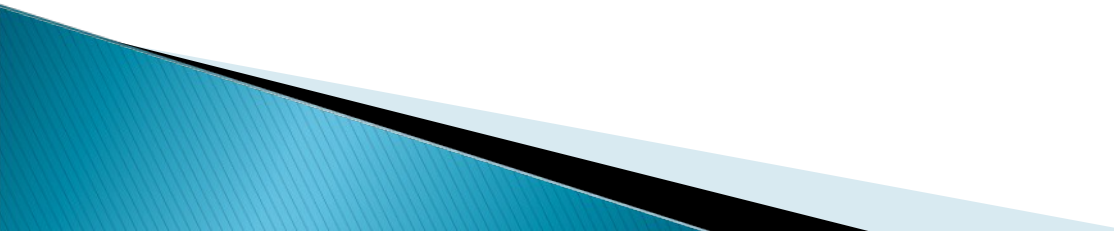

Introduction

- ✓ Classification of overhead transmission lines.
 - ✓ Short transmission lines.
 - ✓ Medium transmission lines.
- 

Classification of Overhead Transmission Lines

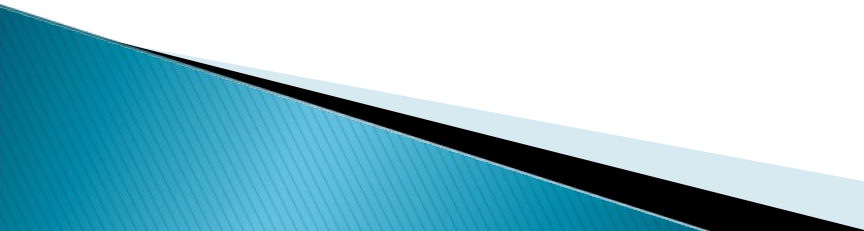
- A transmission line has three constants R , L and C distributed uniformly along the whole length of the line.
 - The resistance and inductance form the series impedance.
 - The capacitance existing between conductors for 1-phase line or from a conductor to neutral for 3-phase line forms a shunt path through the length of the line.
 - Therefore, capacitance effects introduce complications in transmission line calculations.
- 

- Depending upon the manner in which capacitance is taken into account, the overhead transmission lines are classified as.

Sr no.	Line	Length	Voltage	Parameter
1	Short	50 Miles 80 KM.	11 & 33 KV	R & L
2	Medium	50-100 Miles 80-160 KM.	66 & 132 KV	R, L & C
3	Long	Above 100 Miles Above 160 KM	Above 132 KV.	R, L & C

Important terms

❖ Voltage regulation :-

When a transmission line is carrying current, there is a voltage drop in the line due to resistance and inductance of the line.

- ✓ The result is the receiving end voltage (V_r) of the line is generally less than the sending end voltage (V_s).
- ✓ This voltage drop ($V_s - V_r$) in the line is expressed as a percentage of receiving end voltage V_r and is called voltage regulation.
- ✓ Mathematically:-

%age voltage regulation:- $V_s - V_r$

$$\frac{V_s - V_r}{V_r} \times 100$$

❖ Transmission efficiency:-

The power obtained at the receiving end of a transmission line is generally less than the sending end power due to losses in the line resistance.

- ✓ The ratio of receiving end power to the sending end power of a transmission line is known as the transmission efficiency of the line.
- ✓ %age Transmission efficiency:-

$$\frac{\text{Receiving end power}}{\text{Sending end power}} \times 100$$

Performance of single phase short transmission lines

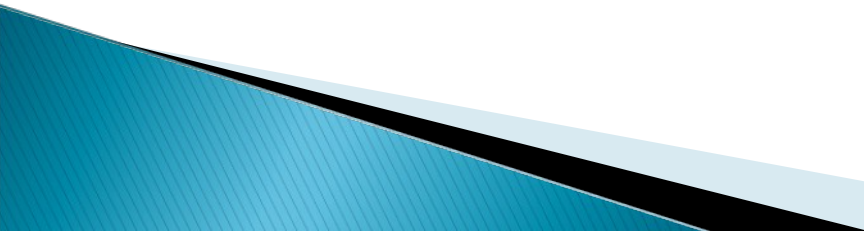
- ▶ As stated earlier, the effects of the line capacitance are neglected for a transmission line.
 - ▶ Therefore while studying the performance of such a line only resistance and inductance of the line are taken into account.
 - ▶ The equivalent circuit of single phase short transmission line is shown in fig.
 - ▶ Here the total resistance and inductance are shown as concentrated or lumped instead of being distributed.
 - ▶ The circuit is a simple a.c. circuit.
- 

Let

I = load current

R = loop resistance *i.e.*, resistance of both conductors

X_L = loop reactance

V_R = receiving end voltage

$\cos \phi_R$ = receiving end power factor (lagging)

V_S = sending end voltage

$\cos \phi_S$ = sending end power factor

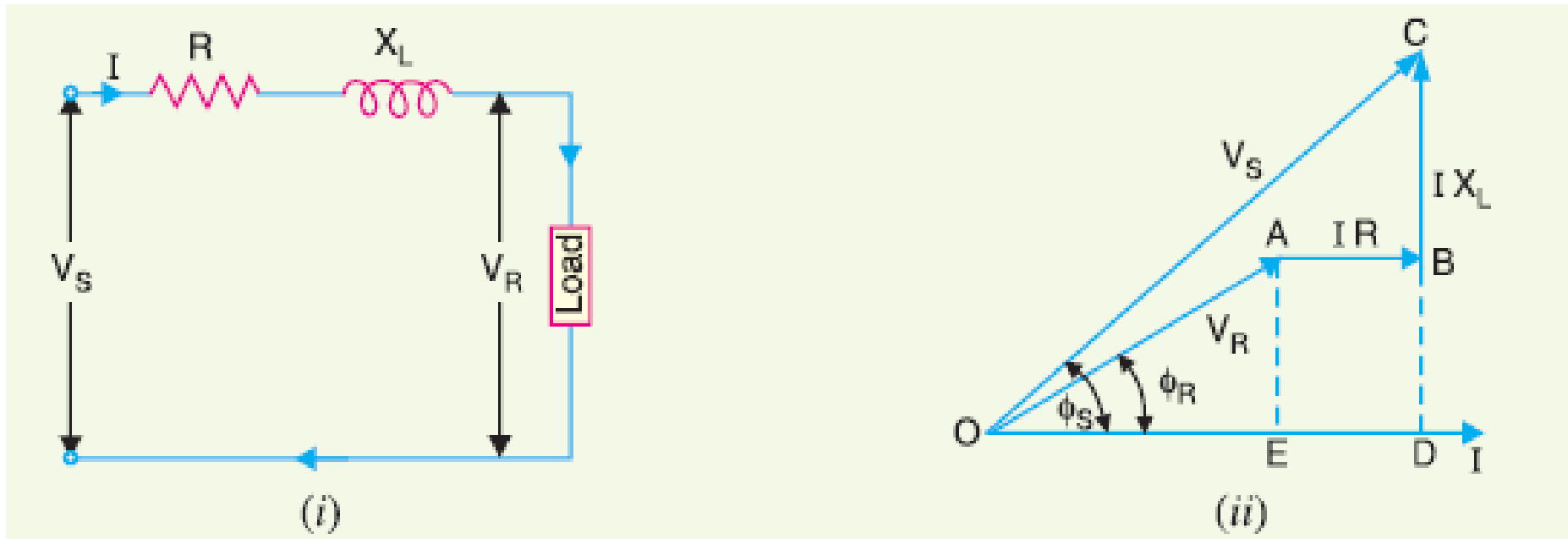

The phasor diagram of the line for lagging load power factor is shown in. fig from the right angle triangle ODC, we get

$$(OC)^2 = (OD)^2 + (DC)^2$$

or
$$V_S^2 = (OE + ED)^2 + (DB + BC)^2$$
$$= (V_R \cos \phi_R + IR)^2 + (V_R \sin \phi_R + IX_L)^2$$

$$\therefore V_S = \sqrt{(V_R \cos \phi_R + IR)^2 + (V_R \sin \phi_R + IX_L)^2}$$

(i) %age Voltage regulation $= \frac{V_S - V_R}{V_R} \times 100$

(ii) Sending end *p.f.*, $\cos \phi_S = \frac{OD}{OC} = \frac{V_R \cos \phi_R + IR}{V_S}$

(iii) Power delivered $= V_R I_R \cos \phi_R$

$$\text{Line losses} = I^2 R$$

$$\text{Power sent out} = V_R I_R \cos \phi_R + I^2 R$$

$$\% \text{age Transmission efficiency} = \frac{\text{Power delivered}}{\text{Power sent out}} \times 100$$

$$= \frac{V_R I_R \cos \phi_R}{V_R I_R \cos \phi_R + I^2 R} \times 100$$

Three-phase short transmission line

- ▶ for reasons associated with economy, transmission of electric power is done by 3-phase system.
 - ▶ This system may be regarded as consisting of three single phase units, each wire transmitting one-third of the total power.
 - ▶ As a matter of convenience, we generally analyse 3-phase system by considering one phase only.
 - ▶ Therefore expression for regulation, efficiency etc. derived for a single phase line can also be applied to a 3-phase system.
 - ▶ Since only one phase is considered, phase value of 3-phase system to be taken.
- 

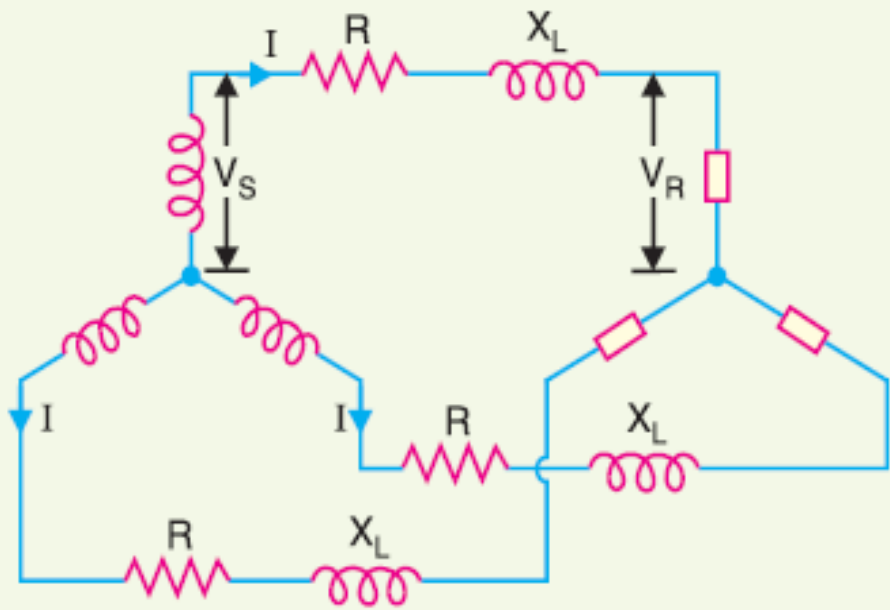

(i)

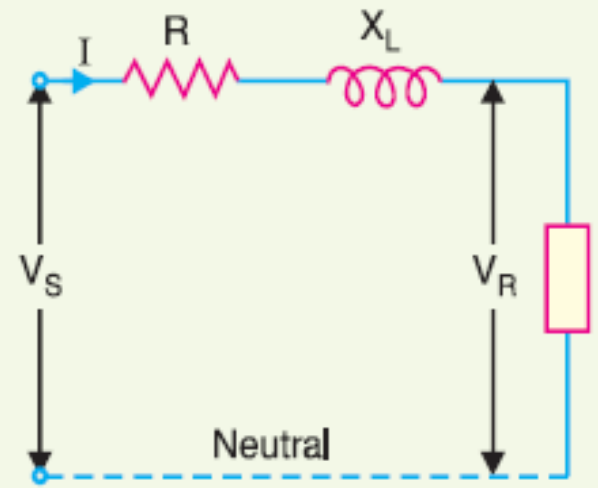

(ii)

- Shows a Y-connected generator supplying a balanced Y-connected load through a transmission line.
- Each conductor has a resistance of $R\Omega$ and inductive reactance of $X_L\Omega$.

Medium transmission lines

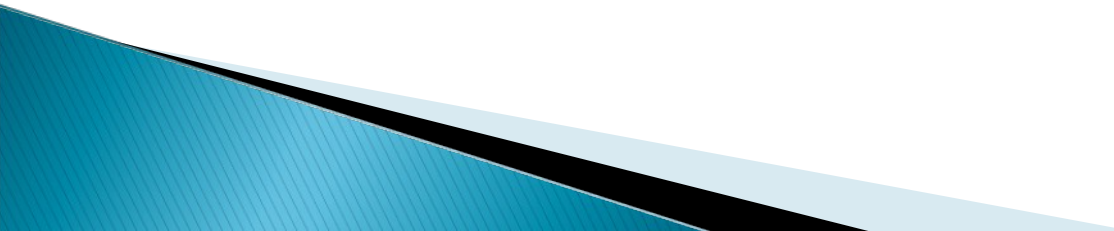
- ▶ In short transmission line calculations, the effect of the line capacitance are neglected because such lines have smaller lengths and transmit power at relatively low voltage.
 - ▶ Since medium transmission lines have sufficient length and usually operate at voltages greater than 20KV, the effect capacitance cannot be neglected.
 - ▶ Therefore in order to obtain reasonable accuracy in medium transmission line calculations, the line capacitance must be taken into consideration.
- 

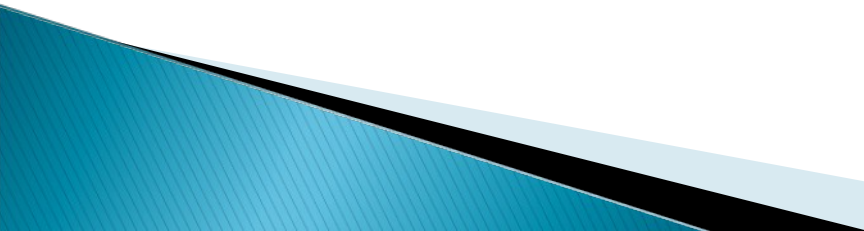
- ▶ The capacitance is uniformly distributed over the entire length of the line.
 - ▶ However, in order to make the calculations simple, the line capacitance is assumed to be lumped or concentrated in the form of capacitor shunted across the line at one or more points.
 - ▶ The most commonly used methods for the solution of medium transmission are.
 - 1) End condenser method
 - 2) Nominal T method
 - 3) Nominal π method
- 

End condenser method

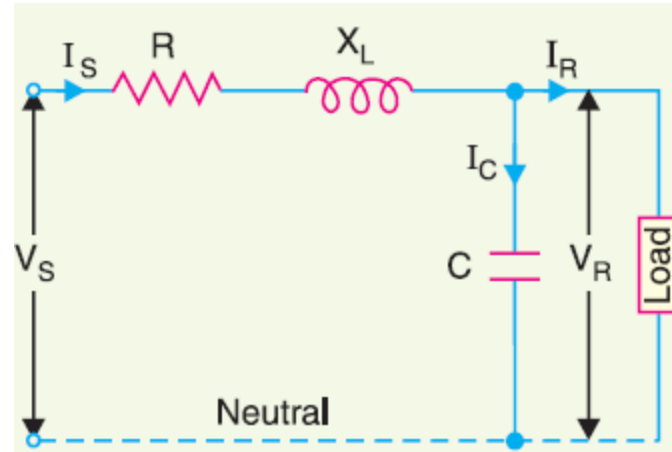

In this method, the capacitance of the line is lumped or concentrated at the receiving or load end as shown in fig.

Nominal T method

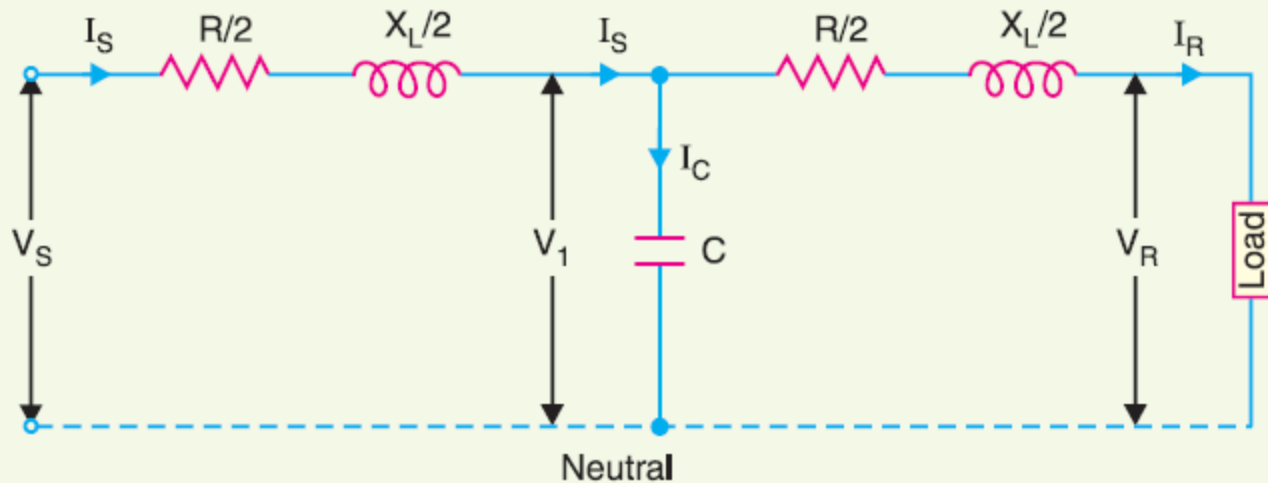

In this method, the whole line capacitance is assumed to be concentrated at the middle point of the line and half the line resistance and reactance are lumped on its either side as shown in fig.

Nominal π method

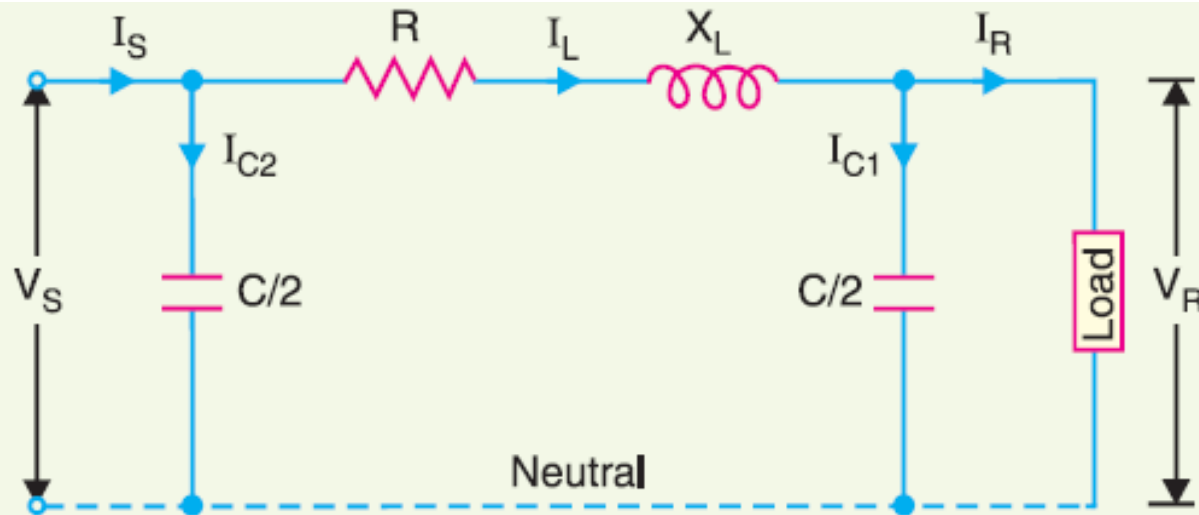

In this method, the capacitance of each conductor is divided into two halves; one half being lumped at the sending end and the other half at the receiving end as shown in fig.

Thank u

