

INDUCTION GENERATOR FOR WIND POWER

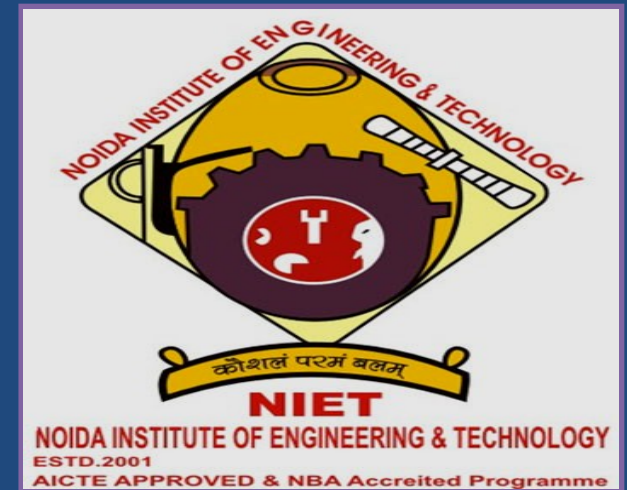

Presented By:-

VIKAS GUPTA

EN – 6(B)

GENERATION

1113321121

OUTLINE

- ❖ Introduction
- ❖ History
- ❖ Wind turbines
- ❖ Working
- ❖ Controlling
- ❖ Advantages of variable speed generation
- ❖ Formula used
- ❖ Why induction generator?

INTRODUCTION

- ❖ Wind turbines convert the kinetic energy present in the wind into mechanical energy by means of producing torque.
- ❖ Large scale wind power projects are an attractive alternative to conventional capacity expansion.
- ❖ In the present scenario , most wind turbine manufacturers now equip power generating units by induction generators.
- ❖ They are operated either at fixed speed or variable speed.
 - *Generators driven by fixed speed turbines can directly be connected to grid.*
 - *Variable speed generators need a **power electronic converter interface** for interconnection with the grid.*
- ❖ Variable speed generation is preferred over fixed speed generation.

HISTORY



In 200 B.C.E., in ancient Persia, earliest windmills were used to grind grains.

These early devices consisted of one or more vertically-mounted wooden beams, on the bottom of which was a grindstone, attached to a rotating shaft that turned with the wind.

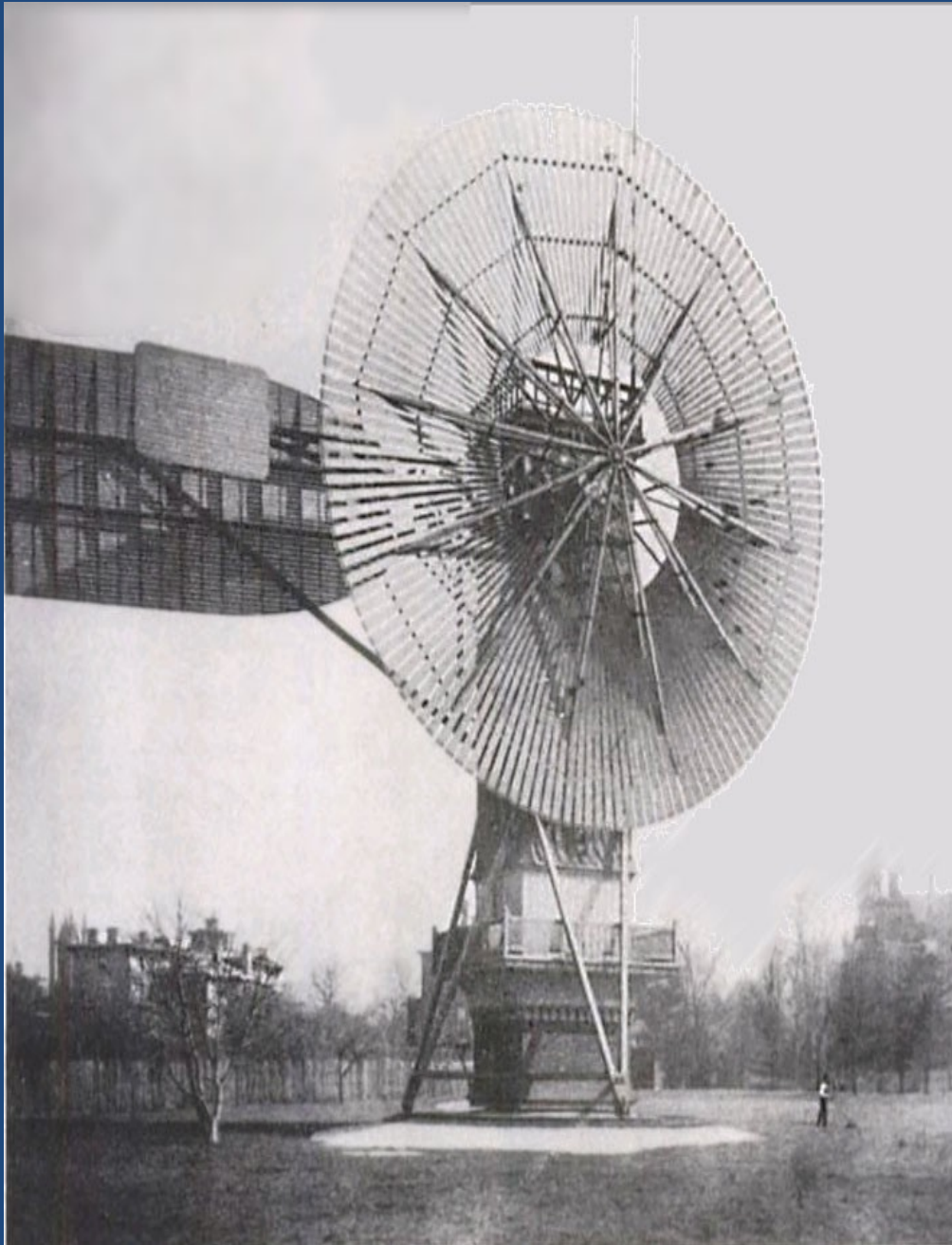

The first automatically operated wind turbine was built in Cleveland in **1887** by *Charles F. Brush*.

It was 60 feet tall, weighed 4 tons and powered a 12 kW generator.

WIND TURBINE

- ❖ A wind turbine is a device that converts kinetic energy from the wind into electrical power.
- ❖ **Aerodynamic modeling** is used to determine the optimum tower height, control systems, number of blades and blade shape.
- ❖ A quantitative measure of the wind power available at any location is called **Wind Power Density(WPD)**.
- ❖ Wind turbines are generally classified depending on their **axis of rotation** as:
 - *Horizontal axis type and,*
 - *Vertical axis type.*

TYPES OF WIND TURBINE

Horizontal Axis Wind Turbine



Vertical Axis Wind Turbine



PARTS OF WIND TURBINE

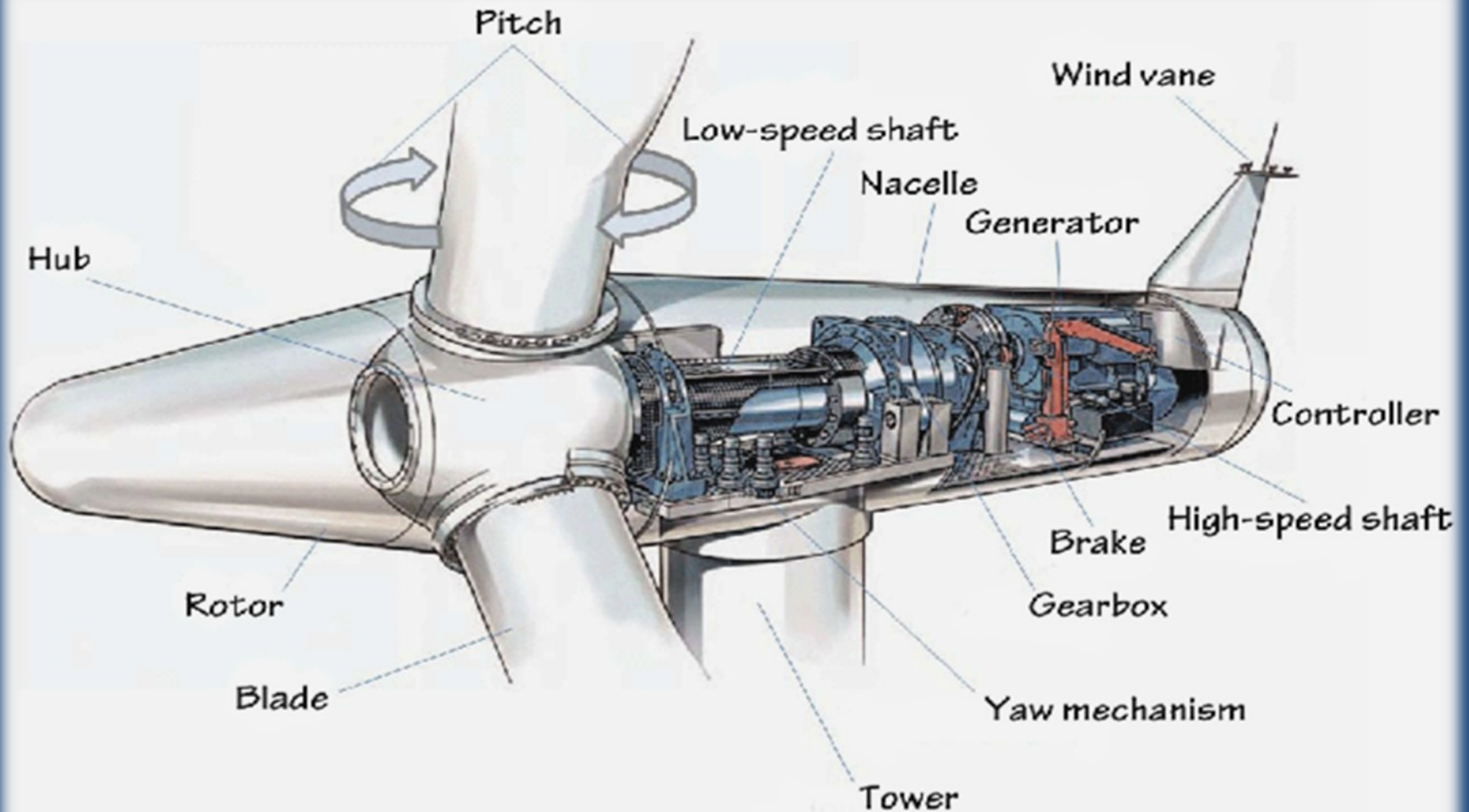

WIND POWER DEVELOPED BY THE WIND TURBINE
IS GIVEN BY :

$$\text{POWER} = (0.5 \times C_p \times A \times \rho \times V^3)$$

where,

C_p: Power coefficient

A: Area swept by rotor blades

ρ: Air density

V: Velocity of wind(in mph)

VARIABLE SPEED WIND ENERGY CONVERSION SYSTEM

In variable speed systems, the turbine's rotor absorbs the mechanical power fluctuations by changing its speed.

So the output power curve is smoother which greatly enhances the quality of power.

However, since **variable speed operation produces a variable frequency voltage**, a power electronic converter must be used to connect to the constant frequency grid.

It can be achieved by using:

- WECS with **Squirrel cage** induction generator.
- WECS with **Wound rotor** induction generator.
- WECS with **Doubly-fed** induction generator.

WECS with Squirrel cage induction generator

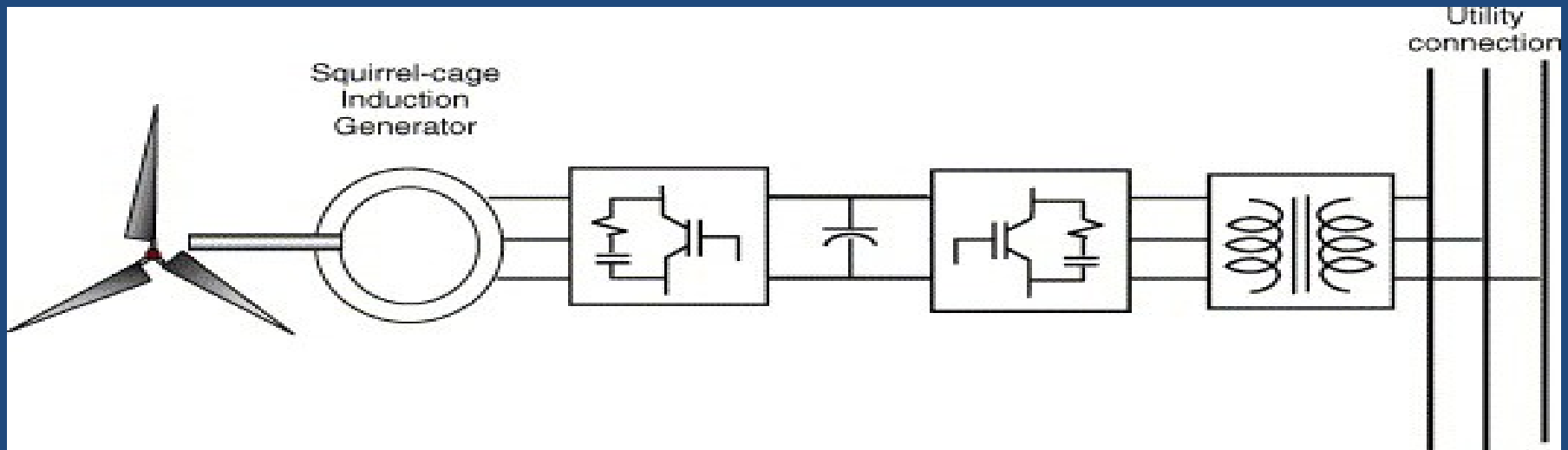

In this set up the stator of the squirrel cage induction generator will be connected to the grid by the means of **back to back connected power electronic converter bridges**.

Since the power converter has to convert all the stator power, **the converter size depends on the stator power rating**.

ADVANTAGE:

- Ability to make the best use of available wind power.
- It eliminates the need for a capacitor bank.

DISADVANTAGE:

- Cost of power converter is high.

WECS with Wound rotor induction generator

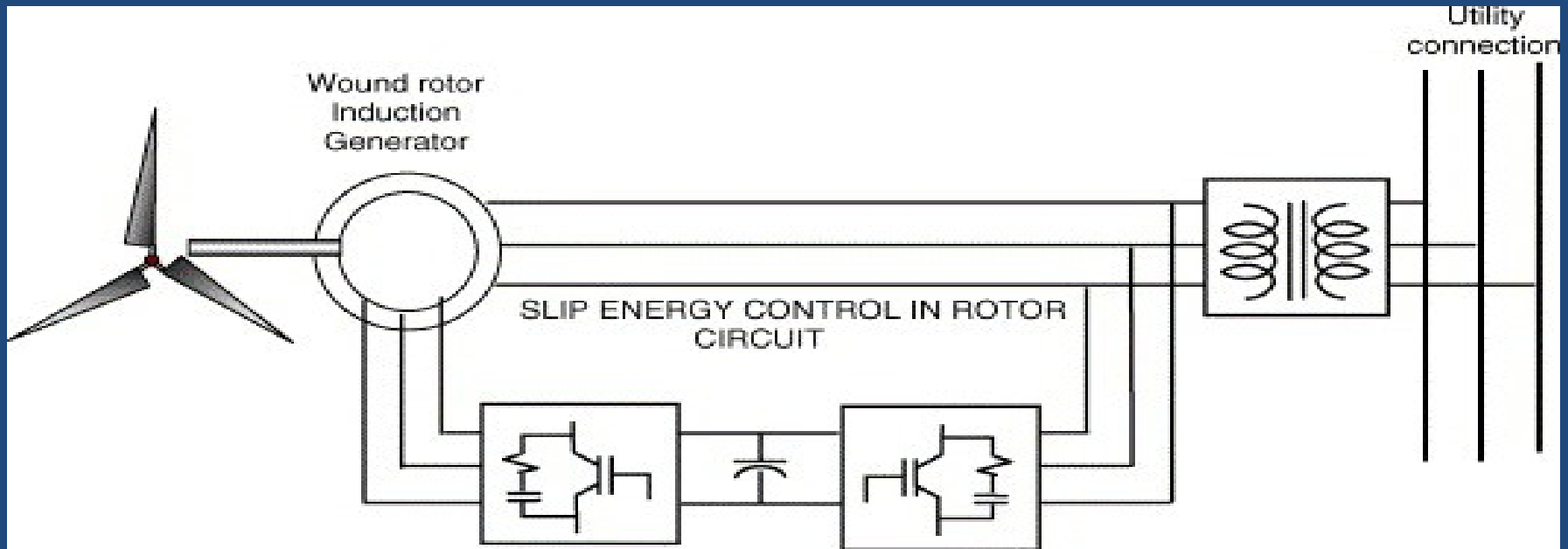

The power converter size in the earlier system can be reduced by using it on the rotor side of a wound rotor induction generator.

The power converter is now connected between the rotor and grid , so it needs to carry only the slip power.

ADVANTAGES:

➤ For utility scale wind power generation it outweighs squirrel cage machine.

WECS with DFIG

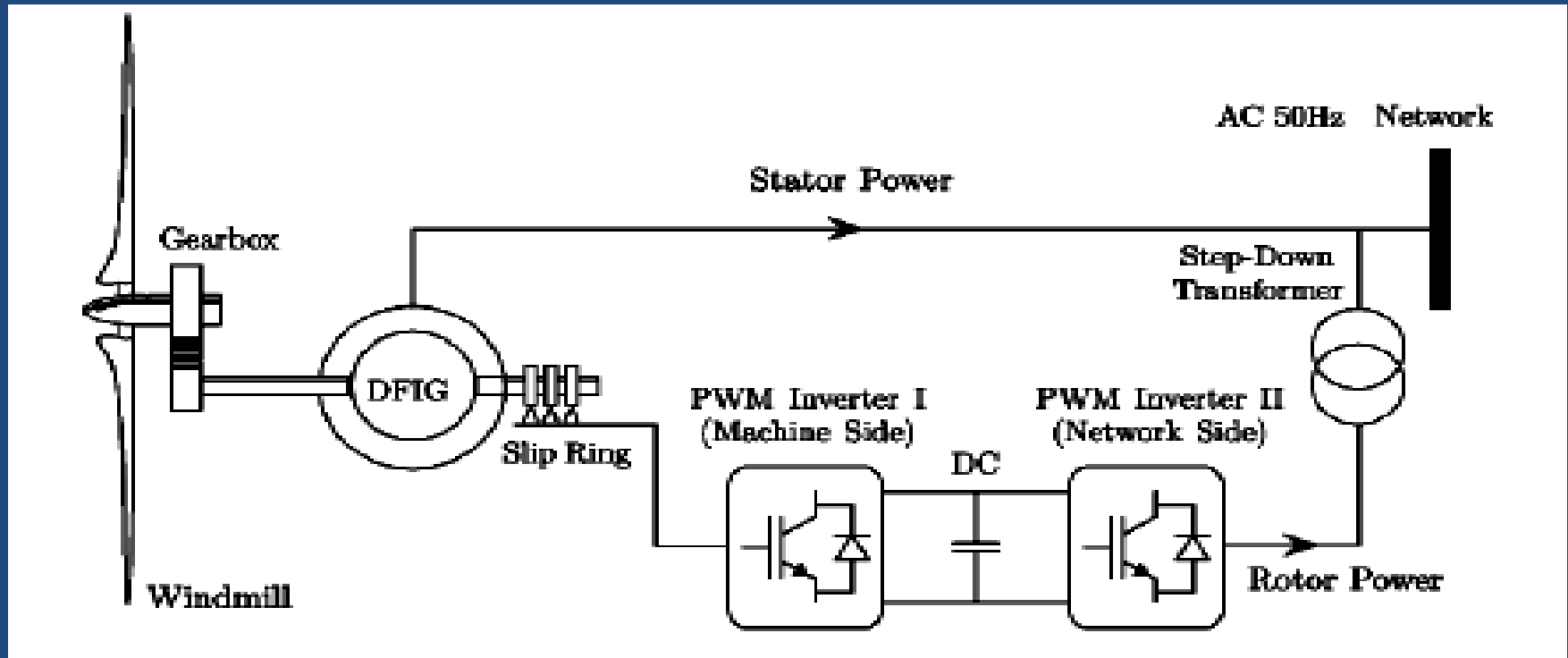

Double-fed induction machines can be operated as a generator as well as a motor in both sub-synchronous and super-synchronous speeds, thus giving four possible operating modes.

Only the two generating modes at sub-synchronous and super-synchronous speeds are of interest for wind power generation.

BACK TO BACK CONNECTED POWER CONVERTER BRIDGES

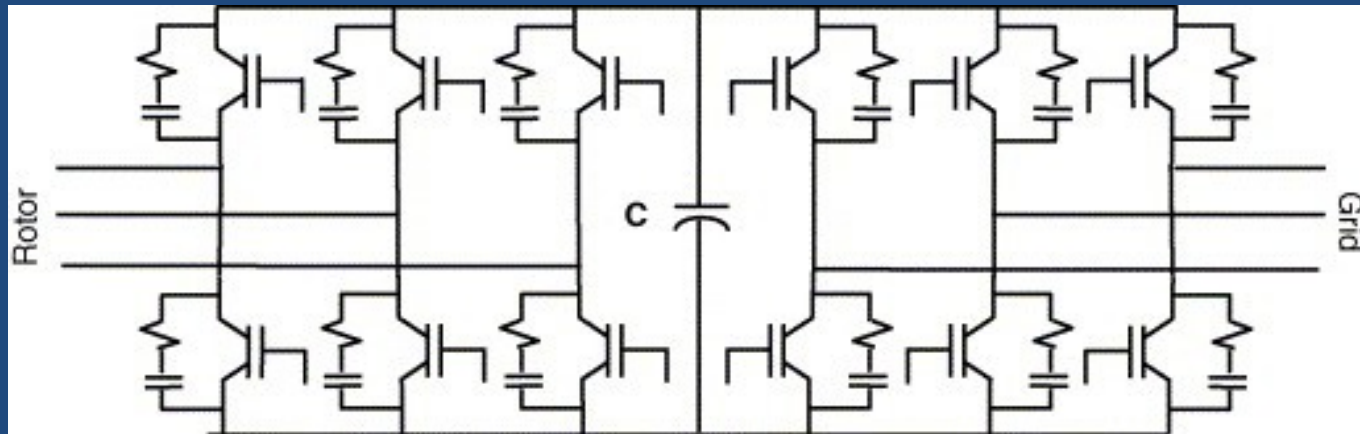

Two power converter bridges connected back-to-back by means of a dc link can accommodate the bidirectional rotor power flow in a DFIG.

The purpose of the grid side converter is to maintain the dc link voltage constant.

It has control over the active and reactive power transfer between the rotor and the grid.

The rotor side converter is responsible for control of the flux, and thus, the stator's active and reactive powers .

ADVANTAGES:

- Less cost of AC-AC converter.
- Improved system efficiency.

CONTROLLING

Induction generator control:

- Cage rotor induction generators can be made to operate over a wider speed range by ***pole changing or pole amplitude modulation(PAM) of the main winding.***
- A Wound rotor induction generator can be controlled by varying the slip energy of the rotor circuit using following methods : ***rotor resistance control , cascading*** etc.

Transmission control:

- By using ***silicon controlled rectifier(SCR)*** device ,i.e. by applying delayed trigger pulses.

Load control:

- Using ***switched load resistors*** stepwise; load approximation can be made.

WHY INDUCTION GENERATOR?

- ***Simple and robust construction.***
- ***Can run independently.***
- ***Inexpensive.***
- ***Minimal maintenance.***
- ***Inherent overload protection.***
- ***At high speed, reduces size and weight of machine, and filter components.***

Thank you!

Q U E S T I O N S ?

