

The background features a dark blue gradient with faint, light blue technical diagrams. On the left, there are circular gauges with numerical scales (140, 150, 160, 170, 230, 240, 250, 260) and arrows. On the right, there are circular arrows and dashed lines, suggesting a process or cycle. A central horizontal band is a solid purple color, containing the title text in a blue, outlined font.

Kinetics Of Multi-substrate Enzyme Catalyzed Reaction

Enzyme Kinetics

- Enzyme kinetics is the study of the chemical reactions that are catalyzed by enzymes. Enzymes are usually protein molecules that manipulate other molecules, the enzyme's substrates. These target molecules bind to an enzyme's active site and are transformed into products through a series of steps known as the enzyme mechanism. These mechanisms can be divided into:

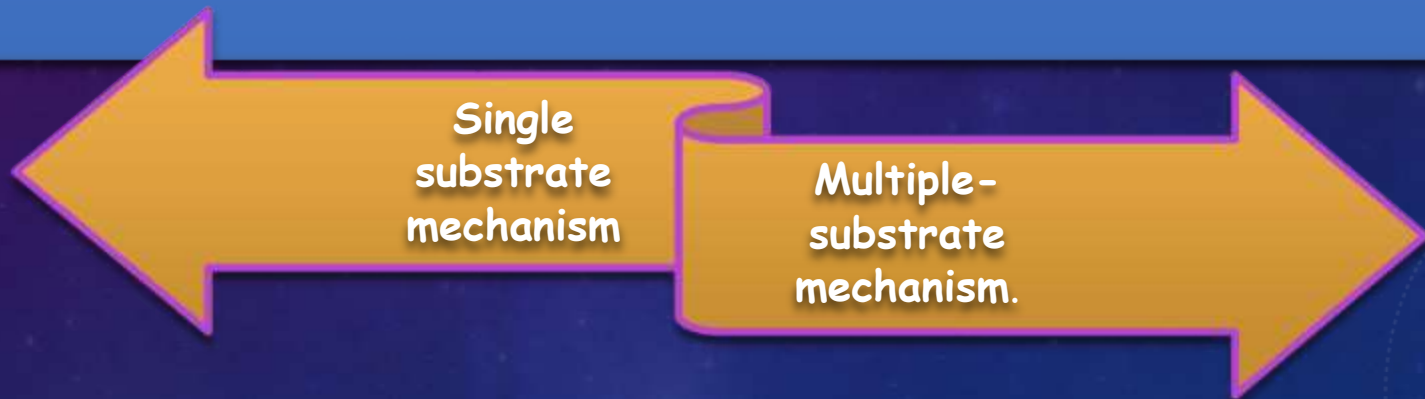

- An essential feature of enzyme-catalyzed reactions is **saturation**: at increasing concentrations of substrates the rate increases and approaches a limit where there is no dependence of rate on concentration. (V_{max})

Multiple-substrate Reactions:

- Involve more than one substrate often resulting in multiple products.
- Known as bi bi reactions (two substrates two products one enzyme)
- The following equation represents a bi bi reaction in which A and B are the substrates, E is the enzyme and P, Q are the products (considering the forward direction).



- Overall reaction does not give a good representation of what actually happens in reality.
- The Multi-Substrate reactions in fact, follow a complex create equations that describe how the substrates bind and in what sequence.
- More information about the enzyme-reagent interaction is obtained when looking at the enzyme mechanism which consists of microscopic reactions

Mechanisms for multi-reactant enzymatic reactions have been classified in some general groups.

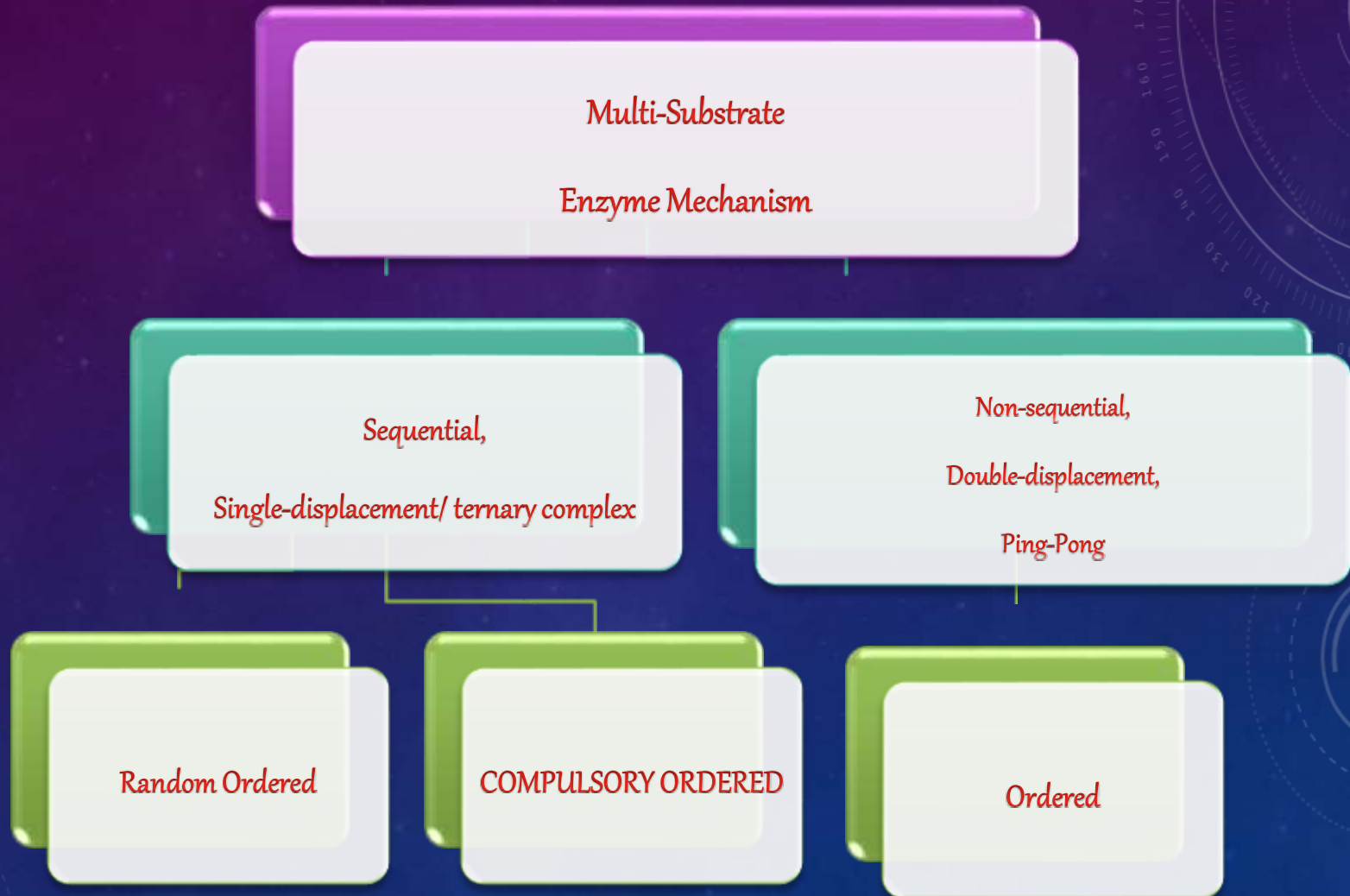

- Often a division is made between sequential mechanisms and non-sequential mechanisms. In the sequential type, both substrates must bind to the enzyme before any product is released.
- The sequential mechanism can be subdivided in: random-order mechanisms, in which the order of binding the substrates is not important, and compulsory-order mechanisms, when the order of binding is important. For bi bi reactions the sequential mechanisms are also called ternary-complex mechanisms because of the ternary EAB/EPQ intermediate.
- Non-sequential mechanisms on the other hand, do not require all the substrates to bind before a product is released and thus a substituted-enzyme intermediate, E^* will be formed. Such mechanisms are generally referred to as ping-pong or substituted-enzyme mechanisms.

Ping Pong/ Non-Sequential Mechanism:

Ping-pong mechanism, also called a double-displacement reaction, is characterized by the change of the enzyme into an intermediate form when the first substrate to product reaction occurs. It is important to note the term intermediate indicating that this form is only temporary. At the end of the reaction the enzyme must be found in its original form.

The Ping Pong mechanism can be shown by following expression

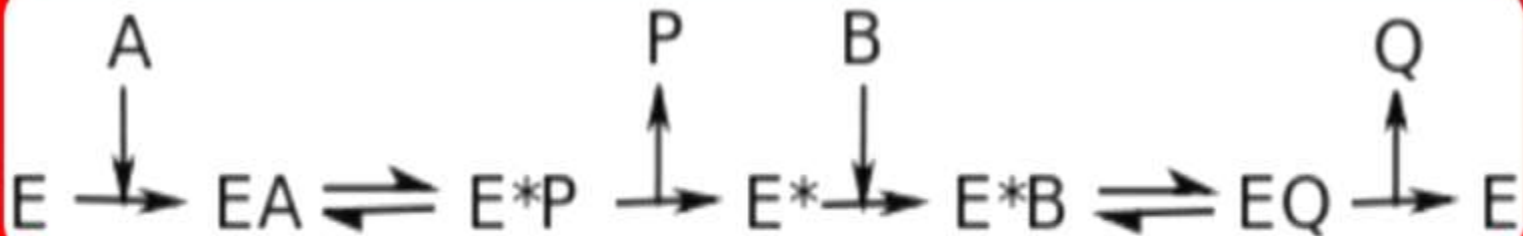

Enzymes with a ping-pong mechanism can exist in two states, E and a chemically modified form of the enzyme E^* ; this modified enzyme is known as an intermediate. In such mechanisms, substrate A binds, changes the enzyme to E^* by, for example, transferring a chemical group to the active site, and is then released. Only after the first substrate is released can substrate B bind and react with the modified enzyme, regenerating the unmodified E form and product Q is released.

For this mechanism, Lineweaver-Burk plots at fixed A and different varying values of B give a series of parallel lines.

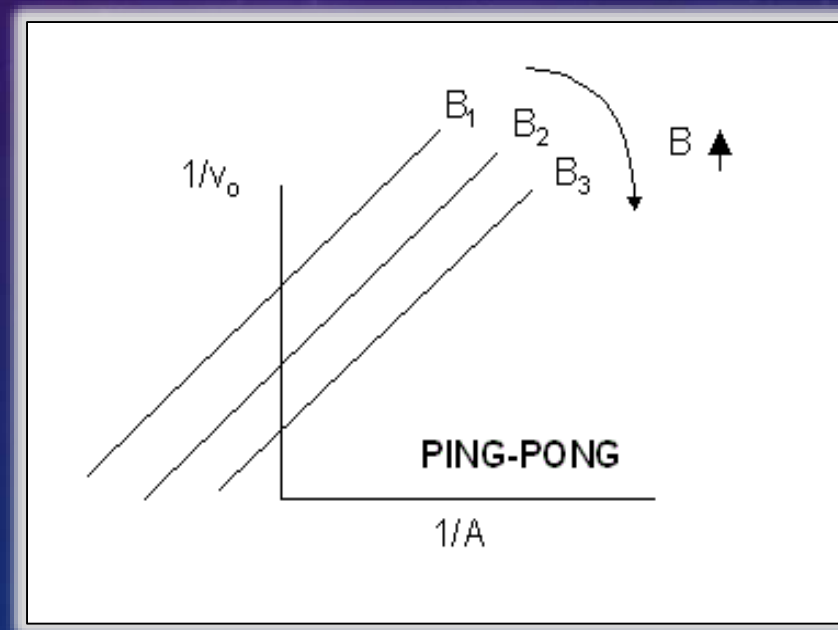

Example Of Ping Pong Mechanism Chymotrypsin

More specifically, chymotrypsin operates through a particular type of ping-pong mechanism called covalent hydrolysis. This means that the enzyme first forms a covalent bond with the target substrate, displacing the more stable moiety into solution. This enzyme-substrate complex is called the enzyme intermediate. The intermediate then reacts with water, which displaces the remaining part of the initial substrate and reforms the initial enzyme

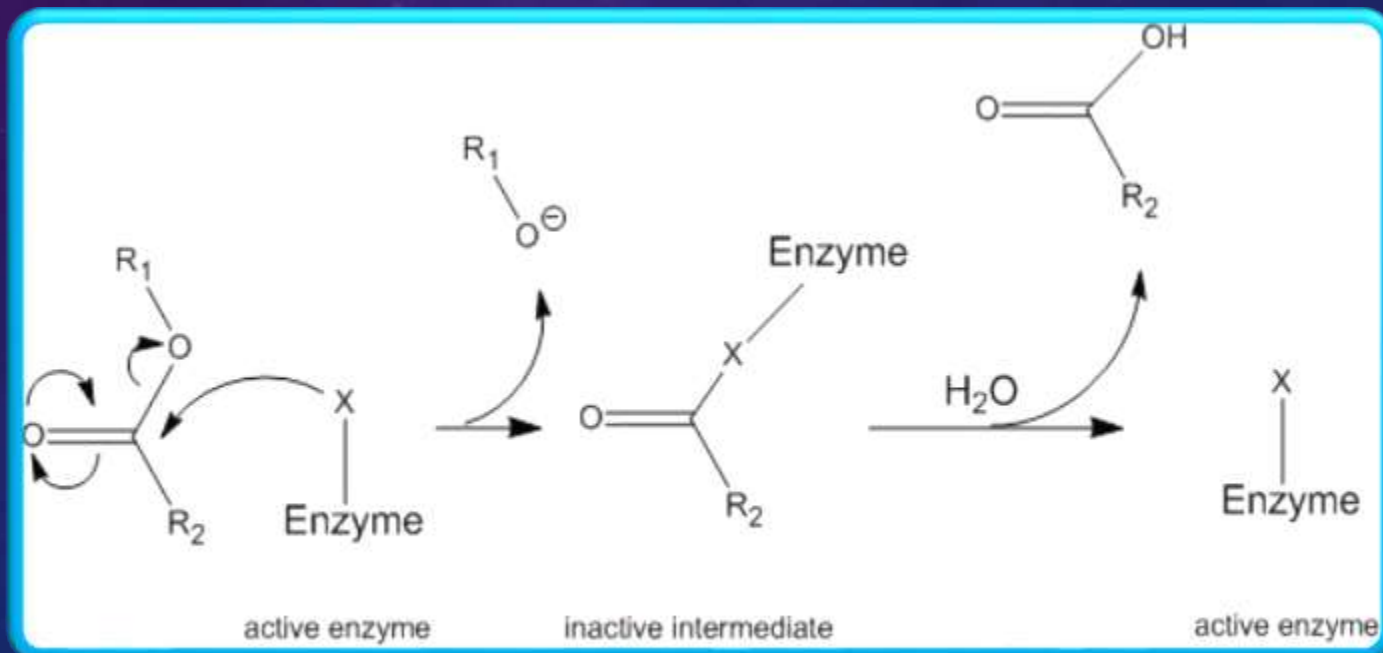

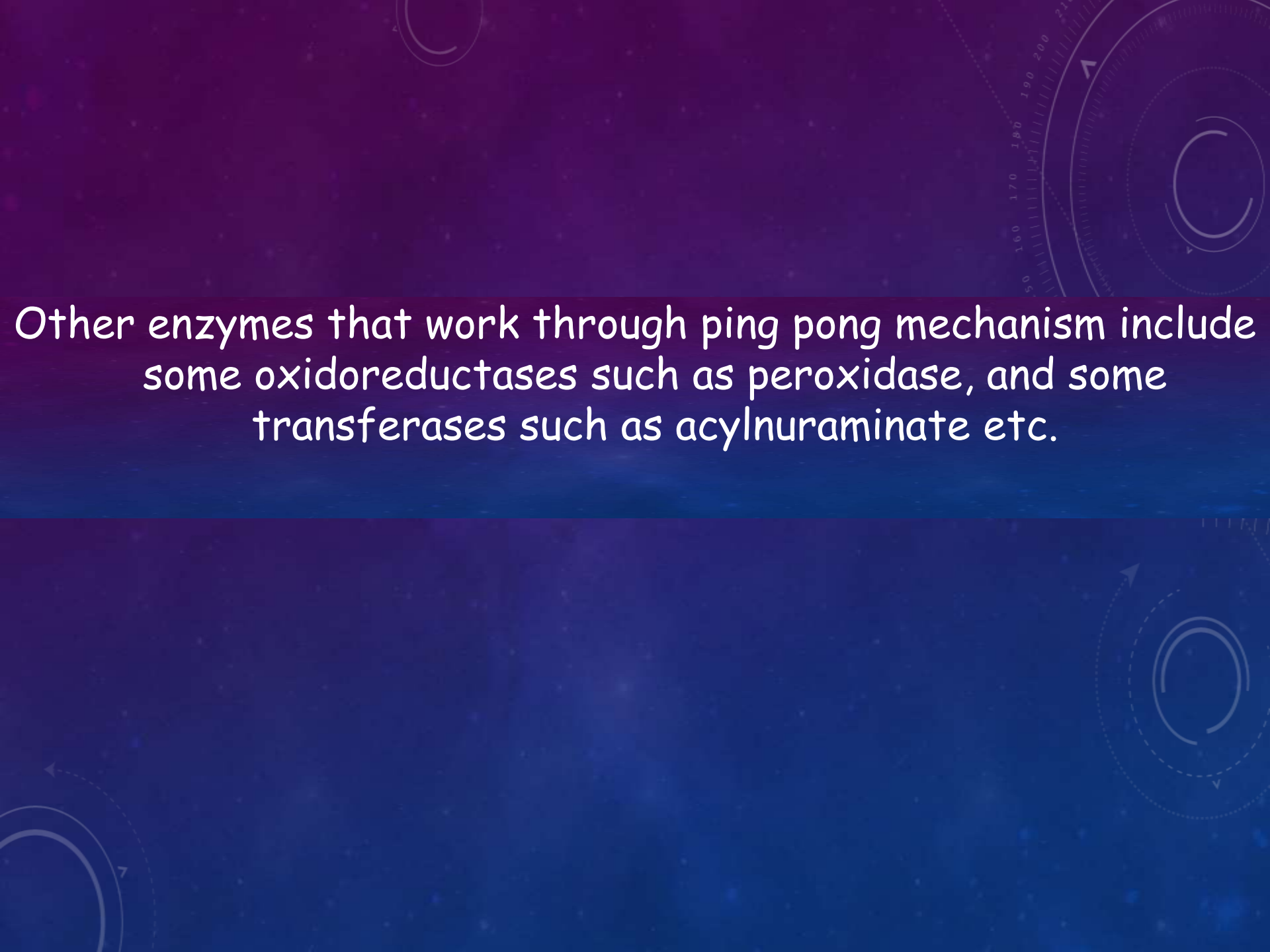
The background features a dark blue gradient with faint, light blue circular patterns and a scale on the right side. The scale has markings for 50, 160, 170, 180, 190, and 200. There are also some dashed lines and arrows forming circular paths.

Other enzymes that work through ping pong mechanism include some oxidoreductases such as peroxidase, and some transferases such as acylneuraminate etc.

Sequential Reaction/Ternary Complex Mechanisms:

In these enzymes, both substrates bind to the enzyme at the same time to produce an EAB ternary complex. The form of an enzyme that exists in solution in the absence of any substrate or other small molecule that can bind to it is called the free enzyme. An intermediate derived from the free enzyme by binding of a substrate molecule is called an enzyme-substrate complex, and terms such as enzyme-product complex, enzyme-inhibitor complex. A complex derived from the free enzyme and one other molecule is called a binary complex; one derived from the free enzyme and two other molecules is called a ternary complex

These mechanisms can be divided into further two types:

- (i) Random order mechanism
- (ii) Compulsory order mechanism

Ordered Sequential Reactions

☀ In ordered sequential reactions, all the substrates are first bound to the enzyme in a defined order or sequence. The products, too, are released after catalysis in a defined order or sequence.

☀ Example:

☀ An example is the lactate dehydrogenase enzyme, which is a protein that catalyzes glucose metabolism. In this ordered mechanism, the coenzyme, NADH, always binds first, with pyruvate binding afterward. During the reaction, the pyruvate is reduced to lactate while NADH is oxidized to NAD⁺ by the enzyme. Lactate is then released first, followed by the release of NAD⁺.

☀ This is a characteristic of a ternary complex, which consists of three molecules that are bound together. Before catalysis, the substrates and coenzyme are bound to the enzyme. After catalysis, the complex consists of the enzyme and products, NAD⁺ and lactate.

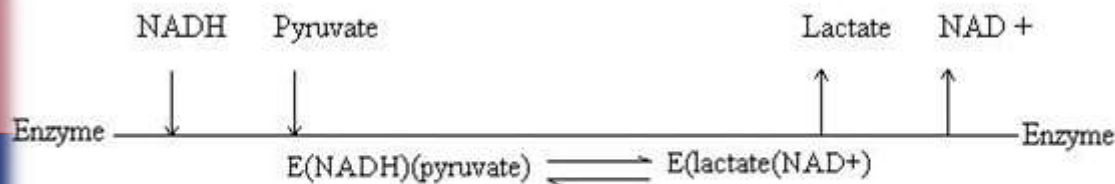

Random Order Mechanism:

- In random sequential reactions, the substrates and products are bound and then released in no preferred order, or "random" order. This mechanism can generally be expressed by following equation:

Where

A, B = Substrates

E = Enzyme

P, Q = Products

Example:

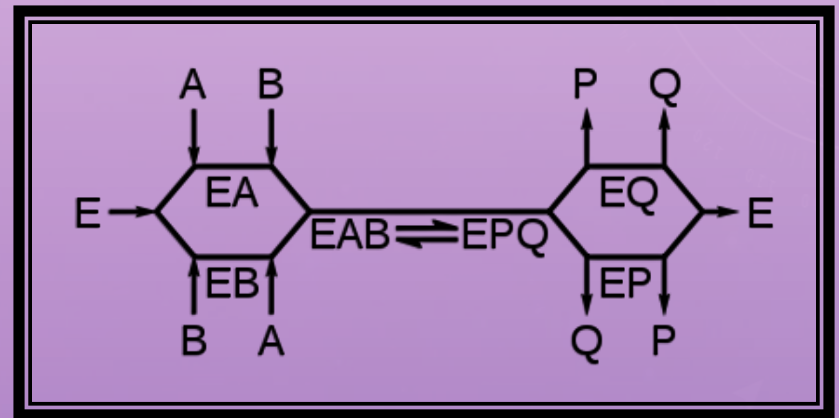

- An example is the creatine kinase enzyme, which catalyzes the substrates, creatine and ATP, to form the products, phosphocreatine and ADP. In this case, either substrates may bind first and either product can be released.
- A ternary complex is still observed for random sequential reactions. Before catalysis, the complex includes the enzyme, ATP and creatine. After catalysis, the complex consists of the enzyme, ADP, and phosphocreatine.

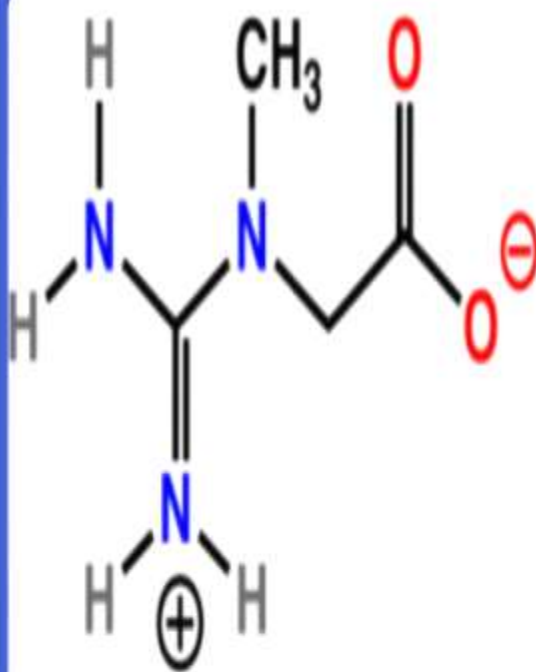

creatine

ATP → ADP



creatine kinase

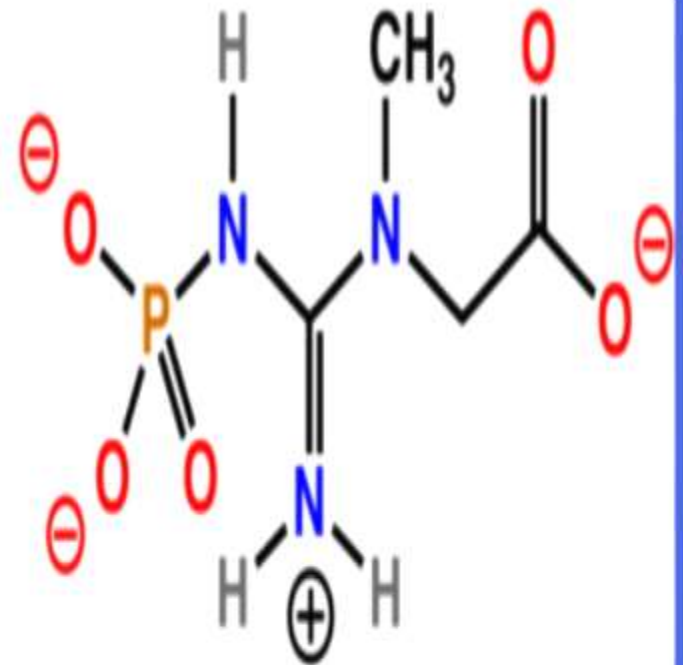

phosphocreatine

creatine

phosphocreatine

Random Order Mechanism

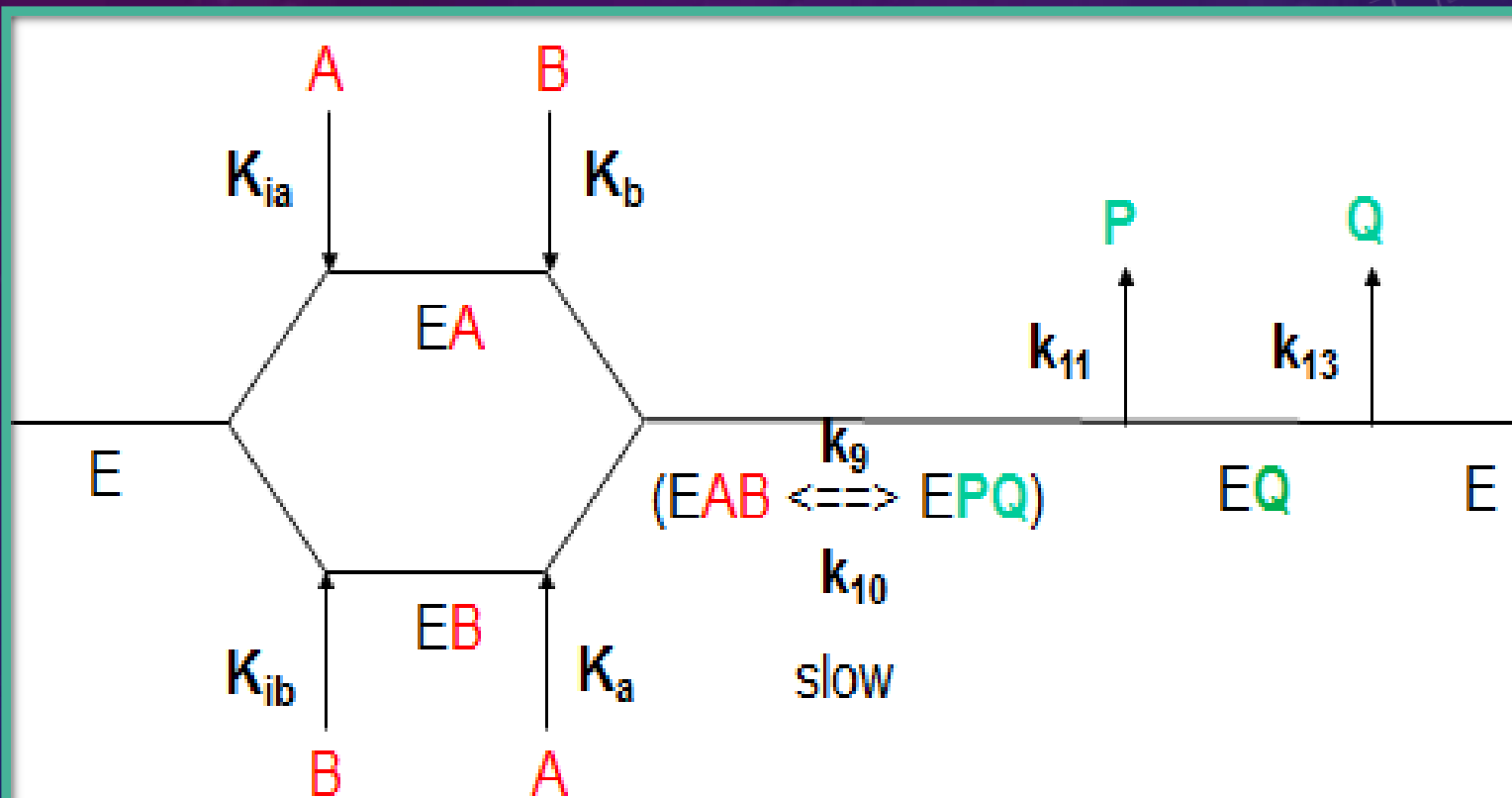

We first find out the values of the constants

These are the values of the reactants over the values of product.

$$k_{ia} = \frac{[E][A]}{[EA]}$$

$$k_{ib} = \frac{[E][B]}{[EB]}$$

$$k_b = \frac{[EA][B]}{[EAB]}$$

$$k_a = \frac{[EA][A]}{[EAB]}$$

As we represented the total value of enzyme through E_0 . So it equals to

1

$$\underline{E_0 = E + EA + EB + EAB}$$

Here

E = It represents the value of the enzyme present in free form

EA = It represents the value of the enzyme that bound with substrate A

EB = It represents the value of the enzyme that bound with substrate B

EAB = Enzyme in bound state with both substrate A and substrate B

Now we found out the value of enzymes in different states given as above

Follow the basic mechanism as given above each value of enzyme is equal to the value of the constant multiply with the product formation divided by the reactant. So these values came out.....

$$EA = \frac{k_b[EAB]}{[B]}$$

$$EB = k_a \frac{[EAB]}{[A]}$$

$$E = k_{ia} k_b \frac{[EAB]}{[A][B]}$$

□ The value of E_{0} find out by the help of basic Michaelis-Menten equation. Putting the values of the E_{A} , E_{B} and E in equation (1), we get

$$E_{0} = E + E_{A} + E_{B} + E_{AB}$$

$$E_{0} = k_{ia} k_{b} \frac{[EAB]}{[A][B]} + \frac{k_{b} [EAB]}{[B]} + \frac{k_{a} [EAB]}{[A]} + E_{AB}$$

2

□ On the right hand side of the equation E_{AB} is common in all factors so we take it as common

$$E_{0} = \left(\frac{k_{ia} k_{b}}{[A][B]} + \frac{k_{b}}{[B]} + \frac{k_{a}}{[A]} + 1 \right) (E_{AB})$$

3

□ As we know that $E_{0} K_{cat} = V_{max}$ and $(E_{AB}) K_{cat} = V_{0}$

□ Multiply both sides of the equation by K_{cat} ,

$$(k_{cat}) E_{0} = \left(\frac{k_{ia} k_{b}}{[A][B]} + \frac{k_{b}}{[B]} + \frac{k_{a}}{[A]} + 1 \right) (E_{AB}) (k_{cat})$$

4

□ So put these values of V_{max} and V_o in equation 4

$$E_0 K_{cat} = V_{max} \\ (EAB) K_{cat} = V_o$$

$$V_{max} = \left(\frac{k_{ia} k_b}{[A][B]} + \frac{k_b}{[B]} + \frac{k_a}{[A]} + 1 \right) V_o$$

5

□ Divide the right factors on left hand side in order to find out the value of V_o

$$V_o = \left(\frac{V_{max}}{\frac{k_{ia} k_b}{[A][B]} + \frac{k_b}{[B]} + \frac{k_a}{[A]} + 1} \right)$$

□ Now take the L.C.M of the denominator of the right hand side and the denominator of the denominator with numerator so AB would be written with V_{max} , equation number 6 would be like this

$$V_o = \left(\frac{V_{max} AB}{(k_{ia} k_{iab} + k_b A + k_a B + AB)} \right)$$

6

K_{ib} does not appear in the final equation. Assuming rapid equilibrium, $K_{ia}K_b = K_{ib}K_a$.
The following equation can be derived from Ping-Pong bi-bi mechanism

$$V_o = \left(\frac{V_{max} AB}{(k_b A + k_a B + AB)} \right)$$

For simplicity, all of the enzyme kinetic equations have been derived assuming no products are present.

By inspection, there would appear to be two types of "effective" dissociation constants for reactant A. One describes the binding of A to E (K_{ia}) and the other the binding of A to EB (K_a). Using mass balance for E and relationship that $v_o = k_{cat} [EAB]$, the following initial rate equation can be derived. Here K_{ia} is the apparent dissociation constant for A.

Pre Steady State Kinetics

- ✿ The pre-steady-state in enzyme-catalyzed reactions occupies very short period of time usually fractions of a second and very low product concentrations. For reactions that are not too fast the stopped-flow techniques can be used to measure easily the rate of reaction as compare to fast orders reaction.
- ✿ For reactions that have to be studied over periods of less than 1 minute relaxation techniques are used. In these techniques the system is disturbed, usually but not necessarily from a state of equilibrium, after which it relaxes to equilibrium or a new steady state. In the temperature-jump (T jump) technique the temperature is increased rapidly and the system relaxes to a new state of equilibrium or a new steady state at the final temperature. In the pressure-jump technique the pressure is rapidly changed.

What is Steady State?

A condition of a physical system or device that does not change over time, or in which any one change is continually balanced by another, such as the stable condition of a system in equilibrium.

The general rate equation of Alberty (1953)

- Many two-substrate reactions obey the MM equation with respect to one substrate at constant concentration

$$v = \frac{V_{\max} [AX][B]}{K_m^B [AX] + K_m^{AX} [B] + [AX][B] + K_s^{AX} K_m^B}$$

V_{\max} : max v_o when both AX and B are saturating

K_m^{AX} : [AX] which gives $1/2V_{\max}$ when B is saturating

K_m^B : [B] which gives $1/2V_{\max}$ when AX is saturating

K_s^{AX} : dissociation constant for $E + AX \rightleftharpoons EAX$

$$v = \frac{V_{\max} [AX] [B]}{K_m^B [AX] + K_m^{AX} [B] + [AX] [B] + K_s^{AX} K_m^B}$$

At very large [B]: $v = \frac{V_{\max} [AX]}{[AX] + K_m^{AX}}$

At constant but non saturating [B]: $v = \frac{V_{\max} K_1 [AX]}{[AX] + K_2}$

$$K_1 = \frac{[B]}{K_m^B + [B]} \quad K_2 = \frac{K_s^{AX} K_m^B + K_m^{AX} [B]}{K_m^B + [B]}$$

It works well for reactions using 1 or 2 substrate and producing 1 or 2 products but for more complex reactions, other approaches are used

General rate equation of Dalziel (1957)

$$\frac{[E]}{v} = \phi_0 + \frac{\phi_{AX}}{[AX]} + \frac{\phi_B}{[B]} + \frac{\phi_{AXB}}{[AX][B]}$$

ϕ terms: kinetic coefficients found from primary and secondary plots

- Primary plots of $[E]/v$ versus $1/[AX]$ at constant $[B]$ are drawn for series of different $[B]$
- Secondary plots:
 - Slope vs $1/[B] \rightarrow$ intercept: ϕ_{AX} , slope: ϕ_{AXB}
 - Intercepts vs $1/[B] \rightarrow$ intercept: ϕ_0 , slope: ϕ_B

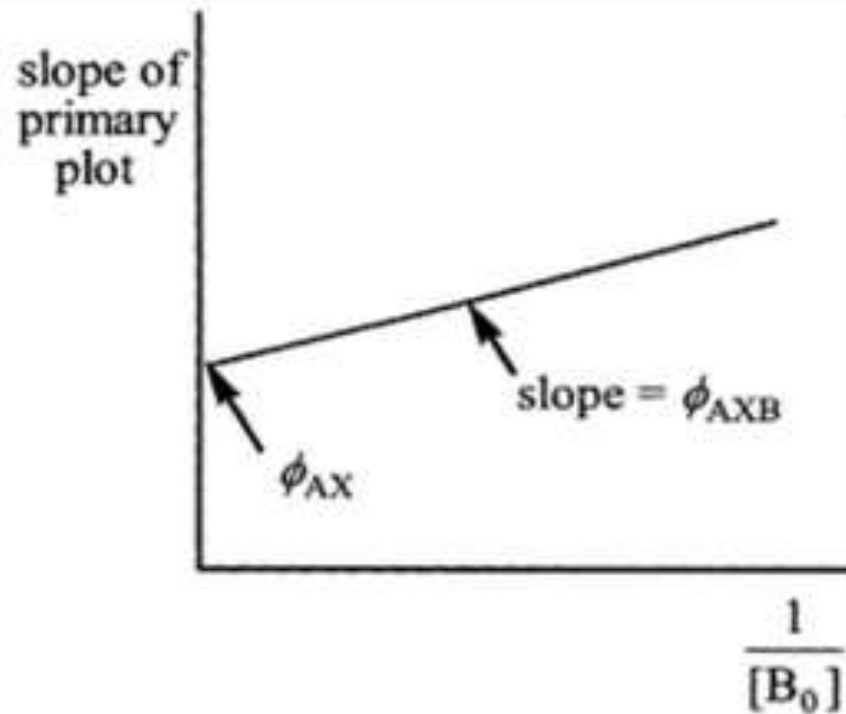
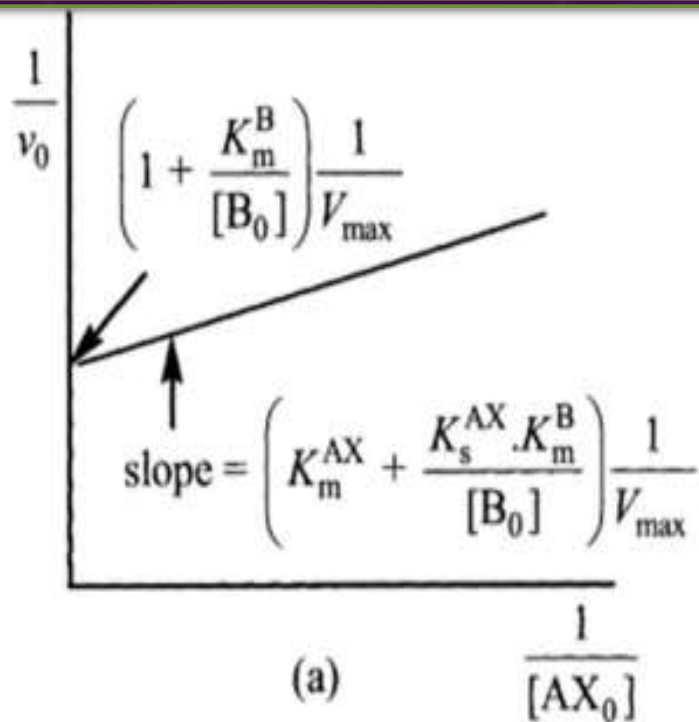

$$v = \frac{V_{\max} [AX][B]}{K_m^B [AX] + K_m^{AX} [B] + [AX][B] + K_s^{AX} K_m^B}$$

Cooperative Kinetics

- Many proteins are known to be oligomer that is they are composed of more than one identical protein subunits.
- For example, phosphofructokinase (E.C 2.7.1.11) from *Escherichia coli* is made of up four identical subunits. Each subunit has at least three binding sites corresponding to sites for ATP, Fructose-6-Phosphate (F6P) and one site for ADP and PEP.

Compulsory Order Mechanism

- In multi reactant enzyme catalyzed reactions, if the reactants must bind to the enzyme active site in a specific order the reaction type is called a compulsory order reaction or compulsory order mechanism.