

## Chap 7: Boundary Layer

If the movement of fluid is not affected by its viscosity, it could be treated as the flow of ideal fluid, therefore its analysis would be easier. The flow around a solid, however, cannot be treated in such a manner because of viscous friction. Nevertheless, only the very thin region near the wall is affected by this friction. Prandtl identified this phenomenon and had the idea to divide the flow into two regions. They are:

1. the region near the wall where the movement of flow is controlled by the frictional resistance.
2. the other region outside the above not affected by the friction and,

### Development of boundary layer

The distance from the body surface when the velocity reaches 99% of the velocity of the main flow is defined as the boundary layer thickness  $\delta$ . The boundary layer continuously thickens with the distance over which it flows. This process is visualized as shown in the below Figure.

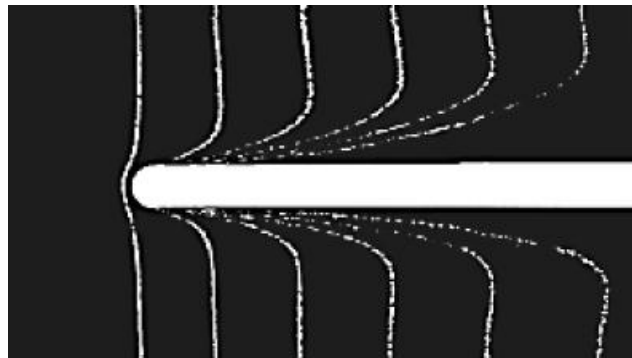

However, viscous flow boundary layer characteristics for external flows are significantly different as shown below for flow over a flat plate:

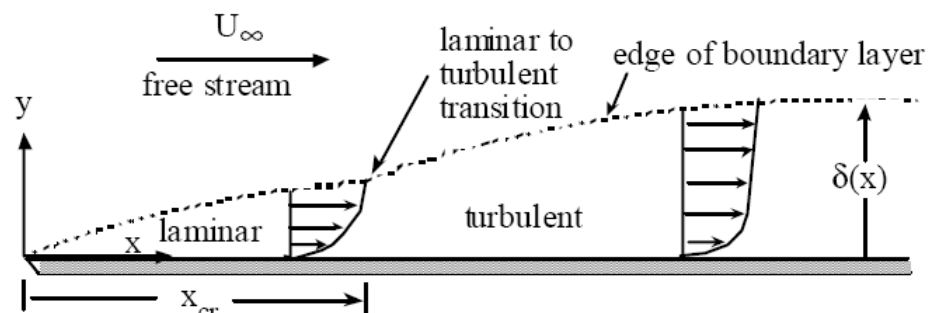

The most important fluid flow parameter is the local Reynolds number defined as :

$$Re_x = \frac{\rho U_\infty x}{\mu} = \frac{U_\infty x}{\nu}$$

Transition from laminar to turbulent flow typically occurs at the local transition Reynolds number which for flat plate flows can be in the range of

$$500,000 \leq Re_{cr} \leq 3,000,000$$

When the flow distribution and the drag are considered, it is useful to use the following displacement thickness  $\delta^*$  and momentum thickness  $\theta$  instead of  $\delta$ .

### Displacement thickness $\delta^*$

$\delta^*$  = distance the solid surface would have to be displaced to maintain the same mass flow rate as for non-viscous flow.

$$U\delta^* = \int_0^{\infty} (U - u)dy$$

$$\delta^* = \int_0^{\delta} \left(1 - \frac{u}{U_{\infty}}\right) dy$$

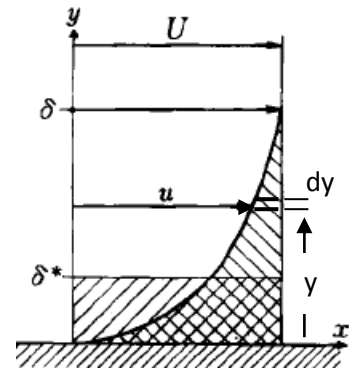

Therefore, with an expression for the local velocity profile we can obtain  $\delta^* = f(\delta)$

#### Example:

Given:  $\frac{u}{U_{\infty}} = 2\left(\frac{y}{\delta}\right) - \left(\frac{y}{\delta}\right)^2$  determine an expression for  $\delta^* = f(\delta)$

Note that for this assumed form for the velocity profile:

1. At  $y = 0$ ,  $u = 0$  correct for no slip condition
2. At  $y = \delta$ ,  $u = U_{\infty}$  correct for edge of boundary layer

let  $\eta = y/\delta$ , at  $y = 0$ ,  $\eta = 0$ ; at  $y = \delta$ ,  $\eta = 1$ ;  $dy = \delta d\eta$

Therefore:  $\frac{u}{U_{\infty}} = 2\eta - \eta^2$

Substituting:  $\delta^* = \int_0^1 (1 - 2\eta + \eta^2)\delta d\eta = \delta \left\{ \eta - \frac{2\eta^2}{2} + \frac{\eta^3}{3} \right\}_0^1$

which yields  $\delta^* = \frac{1}{3}\delta$ . This closely approximates flow for a flat plate.

### Momentum Thickness $\theta$ :

The concept is similar to that of displacement thickness in that  $\theta$  is related to the loss of momentum due to viscous effects in the boundary layer.

$$\rho U^2 \theta = \rho \int_0^{\infty} u(U - u)dy$$

$$\theta = \int_0^{\delta} \frac{u}{U_{\infty}} \left(1 - \frac{u}{U_{\infty}}\right) dy$$

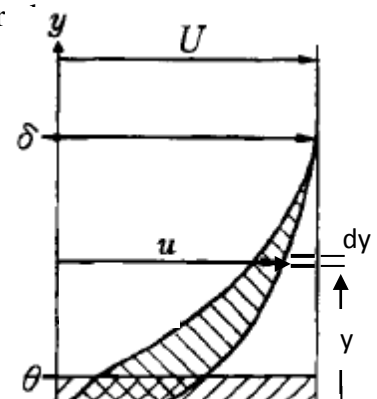

The momentum thickness  $\theta$  equates the momentum decrease per unit time due to the existence of the body wall to the momentum per unit time which passes at velocity  $U$  through a height of thickness  $\theta$ . The momentum decrease is equivalent to the force acting on the body according to the law of momentum conservation. Therefore the drag on a body generated by the viscosity can be obtained by using the momentum thickness

### Drag on a flat plate

Consider the viscous flow regions shown in the adjacent figure. Define a control volume as shown and integrate around the control volume to obtain the net change in momentum for the control volume.

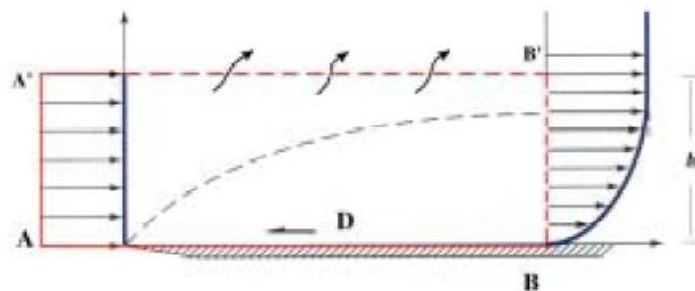

If  $D =$  drag force on the plate due to viscous flow, we can write

$$- D = \Sigma (\text{momentum leaving c.v.}) - \Sigma (\text{momentum entering c.v.})$$

The drag force on the plate is given by the following momentum integral across the exit plane

$$D(x) = \rho b \int_0^{\delta(x)} u(U - u) dy \quad , \text{ where } b \text{ is the plate width into the paper .}$$

The above Equation was derived in 1921 by Kármán , who wrote it in the convenient form of the **momentum thickness**  $\theta$  :

$$D(x) = \rho b U^2 \theta \quad \theta = \int_0^{\delta} \frac{u}{U} \left( 1 - \frac{u}{U} \right) dy$$

Momentum thickness is thus a measure of total plate drag. Kármán then noted that the drag also equals the integrated wall shear stress along the plate

$$D(x) = b \int_0^x \tau_w(x) dx$$

$$\frac{dD}{dx} = b\tau_w \quad (1)$$

$$\frac{dD}{dx} = \rho b U^2 \frac{d\theta}{dx}$$

By comparing the above equations, Kármán arrived at what is now called **the momentum integral relation** for flat-plate boundary-layer flow

$$\tau_w = \rho U^2 \frac{d\theta}{dx} \quad \dots\dots\dots (1)$$

It is valid for either laminar or turbulent flat-plate flow

**Laminar flow**

To get a numerical result for laminar flow, Kármán assumed that the velocity profiles had an approximately parabolic shape

$$u(x, y) \approx U \left( \frac{2y}{\delta} - \frac{y^2}{\delta^2} \right) \quad 0 \leq y \leq \delta(x)$$

which makes it possible to estimate both momentum thickness and wall shear

$$\theta = \int_0^\delta \left( \frac{2y}{\delta} - \frac{y^2}{\delta^2} \right) \left( 1 - \frac{2y}{\delta} + \frac{y^2}{\delta^2} \right) dy \approx \frac{2}{15} \delta$$

$$\tau_w = \mu \left. \frac{\partial u}{\partial y} \right|_{y=0} \approx \frac{2\mu U}{\delta} \quad \dots\dots\dots (2)$$

By substituting (2) into (1) and integrating from 0 to x, assuming that  $\delta = 0$  at  $x = 0$ , the leading edge

$$\frac{\delta}{x} \approx 5.5 \left( \frac{\nu}{Ux} \right)^{1/2} = \frac{5.5}{\text{Re}_x^{1/2}} \quad \dots\dots\dots (3)$$

This is the desired thickness estimate. We define the boundary layer thickness  $\delta$  as the locus of points where the velocity  $u$  parallel to the plate reaches 99% of the external velocity so that the above value of  $\delta$  is represented about 10% higher than the known exact solution for laminar flow, the accepted formulas for flat-plate flow

$$\frac{\delta}{x} \approx \frac{5.0}{\text{Re}_x^{1/2}} \quad \text{Blasius (1908)}$$

By combining this Equation and (2), we also obtain a shear-stress estimate along the plate

$$c_f = \frac{2\tau_w}{\rho U^2} \approx \left( \frac{8}{15} \right)^{1/2} = \frac{0.73}{\text{Re}_x^{1/2}} \quad \dots\dots\dots (4)$$

The dimensionless quantity  $c_f$ , called the *skin-friction coefficient*, is analogous to the friction factor  $f$  in ducts. Again this estimate, in spite of the crudeness of the profile above assumption is only 10% higher than of exact solution. So the known exact laminar-plate-flow solution of  $c_f$  as the following :

$$c_f = \frac{0.664}{\text{Re}_x^{1/2}}$$

With the profile known, Blasius, of course, could also compute the wall shear and displacement thickness

$$\delta^* \approx \frac{1}{3} \delta \quad \frac{\delta^*}{x} \approx \frac{1.83}{\text{Re}_x^{1/2}} \quad \dots\dots\dots (5)$$

These estimates are only 6 percent away from the exact solutions for laminar flat-plate  $\frac{\delta^*}{x} = \frac{1.721}{\text{Re}_x^{1/2}}$  ( Exact solution of the displacement thickness )

Notice how close these are to our integral estimates, Eqs. (3), (4), and (5). we have

$$\tau_w(x) = \frac{0.332\rho^{1/2}\mu^{1/2}U^{1.5}}{x^{1/2}}$$

$$\tau_w(x) = \frac{0.332\rho U^2}{\text{Re}_L^{1/2}}$$

we compute the total drag force

$$D(x) = b \int_0^x \tau_w(x) dx = 0.664b\rho^{1/2}\mu^{1/2}U^{1.5}x^{1/2} \quad \text{-----} (1)$$

The drag increases only as the square root of the plate length. The nondimensional *drag coefficient* is defined as

$$C_D = \frac{2D(L)}{\rho U^2 b L} = \frac{1.328}{\text{Re}_L^{1/2}}$$

Thus the drag on one side in the airflow is

$$D = C_{D/2}\rho U^2 b L$$

**EXAMPLE**

A sharp flat plate with  $L= 1$  m and  $b= 3$  m is immersed parallel to a stream of velocity 2 m/s.

Find the drag on one side of the plate, and at the trailing edge find the thicknesses  $\delta$ ,  $\delta^*$ , and  $\theta$  for (a) air,  $\rho = 1.23 \text{ kg/m}^3$  and  $\nu = 1.46 \times 10^{-5} \text{ m}^2/\text{s}$ , and (b) water,  $\rho = 1000 \text{ kg/m}^3$  and  $\nu = 1.02 \times 10^{-6} \text{ m}^2/\text{s}$

**Part (a)**

The airflow Reynolds number is

$$\frac{VL}{\nu} = \frac{(2.0 \text{ m/s})(1.0 \text{ m})}{1.46 \times 10^{-5} \text{ m}^2/\text{s}} = 137,000$$

Since this is less than  $3 \times 10^6$ , the boundary layer is laminar. The drag coefficient is :

$$C_D = \frac{1.328}{(137,000)^{1/2}} = 0.00359$$

Thus the drag on one side in the airflow is

$$D = C_D \frac{1}{2} \rho U^2 b L = 0.00359 \left(\frac{1}{2}\right) (1.23) (2.0)^2 (3.0) (1.0) = 0.0265 \text{ N}$$

We find the other two thicknesses simply by ratios:

$$\delta^* = \frac{1.721}{5.0} \delta = 4.65 \text{ mm} \quad \theta = \frac{\delta^*}{2.59} = 1.79 \text{ mm}$$

**Part (b)**

The water Reynolds number is

$$\text{Re}_L = \frac{2.0(1.0)}{1.02 \times 10^{-6}} = 1.96 \times 10^6$$

This is rather close to the critical value of  $3 \times 10^6$ , so that a rough surface or noisy free stream might trigger transition to turbulence; but let us assume that the flow is laminar. The water drag coefficient is

$$C_D = \frac{1.328}{(1.96 \times 10^6)^{1/2}} = 0.000949$$

$$D = 0.000949 \left(\frac{1}{2}\right) (1000) (2.0)^2 (3.0) (1.0) = 5.70 \text{ N}$$

The drag is 215 times more for water in spite of the higher Reynolds number and lower drag coefficient because water is 57 times more viscous and 813 times denser than air. From Eq.(1), in laminar flow, it should have  $(57)^{1/2} (813)^{1/2} = 7.53 (28.5) = 215$  times more drag. The boundary-layer thickness is given by :

$$\frac{\delta}{L} = \frac{5.0}{(1.96 \times 10^6)^{1/2}} = 0.00357$$

$$\delta = 0.00357(1000 \text{ mm}) = 3.57 \text{ mm}$$

$$\delta^* = \frac{1.721}{5.0} \delta = 1.23 \text{ mm} \quad \theta = \frac{\delta^*}{2.59} = 0.48 \text{ mm}$$

The water layer is 3.8 times thinner than the air layer, which reflects the square root of the 14.3 ratio of air to water kinematic viscosity.

### Turbulent flow

A Prandtl, is pointed out that the turbulent profiles can be approximated by a one-seventh-power law

$$\left(\frac{u}{U}\right)_{\text{turb}} \approx \left(\frac{y}{\delta}\right)^{1/7}$$

There is no exact theory for turbulent flat-plate flow, the most widely accepted result is simply an integral analysis similar to our study of the laminar-profile approximation. We begin with the same equation, which is valid for laminar or turbulent flow:

$$\tau_w(x) = \rho U^2 \frac{d\theta}{dx}$$

With this simple approximation, the momentum thickness can easily be evaluated:

$$\theta \approx \int_0^{\delta} \left(\frac{y}{\delta}\right)^{1/7} \left[1 - \left(\frac{y}{\delta}\right)^{1/7}\right] dy = \frac{7}{72} \delta$$

$$c_f = \frac{2\tau_w}{\rho U^2}$$

From the definition of  $c_f$ , it can be rewritten as:

$$c_f = 2 \frac{d\theta}{dx}$$

A Prandtl is simplified the friction law as the following a suggestion of power-law approximation

$$c_f = 0.02 \text{ Re}_{\delta}^{-1/6} = 2 \frac{d}{dx} \left(\frac{7}{72} \delta\right)$$

$$\text{Re}_\delta^{-1/6} = 9.72 \frac{d\delta}{dx} = 9.72 \frac{d(\text{Re}\delta)}{d(\text{Re}_x)}$$

Separate the variables and integrate, assuming  $\delta = 0$  at  $x = 0$  :

$$\text{Re}_\delta \approx 0.16 \text{Re}_x^{6/7} \quad \text{or} \quad \frac{\delta}{x} \approx \frac{0.16}{\text{Re}_x^{1/7}}$$

we obtain the friction variation

$$c_f \approx \frac{0.027}{\text{Re}_x^{1/7}}$$

Writing this out in dimensional form, we have

$$\tau_{w,\text{turb}} \approx \frac{0.0135 \mu^{1/7} \rho^{6/7} U^{13/7}}{x^{1/7}}$$

Turbulent plate friction drops slowly with  $x$ , increases nearly as  $\rho$  and  $U^2$ , and is rather insensitive to viscosity. We can evaluate the drag coefficient

$$C_D = \frac{0.031}{\text{Re}_L^{1/7}}$$

Then the drag on both sides of the plate :

$$D = 2C_D(\frac{1}{2}\rho U^2)bL$$

### EXAMPLE

A hydrofoil 0.366 m long and 1.82 m wide is placed in a water flow of 12.9 m/s, with  $\rho = 1025.3 \text{ kg/m}^3$  and  $\nu = 1.02 \times 10^{-6} \text{ m}^2/\text{s}$ . (a) Estimate the boundary-layer thickness at the end of the plate. Estimate the friction drag for (b) turbulent smooth-wall flow from the leading edge, (c) laminar turbulent flow with  $\text{Re}_{\text{tren}} =$

$$\text{Re}_L = \frac{UL}{\nu} = 4.36 \times 10^6$$

Thus the trailing-edge flow is certainly turbulent. The maximum boundary-layer thickness would occur for turbulent flow starting at the leading edge.

$$\frac{\delta}{x} \approx \frac{0.16}{\text{Re}_x^{1/7}} \quad \delta = 0.0065 \text{ m}$$

For fully turbulent smooth-wall flow, the drag coefficient on one side of the plate is,

$$C_D = \frac{0.031}{\text{Re}_L^{1/7}} \quad C_D = \frac{0.031}{(4.36 \times 10^6)^{1/7}} = 0.00349$$



Then the drag on both sides of the foil is approximately

$$D = 2C_D\left(\frac{1}{2}\rho U^2\right)bL \quad D = 355.84 \text{ N}$$

**Part (c)** With a laminar leading edge and  $Re_{trans} = 5 \times 10^5$ ,

$$C_D = 0.00349 - \frac{1440}{4.36 \times 10^6} = 0.00316$$

The drag can be recomputed for this

lower drag coefficient:

$$D = 2C_D\left(\frac{1}{2}\rho U^2\right)bL \quad D = 320.25 \text{ N}$$

**Example:** Consider the smooth square 10 by 10 cm duct in below Figure. The fluid is air at 20°C and 1 atm, flowing at  $V_{avr} = 24$  m/s. It is desired to increase the pressure drop over the 1-m length by adding sharp 8-mm-long flat plates across the duct, as shown. (a) Estimate the pressure drop if there are no plates. (b) Estimate how many plates are needed to generate an additional

$$Re_{Dh} = \frac{VD_h}{\nu} = \frac{(24 \text{ m/s})(0.1 \text{ m})}{0.000015 \text{ m}^2/\text{s}} = 160000 \text{ (turbulent)}$$

$$f_{smooth} = 0.0163$$

$$\Delta p_{Moody} = f \frac{L}{D_h} \frac{\rho V^2}{2} = 56 \text{ Pa} \quad \text{Ans. (a)}$$

$$Re_L = \frac{(24)(0.008)}{0.000015} = 12800, \quad C_D = \frac{1.328}{\sqrt{12800}} = 0.0117$$

$$F = C_D \frac{\rho}{2} V^2 b L (2 \text{ sides}) = (0.0117) \frac{1.2}{2} (24)^2 (0.1)(0.008)(2) = 0.00649 \text{ N}$$

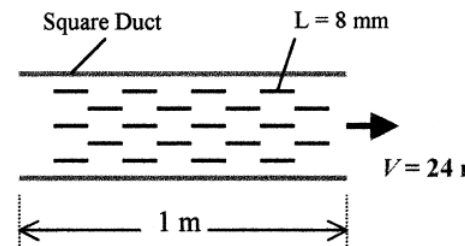

(b) To estimate the plate-induced pressure drop, first calculate the drag on one plate:

$$\Delta p_{extra} = 100 \text{ Pa} = \frac{FN_{plates}}{A_{duct}} = \frac{(0.00649 \text{ N})N_{plates}}{(0.1 \text{ m})^2}, \quad \text{or: } N_{plates} \approx 154 \text{ Ans. (b)}$$

Since the duct walls must support these plates, the effect is an additional pressure drop:

### Boundary Layer

**Q1:** For flow at 20 m/s past a thin flat plate, estimate the distances  $x$  from the leading edge at which the boundary layer thickness will be either 1 mm or 10 cm, for (a) air; and (b) water

For air, take  $\rho = 1.2 \text{ kg/m}^3$  and  $\mu = 1.8 \times 10^{-5} \text{ kg/m.s}$  and for water, take  $\rho = 998 \text{ kg/m}^3$  and

$\mu = 0.001 \text{ kg/m.s}$ .

$m, 9.5 \text{ m}$

Ans : a) 0.0533 m , 6.06 m b) 0.0442

**Q<sub>2</sub>** : Air, equivalent to a Standard Altitude of 4000 m, flows at 201 m/s past a wing which has a thickness of 18 cm, a chord length of 1.5 m, and a wingspan of 12 m. What is the appropriate value of the Reynolds number for correlating the lift and drag of this wing ? Take  $\rho = 0.819 \text{ kg/m}^3$ ,  $\mu = 1.66 \times 10^{-5} \text{ kg/m.s}$ .

**Ans** :  $1.5 \times 10^7$

**Q<sub>3</sub>**: A smooth ceramic sphere (s.g = 2.6) is immersed in a flow of water at of velocity 25 cm/s. What is the sphere diameter if it is encountering (a) creeping motion,  $Re_d = 1$ ; or (b) transition to turbulence,  $Re_d = 250,000$ ? For water, take  $\rho = 998 \text{ kg/m}^3$  and  $\mu = 0.001 \text{ kg/m.s}$ .

**Ans**:  $4 \times 10^{-6} \text{ m}$  , 1

**Q<sub>4</sub>**: Air,  $\rho = 1.2 \text{ kg/m}^3$  and  $\mu = 1.8 \times 10^{-5} \text{ kg/m.s}$ , flows at 10 m/s past a flat plate. At the trailing edge of the plate, the following velocity profile data are measured:

|                                      |   |       |       |       |       |      |      |      |
|--------------------------------------|---|-------|-------|-------|-------|------|------|------|
| y, mm:                               | 0 | 0.5   | 1.0   | 2.0   | 3.0   | 4.0  | 5.0  | 6.0  |
| u, m/s:                              | 0 | 1.75  | 3.47  | 6.58  | 8.70  | 9.68 | 10.0 | 10.0 |
| $u(U - u)$ , $\text{m}^2/\text{s}$ : | 0 | 14.44 | 22.66 | 22.50 | 11.31 | 3.10 | 0.0  | 0.0  |

If the upper surface has an area of  $0.6 \text{ m}^2$ , estimate, using momentum concepts, the friction drag, in newtons, on the upper surface. Take the relation of  $F = \rho b \int u(U - u)dy$ . friction drag as

**Ans**: 0.073 b

**Q<sub>5</sub>** : Given the parabolic profile with the more accurate sinusoidal profile and repeat the flat-plate momentum analysis :

$$\frac{u}{U} \approx \sin\left(\frac{\pi y}{2\delta}\right)$$

Compute momentum-integral estimates of  $C_f$ ,  $\delta/x$ ,  $\delta^*/x$ , and  $\delta^*/\theta$

$$\frac{\delta}{x} \approx \frac{4.80}{\sqrt{Re_x}}; \quad C_f = \frac{\theta}{x} \approx \frac{0.655}{\sqrt{Re_x}}; \quad \frac{\delta^*}{x} \approx \frac{1.743}{\sqrt{Re_x}}; \quad H = \frac{\delta^*}{\theta} \approx 2.66 \quad \text{Ans.}$$

**Q<sub>6</sub>** : Air flows at 2 m/s past a sharp flat plate. Assuming that the Kármán parabolic-profile analysis, is accurate :

$$u = U \left( \frac{2y}{\delta} - \frac{y^2}{\delta^2} \right)$$

and, take  $\rho = 1.2 \text{ kg/m}^3$  and  $\mu = 1.8 \times 10^{-5} \text{ kg/m.s}$ . Estimate: (a) the local velocity  $u$  ; and (b) the local shear stress at the position  $(x, y) = (50 \text{ cm}, 5 \text{ mm})$ .

Ans : 1.44 m/s ,

0.036 N/m<sup>2</sup>

**Q<sub>7</sub>** : Helium at 20°C and low pressure flows past a thin flat plate 1 m long and 2 m wide. It is desired that the total friction drag of the plate be 0.5 N. What is the appropriate absolute pressure of the helium if  $U = 35$  m/s?

For helium at 20°C, take  $R = 2077$  J/kg·K and  $\mu = 1.97E-5$  kg/m·s.

Ans :  
25500 N/m<sup>2</sup>

**Q<sub>8</sub>**: Suppose you buy a 4 × 2.44 m sheet of plywood and put it on your roof rack, as in the Figure. You drive home at 15.6 m/s. (a) If the board is perfectly aligned with the airflow, how thick is the boundary layer at the end? (b) Estimate the drag if the flow remains laminar. (c) Estimate the drag for (smooth) turbulent flow.

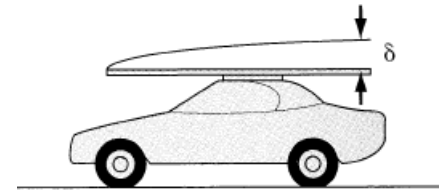

For air take  $\rho = 1.2$  kg/m<sup>3</sup> and  $\mu = 1.8E-5$  kg/m·s

Ans: a) 0.00765 m , 0.047 m b) 0.73 N

c) 3.3 N

**Q<sub>9</sub>**: Devise a scheme for determining the boundary-layer thickness more accurately when the flow is laminar up to a point  $Re_{x,crit}$  and turbulent thereafter. Apply this scheme to computation of the boundary-layer thickness at  $x = 1.5$  m in 40 m/s flow of air at 20°C and 1 atm past take  $\rho = 1.2$  kg/m<sup>3</sup> and  $\mu = 1.8E-5$  kg/m·s a flat plate. Assume  $Re_{x,crit} = 1.2E6$ .

Ans: 0.0213 m

**Q<sub>10</sub>**: Air at 20°C and 1 atm enters  $L_0 = 40$ -cm square duct as in the Figure. Using the displacement thickness estimate (a) the mean velocity and (b) the mean pressure in the core of the flow at the position  $x = 3$  m. (c) What is the average gradient,  $\Delta p/x$  in Pa/m, in this section?

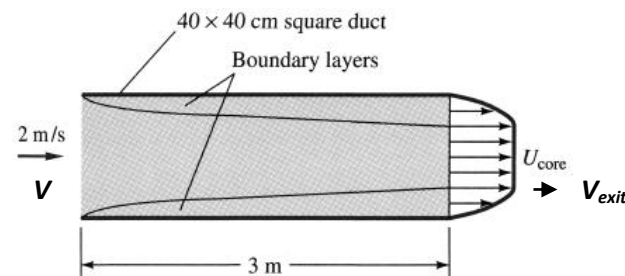

take  $\rho = 1.2$  kg/m<sup>3</sup> and  $\mu = 1.8E-5$  kg/m·s.

help : use  $V_{exit} = V \left( \frac{L_0}{L_0 - 2\delta^*} \right)^2$

Ans : 2.175 m/s , 0.56 N/m<sup>2</sup> , -0.15 pa/m

**Q<sub>11</sub>**: A thin smooth disk of diameter  $D$  is Immersed parallel to a uniform stream of velocity  $U$ . Assuming laminar flow and using flat-plate theory as a guide, develop an approximate formula for the coefficient of the drag of the disk.

Ans:  $C_D = \frac{F}{(\rho/2)U^2\pi R^2} \approx \frac{2.96}{\sqrt{\rho UD/\mu}}$

**Q<sub>12</sub>**: In the flow of air at 20°C and 1 atm past a flat plate in the Figure, the wall shear is to be determined at position  $x$  by a floating element (a small area connected to a strain-gage force measurement). At  $x = 2$  m, the element indicates a shear stress of 2.1 N. Assuming turbulent flow from the leading edge, estimate (a) the stream velocity

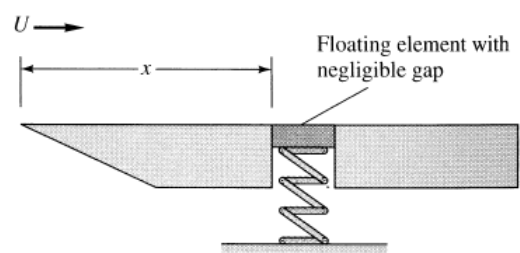

$U$ , (b) the boundary layer thickness  $\delta$  at the Element, and (c) the boundary-layer velocity  $u$ , in m/s, at 5 cm above the element.

take  $\rho = 1.2 \text{ kg/m}^3$  and  $\mu = 1.8\text{E-}5 \text{ kg/m}\cdot\text{s}$ .