

why do we need to assign IP addresses to routers? The answer is that in some protocols a router may act as a sender or receiver of a datagram. For example, in routing protocols, a router is a sender or receiver of a message. The communications in these protocols are between routers.

- ❑ Why do we need more than one IP address in a router, one for each interface? The answer is that an interface is a connection of a router to a link. We will see that an IP address defines a point in the Internet at which a device is connected. A router with n interfaces is connected to the Internet at n points. This is the situation of a house at the corner of a street with two gates; each gate has the address related to the corresponding street.
- ❑ How are the source and destination IP addresses in a packet determined? The answer is that the host should know its own IP address, which becomes the source IP address in the packet. As we will discuss in Chapter 26, the application layer uses the services of DNS to find the destination address of the packet and passes it to the network layer to be inserted in the packet.
- ❑ How are the source and destination link-layer addresses determined for each link? Again, each hop (router or host) should know its own link-layer address, as we discuss later in the chapter. The destination link-layer address is determined by using the Address Resolution Protocol, which we discuss shortly.
- ❑ What is the size of link-layer addresses? The answer is that it depends on the protocol used by the link. Although we have only one IP protocol for the whole Internet, we may be using different data-link protocols in different links. This means that we can define the size of the address when we discuss different link-layer protocols.

9.2.1 Three Types of addresses

Some link-layer protocols define three types of addresses: unicast, multicast, and broadcast.

Unicast Address

Each host or each interface of a router is assigned a unicast address. Unicasting means one-to-one communication. A frame with a unicast address destination is destined only for one entity in the link.

Example 9.1

As we will see in Chapter 13, the unicast link-layer addresses in the most common LAN, Ethernet, are 48 bits (six bytes) that are presented as 12 hexadecimal digits separated by colons; for example, the following is a link-layer address of a computer.

A3:34:45:11:92:F1

Multicast Address

Some link-layer protocols define multicast addresses. Multicasting means one-to-many communication. However, the jurisdiction is local (inside the link).

Example 9.2

As we will see in Chapter 13, the multicast link-layer addresses in the most common LAN, Ethernet, are 48 bits (six bytes) that are presented as 12 hexadecimal digits separated by colons. The second digit, however, needs to be an even number in hexadecimal. The following shows a multicast address:

A2:34:45:11:92:F1

Broadcast Address

Some link-layer protocols define a broadcast address. Broadcasting means one-to-all communication. A frame with a destination broadcast address is sent to all entities in the link.

Example 9.3

As we will see in Chapter 13, the broadcast link-layer addresses in the most common LAN, Ethernet, are 48 bits, all 1s, that are presented as 12 hexadecimal digits separated by colons. The following shows a broadcast address:

FF:FF:FF:FF:FF:FF

9.2.2 Address Resolution Protocol (ARP)

Anytime a node has an IP datagram to send to another node in a link, it has the IP address of the receiving node. The source host knows the IP address of the default router. Each router except the last one in the path gets the IP address of the next router by using its forwarding table. The last router knows the IP address of the destination host. However, the IP address of the next node is not helpful in moving a frame through a link; we need the link-layer address of the next node. This is the time when the **Address Resolution Protocol (ARP)** becomes helpful. The ARP protocol is one of the auxiliary protocols defined in the network layer, as shown in Figure 9.6. It belongs to the network layer, but we discuss it in this chapter because it maps an IP address to a logical-link address. ARP accepts an IP address from the IP protocol, maps the address to the corresponding link-layer address, and passes it to the data-link layer.

Figure 9.6 Position of ARP in TCP/IP protocol suite

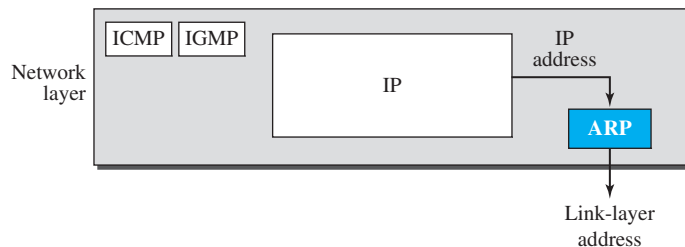

Anytime a host or a router needs to find the link-layer address of another host or router in its network, it sends an ARP request packet. The packet includes the link-layer and IP addresses of the sender and the IP address of the receiver. Because the sender does not know the link-layer address of the receiver, the query is broadcast over the link using the link-layer broadcast address, which we discuss for each protocol later (see Figure 9.7).

Figure 9.7 ARP operation

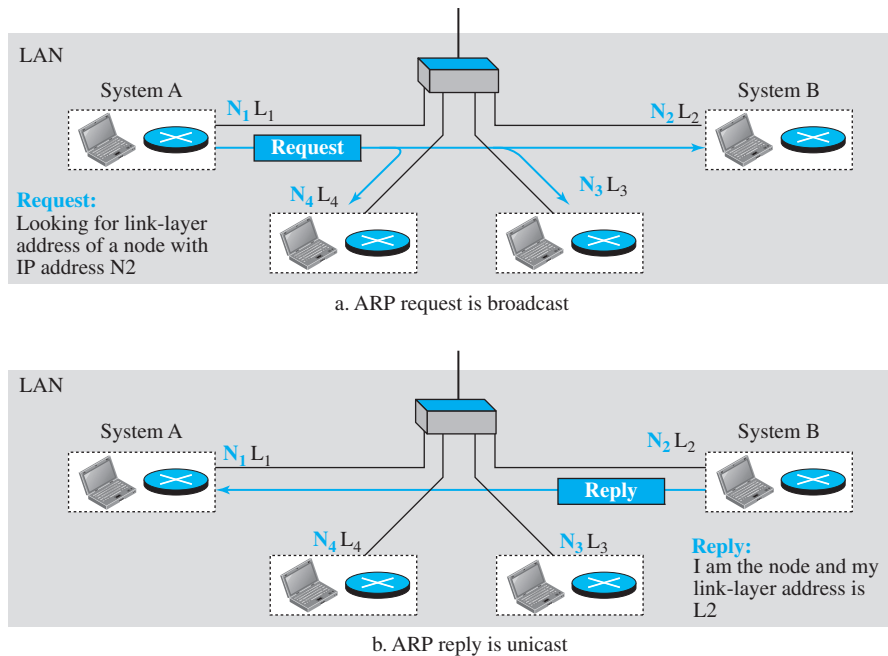

Every host or router on the network receives and processes the ARP request packet, but only the intended recipient recognizes its IP address and sends back an ARP response packet. The response packet contains the recipient's IP and link-layer addresses. The packet is unicast directly to the node that sent the request packet.

In Figure 9.7a, the system on the left (A) has a packet that needs to be delivered to another system (B) with IP address N_2 . System A needs to pass the packet to its data-link layer for the actual delivery, but it does not know the physical address of the recipient. It uses the services of ARP by asking the ARP protocol to send a broadcast ARP request packet to ask for the physical address of a system with an IP address of N_2 .

This packet is received by every system on the physical network, but only system B will answer it, as shown in Figure 9.7b. System B sends an ARP reply packet that includes its physical address. Now system A can send all the packets it has for this destination using the physical address it received.

Caching

A question that is often asked is this: If system A can broadcast a frame to find the link-layer address of system B, why can't system A send the datagram for system B using a broadcast frame? In other words, instead of sending one broadcast frame (ARP request), one unicast frame (ARP response), and another unicast frame (for sending the datagram), system A can encapsulate the datagram and send it to the network. System B receives it and keep it; other systems discard it.

To answer the question, we need to think about the efficiency. It is probable that system A has more than one datagram to send to system B in a short period of time. For example, if system B is supposed to receive a long e-mail or a long file, the data do not fit in one datagram.

Let us assume that there are 20 systems connected to the network (link): system A, system B, and 18 other systems. We also assume that system A has 10 datagrams to send to system B in one second.

- a. Without using ARP, system A needs to send 10 broadcast frames. Each of the 18 other systems need to receive the frames, decapsulate the frames, remove the datagram and pass it to their network-layer to find out the datagrams do not belong to them. This means processing and discarding 180 broadcast frames.
- b. Using ARP, system A needs to send only one broadcast frame. Each of the 18 other systems need to receive the frames, decapsulate the frames, remove the ARP message and pass the message to their ARP protocol to find that the frame must be discarded. This means processing and discarding only 18 (instead of 180) broadcast frames. After system B responds with its own data-link address, system A can store the link-layer address in its cache memory. The rest of the nine frames are only unicast. Since processing broadcast frames is expensive (time consuming), the first method is preferable.

Packet Format

Figure 9.8 shows the format of an ARP packet. The names of the fields are self-explanatory. The *hardware type* field defines the type of the link-layer protocol; Ethernet is given the type 1. The *protocol type* field defines the network-layer protocol: IPv4 protocol is $(0800)_{16}$. The source hardware and source protocol addresses are variable-length fields defining the link-layer and network-layer addresses of the sender. The destination hardware address and destination protocol address fields define the receiver link-layer and network-layer addresses. An ARP packet is encapsulated directly into a data-link frame. The frame needs to have a field to show that the payload belongs to the ARP and not to the network-layer datagram.

Example 9.4

A host with IP address **N1** and MAC address **L1** has a packet to send to another host with IP address **N2** and physical address **L2** (which is unknown to the first host). The two hosts are on the same network. Figure 9.9 shows the ARP request and response messages.

Figure 9.8 ARP packet

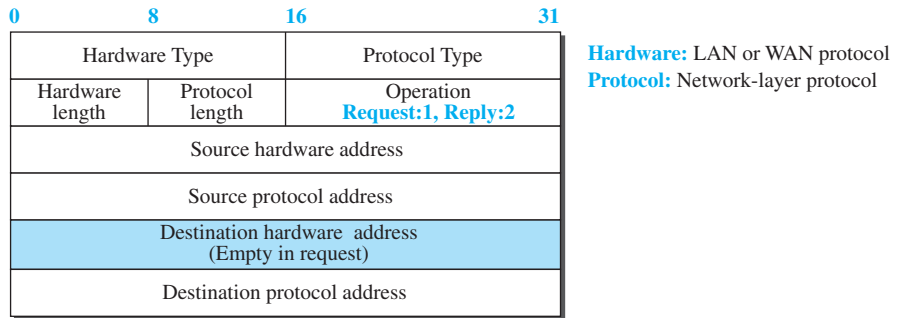
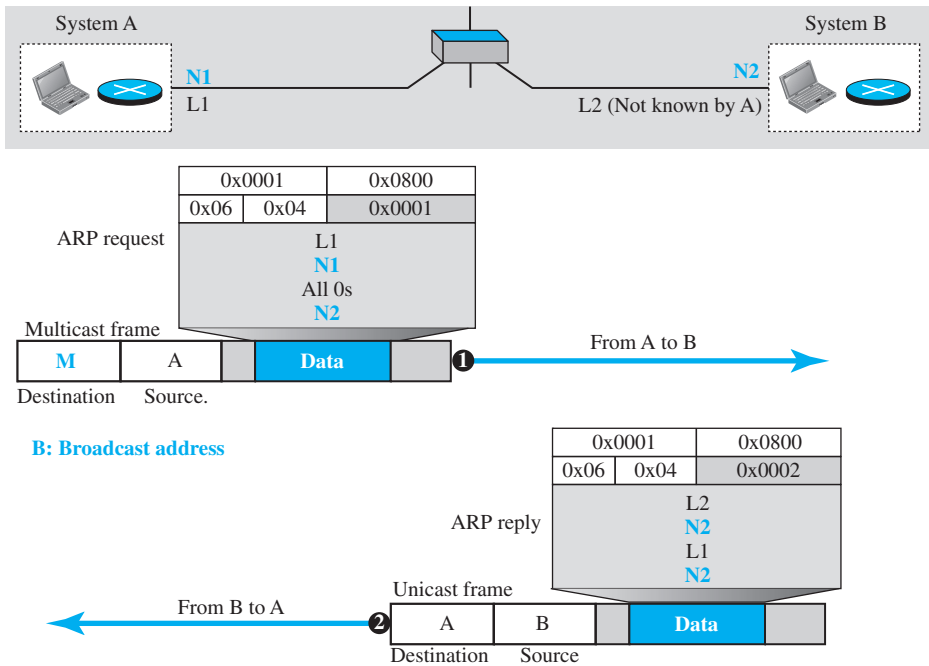

Figure 9.9 Example 9.4



9.2.3 An Example of Communication

To show how communication is done at the data-link layer and how link-layer addresses are found, let us go through a simple example. Assume Alice needs to send a datagram to Bob, who is three nodes away in the Internet. How Alice finds the network-layer address of Bob is what we discover in Chapter 26 when we discuss DNS. For the moment, assume that Alice knows the network-layer (IP) address of Bob. In other words, Alice's host is given the data to be sent, the IP address of Bob, and the

IP address of Alice's host (each host needs to know its IP address). Figure 9.10 shows the part of the internet for our example.

Figure 9.10 *The internet for our example*

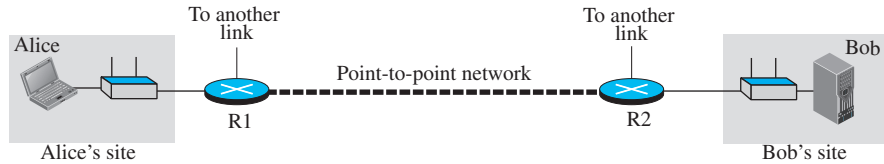

Activities at Alice's Site

We will use symbolic addresses to make the figures more readable. Figure 9.11 shows what happens at Alice's site.

Figure 9.11 *Flow of packets at Alice's computer*

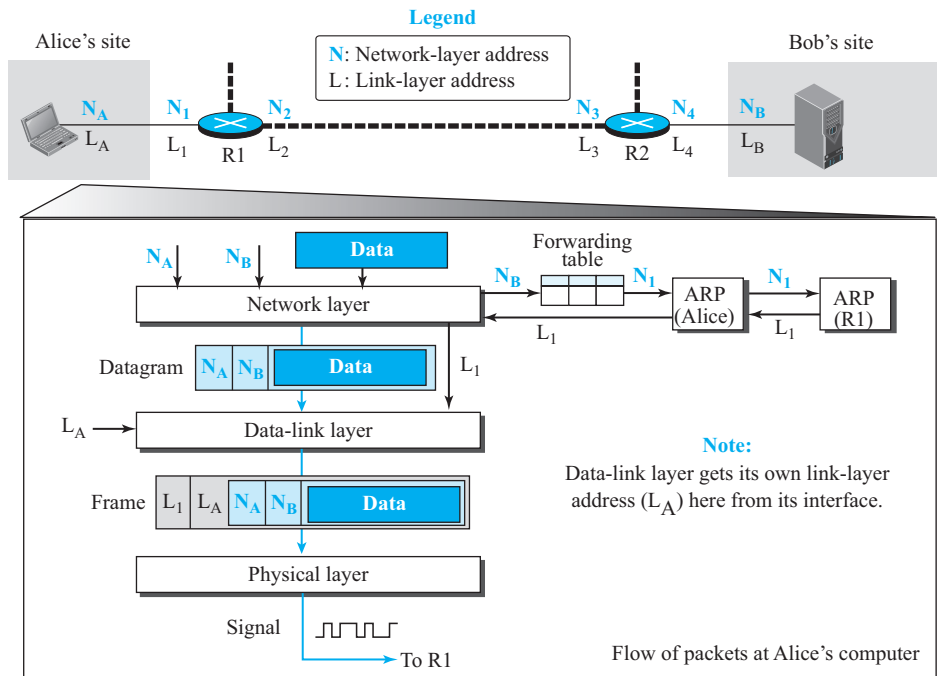

The network layer knows it's given N_A, N_B, and the packet, but it needs to find the link-layer address of the next node. The network layer consults its routing table and tries to find which router is next (the default router in this case) for the destination N_B. As we will discuss in Chapter 18, the routing table gives N₁, but the network layer

needs to find the link-layer address of router R1. It uses its ARP to find the link-layer address L_1 . The network layer can now pass the datagram with the link-layer address to the data-link layer.

The data-link layer knows its own link-layer address, L_A . It creates the frame and passes it to the physical layer, where the address is converted to signals and sent through the media.

Activities at Router R1

Now let us see what happens at Router R1. Router R1, as we know, has only three lower layers. The packet received needs to go up through these three layers and come down. Figure 9.12 shows the activities.

Figure 9.12 Flow of activities at router R1

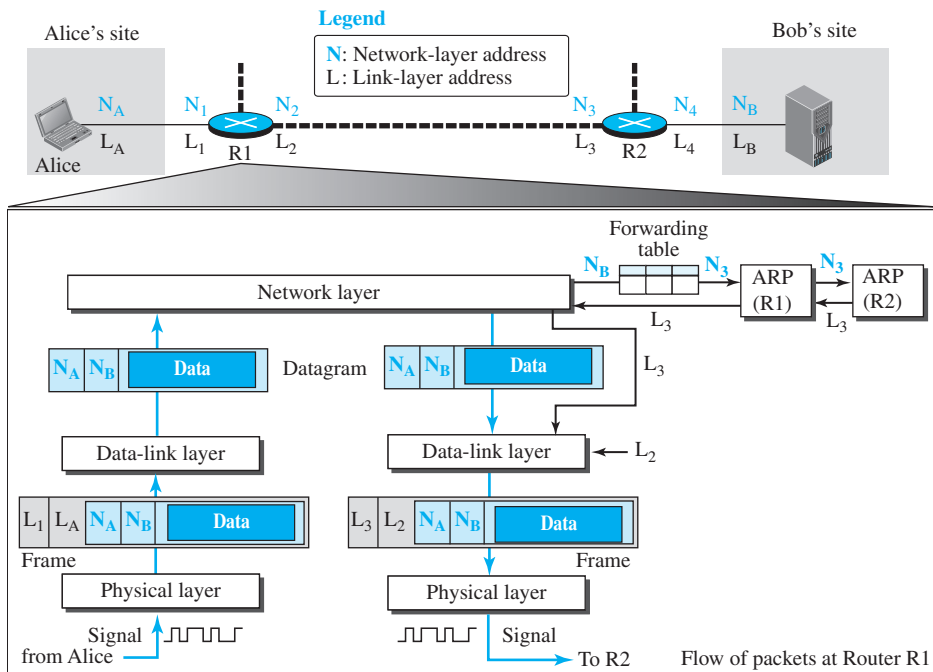

At arrival, the physical layer of the left link creates the frame and passes it to the data-link layer. The data-link layer decapsulates the datagram and passes it to the network layer. The network layer examines the network-layer address of the datagram and finds that the datagram needs to be delivered to the device with IP address N_B . The network layer consults its routing table to find out which is the next node (router) in the path to N_B . The forwarding table returns N_3 . The IP address of router R2 is in the same link with R1. The network layer now uses the ARP to find the link-layer address of this router, which comes up as L_3 . The network layer passes the datagram and L_3 to the data-link layer belonging to the link at the right side. The link layer

encapsulates the datagram, adds **L3** and **L2** (its own link-layer address), and passes the frame to the physical layer. The physical layer encodes the bits to signals and sends them through the medium to R2.

Activities at Router R2

Activities at router R2 are almost the same as in R1, as shown in Figure 9.13.

Figure 9.13 Activities at router R2.

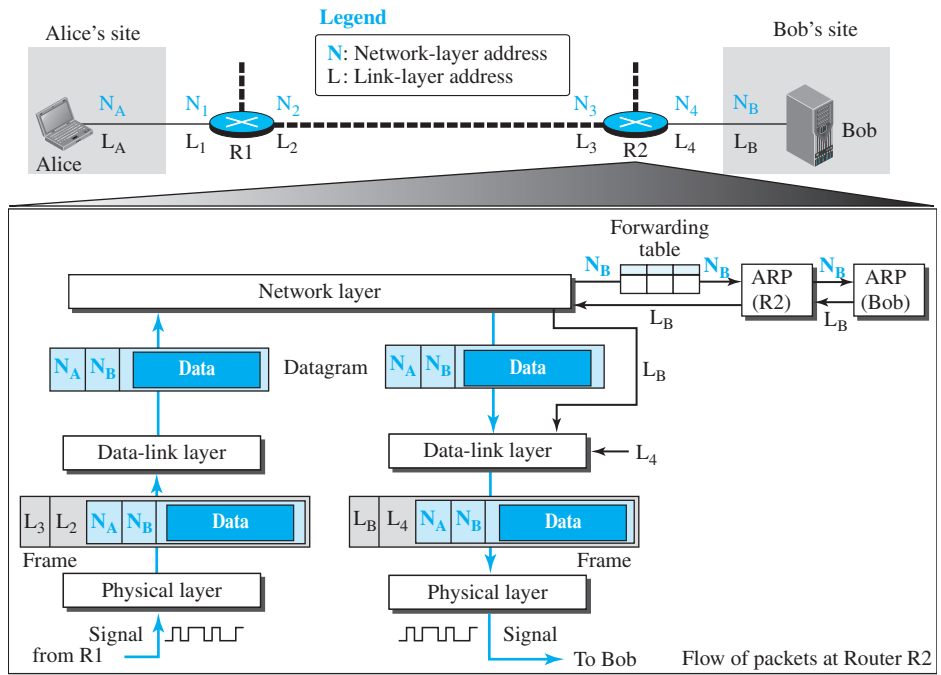

Activities at Bob's Site

Now let us see what happens at Bob's site. Figure 9.14 shows how the signals at Bob's site are changed to a message. At Bob's site there are no more addresses or mapping needed. The signal received from the link is changed to a frame. The frame is passed to the data-link layer, which decapsulates the datagram and passes it to the network layer. The network layer decapsulates the message and passes it to the transport layer.

Changes in Addresses

This example shows that the source and destination network-layer addresses, N_A and N_B , have not been changed during the whole journey. However, all four network-layer addresses of routers R1 and R2 (N_1, N_2, N_3 , and N_4) are needed to transfer a datagram from Alice's computer to Bob's computer.