

Surgical Instruments 101

An Introduction to
KMedic Certified
Instruments

by
Helmut Kapczynski

KMedic

It would not have been possible to write this manual without the help and input from many professionals in the field. I wish to thank all of them for their ideas and contributions. However, some individuals deserve to be mentioned by name as they have played an important role in creating the manual, especially Lourdes Figueroa, Colleen Neff, Jennifer Kapczynski, Elizabeth Ostrow, and Pamela Wiedenkeller.

Helmut Kapczynski
Northvale, New Jersey
1997

SURGICAL INSTRUMENTS 101: An Introduction to KMedic Certified Instruments. Copyright © 1997 by Helmut Kapczynski. All rights reserved. Printed in the United States of America. No part of this book may be used or reproduced in any manner whatsoever without written permission. For information contact: KMedic, Inc., 190 Veterans Drive, Northvale, New Jersey 07647.

KMedic
190 Veterans Drive
Northvale, NJ 07647

201.767.4002
800.955.0559
Fax: 201.768.0494
On-line: www.kmedic.com

Surgical Instruments 101:

An Introduction to KMedic Certified
Instruments

Table of Contents

Section A		Page #
1.	Introduction	A1
2.	KMedic's Mission	A3
3.	KMedic Certified	A3
4.	A Brief History of Surgical Instruments	A4
5.	The Selection of KMedic Instruments	A6
6.	The Manufacture of KMedic Instruments	A8
7.	The Materials Used in Manufacturing	A11
8.	KMedic Quality Assurance	A14
Section B		
9.	Classification by Usage	B1
10.	Basic Identification and Anatomy of Surgical Instruments: An Illustrated Guide	B2
11.	About KMedic Instruments: Major Product Groups	B14
12.	KMedic Instrument Care Instructions	B127
13.	Tips for Troubleshooting	B131
Section C		
14.	Glossary of Useful Terms	C1
15.	Selected Bibliography	C11
16.	Other Surgical Instrument Brand Names	C13
17.	Major Bone Anatomy	C15
18.	Index	C17

Section A

1. Introduction

For the individual not familiar with surgical instruments even a basic knowledge of the instruments and their uses may seem to be a challenging task. Most people have little experience with surgical instruments. The names are difficult, the differences may seem minuscule, and the uses for each instrument even more obscure. The beginner may easily feel intimidated without a proper introduction to the field.

Relax—we made it easy. This manual is designed precisely to offer that proper introduction. By the time you have reviewed this manual you will feel competent and ready to answer most questions likely to arise in regard to KMedic Certified Instruments.

This manual provides general information about instruments and familiarizes you with the concept of KMedic Certified Instruments. In addition to our main line of orthopedic instruments, we cover basic soft tissue instruments, since they are also frequently used by the orthopedists. To make your reading easier, the sections which explain our instruments in detail (“Basic Identification and Anatomy of Surgical Instruments,” and “About KMedic Instruments: Major Product Groups”) have been organized to match up with the order established in the KMedic Orthopedic Sourcebook. This manual is intended to offer a basic introduction, and should not be seen as a complete guide to orthopedic instrumentation.

The material is divided into three distinct sections and outlined in a detailed table of contents. Each of the sections serve as a building block. Broken down, the information becomes easily accessible, and by the end you can feel confident that you have a general knowledge of the main types of orthopedic instruments. You will understand the basic differences in the instrument variations, from the materials used to make them, to their functions. Within each group of instruments described, you will find a helpful outline of the basic properties of that group, including illustrations, to guide your reading of the more detailed sections. You will also learn about the process of instrument selection, production and quality assurance.

The manual also offers individuals with a basic knowledge of instruments further information about the instruments used in the field of orthopedics. You may read through the manual's distinct sections on an as needed basis. Once you have acquired the knowledge you need, the manual can also serve as a quick reference guide.

It is our intention to revise the manual periodically. We would appreciate any input you may have toward making it an even better resource, so that all KMedic employees, distributors and customers may benefit from it.

Helmut Kapczynski

Former President & CEO
KMedic

2. KMedic's Mission

KMedic aspires to be—and to be recognized by the medical profession as—the best orthopedic surgical instrument company. We will achieve this position by passionately pursuing excellence and by dedicating ourselves to improving the quality of life of everyone who interacts with us, particularly those individuals who rely on our products to heal and to cure.

3. KMedic Certified

KMedic is a company with a passion for excellence. As such, we are committed to "raising the bar" in every aspect of our business, from customer service to product development. With regard to instruments, this commitment takes the form of superior products that perform impeccably. In order to provide surgeons with the tools they need to operate with the utmost skill and confidence, we have introduced an instrument certifying process that is second to none in the industry.

4. A Brief History of Surgical Instruments

The history of surgical instruments has an important place within the history of medicine, as well as in the history of technology. Archaeologists have discovered primitive knives from as early as 10000 B.C., and there is evidence of attempts to suture from as far back as 2500 B.C.

Orthopedic surgery was also a very early concern. As far back as 5000 years ago the Egyptians used palm bark and linen bandages, wood and clay to stabilize fractures.

It was in Ancient Greece, however, that the precursor to modern instrumentation was born and orthopedic surgery came to prominence. The father of modern medicine, Hippocrates (460-ca. 377 B.C.), founded classical surgery. It is from Hippocrates that we have reports of instruments formed of hardened iron. In addition to iron and copper, bronze and brass were used to make instruments, which were either cast, forged or cold-worked. Some reports indicate the existence of as many as 200 instrument types.

After the decline of the Greek civilization, this development continued in the Roman Empire. Roman generals followed the motto "For the best legions, the best surgeons," and at those surgeons' disposal was a multitude of instruments including knives, saws, catheters, needles, forceps and specula. The Romans also knew how to make steel instruments. When the ancient city of Pompeii was discovered, archaeologists uncovered a large package of surgical instruments in a building which may have housed a very early surgical instrument business.

Large leaps in technology continued in the centuries to follow. Surgery came into its own as a discipline in the 1700's, and in the 1800's Paris became its center. To judge from archaeological finds, Germany by that time was also a center for instrument craftsmen. The invention of stainless steel in the twentieth century brought perhaps the greatest change to the manufacturing process, until the most recent event of minimally invasive instrumentation.

As surgery has developed, the trade of the instrument makers has developed alongside it. There is evidence that in ancient times there were metal craftsmen who specialized in the manufacture of medical instruments. Two of the very striking features of the ancient instruments were their good quality and their elaborate ornamentation. The purpose of the decorations was partly functional—they provided a more secure grip for the surgeon. In later periods, instruments were crafted by blacksmiths, cutlers and armourers. With the onset of the Industrial Revolution, and the general increase in the rationalization of production methods, instrument making advanced another step. It has continued to develop, to reach the high level of precision crafting we know today.

It was over 100 years ago that Tuttlingen, Germany became the center of high-quality instrument making. Today Tuttlingen continues to hold that position, with the majority of KMedic's manufacturing taking place there.

It is with a sense of history that we at KMedic go forward with the work of this ancient trade.

KMedic: In the Tradition of the Masters

Instrument making is a highly developed craft, and the craftspeople who make KMedic surgical instruments are the modern heirs to this ancient art. It is also a vocation that has respected its traditions over the centuries. So, while new techniques have kept pace with advances in surgical practices, the essence of the craft has changed very little. Today, computers and other advanced technology aid in the manufacture of instruments, but it remains the skills of gifted instrument makers that turn raw steel into the finely honed tools...ready for the surgeon's hand.

Evolving Tradition

As we're all aware, new surgical techniques create a continual need for improvements, as well as for the introduction of entirely new instruments. KMedic responds to these needs by forming partnerships with leading surgeons.

5. The Selection of KMedic Instruments

Recognizing the need of the orthopedic community for an easy, one-stop shopping resource for orthopedic instruments, KMedic responded by assembling the most comprehensive selection in the world.

In selecting our instruments we first assess the needs of the people who use them. In this process we consult with surgeons, nurses, techs, distributors, salespeople, engineers, instrument craftsmen and others familiar with the marketplace and the operating arena. If we perceive a large enough demand, we begin our product development process. This process typically contains the following steps:

5.1 Prototyping Stage

Samples are made and field tested. This process may go through several phases before the product is deemed useful and safe for general use in the market. As a result, this stage may take from three months to three years, depending on the complexity of the instrument.

5.2 First Article Sample (FAS) Stage

No product goes on to the next stage unless it has undergone rigorous testing by our Product Development and Quality Assurance (QA) departments. In the process we are guided by our mission statement, which spells out what our customers can expect from us:

“Because our products are used on human beings, we recognize a special responsibility to our customers. We will never knowingly sell an item that we would not have used on ourselves or on those we love.”

5.3 Tooling Stage

Usually prototypes are made by hand, with minimal use of machinery. Once the final shape and function have been determined, all the proper tooling for production can be made. The process can take from a few days to six months, again depending on the requirements.

5.4 Raw Material Selection

The identification and sourcing of the proper raw material is very important. There are many different specialty stainless steels available (see: "The Materials Used in Manufacturing," Section 7). We select the one which meets the requirements the instrument has to fulfill: cutting, clamping, retracting, etc.

At this point we also decide whether to use a hot-forged or a cold-stamped blank and whether the instrument needs to be tempered (see: "The Manufacture of KMedic Instruments," Section 6).

5.5 First Production

Once the raw material is available and the tools are completed, first production can begin. Depending on the instrument, the production process may require as many as 80 different steps.

5.6 Incoming Inspection

The first production receives special scrutiny from our QA department. A Device History Record (DHR) and a Device Master Record (DMR) is established, which will then contain all information about the product during its lifetime.

Once everything is in order, the QA department releases the product for sale.

5.7 Market Release and Follow-up

As the product goes out to a much larger user base, it is not unusual to make further refinements and improvements on the product. All of our products, new and old, are monitored to make sure they are functioning as expected, and we commonly make adjustments to even our long-established instruments.

This seven-step process may be abbreviated if prior raw material, tooling or product samples already exist. However, under no circumstances, do we skip any of the steps involved in assuring our KMedic quality. It is this process which allows us to proudly offer a lifetime guarantee for every KMedic Certified Instrument.

6. The Manufacture of KMedic Instruments

6.1 The People

Even with all the advances in technology, the craftsmen who make our instruments play a truly decisive role. They undergo many years of rigorous training before they are proficient in their trade. An apprentice system, supervised by master craftsmen who are both experts in the field and skilled teachers, ensures a steady influx of new instrument makers. This system also provides for the passing on of trade secrets from generation to generation. In addition, the KMedic German office employs its own *Chirurgiemechanikermeister*—a master craftsman of surgical instruments—and an instrument design engineer. They work very closely with our suppliers to ensure that the quality we demand is built into the product from the start.

6.2 The Tools of the Trade

Since there are thousands of different instruments, the processes naturally vary. While a typical instrument undergoes approximately 80 steps before completion, we will concentrate on the major steps.

6.3 Specifications

With every production order we place, we specify our requirements on the purchase order form, specification sheets, drawings, and in some cases, we supply samples.

6.4 Blanks

Every instrument starts out as a blank, or forging. There are generally two types: “hot forged” and “cold forged.” The majority of our instruments are hot forged. Using very expensive, high-precision tools, pieces of pre-cut stainless steel bar stock are heated to very high temperatures and literally shaped under the weight of a giant drop forge weighing many tons. The quality of the forgings is critical, as errors or poor quality cannot be corrected later in the process. Therefore, we are very careful in selecting our forgings.

Cold-forged blanks are made out of sheet metal or bar stock. Instead of being shaped under heat, they are shaped using the force of heavy hammers. Still other blanks are made using laser cutters or milling machines, which cut out or mill the desired shape.

6.5 Milling and Turning

Once the instrument maker has verified the quality of the blanks to be used, the next process is milling and/or turning. In the case of forceps, this process is used to create the basic shape of the box lock, jaws and ratchets.

6.6 Assembly

On a two-part instrument there is a male and a female part, which depending on the type of hinge used, are then assembled. A typical forceps has a box lock, which is created by widening the female part under heat and inserting the male part. They are then secured with a pin. Upon close inspection you can see the pin in a finished instrument.

6.7 Filing and Grinding

The shape of the metal is still quite rough at this point, so it is necessary to file and grind the instrument into its final shape. This is a process done entirely by hand and takes great skill.

6.8 Heat Treatment

Instruments requiring it undergo a process called heat treatment, tempering or hardening. This is necessary to make the instruments hard enough to withstand the rigors of their usage. The process differs somewhat according to the stainless steel chosen, but in all cases the stainless steel is brought to a very high temperature and then cooled until it has reached the proper hardness.

Achieving the right hardness is extremely important. If the steel is too soft, it will wear out or bend prematurely; if the steel is too hard, it will be brittle and break too easily.

The proper hardness is measured in units called Rockwell Hardness (HRC). A typical hardness range for a needle holder without tungsten carbide inserts is HRC 40–48. For scissors, the hardness ranges between HRC 50–58.

6.9 Fitting

After the heat treatment, the craftsmen proceed to fine-tune the shape and mechanism of the instrument. All unwanted sharp edges, burrs, etc. are removed so they will not inadvertently puncture the gloves of healthcare personnel. Scissors and other cutting instruments are sharpened and adjusted. It is at this point that skilled workers transform the piece of steel into the finely honed instrument surgeons rely on. This work is done entirely by hand.

6.10 Polishing

At this stage in manufacture the craftsmen proceed to the hand-polishing phase, which not only creates the aesthetic look of a well-made instrument, but—even more important—creates a homogeneous surface, a key element in rendering the instrument more corrosion resistant. Almost all KMedic instruments receive a silk matte or satin finish that reduces glare in the operating room. Great skill and experience are required to develop a good feel for the work, removing just enough surface irregularities while staying within the prescribed dimension limits.

In addition to hand polishing, the instruments now undergo electropolishing. This process chemically removes foreign substances and makes the surface even more corrosion resistant, creating a thin layer which acts as a protective film, known as passive or passivation layers. If properly cared for during use, these passive layers actually improve over time, ensuring the longevity of the instruments. (For more information about this, turn to Sections 7 and 12.)

6.11 Final Inspection

While quality is a concern at all points of the manufacturing and crafting process, it is at this stage that we demand a final inspection which checks the functionality, critical dimensions and surface conditions of the instrument. This inspection is performed by our manufacturers.

In addition, we perform our own independent inspection when the instruments are shipped to our U.S. facility. This rigorous process is addressed in section 8 "KMedic Quality Assurance."

7. The Materials Used in Manufacturing

7.1 Stainless Steel

The majority of KMedic instruments are manufactured from what is known as “stainless steel”. Stainless steel is not truly “stainless”, but rather a highly corrosion and rust-resistant alloy. The metal is extremely strong and durable and, more importantly, has a characteristic ability to form protective or “passivation” layers.

There are over 80 types of stainless steel manufactured, but only about a dozen of them are useful in making surgical instruments. The choice of steel is determined according to the desired flexibility, hardness, tensile strength and malleability. Some types of steel can be hardened, others cannot, depending primarily on the carbon content of the steel. The types are composed of varying amounts of iron ore and chromium. It is the large quantities of chromium which give the steel its “stainless” properties. The chromium forms a thin layer on the surface, known as a “passive layer,” which protects against corrosion. This layer acts as an invisible patina and with correct care and handling, repeated use and exposure to air, the instruments become increasingly corrosion resistant.

Many KMedic surgical instruments, including forceps, rongeurs and curettes, are made of the German steel type known as “1.4021”. This type is approximately equivalent to the American steel type 420.

Steel type 1.4021 is composed primarily of iron. The other components are as follows:

Carbon	0.17-0.25%
Silicon	≤ 1.0%
Manganese	≤ 1.0%
Phosphorous	≤ 0.045%
Sulphur	≤ 0.043%
Chromium	12.0-14.0%

While every effort is made during the manufacturing process to ensure that the instruments are corrosion resistant, the key to longevity is proper maintenance. When not properly treated, stainless steel can rust and stain, reducing the life of the instrument or rendering it useless. For more detailed information on instrument care, see “KMedic Instrument Care Instructions”, Section 12.

7.2 Tungsten Carbide

Tungsten carbide (TC), an alloy of tungsten and carbon, is used in the manufacture of such instruments as needle holders, scissors, pin cutters, pliers and wire tighteners. Since the TC is harder than the steel used in needles, pins and wires, it results in instruments with exceptional durability. Usually the TC is soldered or welded to the jaws or working ends of instruments. TC inserts that are soldered can be separated from the instrument and replaced when they become worn. TC that is welded to the stainless steel cannot be separated, and therefore is not replaceable.

7.3 Aluminum

Certain instrument parts and cases are manufactured from aluminum, which is lightweight. Aluminum is treated with an electrochemical process called anodization. This process forms an oxide layer on the surface of the aluminum. The oxide layer can be colored with pigments and offers good corrosion resistance. Certain cleaners, disinfectant solutions and abrasive brushes can damage the protective layer.

7.4 Plastics

KMedic also uses a range of plastics in the manufacture of handles and other parts. They are specially formulated to withstand normal sterilizing temperatures. Many handles of screwdrivers are made from a substance known as phenolic, which is autoclavable up to 250° Fahrenheit.

7.5 Titanium

Titanium is becoming more widely used, particularly in the manufacture of implantation devices used to repair fractures, e.g., plates and screws. Titanium is an appealing choice for implants because of its proven biocompatibility. The high cost of using titanium for instrument manufacture is often prohibitive. It is therefore primarily used in the manufacture of microsurgical instruments, where its light weight is an important factor in avoiding surgeon fatigue. KMedic does not currently have any titanium instruments listed in our Sourcebooks, but they are available on a custom-order basis.

7.6 Chrome Plating

Chrome plating may be applied to brass or nonstainless, so-called carbon steel. While used widely in the past, chrome-plated instruments have been made all but obsolete by stainless steel. In the KMedic product line, many chrome instruments have been replaced by stainless steel, because of the tendency of the chrome layer to chip. Once chipped, the carbon layer beneath is exposed, which can contaminate fine stainless steel instrumentation. In the long run, stainless steel is the most economical choice. Among other things, stainless steel can be resharpened; chrome instruments cannot.

This covers the materials used most frequently in the manufacture of surgical instruments. Some instruments may contain other substances; that information may be found under the product description in our Sourcebooks. If we do not mention a specific material in our Sourcebooks, then the instrument is made from stainless steel.

8. KMedic Quality Assurance

KMedic instruments are the result of a working knowledge of the surgeon's art, exacting manufacturing specifications and strict adherence to our Quality Assurance program. From its origins as an idea, to the crafting of the prototype, to its appearance on a surgical tray, it takes more than 80 steps to create a KMedic Certified Instrument. Every finished instrument is the result of years of performance monitoring and improvements.

Superior quality is built into our instruments at every stage of the manufacturing process. Nevertheless, before our instruments find themselves in a surgeon's hand, they are subject to a final inspection process, performed by specially trained personnel, which includes:

- Inspection against a master sample and/or drawing to assure identity and pattern consistency
- Exacting caliper and micrometer measurements of critical dimensions
- Function tests to ensure adherence to performance standards
- Surface audits to detect imperfections, unwanted sharp edges, burrs and other irregularities. This is important to assure corrosion resistance and safety. Safety is an issue when non-functional sharp edges or burrs are present which could snag or tear rubber gloves and jeopardize safety
- Tungsten carbide inserts should be inspected to make sure the tips have been cleanly soldered without voids, as well as for any excess soldering material
- Corrosion and hardness tests to guarantee functionality and longevity
- Marking to ensure proper manufacturing coding, sizing, identification numbers and maximum capacities
- Regular checks for material and hardness certifications

The following provides an abbreviated look at our QA instructions to check performance criteria for specific product groups:

8.1 Scissors

Perform cutting tests with our testing material. Scissors must not snag the test material. Scissors must not bind when cutting appropriate layers. The heavier the scissors, the more layers of material they must cut. The blades must run smoothly, without much hesitation in the closing process. Check for burrs, especially at the tip of cutting edge. If present, hesitation will usually result when closing the scissors. Make sure screw lock is secure and proper play exists when opened.

8.2 Forceps

Check against a light source to ensure that no substantial amount of light passes through closed jaws. Do clamp tests by pressing the jaws together on a plastic surface. The impression on the plastic should be clear and consistent. Teeth must fit together closely. Jaws must be aligned correctly. Ratchets must engage crisply, yet smoothly. When ratchets are engaged at the first ratchet they should not open when the instrument is lightly tapped against the edge of a table.

8.3 Needle Holders

The jaws of needle holders must close tightly so that little or no light shines through the front 2/3 of the closed jaws. Must hold suture material. Do ratchet and clamp tests as with forceps.

8.4 Retractors

Check ratchets for proper holding action. Check tips for sharp, blunt or semisharp edge. Check all edges for nonfunctional sharpness. Make sure mechanisms work smoothly, e.g., thumb ratchets, etc. Check holding power with ratchet engaged. Make sure ratchet teeth engage properly.

8.5 Cutting Forceps

Perform cutting tests with the appropriate testing material. Generally, cutting forceps are required to cut cleanly with the front half of the jaws. Make sure tips close properly from the top to the middle of the jaws. Make sure cutting edges don't spread at the very tip when jaws are closed.

8.6 Pin and Wire Cutters

Perform cutting tests with the appropriate pin or wire according to maximum capacity etched on instruments.

8.7 Implant Management Instruments

Instruments used to implant wires, screws and plates are subject to very strict dimensional and functional inspections because they have to mate in the field with a variety of other implants and instruments, often made by different manufacturers. A screwdriver which does not fit the head of a screw is useless.

See charts at the beginning of Section R in our Orthopedic Sourcebook for a guide on how the instruments fit together.

8.8 Dimension

Overall Length

Overall length is measured with different tools, depending on the tolerance required. It is possible that some instruments will vary as much as 1/2" from the length specified in the Sourcebook description. This is true only in cases where the overall length is not critical. Thus an instrument listed as 6" long may actually be between 5 1/2" and 6 1/2" long. This variance is industry convention, and is the result of metric European sizes being rounded off when converted to inches. To ensure pattern consistency, we also compare the overall length to our master sample or drawing to verify the correct length.

Critical Dimensions

Tip details and other important dimensions are measured with calipers, micrometers or other specially built gauges and must meet predetermined tolerances.

Once instruments have gone through this inspection process, they are qualified to be KMedic Certified and they are ready to be used.

Section B

9. Classification by Usage

Surgical instruments are designed to perform either diagnostic or therapeutic operations—to locate the cause of a problem, or to treat a problem once it has been found. Each of the tens of thousands of surgical instruments is designed to perform a specific function. Those functions may be generally categorized under one of the following uses:

to cut or incise:

Instruments used for this purpose are frequently referred to as “sharps”. They include scissors, knives, scalpels, chisels and osteotomes, among others.

to retract:

Hand-held and self-retaining retractors serve this purpose, as well as instruments such as skin and bone hooks.

to grasp, hold or occlude:

These include the many types of forceps, including hemostats, dressing and tissue forceps, as well as bone holding forceps. Also included in this group are needle holders.

to dilate or probe:

These instruments are used to dilate or enlarge openings or to find an area or foreign object.

to cannulate or drain:

These instruments—including catheters, drains and cannulas, are generally used to drain a wound.

to aspirate, inject or infuse:

These instruments serve to remove unwanted fluids as well as to inject needed fluids into a patient. Among these instruments—syringes, some needles, trocars and cannulas.

to suture or ligate:

Suture or ligation is used to close or rejoin a wound or an area of operation, e.g., a vessel, a nerve or tissue. There are a variety of sutures and clips, as well as suture needles and ligating instruments.

10. Basic Identification and Anatomy of Surgical Instruments: An Illustrated Guide

Instrument Naming

The major sources for the naming of instruments are:

- inventors and doctors , e.g., the Dr. “Lambotte Osteotomes”
- function, e.g., the “ Periosteal Elevator”
- appearance, e.g., ”Mosquito Forceps”
- nicknames, e.g., “Mother-in-law” forceps

Especially in the beginning it is easiest to remember the proper names of the instrument and not to worry about the nicknames. Nicknames can vary depending on geographic region and individual hospital.

In This Section	Page #
Joint Types	B3
Handle Types	B4
Retaining Systems	B5
Blade Curvature Types	B7
Blade Types	B9
Bone Holding Types	B13

Joint Types

box lock

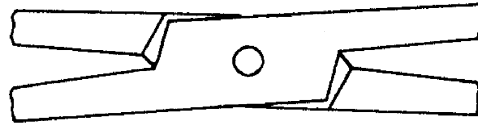

lap joint

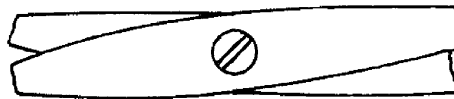

double-action joint

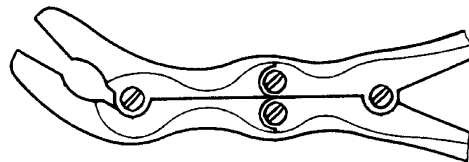

Handle Types

ring handle

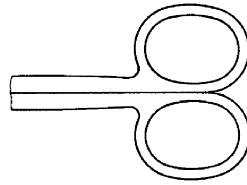

ring handle with one extra large handle

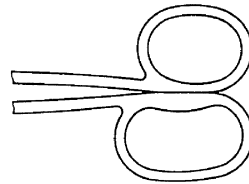

grooved handle

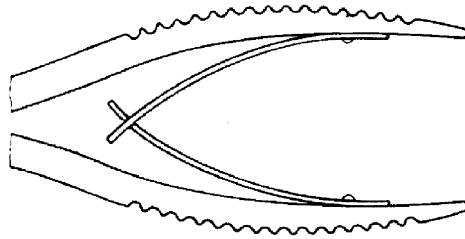

grooved handle with horn

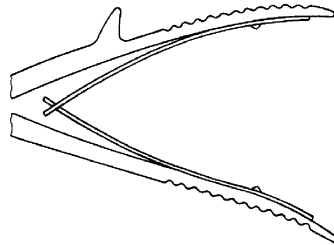

hollow handle

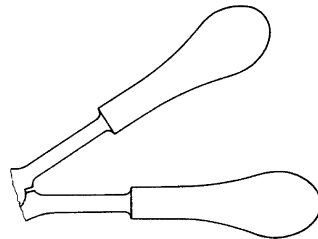

Retaining Systems

ratchet lock

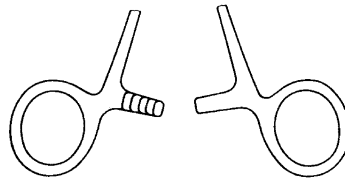

single spring

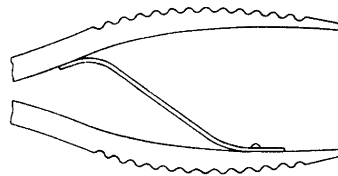

double spring

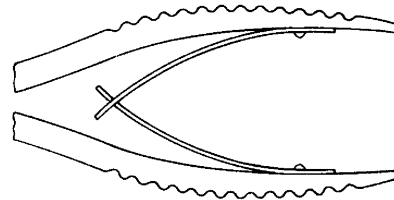

spring with roller

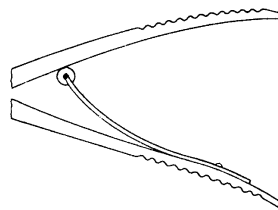

double spring
with ball and socket joint

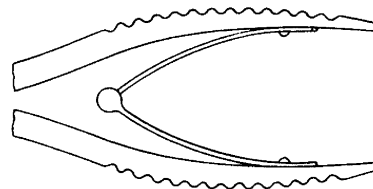

Retaining Systems

double leaf spring



cam ratchet

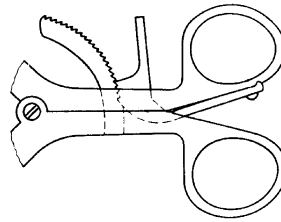

bar and wingnut

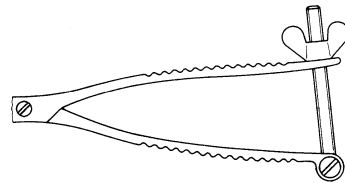

sliding ring

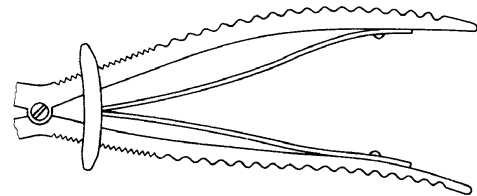

bar ratchet

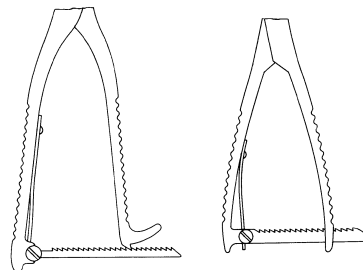

Blade Curvature Types

straight

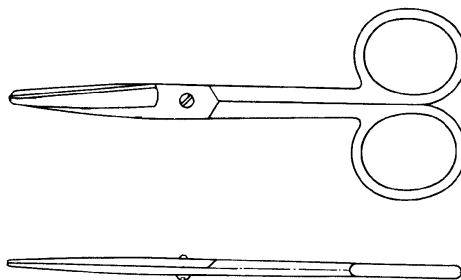

curved on flat

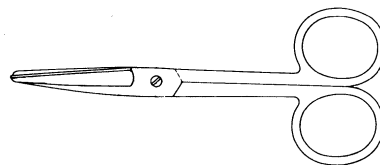

slightly curved



strongly curved



curved on flat, s-shaped

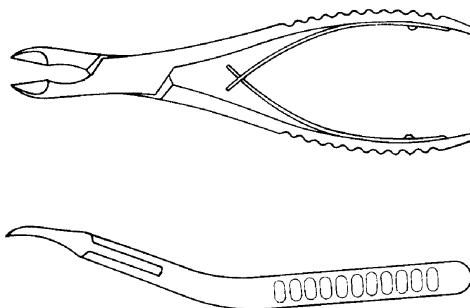

Blade Curvature Types

laterally curved

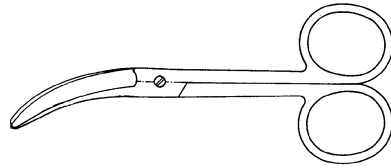

laterally angled

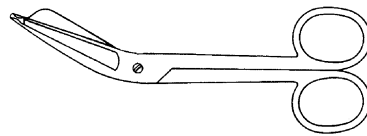

angled on flat

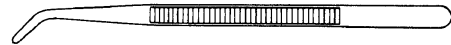

bayonet-shaped



bayonet tip

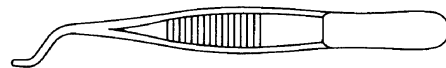

Blade Types

blunt, blunt

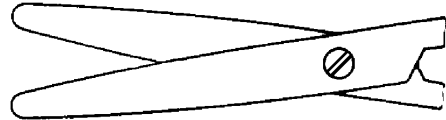

blunt, blunt with bevel



sharp, blunt

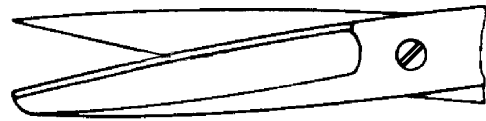

angled on flat

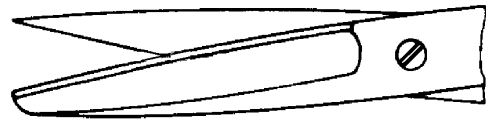

sharp, sharp



fine tip, sharp

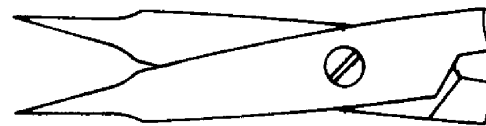

fine tip, blunt

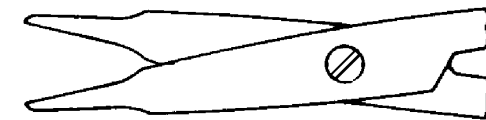

sharp with ball end

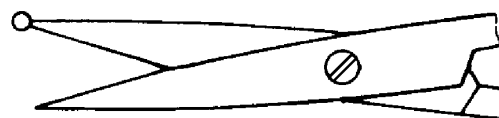

Blade Types

blunt with round probe end

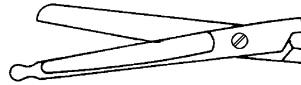

blunt with retaining hook

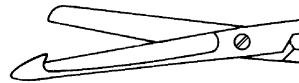

blunt with probe end

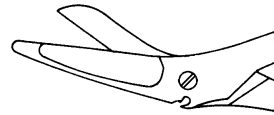

angled on flat

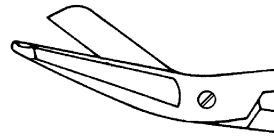

blunt with spade probe end

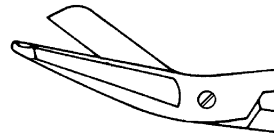

blunt, blunt, triangular section

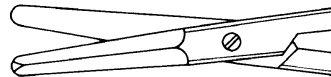

serrated dissector end

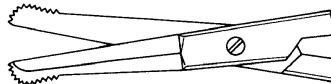

blunt, one hook end

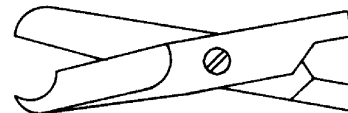

Blade Types

fine, straight jaw

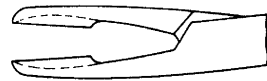

round jaw

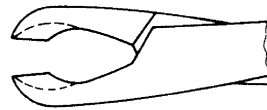

square jaw

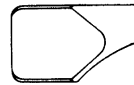
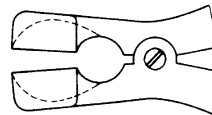

curved on flat

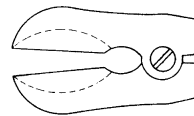

straight or angled
on flat

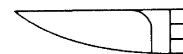
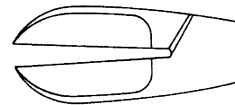

Blade Types

concave cutting jaw

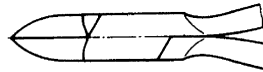

end-cutting, straight jaw

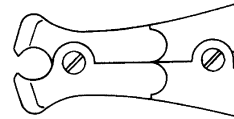

end-cutting, concave jaw

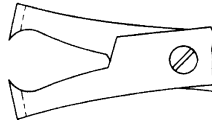

punch upward
through cutting

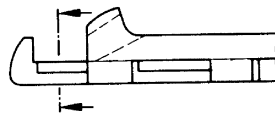

punch upward oblique
not through cutting

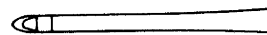
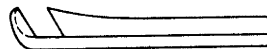

Bone Holding Jaw Types

bone holding

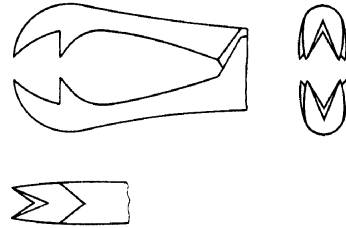

bone holding
semb

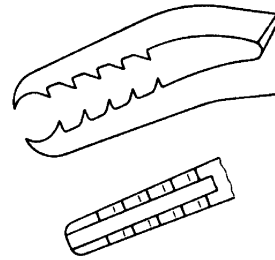

bone holding
farabeuf

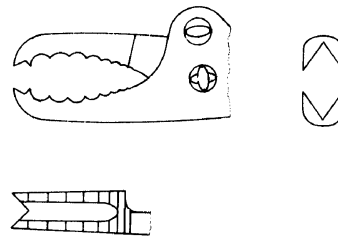

bone holding
langenbeck

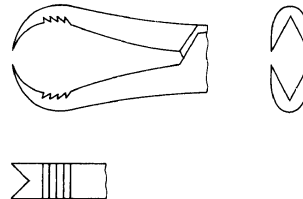

11. About KMedic Instruments: Major Product Groups

This portion of the manual addresses KMedic's instrument product groups. You will find information about the materials used to make the instruments, where they are generally used, the important features of each product, as well as tips for usage and care. The products are arranged to correspond to the order established in the KMedic Orthopedic Sourcebook. Below is a detailed table of contents for the instruments in this section. This is intended as an overview of the main product groups—for information about products not listed below, refer to the KMedic Orthopedic Sourcebook.

In This Section	Page #
Scalpel Handles	B17
Scissors	B19
Supercut Scissors	B23
Operating Scissors	B25
Dissecting Scissors	B27
Tungsten Carbide Scissors	B29
Forceps	B31
Hemostatic Forceps	B33
Towel and Sponge Forceps	B35
Dressing/Thumb Forceps	B37
Tissue Forceps	B39
Stainless Steel Needle Holders	B41
Tungsten Carbide Needle Holders	B43
Olsen Hegar Needle Holders	B45
Microsurgical Instruments	B47
Retractors	B49
Hand-Held Retractors	B51
Self-Retaining Retractors	B53
Elevators	B55
Awls	B57
Bone Hooks	B63

In This Section	Page #
Bone Holding Forceps	B63
Cartilage and Tendon Instruments	B65
Bone Curettes	B67
Osteotomes, Chisels and Gouges	B69
Mallets	B71
Tamps	B73
Bone Files and Rasps	B75
Bone Cutters, Trephines and Bone Rongeurs	B81
Bone Saws and Bone Knives	B83
Spinal Rongeurs (Neuro Rongeurs)	B89
Plaster Cast Instruments	B91
Wire and Pin Implants	B95
Wire and Pin Cutters	B97
Wire and Pin Management Instruments	B99
Hand Drills	B101
Bone Screws	B103
Bone Plates	B105
Drill Bits	B107
Countersinks	B109
Taps	B111
QC (Quick-Coupling) Handles	B113
Depth Gauges	B115
Drill Sleeves and Guides	B117
Screwdrivers	B119
Bending Templates	B121
Plate Bending Instruments	B123
Instrument Racks	B125

Soft Tissue Instruments

Scalpel Handle #4
KM 29-060

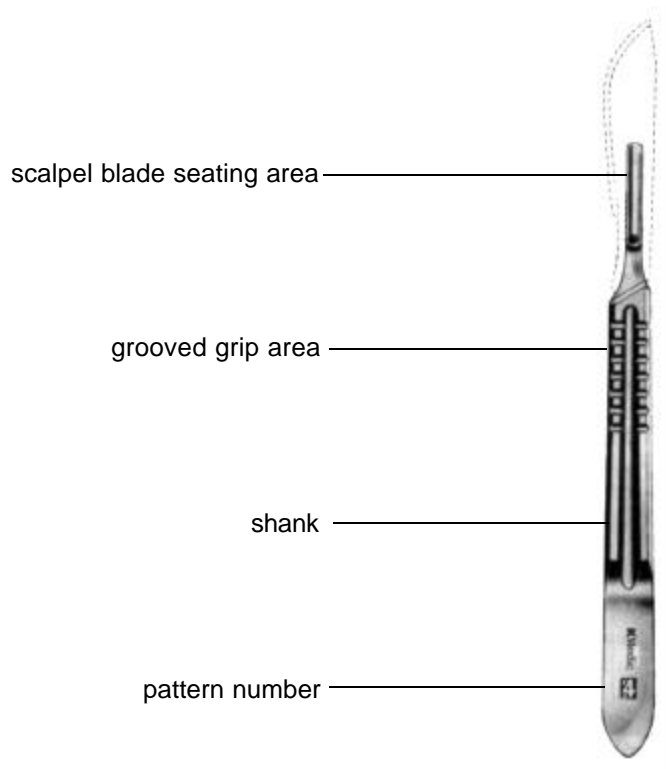

KMedic Product Information

Instrument type/name:	Scalpel Handles
aka:	
Raw material:	Forgings from stainless steel
Surface:	Silk matte satin finish
Main function:	To hold scalpel blades
Where used mostly:	All surgery
Important product features:	Many different types of handles are used. The different styles are numbered and hold a variety of scalpel blade sizes.
Useful hints in usage:	Extreme care must be taken when attaching and removing the scalpel blades.
Special care instructions:	
Other comments:	Disposable blade and handle combinations are widely available from different manufacturers.

KMedic Product Information

Instrument type/name:	Scissors
aka:	Sharps
Raw material:	Forgings from stainless steel
Surface:	Silk matte satin finish
Main function:	To cut and dissect tissue To cut sutures, clothing, bandages
Where used mostly:	All surgery
Important product features:	Scissors come in a tremendous variety of styles and sizes. They come in straight, curved and angular versions. When opened as wide as possible, well-made scissors will have a lot of play at the hinge. This is not a sign of malfunction but a required design feature. Some scissors have serrated blades. Serrations can also be added to most patterns by special order. Some doctors prefer the serrated blades because they believe it helps prevent tissue slippage.
Useful hints in usage:	The curved patterns are preferred by most surgeons for dissecting, since they provide a better field of vision for the areas to be cut. Straight scissors are used when a straight cut is desired, such as in sutures, nerves, vessels. Scissors are also used to spread and probe the area of incision. The smaller sizes are used at the surface, the larger sizes deeper in the cavities. Dedicate the different types for their specific purpose—for example, using fine dissecting scissors to cut suture can ruin the cutting edge.
Special care instructions:	To maintain scissors in peak operating condition, they must be sharpened regularly.
Other comments:	The most popular model of suture and wire cutting scissors is KM 35-068. The most popular model of bandage scissors is KM 31-692.

Instrument subtypes:

Super-Cut Scissors
Tungsten Carbide Scissors
Operating Scissors
Suture and Wire Cutting Scissors
Dissecting Scissors
Bandage Scissors

Scissors

Super-Cut Mayo Scissors
KM 35-280

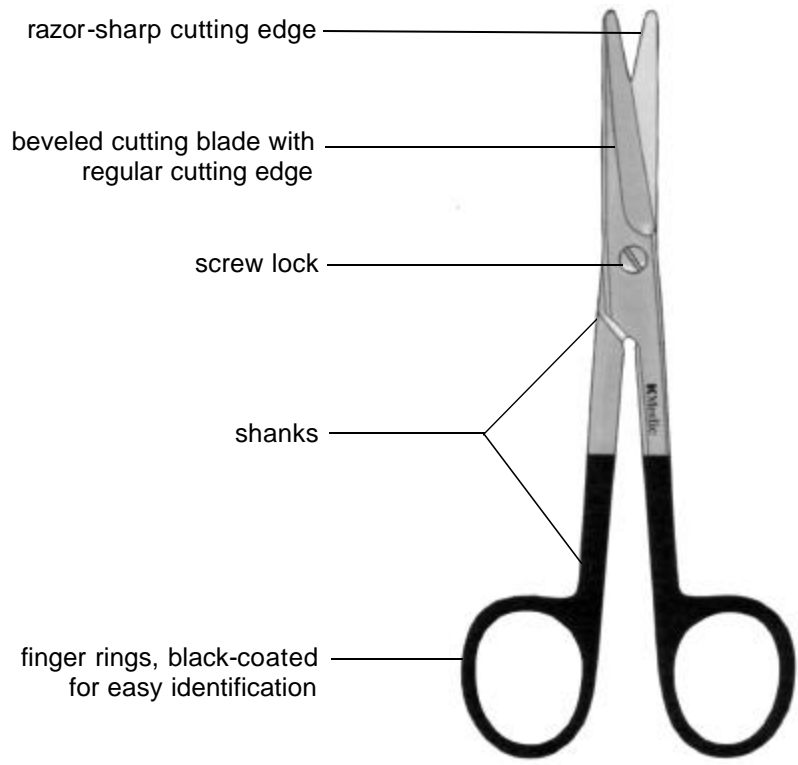

KMedic Product Information

Instrument type/name:	Super-Cut Scissors
Raw material:	Forgings from stainless steel
Surface:	High polish finish Black handles for easy identification
Main function:	To cut and dissect tissue To cut sutures, clothing, bandages
Where used mostly:	General surgery
Important product features:	They come in many styles. Super-Cut Scissors have one razor-sharp cutting edge and one regular cutting edge. They have superior cutting ability because of the improved geometry and cutting action. The advantages are: -More control and precision -Reduction of hand fatigue -Edges retain sharpness longer
Useful hints in usage:	Dedicate the different types for their specific purpose—for example, using fine dissecting scissors to cut suture can ruin the cutting edge.
Special care instructions:	To maintain scissors in peak operating condition, they must be sharpened regularly. Special razor edge requires special sharpening requirements.
Other comments:	The most popular types are the Mayo and Metzenbaum. On special request one blade can be serrated.

Scissors

Operating Scissors
KM 33-320

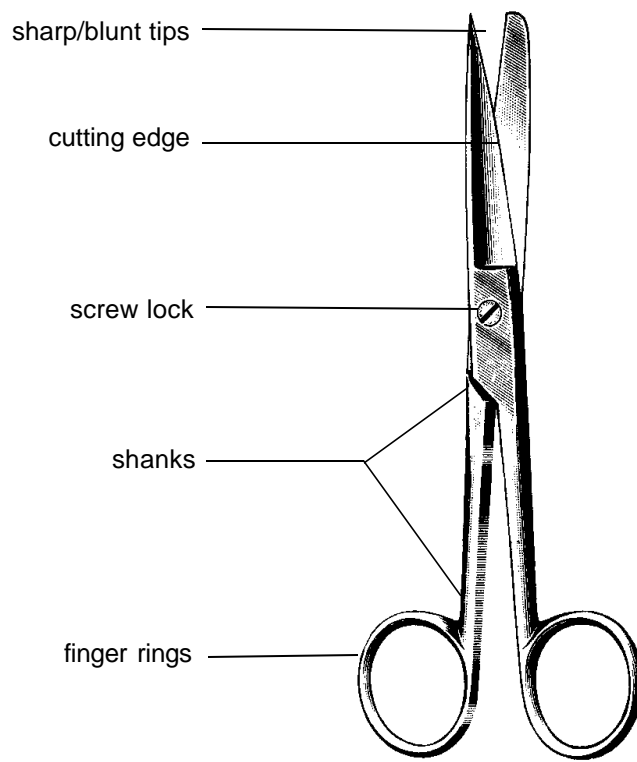

KMedic Product Information

Instrument type/name:	Operating Scissors
Raw material:	Forgings from stainless steel
Surface:	Silk matte satin finish
Main function:	To cut suture, gauze and other materials
Where used mostly:	General surgery
Important product features:	
Useful hints in usage:	
Special care instructions:	To maintain scissors in peak operating condition, they must be sharpened regularly.
Other comments:	The most popular model of Operating Scissors is KM 33-320.

Scissors

Metzenbaum Scissors
KM 34-458

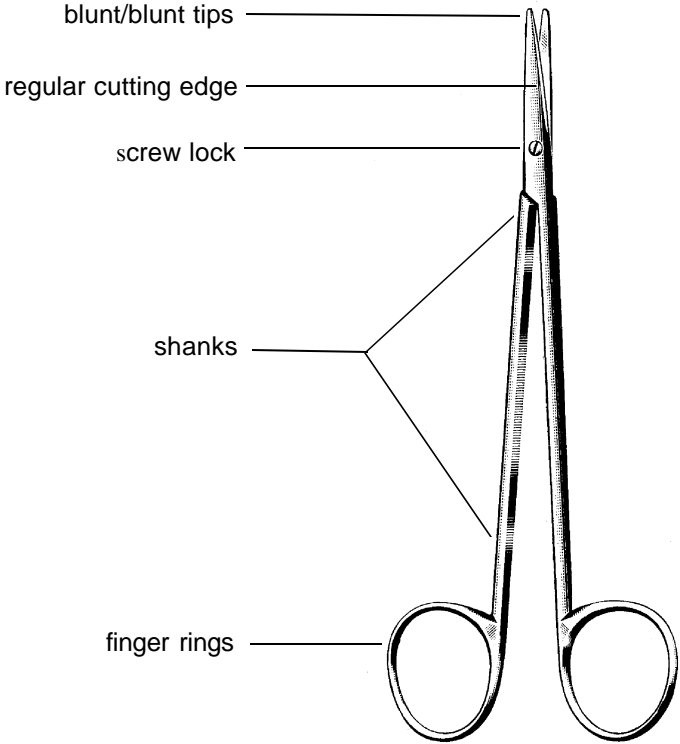

KMedic Product Information

Instrument type/name:	Dissecting Scissors
Raw material:	Forgings from stainless steel
Surface:	Silk matte satin finish
Main function:	To dissect tissue
Where used mostly:	General surgery
Important product features:	The curved pattern is preferred by most surgeons for dissecting, since it provides a better field of vision for the areas to be dissected. The very tips of scissors are also used to spread and probe the area of incision. The smaller sizes are used at the surface, the larger sizes deeper in the cavities.
Useful hints in usage:	
Special care instructions:	To maintain scissors in peak operating condition, they must be sharpened regularly.
Other comments:	The most popular types of dissecting scissors are Mayo, Metzenbaum, Iris and Stevens Scissors. For small dissecting scissors surgeons often prefer the Stevens Tenotomy Scissors.

Scissors

TC Mayo Scissors
KM 35-620

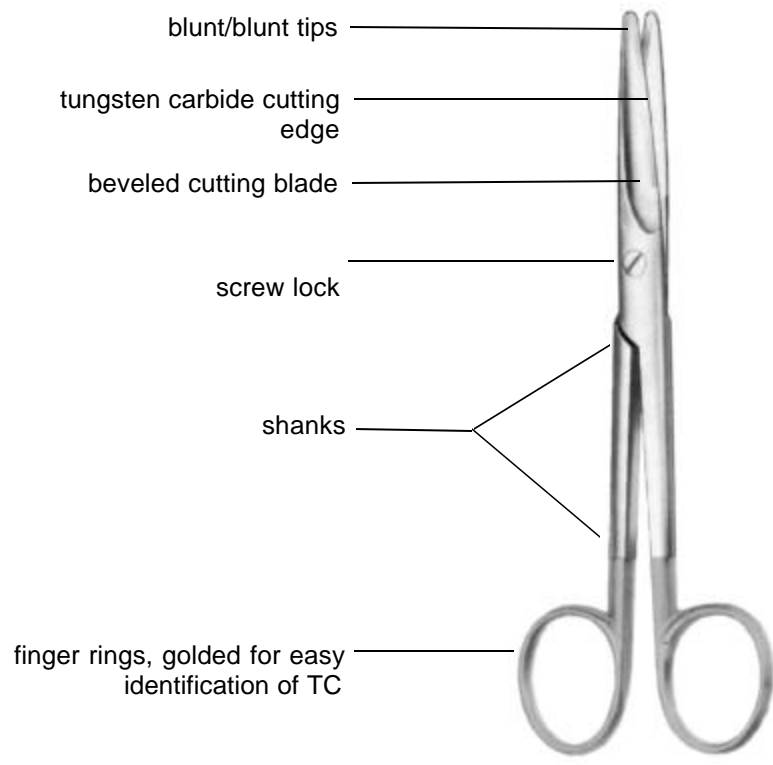

KMedic Product Information

Instrument type/name:	Tungsten Carbide Scissors
Raw material:	Forgings from stainless steel Tungsten carbide in the cutting edges
Surface:	Silk matte satin finish Gold-plated ring handles for easy identification
Main function:	To cut and dissect tissue To cut sutures, clothing, bandages
Where used mostly:	General surgery
Important product features:	Tungsten Carbide scissors provide greater durability.
Useful hints in usage:	
Special care instructions:	To maintain scissors in peak operating condition, they must be sharpened regularly.
Other comments:	The most popular types are the Mayo and Metzenbaum.

KMedic Product Information

Instrument type/name:	Forceps
Raw material:	Forgings from stainless steel
Surface:	Silk matte satin finish
Main function:	To grasp, hold firmly or exert traction upon tissue or material
Where used mostly:	General surgery
Important product features:	Forceps represent the most widely used design form in surgical instruments.
Useful hints in usage:	
Special care instructions:	
Other comments:	
Instrument subgroups:	Hemostatic Forceps Tissue Forceps Towel Forceps Sponge Forceps Dressing Forceps Splinter Forceps Bone Holding Forceps

Hemostatic Forceps

Halsted Mosquito Forceps
KM 36-156

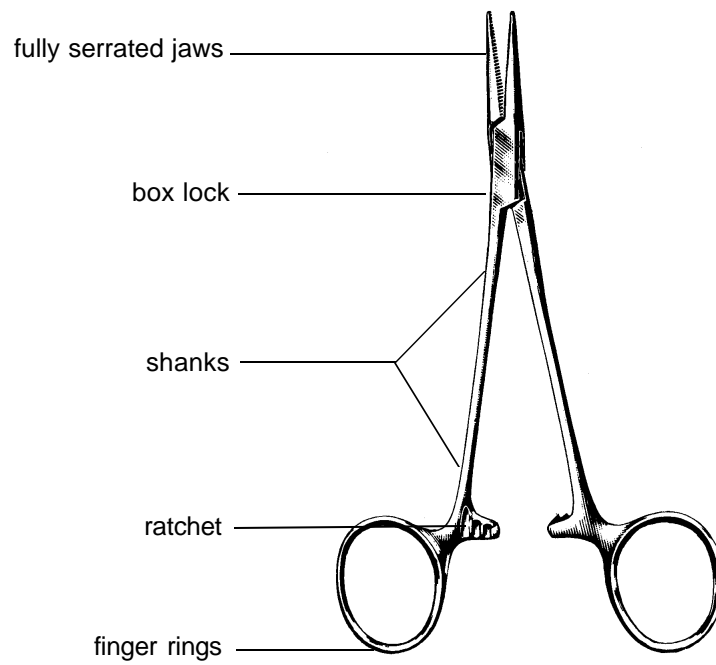

KMedic Product Information

Instrument type/name:	Hemostatic Forceps
aka:	Artery Forceps, Clamps and Snaps
Raw material:	Forgings from stainless steel
Surface:	Silk matte satin finish
Main function:	To clamp and restrict arteries or tissue, to control the flow of blood
Where used mostly:	General surgery
Important product features:	They have fine serrations of varying lengths in the jaws.
Useful hints in usage:	
Special care instructions:	
Other comments:	Some patterns are available with sharp teeth in the jaws. The most popular patterns are Mosquito KM 36-158 and Kelly KM 36-166.

Towel Forceps

Backhaus Towel Forceps
KM 37-462

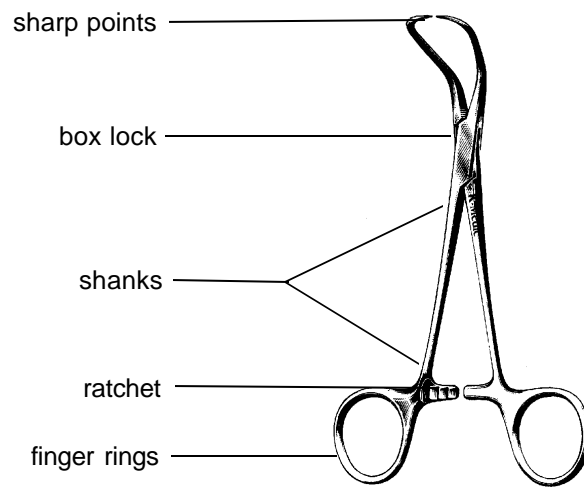

KMedic Product Information

Instrument type/name:	Towel and Sponge Forceps
Raw material:	Forgings from stainless steel
Surface:	Silk matte satin finish
Main function:	To attach towels, to handle sponges and other material
Where used mostly:	General surgery
Important product features:	
Useful hints in usage:	
Special care instructions:	
Other comments:	The most popular type is the Backhaus.

Dressing/Thumb Forceps

Adson Dressing Forceps
KM 39-062

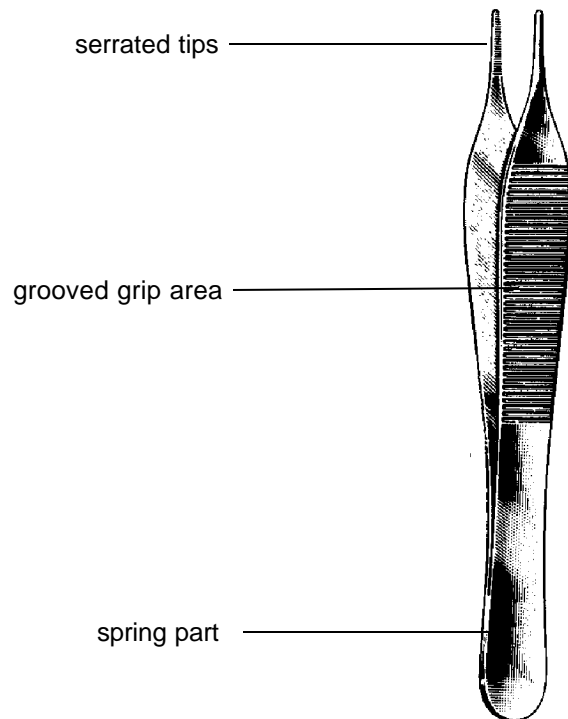

KMedic Product Information

Instrument type/name:	Dressing/Thumb Forceps
aka:	Pick-ups
Raw material:	Stainless steel Both hot-forged and cold-stamped blanks are used.
Surface:	Silk matte satin finish
Main function:	To grasp and handle dressing and other material
Where used mostly:	General surgery
Important product features:	Tweezer-type forceps are generally serrated, without teeth. They come in many sizes and shapes.
Useful hints in usage:	
Special care instructions:	
Other comments:	The most popular model is the Adson KM 39-062.

Tissue Forceps

Adson Brown Tissue Forceps
KM 39-092

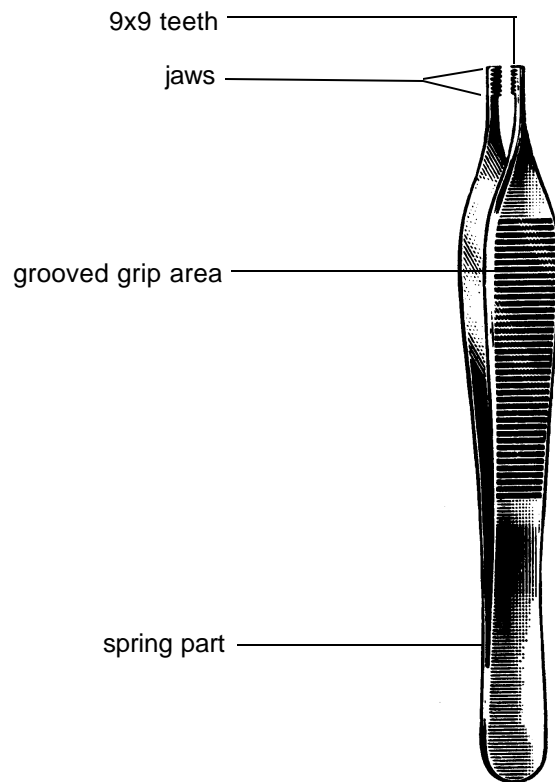

KMedic Product Information

Instrument type/name:	Tissue Forceps
Raw material:	Stainless steel Both hot-forged and cold-stamped blanks are used.
Surface:	Silk matte satin finish
Main function:	To grasp and handle soft tissue
Where used mostly:	General surgery
Important product features:	Tips usually have teeth and/or serrations to hold tissue securely. Some varieties have delicate, atraumatic serrations in order to lessen the impact on the tissue held. They are available both in a ring-handle and tweezer-type design.
Useful hints in usage:	
Special care instructions:	
Other comments:	The most popular models are the Allis KM 43-112 and the Adson KM 39-066.

Needle Holders

Mayo Hegar Needle Holder, serrated
KM 41-270, regular
KM 41-302, with TC insert

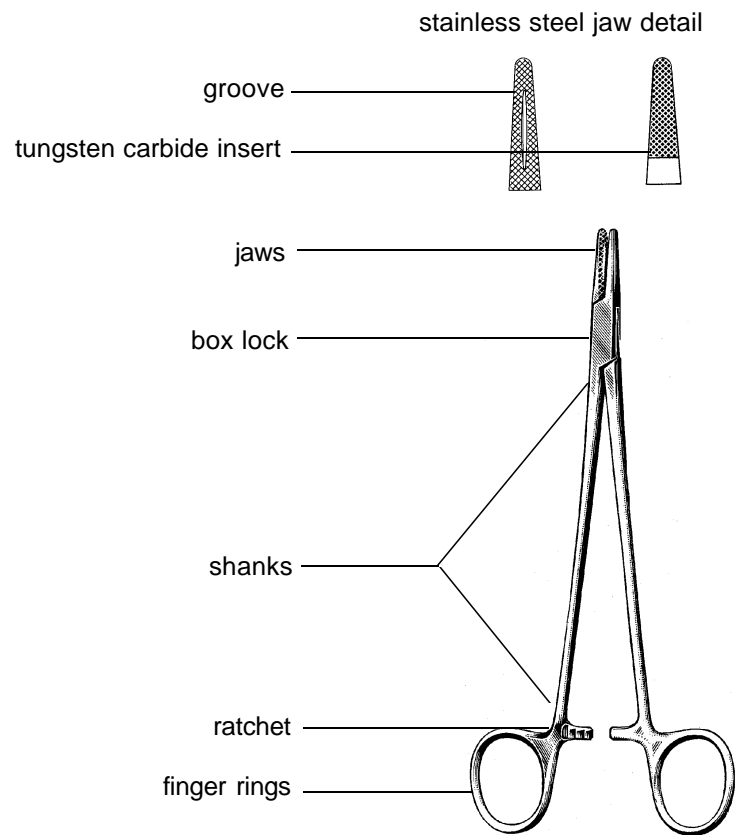

KMedic Product Information

Instrument type/name:	Stainless Steel Needle Holders
aka:	Needle Drivers, Drivers
Raw material:	Forgings from stainless steel
Surface:	Silk matte satin finish
Main function:	To hold and guide suture needles securely for suturing
Where used mostly:	All surgery
Important product features:	The jaws are milled for nonslip grip on needle. The jaws of regular stainless steel needle holders cannot be replaced; in many situations the TC needle holder is therefore the more economical choice.
Useful hints in usage:	They look similar to hemostats, but jaws are thicker and shorter. They are available in many styles and sizes. Shorter ones are used for working close to the surface. Longer ones are for deeper cavities. The smaller the needle, the smaller the jaws of the needle holder. If the needle is too large to be held securely, select a larger size needle holder. Otherwise, the needle may slip, or the needle holder may be overstressed, causing fatigue or breakage.
Special care instructions:	
Other comments:	The most popular type is the Mayo Hegar 6" KM 41-272
Instrument subtypes:	

KMedic Product Information

Instrument type/name:	Tungsten Carbide (TC) Needle Holders
aka:	Needle Drivers, Drivers
Raw material:	Forgings from stainless steel Tip inserts from tungsten carbide
Surface:	Silk matte satin finish Gold-plated handles identify the Tungsten Carbide tips
Main function:	To hold and guide suture needles securely for suturing
Where used mostly:	All surgery
Important product features:	Tungsten carbide inserts in jaws are harder than needle steel. Precision-milled inserts provide a nonslip grip. They have exceptional durability. The jaws of a TC needle holder can be replaced when worn. The jaws of regular stainless steel needle holder cannot be replaced; in many situations the TC Needleholder is therefore the more economical choice.
Useful hints in usage:	They look similar to hemostats, but jaws are thicker and shorter. They are available in many styles and sizes. Shorter ones are used for working close to the surface. Longer ones are for deeper cavities. The smaller the needle, the smaller the jaws of the needle holder. If the needle is too large to be held securely, select a larger size needle holder. Otherwise, the needle may slip, or the needle holder may be overstressed, causing fatigue or breakage.
Special care instructions:	
Other comments:	The most popular model is the 6" Mayo Hegar KM 41-302.
Instrument subtypes:	

Needle Holders

Olsen-Hegar Needle Holder
KM 41-428

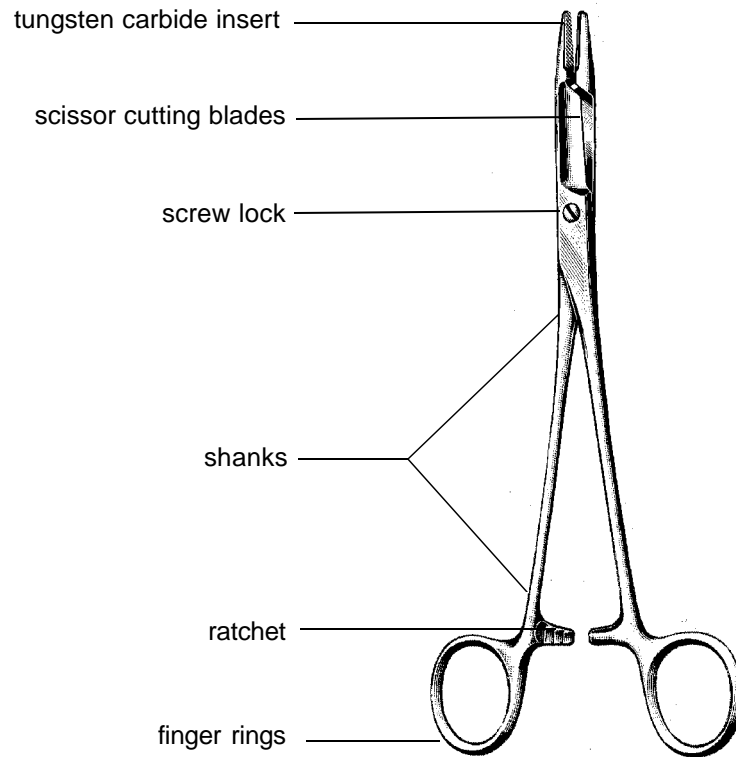

KMedic Product Information

Instrument type/name:	Olsen Hegar Needle Holders
aka:	Needle Driver, Drivers
Raw material:	Forgings from stainless steel They are available with and without TC inserts
Surface:	Silk matte satin finish Gold-plated handles identify the Tungsten Carbide tips
Main function:	To hold and guide suture needles securely for suturing. This is a combination scissors and needle holder, which speeds up the suturing process.
Where used mostly:	Veterinary, podiatric and dental surgery, where assistants are often not available
Important product features:	Tungsten carbide inserts in jaws are harder than needle steel. Precision-milled inserts provide a nonslip grip. They have exceptional durability. The jaws of a TC needle holder can be replaced when worn. The jaws of regular stainless steel needle holders cannot be replaced; in many situations the TC needle holder is therefore the more economical choice.
Useful hints in usage:	Shorter ones are used for working close to the surface. Longer ones are for deeper cavities. The smaller the needle, the smaller the jaws of the needle holder. If the needle is too large to be held securely, select a larger size needle holder. Otherwise, the needle may slip, or the needle holder may be overstressed, causing fatigue or breakage.
Special care instructions:	Delicate needle holders are easily overstressed if used with a needle which is too long—choose the appropriate size.
Other comments:	The most popular model is KM 41-428.
Instrument subtypes:	

Microsurgical Instruments

Micro Scissors
KM 44-018

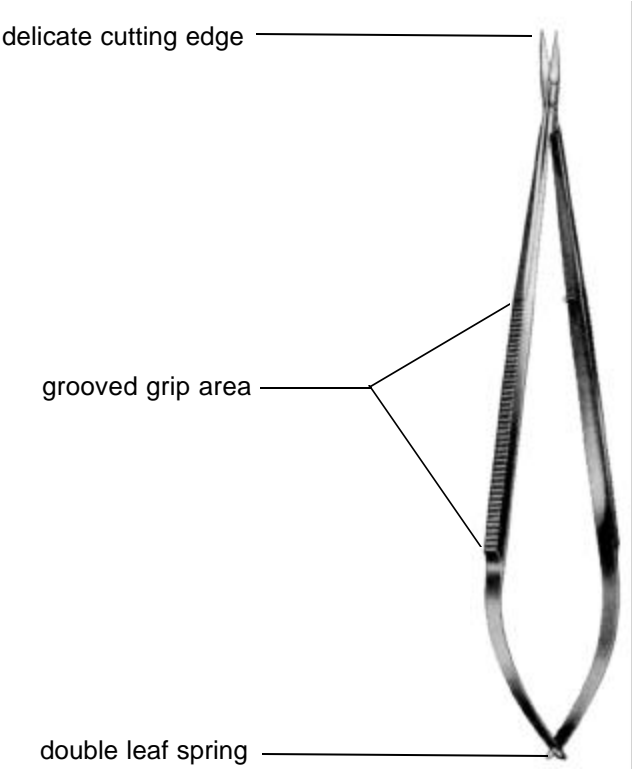

KMedic Product Information

Instrument type/name:	Microsurgical Instruments
Raw material:	Forgings from stainless steel
Surface:	Silk matte satin finish
Main function:	To perform the delicate tasks of dissecting, cutting, holding, clamping, manipulating and suturing tissue in hand surgery
Where used mostly	Hand surgery
Important product features:	They are specially designed for the needs of microsurgery. There is a variety of sizes and styles available. They are lightweight and delicate.
Useful hints in usage:	Because of their delicate design, take care not to overstress the instruments.
Special care instructions:	Microsurgical instruments should be handled with great care to avoid damaging their delicate mechanisms.
Other comments:	Sterilization and instrument cases are available. They are also available in large or small sets.
Instrument subtypes:	Microsurgical Scissors Microsurgical Forceps Microsurgical Clamps Microsurgical Needle Holders

Retractors

Volkman Finger Retractor
KM 52-198

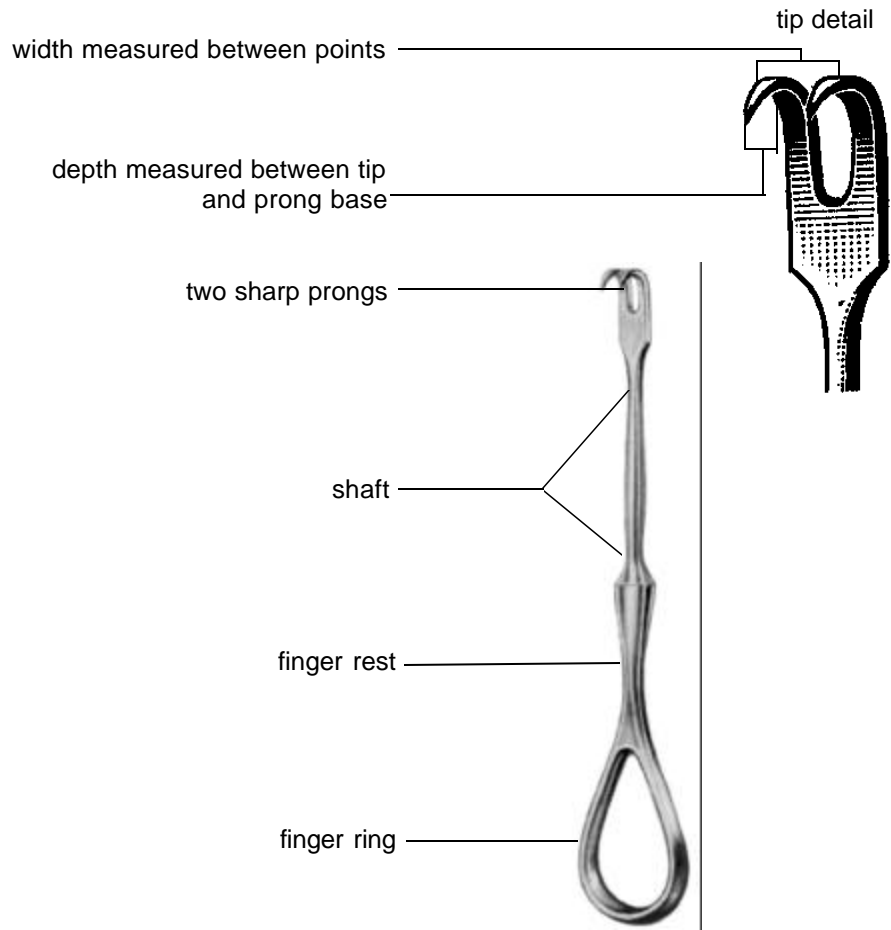

KMedic Product Information

Instrument type/name:	Retractors
Raw material:	Stainless steel Both hot-forged and cold-stamped blanks are used.
Surface:	Silk matte satin finish
Main function:	To retract, expose or hold back tissue, muscle, organs or bone for surgical exposure
Where used mostly:	General surgery Orthopedic surgery
Important product features:	There are generally two types of retractors: hand-held and self-retaining. As their names imply, the first type requires constant holding, while the self-retaining type can be inserted, set and left unattended for short periods of time.
Useful hints in usage:	The size and type of retractor chosen is determined by the task, including the depth of the incision. The smaller types are used generally on the surface to hold back skin and tissue, while the larger ones are designed to retract muscles, organs and bones in the deeper cavities of the body. To minimize trauma, the position of the retractor should be changed frequently during surgery.
Special care instructions:	
Instrument subtypes:	Skin Hooks Hand-Held Retractors including: -Finger Retractors -Shoulder Retractors -Knee Retractors -Rake Retractors -Hohmann Retractors -Malleable Retractors -Spinal Retractors

Retractors

Hohmann Retractor
KM 46-838

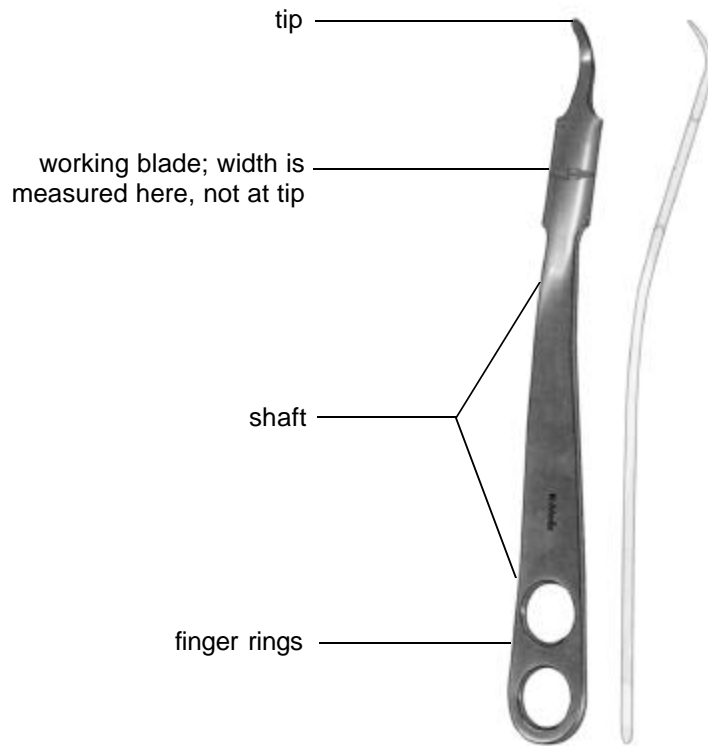

KMedic Product Information

Instrument type/name:	Hand-Held Retractors
Raw material:	Stainless steel Many from cold-forged or stamped blanks
Surface:	Silk matte satin finish
Main function:	To retract, expose or hold back tissue or expose bone
Where used mostly:	General surgery Orthopedic surgery Spinal surgery
Important product features:	Frequently produced with two working ends of different sizes. Some varieties have an ergonomic grip for secure handling. Some retractors are not tempered. This allows them to be shaped many times—according to the task at hand.
Useful hints in usage:	Hand-held retractors are often used in conjunction with self-retaining retractors.
Special care instructions:	
Other comments:	The most popular types are the Volkman and Hohmann.

Self-Retaining Retractor

Beckmann-Weitlaner Retractor
KM 52-530

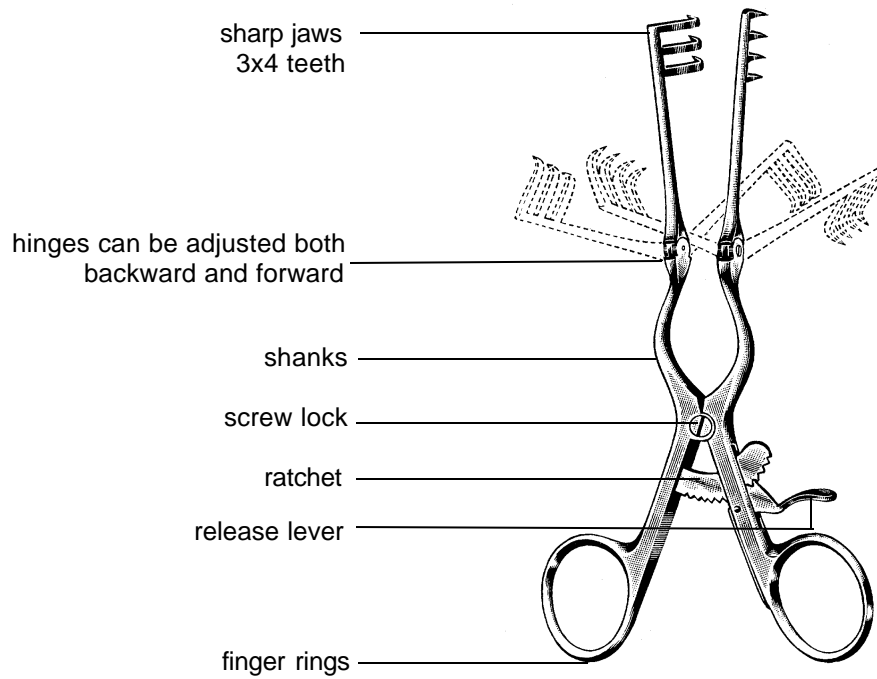

KMedic Product Information

Instrument type/name:	Self-Retaining Retractors
Raw material:	Forgings from stainless steel
Surface:	Silk matte satin finish
Main function:	To retract or hold back tissue or bone for surgical exposure
Where used mostly:	General surgery Orthopedic surgery Spinal surgery
Important product features:	They may be set in a fixed position with adjustable ratchet lock handles. They reduce slippage. Some variations have curved or hinged handles to minimize interference and maximize visibility.
Useful hints in usage:	
Special care instructions:	
Other comments:	The most popular types are the Gelpi 7 1/2", the Weitlaner 4" and 5 1/2", and the Inge 6 1/2".

Elevators

Periosteal Elevator
KM 46-217

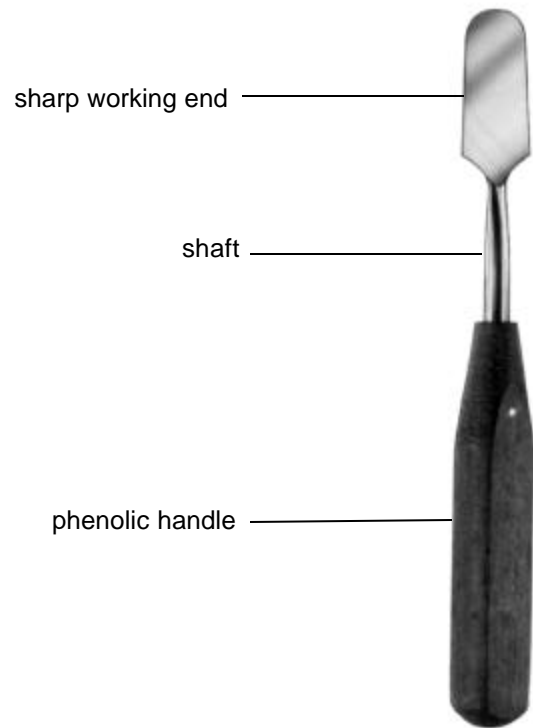

KMedic Product Information

Instrument type/name:	Elevators
Raw material:	Working ends: Forgings from stainless steel or bar stock Handles: Different shapes in: stainless steel phenolic anodized aluminum
Surface:	Silk matte satin finish
Main function:	To elevate and dissect bone, tissue, nerves. To clean and scrape bone. To expose fracture sites or bone in other procedures. Periosteal elevators are used to strip portions of the membrane (periosteum) covering the exterior surface of a bone.
Where used mostly:	Trauma, spinal and other bone and soft tissue procedures
Important product features:	They are well balanced to exert control. They have an ergonomic handle design. There is flexibility and firmness in the working end. They have a special hardness to maintain the edge on sharp types.
Useful hints in usage:	Select the proper size for the task.
Special care instructions:	Protect working ends and keep them sharp—damaged tips can harm the periosteum. Elevator sets are better protected when autoclaved, stored and used with KMedic SmartRacks™. See autoclave temperatures for phenolic handles.
Other comments:	The most popular types are the Freer KM 57-614 and Periosteal KM 46-211.
Instrument subtypes:	Elevators and Raspatories Periosteal Elevators, Spinal Elevators

Awls

Bone Awl
KM 48-336

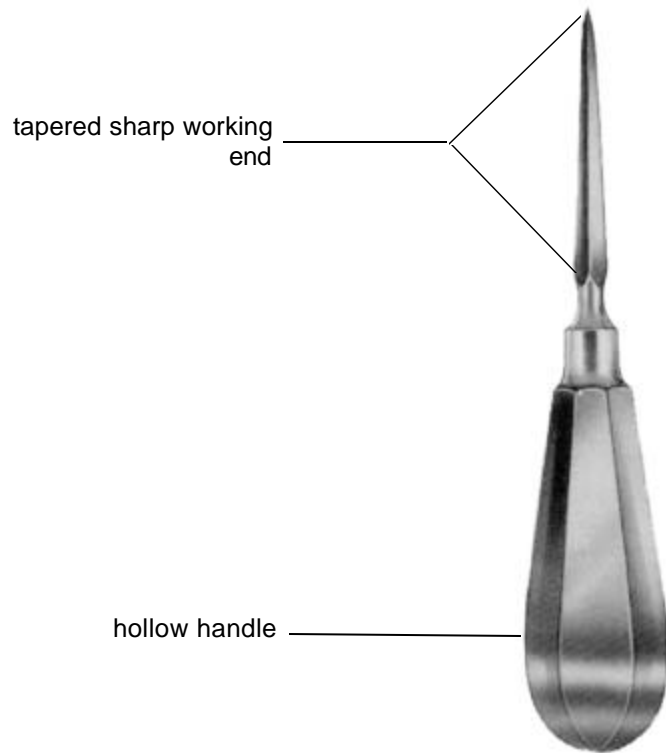

KMedic Product Information

Instrument type/name:	Awls
Raw material:	Forgings from stainless steel
Surface:	Silk matte satin finish
Main function:	To penetrate bone, open bone canals To direct pin insertions
Where used mostly:	Orthopedic surgery
Important product features:	
Useful hints in usage:	Great care must be taken to keep the awl from slipping off the bone and damaging soft tissue.
Special care instructions:	
Other comments:	
Instrument subtypes:	

Bone Hooks

Bone Hook
KM 48-343

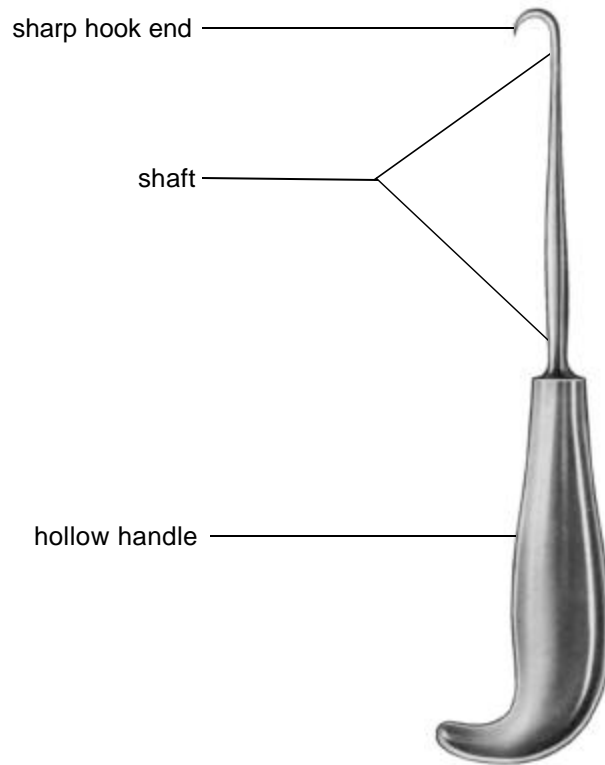

KMedic Product Information

Instrument type/name:	Bone Hooks
Raw material:	Forgings from stainless steel
Surface:	Silk matte satin finish
Main function:	To apply traction to reduce fractures in large bones
Where used mostly:	Orthopedic surgery (fractures)
Important product features:	
Useful hints in usage:	The large bone hook should be used when greater force is needed for reduction, e.g., in pelvic and femoral fractures.
Special care instructions:	
Other comments:	
Instrument subtypes:	

Bone Holding Instruments

Bone Reduction Forceps
KM 45-300

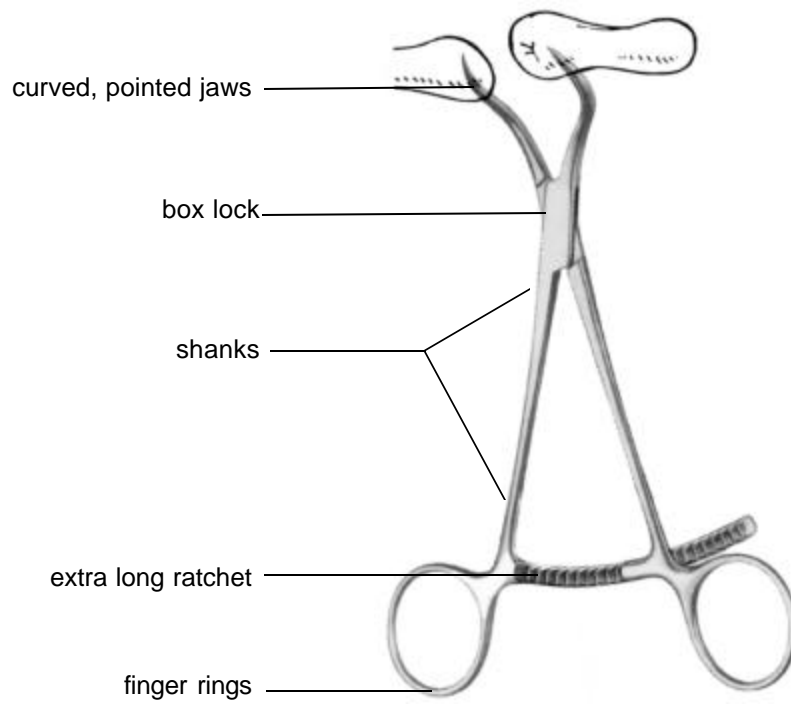

Bone Holding Instruments

Bone Reduction Forceps
KM 47-105

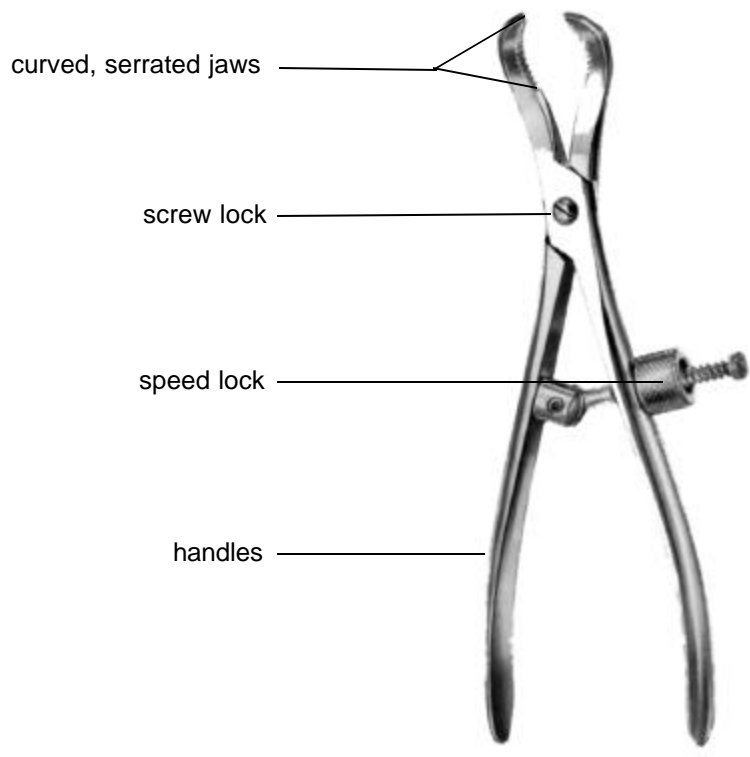

Bone Holding Instruments

Farabeuf-Lambotte Bone Holding
Forceps
KM 47-192

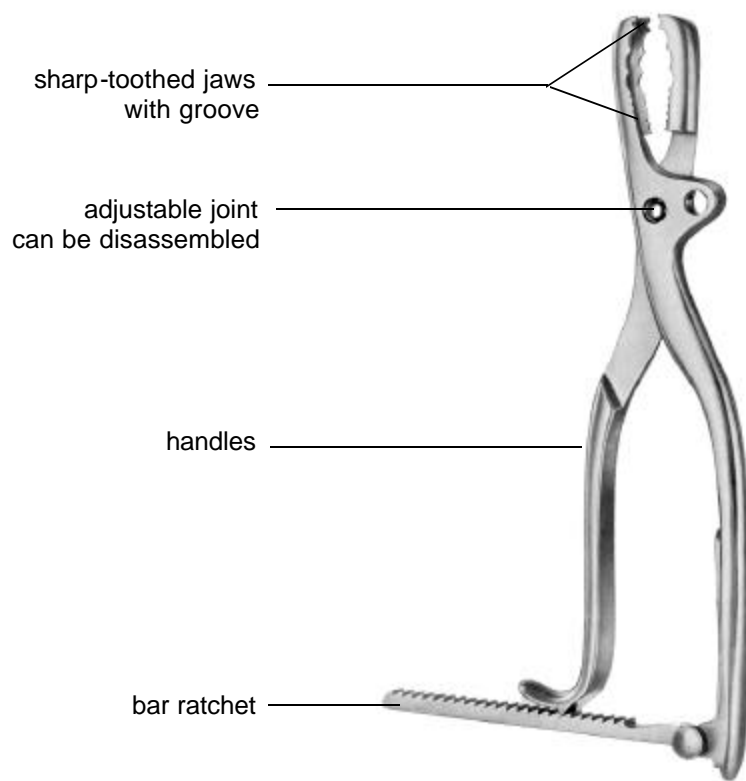

KMedic Product Information

Instrument type/name:	Bone Holding Forceps
Raw material:	Forgings from stainless steel
Surface:	Silk matte satin finish
Main function:	To hold, stabilize, rotate, reduce and compress bone To position bone screws and plates and insert K-Wire
Where used mostly:	Orthopedic surgery (fractures)
Important product features:	Some models come with a speed lock which can be easily operated with one hand. Some surgeons prefer the speed lock, while others prefer ratchets. Several models have adjustable jaws or hinges.
Useful hints in usage:	Narrow-jawed forceps will not compromise soft tissue and are best suited for hand and foot surgery. Broader-jawed instruments allow room for plate placement. To release the speed lock, squeeze the handles and turn the screw.
Special care instructions:	Select a forceps that corresponds to bone size—using an instrument which is too small or applying excessive force may damage the instrument.
Other comments:	The most popular models are KM 47-137, KM 47-105 and KM 47-062.
Instrument subtypes:	Forceps with Ratchet Forceps without Ratchet Forceps with Speed Lock Adjustable Forceps

Tendon Instruments

Caroll Tendon Pulling
Forceps
KM 46-740

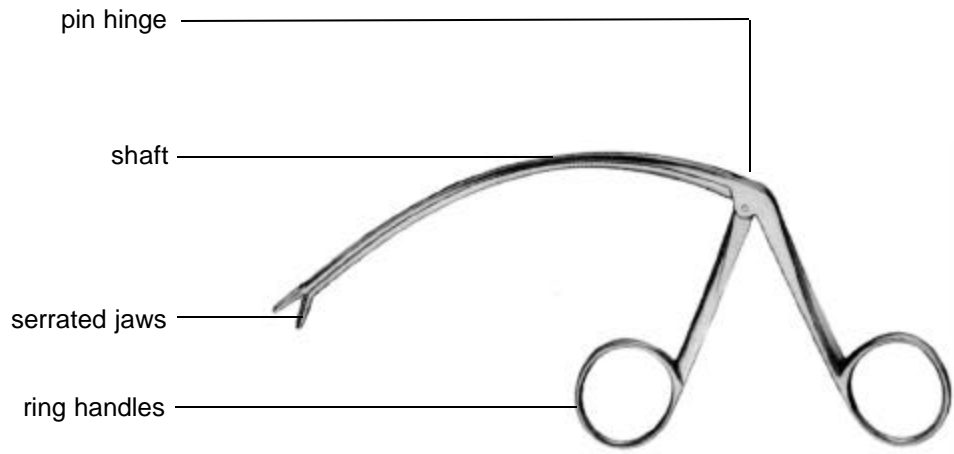

KMedic Product Information

Instrument type/name:	Cartilage and Tendon Instruments
Raw material:	Forgings from stainless steel
Surface:	Silk matte satin finish
Main function:	To retrieve, grasp, hold, cut and separate cartilage and tendons
Where used mostly:	Orthopedic surgery
Important product features:	There is a small array of instruments in this group, including scissors, forceps, clamps and knives.
Useful hints in usage:	These instruments are used in reattaching or repairing torn cartilage and tendons.
Special care instructions:	
Other comments:	
Instrument subtypes:	

Curettes

Brun (Spratt) Curette
KM 46-511

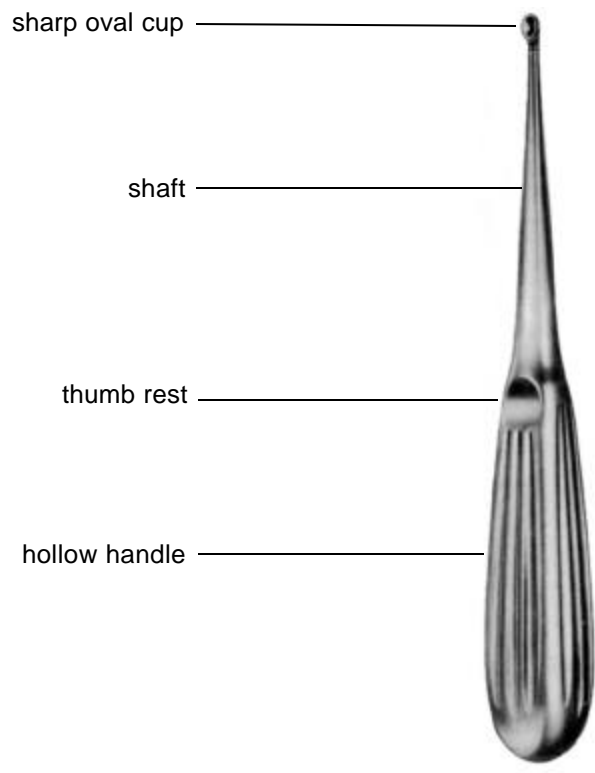

KMedic Product Information

Instrument type/name:	Bone Curettes
Raw material:	Working ends: Forgings from stainless steel Handles: Solid or hollow stainless steel or anodized aluminum
Surface:	Silk matte satin finish
Main function:	To scrape, shape and clean bone
Where used mostly:	Orthopedic surgery
Important product features:	Most curettes come with a round or oval, closed-cup design. They are available in straight, curved or angled designs. Some curettes come with an open-cup design (Ring Curettes), e.g., Ray and Cone Curettes.
Useful hints in usage:	Keep the working end sharp.
Special care instructions:	Sharp ends are better protected when autoclaved, stored and used with KMedic SmartRacks™. SmartRacks are available for Brun and Cobb models.
Other comments:	The most popular types are the Brun 7" and 9" oval.
Instrument subtypes:	

Osteotomes, Chisels and Gouges

Hibbs Osteotome
KM 46-359

tip details: osteotome chisel gouge

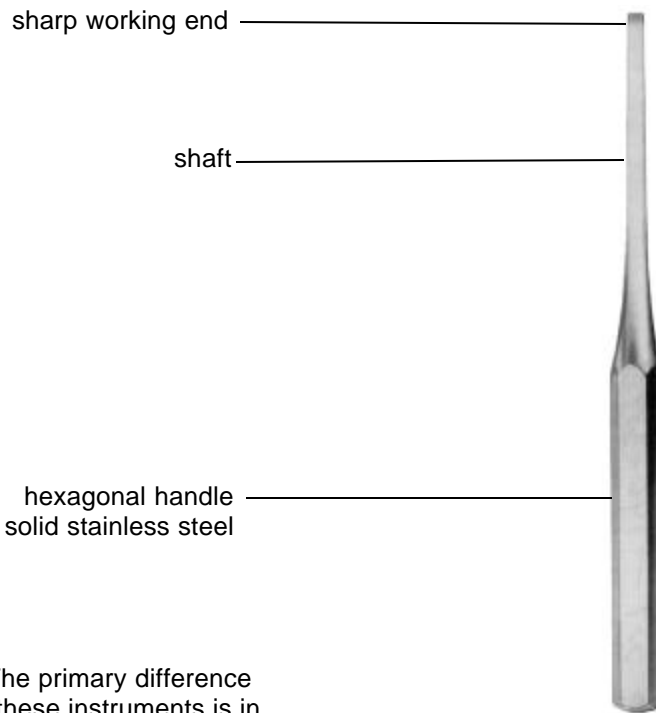

NOTE: The primary difference between these instruments is in the tips—see the above tip details to distinguish the types.

KMedic Product Information

Instrument type/name:	Osteotomes, Chisels and Gouges
Raw material:	Working ends: Forgings from stainless steel Handles: Stainless steel and phenolic
Surface:	Silk matte satin finish
Main function:	To score, cut, scrape, clean and sculpt bone Osteotomes: To shape and sculpt bone, particularly cancellous Chisels: To cut a window in the bone cortex to allow harvesting of pure soft bone Gouges: To scoop away strips of soft bone, especially in bone grafting
Where used mostly:	Orthopedic surgery, especially bone grafting (harvesting)
Important product features:	Osteotomes have a working end without a bevel; the smaller versions are suitable for hand surgery. They are frequently used for cancellous bone. Chisels have a working end with a bevel. Osteotomes, chisels and gouges are designed for use with a mallet. They are available in straight and curved models.
Useful hints in usage:	Bending forces should not be applied to chisel blades. Removable blades should be discarded after use, e.g., KM 49-630. Great care must be taken to select the proper size, bevel type and force to avoid splitting bone.
Special care instructions:	Sharp ends are better protected when autoclaved, stored and used with KMedic SmartRacks™. SmartRacks are available for Lambotte, Hoke and Hibbs osteotomes, Hibbs chisels, Hibbs and Cobb-type gouges
Other comments:	The most popular types are the Lambotte, Hoke and Hibbs.
Instrument subtypes:	

Mallets

Reprocussion Free Mallet
KM 46-690



KMedic Product Information

Instrument type/name:	Bone Mallets
Raw material:	Working ends: Solid, lead filled or brass filled with stainless steel mantle, or solid stainless steel. Some mallet heads with nylon caps. Handles: phenolic, anodized aluminum or stainless steel
Surface:	Silk matte satin finish
Main function:	To exert force on osteotomes, chisels, gouges, etc. To drive the instruments for inserting nails into the medullary canal.
Where used mostly:	Orthopedic surgery, particularly bone grafting (harvesting)
Important product features:	Phenolic handles are grooved for a better and more comfortable grip.
Useful hints in usage:	Repercussion can be a problem, especially when using a heavy mallet to strike metal objects. In these cases, use the repercussion free (dead blow) mallet (KM 46-690). Select the proper mallet size—failure to do so may cause the separation of handle and head or breakage of head.
Special care instructions:	See specific instruments for autoclaving temperatures. Lead-filled mallets are for use on flat surfaces only, as the lead may otherwise flake. Brass-filled mallets are for use on flat surfaces only.
Other comments:	The nylon caps may be replaced. The most popular mallets are KM 46-662, KM 46-666, and KM 46-667.
Instrument subtypes:	

Tamps

Bone Tamp
KM 46-896

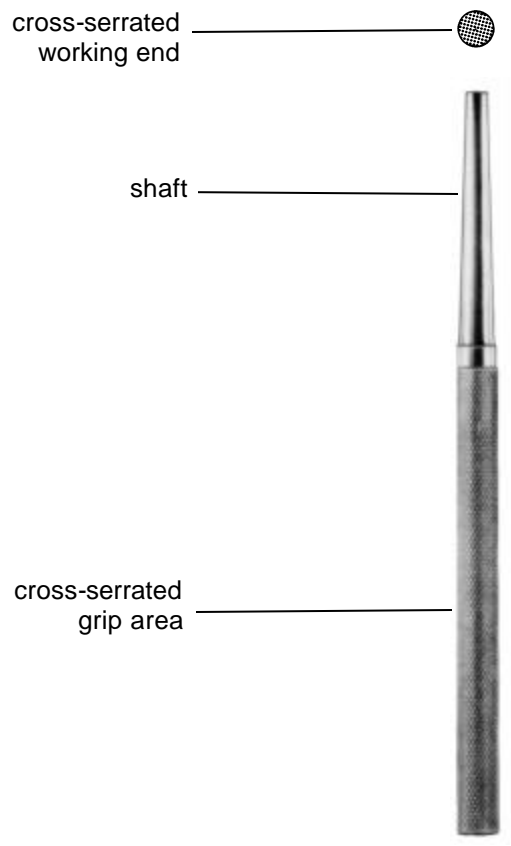

KMedic Product Information

Instrument type/name:	Tamps
Raw material:	Forgings from stainless steel
Surface:	Silk matte satin finish
Main function:	To wedge bone graft into place
Where used mostly:	Orthopedic surgery (bone grafting)
Important product features:	Tamps have a conical working end and cross-serrated tip. They are available in a number of sizes (diameters).
Useful hints in usage:	
Special care instructions:	
Other comments:	
Instrument subtypes:	

Bone Files and Rasps

Foman Rasp, double-ended
KM 46-655

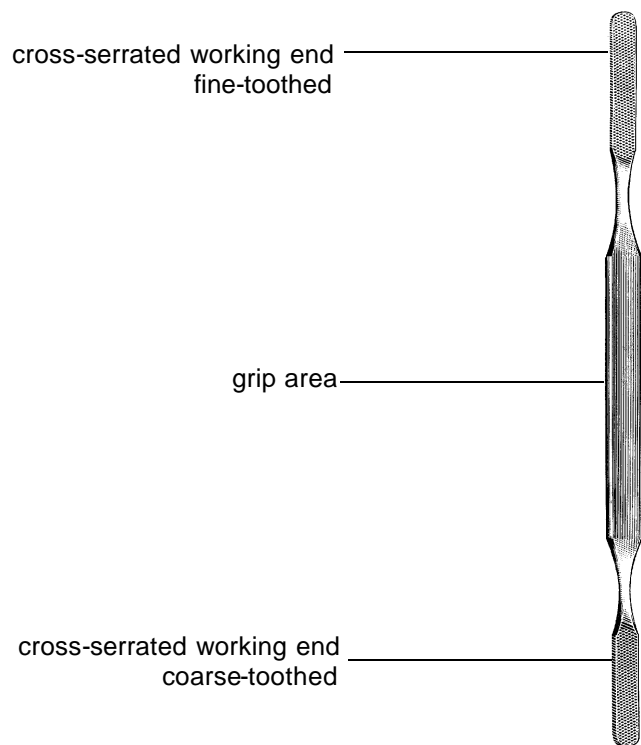

KMedic Product Information

Instrument type/name:	Bone Files and Rasps
Raw material:	Forgings or bar stock from stainless steel
Surface:	Silk matte satin finish
Main function:	To smooth, sculpt and clean bone
Where used mostly:	Orthopedic surgery, including bone grafting
Important product features:	A variety of sizes and styles—fine to coarse—is available. Some models have two working ends of the same or variable sizes. Other models have a single working end with a more easily grasped handle. Several files and rasps have forward and/or backward cutting teeth. Forward-cutting teeth are pointed upwards. Backward-cutting teeth are pointed downwards.
Useful hints in usage:	
Special care instructions:	Use soft brushes (KM 39-682 or KM 39-384) to clean out grooves and serrations for effective cutting action and cleaning.
Other comments:	The most popular types are the Fomon KM 46-655 and Putti KM 46-654.
Instrument subtypes:	

Bone Cutters

Liston Bone Forceps
KM 47-398

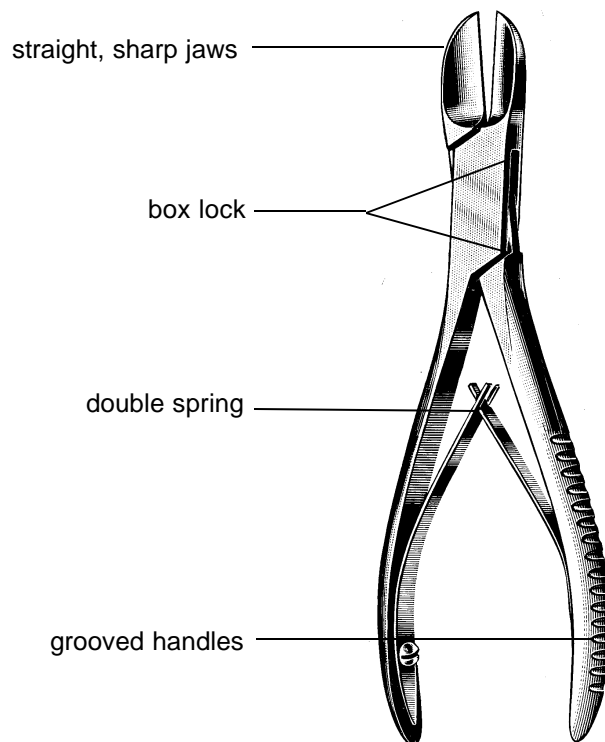

Bone Cutters

Ruskin-Liston Forceps
KM 47-550

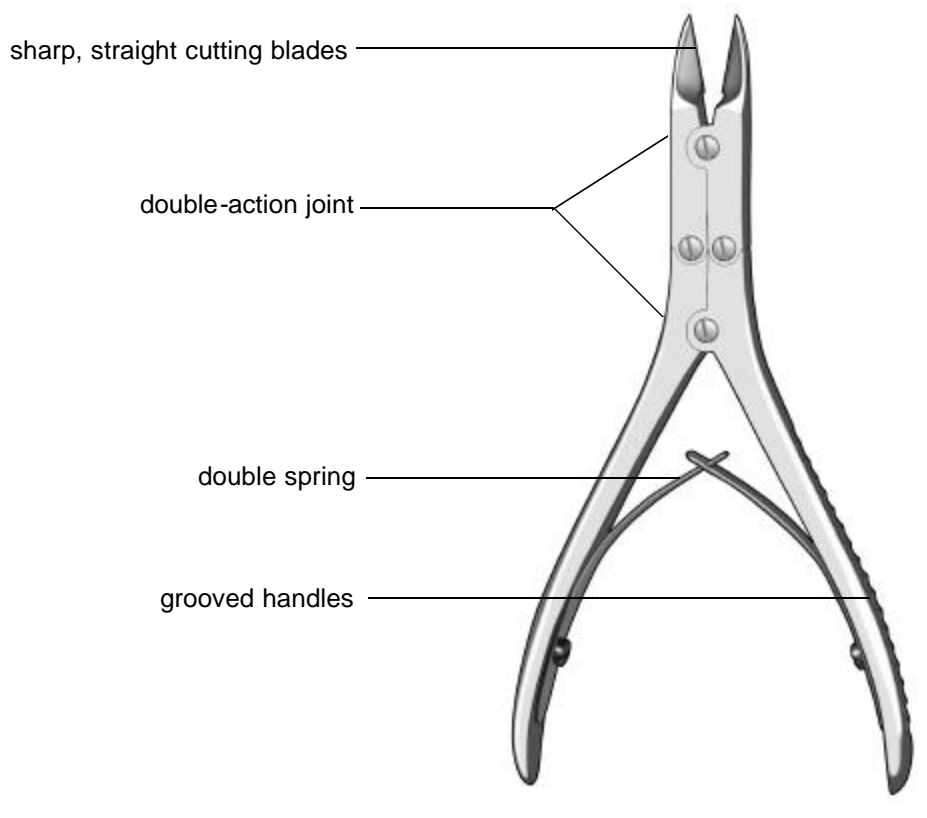

Trephines

Michele Trephine
KM 48-240

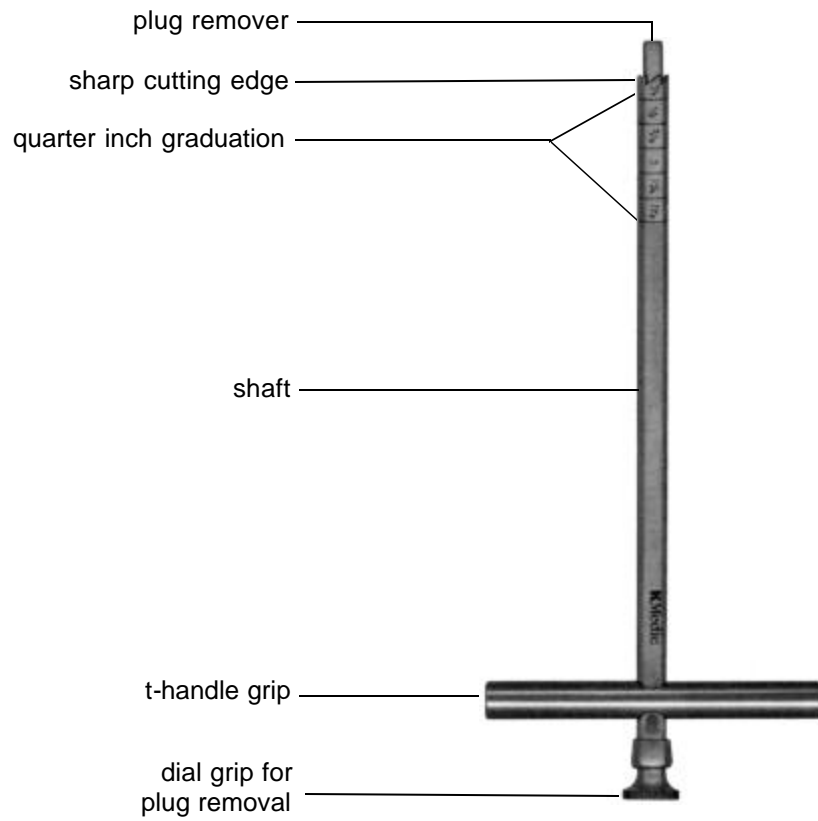

Bone Rongeurs

Ruskin Rongeur
KM 47-527

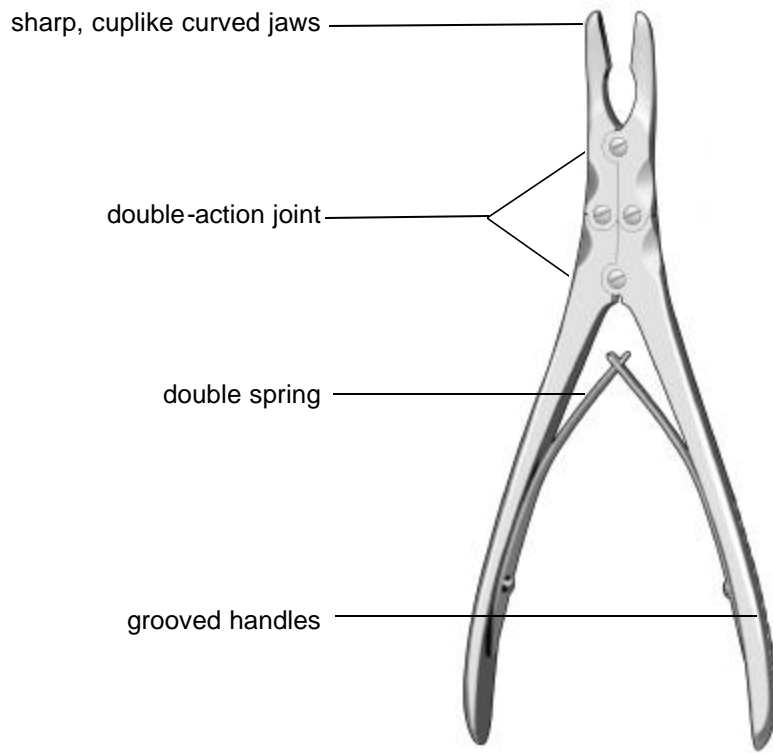

Bone Rongeurs

Leksell Rongeur
KM 47-486

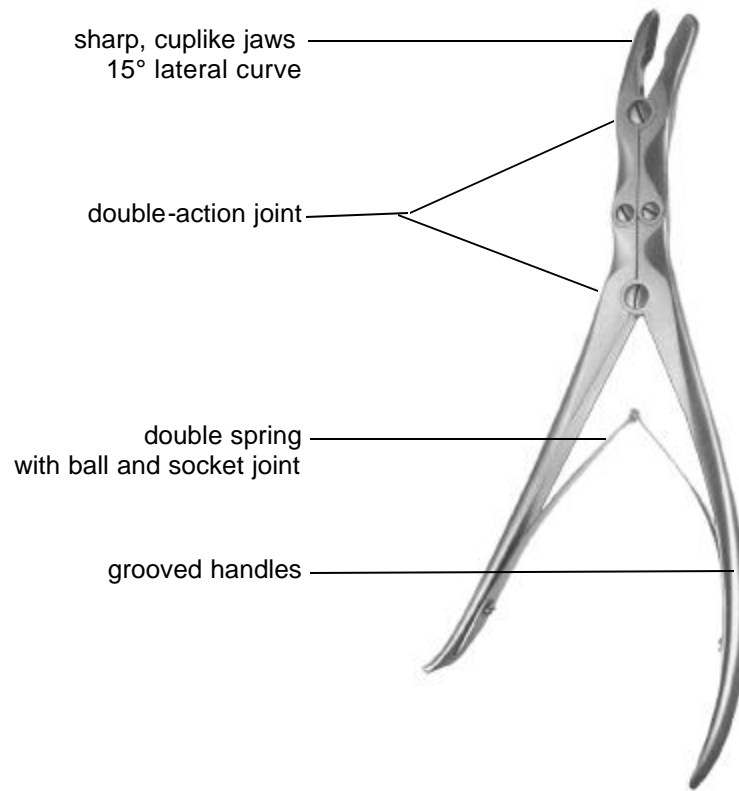

KMedic Product Information

Instrument type/name:	Bone Cutters, Trephines and Bone Rongeurs
Raw material:	Forgings from stainless steel
Surface:	Silk matte satin finish
Main function:	To excise, trim and sculpt soft (cancellous) or hard (cortical) bone. Bone Cutters: To cut bone or to remove bone splinters. Trephines: For bone biopsy and also used to remove broken screws. Rongeurs: To cut or remove small pieces of tissue or bone.
Where used mostly:	Orthopedic surgery
Important product features:	A variety of styles and sizes is available, in straight and curved patterns, with a single-action or double-action joint. The double-action models provide much more power to the surgeon, causing less hand fatigue—they are also more expensive. Rongeurs are characterized by a hollowed, cup-like working end, while cutting forceps have beveled, scissor like cutting edges.
Useful hints in usage:	Certain rongeurs are designed for use on soft tissue and cancellous bone only.
Special care instructions:	Select the proper size to perform the task. Take care not to cut implants, this will ruin cutting edge.
Other comments:	The most popular types are the Liston, Ruskin-Liston, Ruskin, Beyer and Leksell.
Instrument subtypes:	

Bone Saws

Gigli Saw Handle, loop style
KM 46-616

Gigli Saw Blade
KM 46-612

Gigli saw blade



loop-style Gigli saw handle
used in pairs
with a Gigli saw blade
(pictured above)

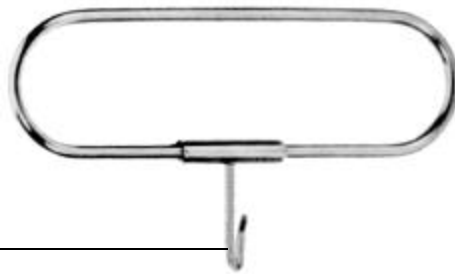

working end used to hold blade

KMedic Product Information

Instrument type/name:	Bone Saws and Bone Knives
Raw material:	Forgings from stainless steel or chrome plated
Surface:	Silk matte satin finish or chrome plating
Main function:	To cut bone, e.g., in amputations
Where used mostly:	Orthopedic surgery
Important product features:	Saws such as the Satterlee can be disassembled; the blade can be removed when dulled. Gigli handles are used with Gigli saw blades, which should be disposed of after use.
Useful hints in usage:	
Special care instructions:	
Other comments:	The most popular types are the Satterlee and Gigli.
Instrument subtypes:	

Spinal Rongeurs

Ferris-Smith-Kerrison
Laminectomy Rongeur
KM 47-990

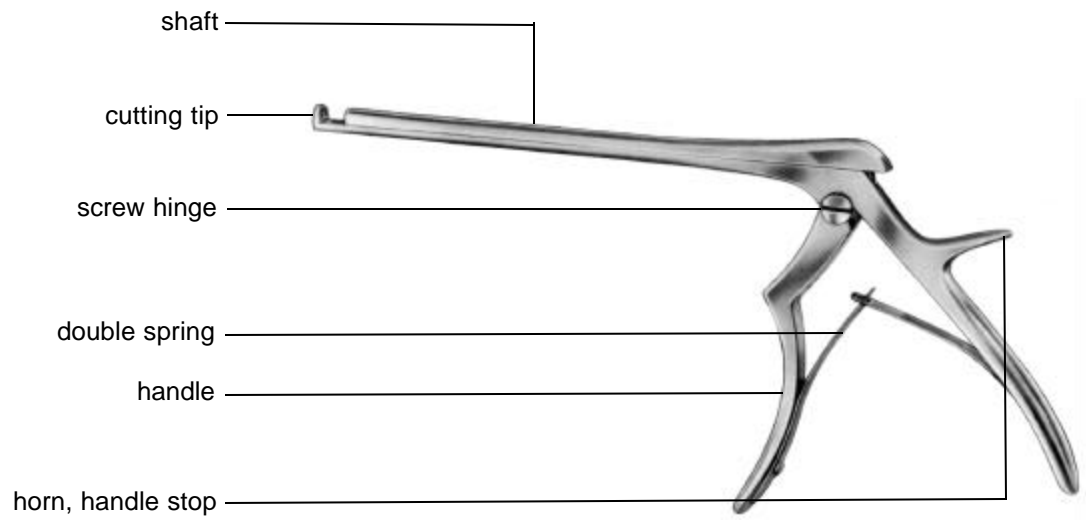

Spinal Rongeur Jaw Types

bite styles
punch jaws

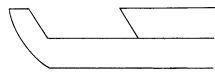

forward 40°

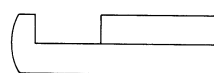

up 90°

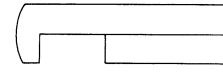

down 90°

bite styles
cup jaws



straight



up



down

punch jaws

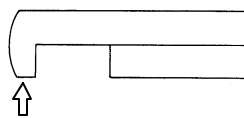

foot plate

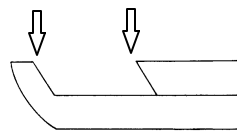

bite opening



bite

Spinal Rongeur Handles

style I
ring



style II
kerrison



style III
love-kerrison



Spinal Rongeur Handles

style IV
improved
love-kerrison



style V
ferris-smith
kerrison



style VI
ferris-smith
kerrison ring



KMedic Product Information

Instrument type/name:	Spinal Rongeurs (Neurorongeurs)
aka:	Spinal-Orthopedic Rongeurs, Punches
Raw material:	Forgings from stainless steel
Surface:	Silk matte satin finish
Main function:	To grasp or excise tissue, degenerated disc material or bone during spinal and neurological procedures.
Where used mostly:	Spinal surgery and neurosurgery
Important product features:	A variety of styles and sizes are available. Working ends generally come in a punch style or rongeur (cup) style, with different bite sizes and different angles. The working end is measured from the tip to the hinge. Most rongeurs can be custom made with a choice of handles, jaw width, bite size and style, and length of shaft. Some handles are specially designed to reduce slippage. Other handles are specially designed to accommodate smaller hands.
Useful hints in usage:	Avoid hitting implants when cutting, as this will ruin the cutting edge. Avoid overloading the cutting edge, since this can lead to breakage. Resharpen rongeurs to maintain peak efficiency.
Special care instructions:	
Other comments:	The most popular types are the Love-Kerrison and Ferris-Smith-Kerrison.
Instrument subtypes:	Intervertebral Disc Rongeurs Laminectomy Rongeurs Cervical Rongeurs

Plaster Cast Instruments

KMedic Cast Spreader (Walton)
KM 46-134

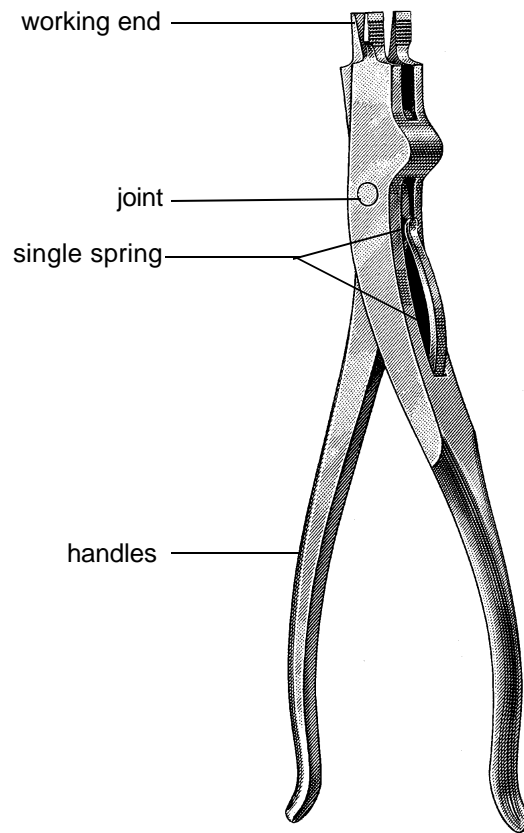

KMedic Product Information

Instrument type/name:	Plaster Cast Instruments
Raw material:	Forgings from stainless steel
Surface:	Silk matte satin finish
Main function:	To cut or break bandages, stockinette, drapes, felt, fiberglass, plaster aluminum and other cast materials
Where used mostly:	Casting room
Important product features:	
Useful hints in usage:	Choose the appropriate instrument to cut or remove material.
Special care instructions:	
Other comments:	The most popular model is KM 46-134.
Instrument subtypes:	

Wire and Pin Implants

tip details for
K-Wire (Kirschner Wire)
KM 71-021-KM 71-313

Kirschner Wires, smooth

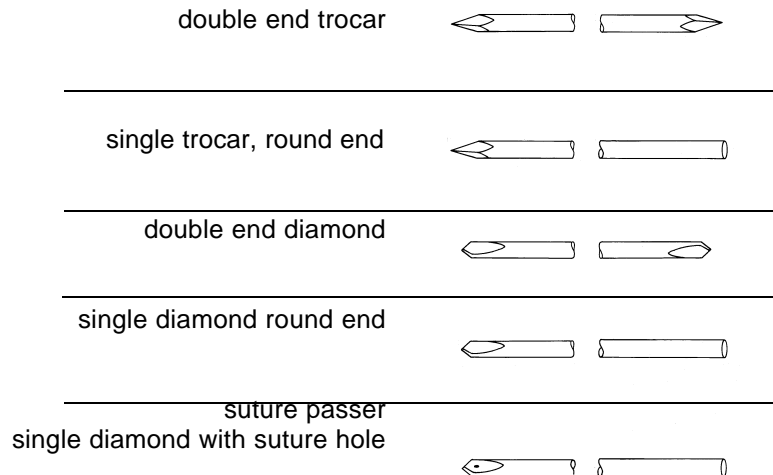

Kirschner Wire, fully threaded

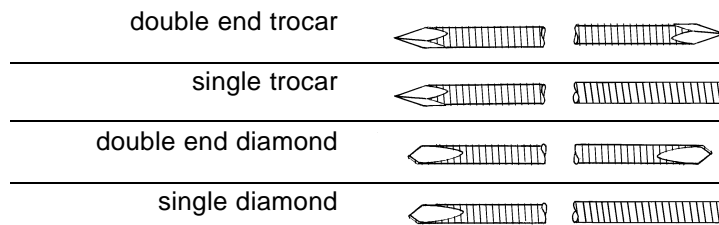

Wire and Pin Implants

tip details for
Steinmann Pins
KM 71-450- KM 71-898

Steinmann Pins, smooth

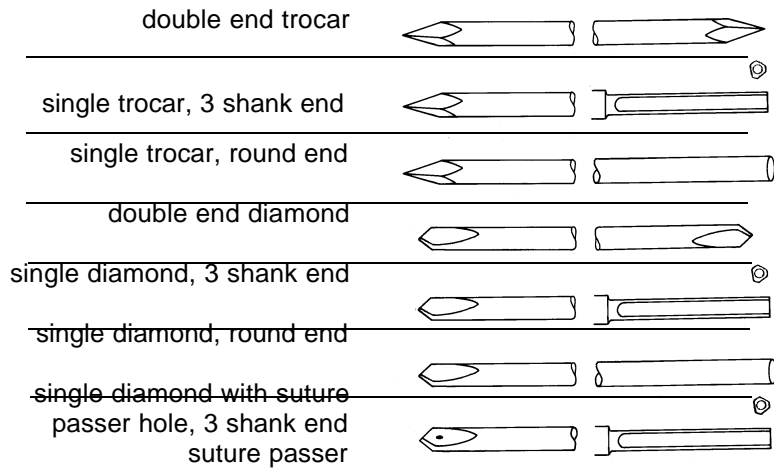

Steinmann Pins, fully threaded

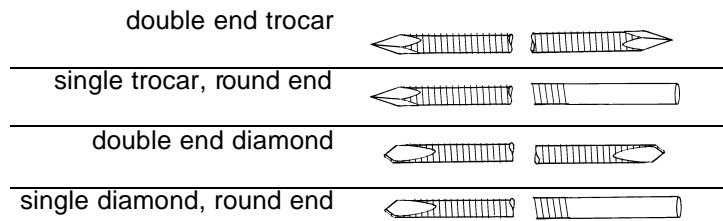

KMedic Product Information

Instrument type/name:	Wire and Pin Implants
Raw material:	Implant stainless steel
Surface:	Hand-polished satin finish
Main function:	To aid in alignment, reduction and internal and external fixation of fractured bone
Where used mostly:	Orthopedic surgery (fractures)
Important product features:	They have long, gently tapered points for easier penetration. They are smoothly hand polished, causing less trauma when removed. They are sold in packages of six. Pins are smooth, partially threaded or fully threaded and have tips of varying angles. A trocar tip has three sides. A diamond tip has two sides.
Useful hints in usage:	An internal fixation device must never be reused.
Special care instructions:	
Other comments:	The most popular models are KM 71-103 and KM 71-113.
Instrument subtypes:	Kirschner Wires (aka K-Wires) Steinmann Pins Guide Wires Schanz Pins Cerclage Wire

Pin Cutters

Large Pin Cutter
KM 46-626

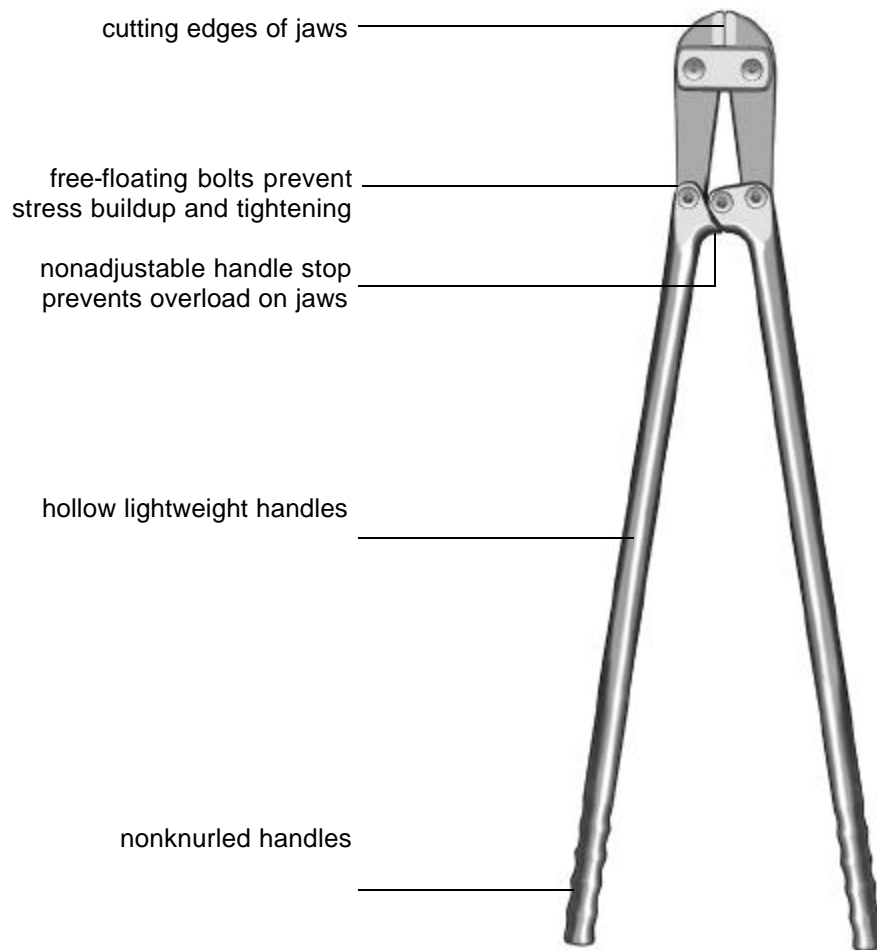

KMedic Product Information

Instrument type/name:	Wire and Pin Cutters
Raw material:	Forgings from stainless steel Reinforced with jaw inserts from tungsten carbide or specially tempered tool steel
Surface:	Silk matte satin finish or sand-blasted satin finish
Main function:	To cut wires and pins
Where used mostly:	Orthopedic surgery (fractures)
Important product features:	A variety of end and side cutters are available for different wire diameters and different cutting angles. Double-action handles provide more cutting power and help absorb the shock of wire cutting, enabling better control with less fatigue. Carbide inserts may be replaced, extending the instrument's life and value. Welded carbide jaws cannot be replaced.
Useful hints in usage:	Choose the appropriate cutter for the wire diameter being cut. Maximum cutting capacities are marked on each cutter and should not be surpassed. Cut in the center of edge, avoid cutting on ends of cutting edge. When cutting, protect from flying particles.
Special care instructions:	
Other comments:	
Instrument subtypes:	Cable Cutters

**Wire and Pin Management
Instruments**

Heavy Duty Locking Pliers
KM 48-600

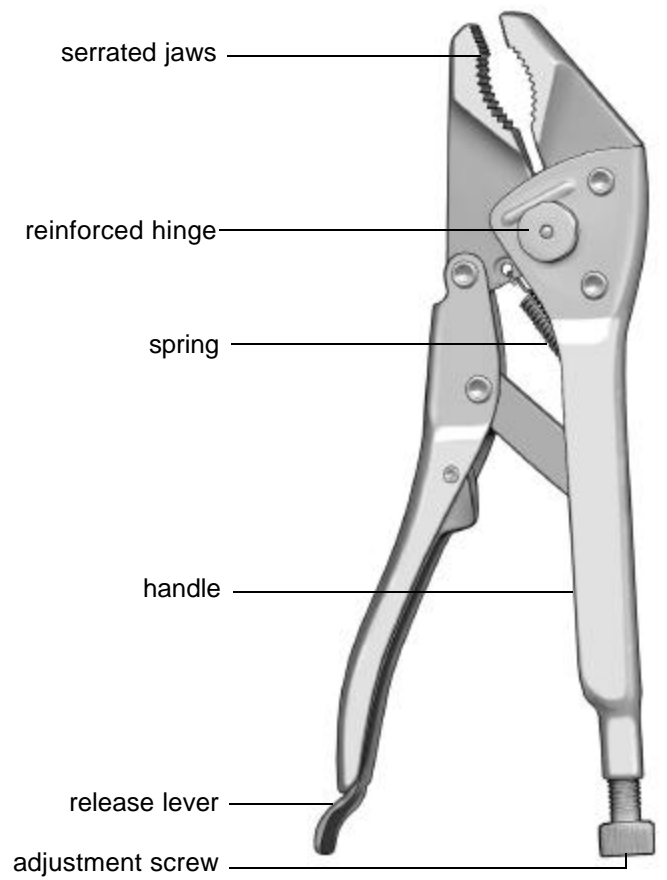

KMedic Product Information

Instrument type/name:	Wire and Pin Management Instruments	
Raw material:	Forgings from stainless steel	
Surface:	Silk matte satin finish	
Main function:	To assist the surgeon in the implantation and removal of pins and wires. To store, pull, twist, cut and tighten wires, pins and rods.	
Where used mostly:	Orthopedic surgery (fractures)	
Important product features:	Since many detailed functions are described in the KMedic Orthopedic Sourcebook, refer to section Q for this information, especially "About KMedic Wire and Pin Cutters" and "About KMedic Pliers".	
Useful hints in usage:		
Special care instructions:		
Other comments:	The most popular models are KM 48-245, KM 48-246, KM 48-262 and KM 48-602.	
Instrument subtypes:	K-Wire Dispensers Wire Drivers and Benders Hand Drills Chucks Wire and Pin Cutters Cable Cutters	Plate Cutters Pliers Plug Cutters Wire Twisters Wire Tighteners Wire Guides

Hand Drills

Ralks Drill
KM 48-390

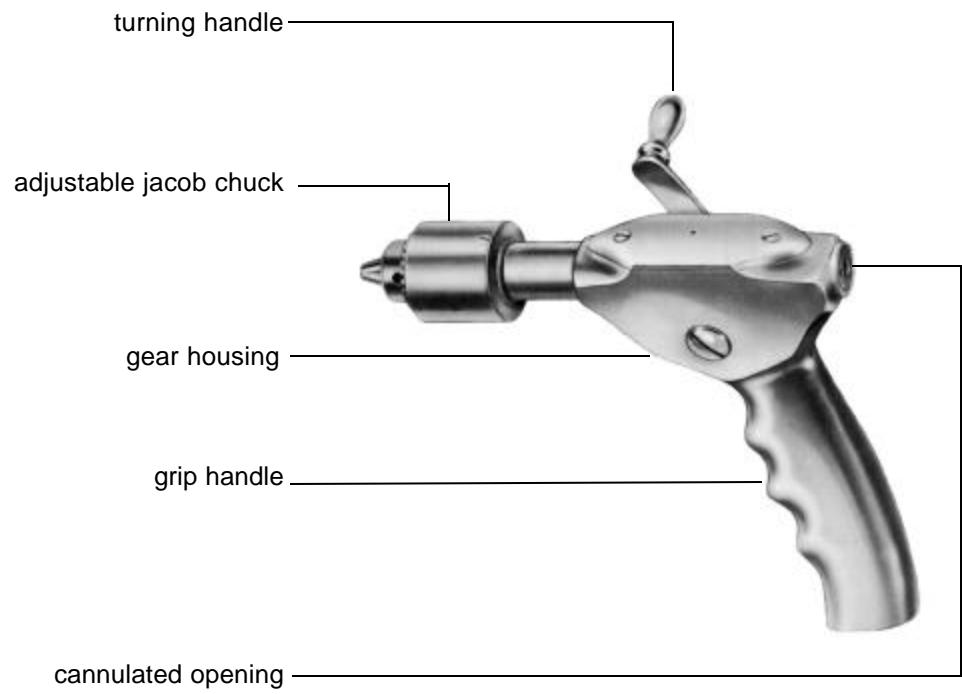

KMedic Product Information

Instrument type/name:	Hand Drills
Raw material:	Chuck: stainless steel Body: aluminum or chrome-plated Gear: chrome-plated or stainless steel Handle: stainless steel or aluminum
Surface:	Silk matte satin finish and chrome
Main function:	To insert K-Wires, guide wires, Steinmann pins and rods
Where used mostly:	Orthopedic surgery (fractures), neurosurgery
Important product features:	A variety of styles are available. Some styles have specially designed handles for optimal control.
Useful hints in usage:	They are used as an alternative to power drills.
Special care instructions:	Lubricate moving parts.
Other comments:	
Instrument subtypes:	

Bone Screws

Cortical Screw
KM 73-840

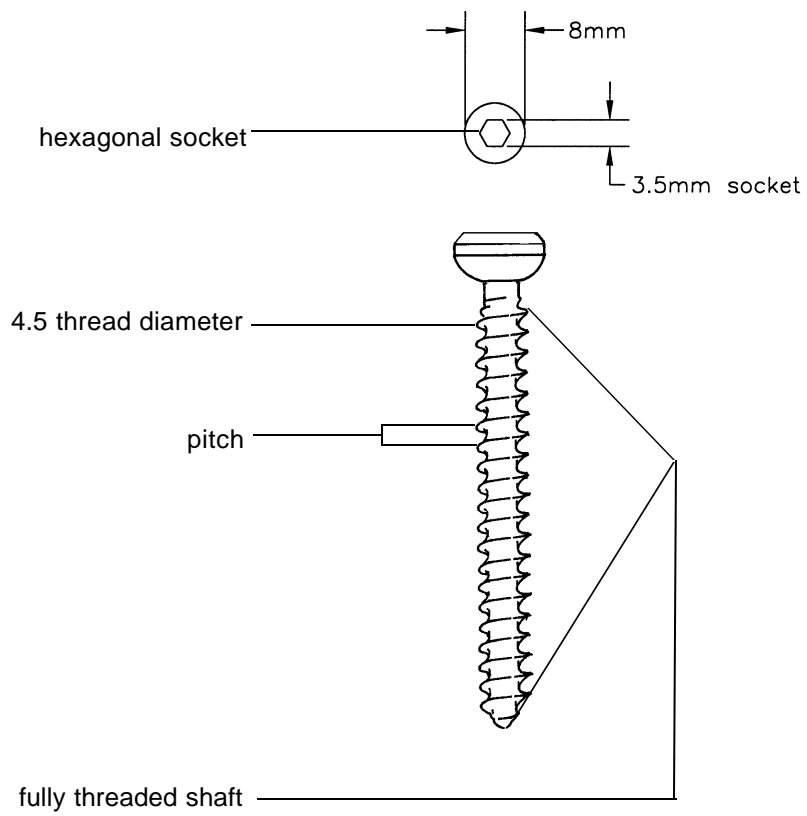

Note: screw has been enlarged to show detail

KMedic Product Information

Instrument type/name:	Bone Screws
Raw material:	Bar stock certified implant stainless steel
Note:	For complete information on the entire Fracture Fixation system please consult the book <i>AO/ASIF Instruments and Implants</i> (Texhammer/Colton Springer Publishers).
Main function:	To fasten together fractured bone segments and to affix bone plates.
Where used mostly:	Orthopedic surgery (fractures)
Important product features:	Screws come in various sizes and types, and are designed for bones of different size, type and quality.
Useful hints in usage:	Screw sizes are determined by the outside diameter of their threaded section. It is very important to chose the proper type of screw for the procedure. Screws are not self-tapping and require that a thread be cut before insertion. Washers are available to prevent screw heads from sinking into bone. An internal fixation device should never be reused.
Special care instructions:	
Other comments:	
Instrument subtypes:	Cortical Bone Screws Cancellous Bone Screws Malleolar Bone Screws

Bone Plates

Narrow Compression Plate
KM 76-026

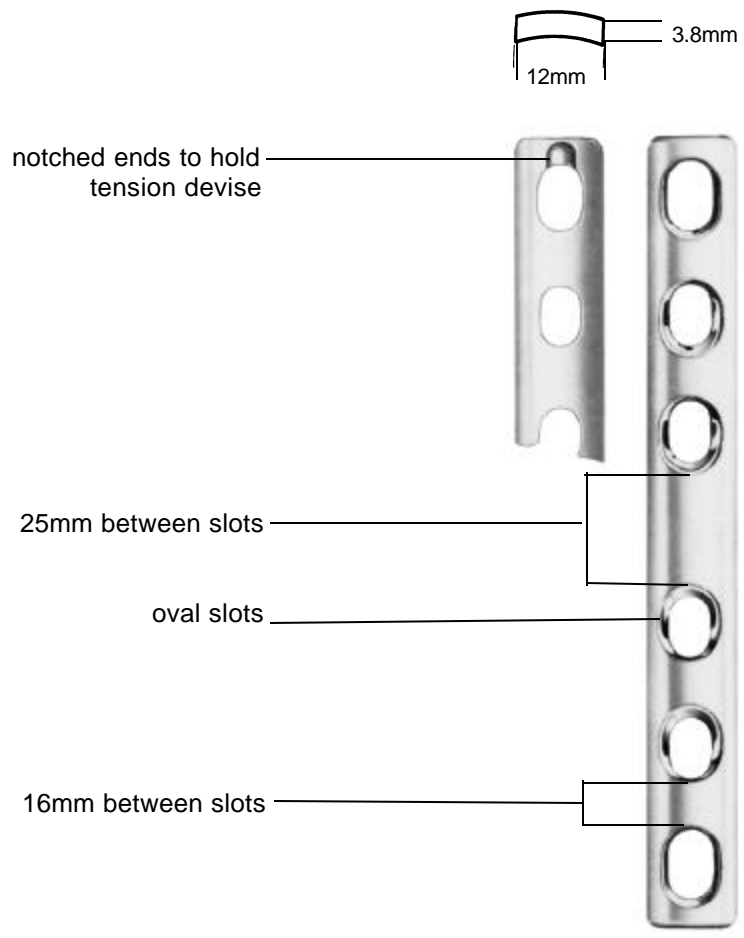

KMedic Product Information

Instrument type/name:	Bone Plates
Raw material:	Bar stock certified implant stainless steel
Note:	For complete information on the entire Fracture Fixation system please consult the book <i>AO/ASIF Instruments and Implants</i> (Texhammer/Colton Springer Publishers).
Main function:	To fasten together fractured bone segments
Where used mostly:	Orthopedic surgery (fractures)
Important product features:	Plates come in various sizes and types, designed for bones of different size, type and quality, and require a variety of screw sizes.
Useful hints in usage:	Plate names generally derive from the plate design or bone for which it is designed. Plate holes are designed to allow screw insertions at varying angles. An internal fixation device should never be reused.
Special care instructions:	
Other comments:	
Instrument subtypes:	

Drill Bits

Drill Bit, with quick-coupling end
KM 48-051

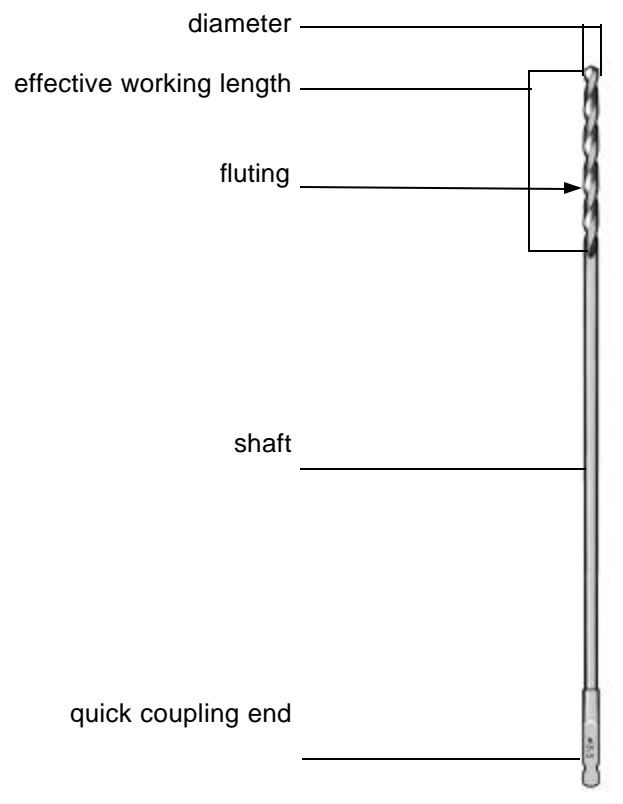

KMedic Product Information

Instrument type/name:	Drill Bits
Raw material:	Bar stock from stainless steel
Surface:	Sand-blasted satin finish
Main function:	To drill gliding and threaded holes. To place bone screws and plates during internal fracture fixation.
Where used mostly:	Orthopedic surgery (fractures)
Important product features:	Drill bits are available in a variety of sizes and styles. There are two types of ends—QC type to fit a QC handle, and round end to fit a Jacobs chuck. Some bits are calibrated to check drill depth.
Useful hints in usage:	It is very important to choose the proper bit size for the bone screw selected. Drill bits should be disposed of after one use. Dull drill bits can lead to necrosis and make it very difficult for the surgeon to achieve accuracy.
Special care instructions:	
Other comments:	Custom diameters and lengths can be manufactured on special order. Cannulated drill bits are also available by special order.
Instrument subtypes:	

Countersinks

Small Countersink
KM 47-922

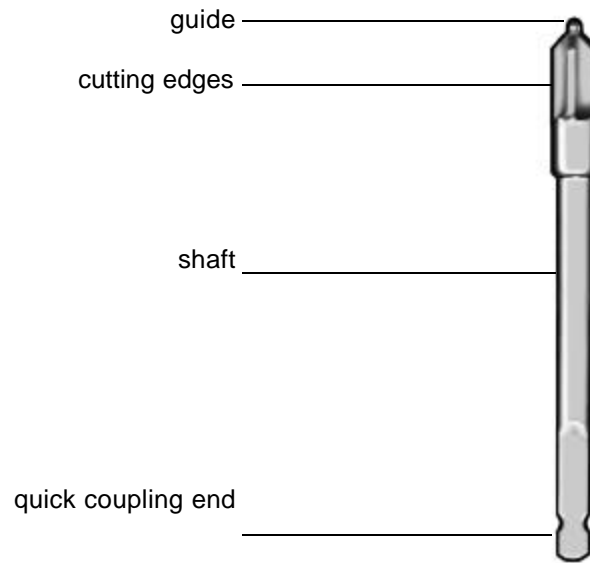

KMedic Product Information

Instrument type/name:	Countersinks
Raw material:	Bar stock from stainless steel
Surface:	Sand-blasted satin finish
Main function:	To prepare recess in bone for a screw head
Where used mostly:	Orthopedic surgery (fractures)
Important product features:	Countersinks are available in a number of sizes, to correspond to varying screw sizes. Countersinking reduces the concentration of stress caused by the screw head on the bone.
Useful hints in usage:	Countersinking should be performed before a depth gauge is used. Select the correct size.
Special care instructions:	
Other comments:	
Instrument subtypes:	

Taps

Tap for Cortical Screws
KM 48-112

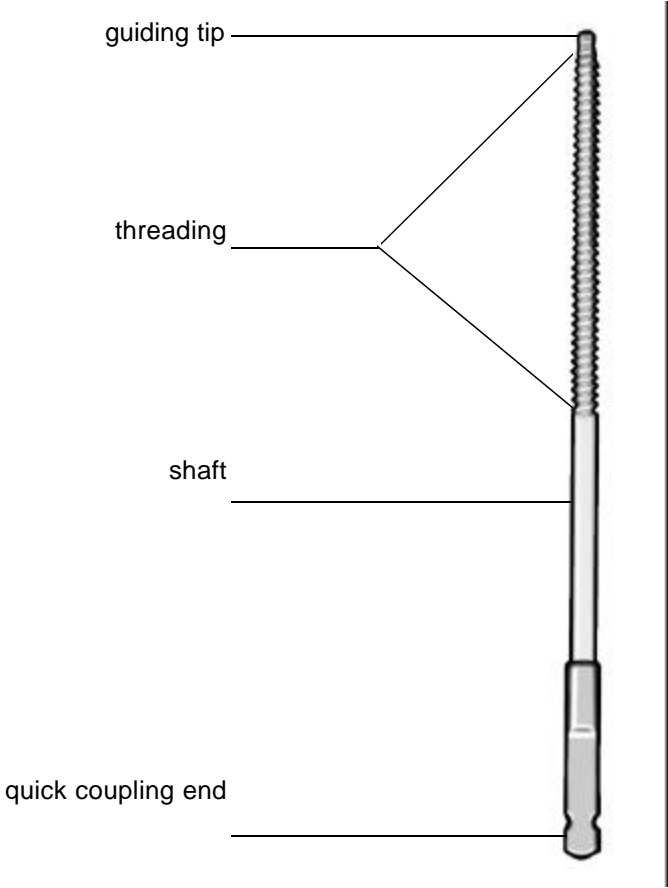

KMedic Product Information

Instrument type/name:	Taps
Raw material:	Bar stock stainless steel
Main function:	To prepare thread path for insertion of bone screws
Where used mostly:	Orthopedic surgery (fractures)
Important product features:	Taps are available in a variety of sizes and shapes to correspond to different screw sizes. Taps have special flutes for clearing bone debris. Taps have quick-coupling ends.
Useful hints in usage:	Tapping should be performed manually. The tap should be cleared of bone debris after each use. The tap thread size should match the screw thread size. Tapping should be performed after countersinking and measuring. Used taps should be discarded after each procedure—they are easily dulled and might otherwise damage the drilled tunnel.
Special care instructions:	
Other comments:	
Instrument subtypes:	

Quick Coupling Handles

Small Quick Coupling Handle
KM 47-904

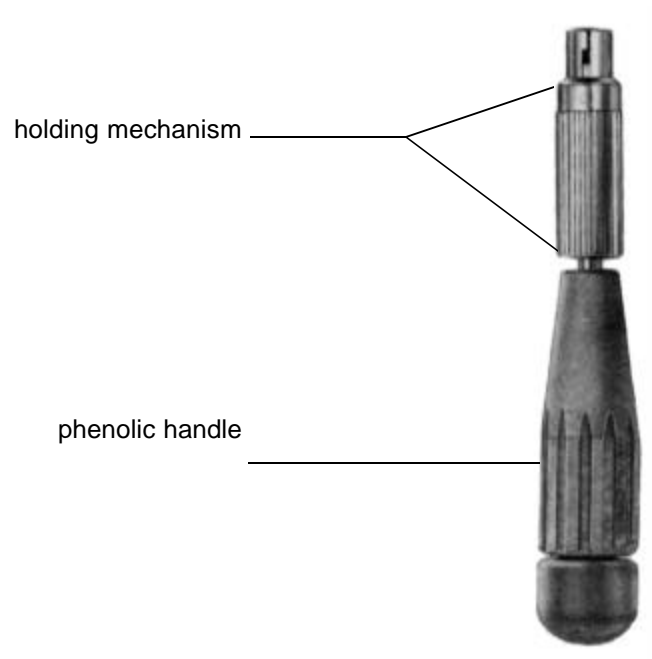

KMedic Product Information

Instrument type/name:	QC (Quick Coupling) Handles
aka:	QC handles
Raw material:	Working end: forgings from stainless steel Handles: stainless steel or phenolic
Surface:	Sand-blasted satin finish
Main function:	To hold quick-coupling drills, countersinks, taps and screwdrivers
Where used mostly:	Orthopedic surgery (fractures)
Important product features:	The handles are available in two sizes to match instrument sizes.
Useful hints in usage:	To insert working tip, retract the handle and snap it forward.
Special care instructions:	See autoclave temperatures for phenolic handles. Lubricate moving parts.
Other comments:	
Instrument subtypes:	

Depth Gauges

Small Screw Depth Gauge
KM 47-936

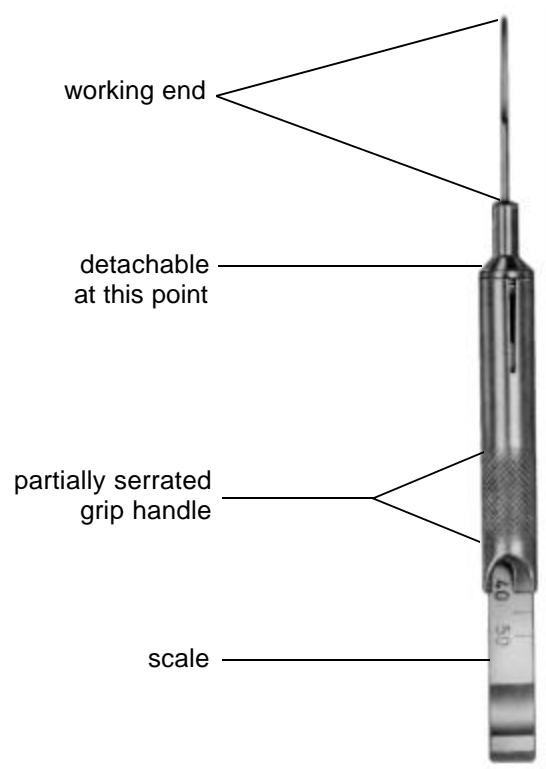

KMedic Product Information

Instrument type/name:	Depth Gauges
Raw material:	Bar stock from stainless steel
Surface:	Silk matte satin finish
Main function:	To determine screw length required during internal fracture fixation
Where used mostly:	Orthopedic surgery (fractures)
Important product features:	Depth gauges are millimeter graduated. Depth gauges snap apart for easy cleaning. They are calibrated with the size of the screw head taken into account.
Useful hints in usage:	A depth gauge should be used only after countersinking has been performed. The number indicated by the gauge indicates the screw size needed to engage the total depth of the bone. The distal (far) tip should be periodically checked. Depth gauges may not be substituted from different size sets—inaccurate readings may result.
Special care instructions:	When not in use, retract the delicate measuring end inside the gauge. Disassemble for cleaning.
Other comments:	
Instrument subtypes:	

Drill Sleeves

Double Drill Sleeve
KM 47-972

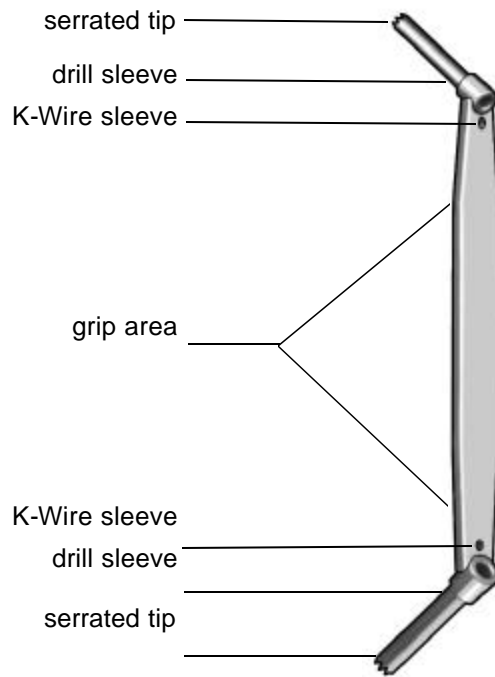

KMedic Product Information

Instrument type/name:	Drill Sleeves and Guides
Raw material:	Bar stock from stainless steel
Surface:	Sand-blasted satin finish
Main function:	Used with drills and taps to place accurate holes and protect surrounding tissue
Where used mostly:	Orthopedic surgery (fractures)
Important product features:	They are available in a number of sizes and styles, for use with drill bits and taps of varying sizes. Double drill sleeves offer variable size working ends. Some models have serrated ends to prevent slippage. Some drill guide models have color-coded ends for easy identification.
Useful hints in usage:	When possible, disassemble for cleaning.
Special care instructions:	
Other comments:	
Instrument subtypes:	

Screwdrivers

Hexagonal Screwdriver
KM 48-353

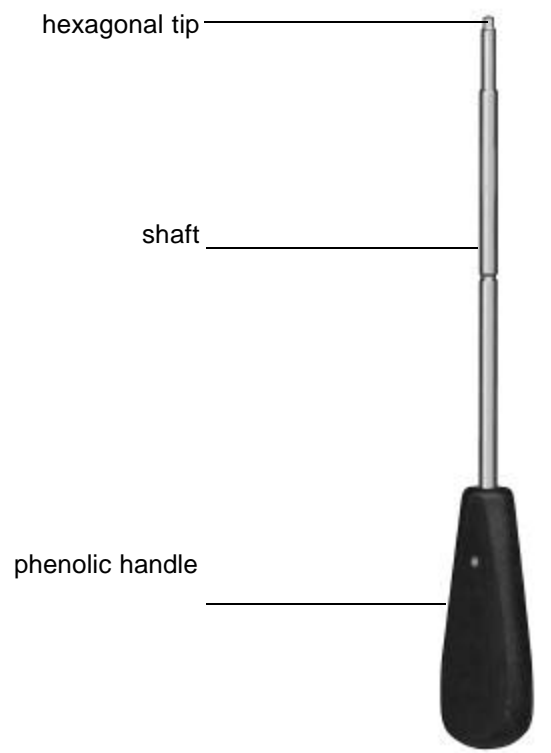

KMedic Product Information

Instrument type/name:	Screwdrivers
Raw material:	Working end: bar stock from stainless steel Sleeve: bar stock from stainless steel Handle: phenolic or stainless steel
Surface:	Silk matte satin finish
Main function:	To place and remove bone screws
Where used mostly:	Orthopedic surgery (fractures)
Important product features:	Various sizes and styles are available. An interchangeable screwdriver set is available. Some screwdriver bits come with a detachable handle—those have a Quick-Coupling (QC) end to fit to a QC handle. The function of the sleeve is to pick up and hold the screw before insertion in the fracture site.
Useful hints in usage:	The quality of the hex tip should be checked before each procedure—a damaged tip may damage the screw socket, making it very difficult or even impossible to insert or remove screws.
Special care instructions:	See autoclave temperatures for phenolic handles.
Other comments:	
Instrument subtypes:	

Bending Templates

7-Hole Template
KM 47-942

made of soft aluminum to
conform to bone surface

circles match screw
slots on plates



KMedic Product Information

Instrument type/name:	Bending Templates
Raw material:	Anodized aluminum
Surface:	
Main function:	To simulate required plate bending
Where used mostly:	Orthopedic surgery (fractures)
Important product features:	They are color coded. Various sizes are available. A bending template allows the plate placement to be planned exactly. They are also economical.
Useful hints in usage:	
Special care instructions:	
Other comments:	
Instrument subtypes:	

Plate Bending Instruments

Small Plate Bending Irons
KM 47-915, KM 47-916

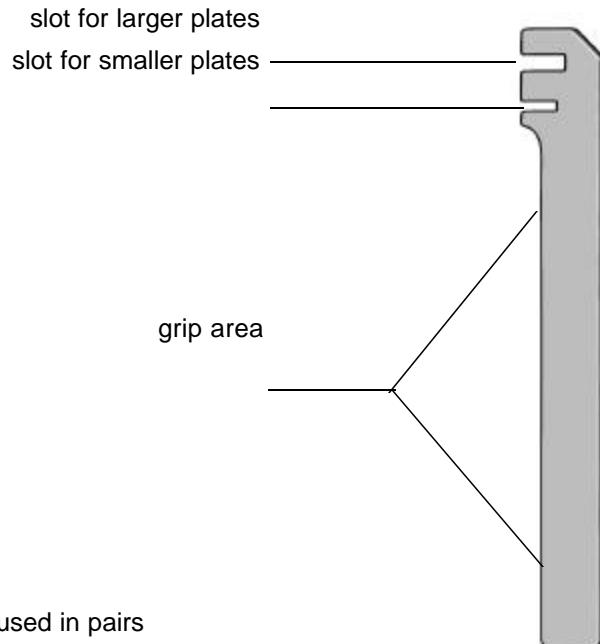
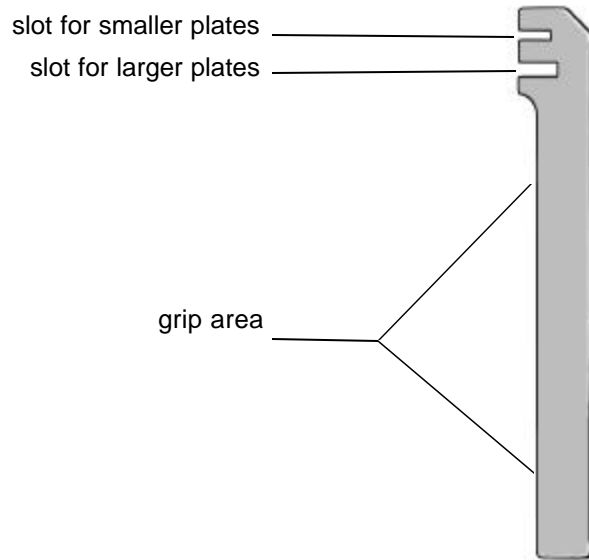

Note: used in pairs

KMedic Product Information

Instrument type/name:	Plate Bending Instruments
Raw material:	Forgings from stainless steel and stainless steel bar stock
Surface:	Silk matte satin finish
Main function:	To bend or cut plates for proper fit in fracture fixation
Where used mostly:	Orthopedic surgery (fractures)
Important product features:	Various sizes and styles are available.
Useful hints in usage:	Select the proper size to match the implant.
Special care instructions:	To avoid weakening plates, do not bend or twist them sharply. Never reverse bend, bend or twist at a plate hole. Do not bend at a sharp angle. Discard any plate which has been improperly bent—this prevents later complications from plate breakage.
Other comments:	
Instrument subtypes:	

Instrument Racks

Lambotte SmartRack
KM 98-190

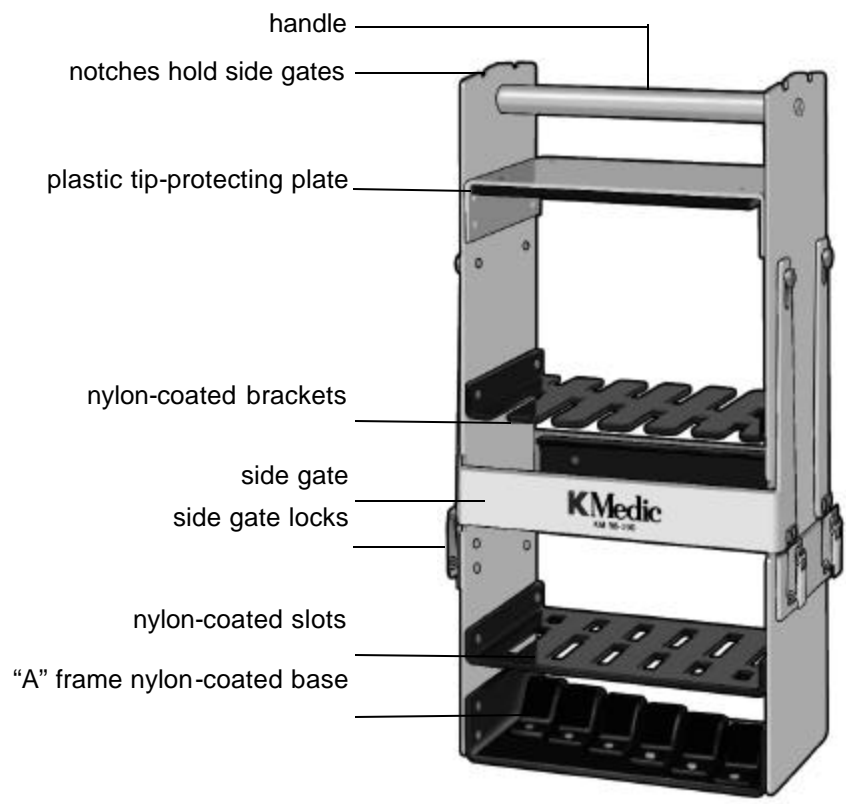

KMedic Product Information

Instrument type/name:	Instrument Racks
aka:	SmartRacks™
Raw material:	Corrosion-resistant anodized aluminum
Surface:	Area of instrument contact is nylon coated.
Main function:	For sterilization and storage
Where used mostly:	Orthopedic surgery
Important product features:	The racks are lightweight. Nylon-coated brackets prevent metal-to-metal contact. The plastic plate on the underside of the top bracket protects sharp tips from damage. The locking side arm prevents instruments from falling out. The rack brackets are deep. The patent-pending base keeps instruments upright during loading and unloading. The racks are autoclavable to 270° F.
Useful hints in usage:	
Special care instructions:	Store racks with side arms in locked position.
Other comments:	
Instrument subtypes:	Hoke SmartRack™ Brun SmartRack™ Cobb SmartRack™ Hibbs and Brun SmartRack™ Lambotte SmartRack™

12. KMedic Instrument Care Instructions

12.1 Instrument Longevity Through Proper Care

The purchase of KMedic instruments represents a considerable investment for our customers. By following these guidelines our customers can protect their investment and ensure many years of productive and satisfactory performance.

12.2 Maintaining the Surface

New Instruments

Newly purchased instruments must be cleaned, lubricated and autoclaved immediately before use.

Correct Use

Obvious as it sounds, it bears repeating: instruments are designed for a particular purpose and should be used only for that purpose. Even the strongest instrument can be damaged when used inappropriately, i.e., when a nail splitter is used to cut wire.

Water and Stainless Steel

Ordinary tap water contains minerals that can cause discoloration and staining. Therefore, we recommend the use of distilled water for cleaning, disinfecting, sterilizing and rinsing instruments. To avoid staining, use a cleaning solution with a pH near neutral (7). Instruments should be placed in distilled water immediately after use. They should never be placed in saline solution, as it may cause corrosion and eventually irreversible pitting.

Manual Cleaning and Soaking

When handling instruments, be very careful not to damage their fine tips and mechanisms. If instruments have been exposed to blood, tissue, saline or other foreign matter, they must be rinsed in warm (not hot) water before these substances are allowed to dry. Failure to do so may result in rust. After rinsing, immerse them in a cleaning and disinfecting solution.

Because many compounds, including certain chemicals, are highly corrosive to stainless steel, rinse and dry instruments immediately, in case they have come in contact with any potentially harmful substances.

If no ultrasonic cleaner is available, clean the instrument very carefully. Pay particular attention when cleaning box locks, serrations, hinges and other hard-to-reach areas. What's more, use nylon (not steel) brushes, such as KM 39-684, and warm (not hot) cleaning solutions. Follow the manufacturer's instructions for the preparation of the cleaning solutions. Remember to change these solutions daily.

12.3 Ultrasonic Cleaning

Ultrasonic cleaning is the most effective and efficient way to clean instruments. To maximize its effectiveness, instruments should be cleaned of all visible debris before they are put into an ultrasonic cleaner. Please note that chrome-plated instruments may rust if they are not dried and lubricated immediately after sterilization. In addition, we recommend the following:

- Do not mix dissimilar metals, e.g., chrome and stainless, in the same cycle.
- Use only designated cleaners.
- Open all instruments so ratchets and box locks are accessible.
- When possible, disassemble instruments for optimal cleaning.
- Avoid piling instruments on top of each other when loading and follow the manufacturer's instructions.
- Remove and rinse off instruments immediately after the cycle is finished.
- Allow instruments to air-dry thoroughly.
- Lubricate all moving parts after cleaning and before sterilization.
- Use only surgical lubricants, which can penetrate the instruments during the sterilization process.
- Change the water in the cleaner regularly.

12.4 Instrument Checkup

The best time to review the condition of instruments is after they have been cleaned and lubricated and have cooled off. Consider the following:

Function:

“Sharps” must cut cleanly (resharpen if needed) and close properly. Check for burrs along the cutting edges. Needle holders and clamps must engage properly and meet correctly at the tips.

Surface:

Carefully inspect surfaces for any sign of staining, cracking or other irregularities. Common sources of staining are:

- Inadequate cleaning
- Mixing dissimilar metals
- Impurities in the water
- Unsuitable or improper preparation and usage of cleaning and disinfecting or maintenance agents
- Noncompliance with operating procedures of cleaning and sterilizing equipment

For further information regarding staining, see Section 13, Tips for Troubleshooting.

12.5 Lubrication and Autoclaving

All instruments must be properly cleaned before autoclaving. Then their moving parts, such as box locks and hinges, should be well lubricated. Be careful to use surgical lubricants and not industrial oils. Always sterilize instruments in the open, unlocked position. We recommend that instruments be wrapped in cloth and then placed in the container, or that a cloth be put on the bottom of the pan to absorb moisture. The cloth should be pH(7) neutral and have no residue of detergents. Finally, avoid sudden cooling. Instruments should be allowed to air-dry, not rinsed or dried off.

12.6 Cold Sterilizing or Disinfecting

Prolonged immersion in disinfecting or sterilizing solution can damage surgical instruments. Do not soak instruments for longer than 20 minutes. To render the instruments sterile and ready for use, use an autoclave cycle.

Caution:

Instruments with tungsten carbide inserts, such as wire cutters, needle holders and TC scissors, should never be immersed in sterilizing solutions containing benzyl ammonium chloride (BAC). BAC will soften and dissolve the tungsten carbide. Never use bleach as it will cause severe pitting.

12.7 Storage

Once instruments are thoroughly dry, store them in a clean, dry environment. Never put them in areas where chemicals may emit corrosive vapors or where temperature and moisture variations could cause condensation on the instruments.

12.8 KMedic Quick Instrument Care Checklist

1. Rinse and soak soiled instruments immediately after use. Thoroughly clean before autoclaving.
2. Clean, autoclave and sterilize instruments in an open position.
3. Do not stack or entangle instruments.
4. Follow the manufacturer's recommendations when using equipment and cleaning solutions.
5. Keep instruments properly lubricated.
6. Inspect instruments regularly.

13. Tips for Troubleshooting

This guide is intended as a quick reference to handle many of the most basic questions and problems regarding surgical instruments.

13.1 Staining

Staining is most frequently the result of improper or inadequate cleaning.

Stains can be caused by mineral deposits in the water or electrolysis. Instruments should be cleaned in distilled water to avoid this. Staining should not be confused with rusting.

Blue Stains

This discoloration is usually caused by cold disinfecting or sterilizing solutions.

Solutions should be changed frequently, as corrosion may otherwise occur. Distilled water will also inhibit discoloration.

Black Stains

This discoloration can occur when instruments are exposed to ammonia, which is present in many hospital cleaners, and are not then adequately rinsed.

When possible, avoid using cleaning agents with ammonia, and always rinse instruments thoroughly.

Black stains can sometimes be caused by residues of chemicals used to clean the steam pipes.

Brown Stains

Brown stains are probably the result of oxidation and should not be confused with rust (see Rust/Corrosion 13.4). It forms naturally on stainless steel and helps prevent atmospheric corrosion. It should not be a cause of concern.

13.2 Spotting

Spotting is usually the result of improper cleaning. It may be caused by the water in which instruments are washed or by detergent residues in the wrapping material.

Light Spots

Mineral-rich tap water or detergent residues may leave deposits. Rinsing the instrument in distilled water will generally remove these deposits; if this fails, they can usually be cleaned off using a special, nonabrasive stainless steel cleaner or stain remover.

To avoid this problem, thoroughly dry instruments in the autoclave and avoid using cloths with detergent residues.

Dark Spots

Like light spots, these are usually caused by mineral deposits in the water used to clean, rinse and sterilize instruments. To avoid this problem, always use distilled water.

Rustlike Film

This film may be caused by residue in steam pipes. Unfortunately, little can be done in this situation.

The film may also be caused by chemical compounds used to treat water. As a result, iron may be deposited on instruments. Take this up with hospital engineering staff. Use distilled water to clean instruments.

13.3 Miscellaneous Stains and Spots

Spots and stains may also be caused if too much or the wrong kind of detergent is used to wash the instruments. Use a cleaner formulated specifically for surgical instruments.

13.4 Rust/Corrosion

If treated properly, stainless steel does not usually rust. Brown discoloration, which looks like rust to the ordinary eye, is often mistaken for rust.

Is It Rust?

A quick test to check whether you are dealing with rust or discoloration is to take an ordinary rubber eraser and try to rub away the imperfection—if you are able to do so, the problem is not with the instrument, and you should look into possible causes in the care and handling of the instrument.

If the instrument is corroding, it can be seen with a magnifying glass, because small pits begin to form in the steel. Such instruments should be removed from circulation and no longer used.

Corrosive Substances

Rusting may be the result of exposure to salts, saline, blood, iodine, chloride, bleach or other aggressive substances or due to the use of abrasives in the cleaning process, which can wear away the passive layers.

Surgical instruments should only be cleaned with solutions which the manufacturer has specifically stated are safe for such use.

Inadequate Cleaning

Corrosion can also be the result of inadequate cleaning. If blood or other bodily secretions are allowed to remain on the instruments, corrosion may occur. This is particularly a problem in hard-to-clean areas such as jaw serrations, box locks and ratchets. Instruments should be cleaned in the open position, and whenever possible should be disassembled.

Instruments should also be cleaned in distilled water. Deposits may form on instruments if they are washed in tap water, which may cause spotting and eventually corrosion.

Incomplete Drying

Incomplete drying may also end in corrosion—instruments should not be removed from the autoclave until they have been thoroughly dried.

Lubrication

Instruments should always be carefully lubricated. Failure to do so may result in wear, which could lead to corrosion.

Improper Usage

Improper usage is another common cause of corrosion. When corrosion appears at stress points in an instrument, e.g., at the jaws or box lock, this may be a sign of improper usage.

Improper Marking

Rust can also be caused by improper marking of the instrument with an engraver. Never mark anything on a box lock since it may weaken it.

Rust Transfer

Rust transfer can occur when instruments made of dissimilar metals come into contact for an extended period of time—to avoid this, wash and sterilize instruments of different metals separately.

Transfer rust can usually be removed with a rubber eraser. If neglected, however, rust may begin to mar the surface.

13.5 Pitting

Pitting may be caused by the use of improper cleaning agents, such as saline or bleach. Use only cleaners formulated for use with surgical instruments.

It may also be the result of the use of improper concentrations of cleaning agents, or cleaning agents which have a pH level which is too acidic or alkaline. Avoid using these kinds of detergents. The optimal pH for a cleaning fluid is close to neutral, ca. pH(7).

Pitting may also occur in the ultrasonic cleaner if instruments of different metals are cleaned in the same cycle. This can also occur in the autoclaving process.

13.6 Broken Instrument

An instrument should not normally break if it is being used for its intended purpose.

Breakage is likely the result of either an instrument being used for something other than what it was designed for, or being used to perform a task beyond its capacity, e.g., a wire cutter with a maximum cutting capacity of .045" is used to cut a wire of a larger size.

Another cause of breakage comes during the ultrasonic or autoclaving process. Instruments should be cleaned and autoclaved in the open, not locked, position. In the locked position, the heat may make the instrument expand and crack the box lock.

Instruments may also break as the result of careless handling. Some simple guidelines:

- Open all locked instruments
- Don't overload instruments in the ultrasonic cleaner
- Always sort instruments carefully
- Delicate or sharp instruments should be separated—especially microsurgical instruments
- Clean and store delicate or sharp instruments in specialty trays and containers

In the rare case that a flaw in the material or workmanship caused the breakage, KMedic will replace the item free of charge.

13.7 Damaged TC Insert

Tungsten carbide inserts, while more durable than steel, are not designed to last forever. It is possible that damaged or worn inserts may simply need replacement.

Premature wearing can be avoided by always using the instruments for their intended purpose. KMedic guarantees carbide inserts for three years against manufacturing and material defects.

Damage may also result from improper cleaning. Instruments with TC inserts should never be cleaned in sterilizing solutions containing benzyl ammonium chloride (BAC). BAC will soften and dissolve the tungsten carbide.

Section C

14. Glossary of Useful Terms

abduction	to draw away from the center line of the body
abrasive	substance which removes or deteriorates a surface by friction
acetabulum	the large, cup-shaped cavity at which the femur, or thigh bone, joins the hip
adduction	to draw toward the center line of the body
angled	bent, not straight
anodized aluminum	aluminum which has been specially treated through an electrochemical process which forms a protective oxide layer, rendering it corrosion resistant; used to make instrument racks; the oxide layer of anodized aluminum may be colored
AO	<i>Arbeitsgemeinschaft fuer Osteosynthesefragen</i> ; an international organization dedicated to research of internal bone fixation (osteosynthesis), as well as instrument design for and documentation of osteosynthesis
approximate tips	instrument tips have proper alignment
arthrodesis	fusion of a joint in a surgical procedure
arthroplasty	surgical reconstruction of a joint
arthroscopy	examination of the inside of a joint with an arthroscope
articular	pertaining to a joint
articulate	divided into or separated by joints
aspirate	to remove fluid or gas from a cavity or joint area using suction
atraumatic	not having a crushing or biting effect on tissue
autoclave	machine for the sterilization of surgical instruments
bayonet	a blade that is offset (bent) from the axis of the handle
biopsy	the removal and examination of tissue from a living body

blank	first stage in the actual manufacture of an instrument; involves the creation of the basic form of the instrument; may be created through hot or cold forging; see: forgings
bone graft	use of bone tissue to reconstruct an area of missing bone
box lock	the area of an instrument at which the male and female parts of the instrument are joined
bunionectomy	the resection of a bunion, an abnormal prominence at the mid-section of the first metatarsal head (below the big toe)
calcaneus	bone of the heel
caliper	a compass with bent or curved jaws used to take measurements
cancellous	spongy and latticelike (soft) bone
cancellous bone	ends of long bones, most of flat and short bones (latticelike bone)
cannula	a tube for insertion into a duct or cavity; used to drain fluids
carpal	pertaining to the group of eight small, short bones which form the wrist
cartilage	white substance covering joint surfaces which can be compressed, allowing for motion without friction
catheter	instrument used to remove fluids from a cavity in the body
cavitation	a process to clean instruments using sound waves in an ultrasonic cleaner
cerclage	wire used in the treatment of long, spiral fractures; it is placed around the bone and tightened; used also in other cases in which temporary fixation is required
cervical	refers to the area at the upper portion of the spine
chisel	wedgelike instrument with a blade, generally used with a mallet to cut and shape bone
chondral	pertaining to cartilage

cleaning agents	detergents designed for the removal of protein soils, a necessary step in cleaning instruments
closed reduction	to set a broken bone by compression
complex fracture	situation in which, after reduction, there is still no contact between the main fragments
compound fracture	an open fracture in which the bone is broken completely across
corrosion	the gradual wearing away of a surface; may be caused chemically
corrosive	causing the gradual dissolving and deterioration of a substance, especially by chemicals
cortex	external layer of cancellous bone or middle layer of long bones
cortical	pertaining to the outer layer of cancellous bone (cortex) or middle layer of long bones (hard bones)
cortical bone	solid portion of a bone; surrounds medullary canal
cranium	the skull or brain pan
critical dimension	area of a surgical instrument which must correspond very closely to product specifications, as in the parts that need to mate with other parts, e.g., QC handle, screwdrivers, etc.
curette	spoon-shaped instrument used to scrape, shape and remove bone
curved	continuously deviating from a straight line, as in a curved blade or handle
debridement	removal of foreign material or contaminated tissue to expose surrounding healthy tissue
decontamination	removal of microbes to make instruments safe for use
dilator	instrument used to stretch or enlarge an opening
dissect	to cut or separate tissue
dissector	instrument used to cut apart or separate tissue

distilled water	purified liquid condensed from boiled water; preferred choice for instrument cleaning
double-action	applies power in two directions, used in instrument mechanism to increase surgeon's power and to control and reduce fatigue
dull	blunted, not sharp
electrolysis	decomposition of a chemical compound into its ions by the passage of an electrical current through a solution of it (electrolyte)
electrolytic	having to do with electrolysis or with an electrolyte
elevator	instrument used for lifting or retaining at a greater height; sharp versions are used to strip the periosteum
etching	process by which instruments are marked to facilitate identification and tracking; an electrochemical process is used in order to preserve the instrument surface; etching should never be performed on an instrument joint
excision	the cutting away or removal of tissue, bone, etc.
fascia	sheet of fibrous tissue encasing the body beneath the skin, enclosing muscles and muscle groups, and separating their layers
fasciotomy	removal of the fascia
femur	bone of the thigh
fenestrated	pierced with one or more openings
fibula	smaller bone of the leg
fine	having thin or slender jaws or tips
finger rings	rings at the handling end of an instrument, used to control the jaws
fixation	to hold, suture or fasten in a fixed position, e.g., fractured bone is stabilized in order for healing to take place; may be temporary or permanent, external or internal; see: osteosynthesis
forging	molded metal, the first step in the actual manufacture of an instrument

fracture	a break in the continuity of bone; see: compound fracture, simple fracture
golding	the marking of instrument with a gold plating usually on the handles for easy identification; indicates the instrument has TC inserted or welded to its tips
goniometer	device used to measure the flexibility and extension of the finger
gouge	instrument used to scoop bone away from an area
hardening	process by which steel is heated to very high temperatures in order to increase the metal's hardness or durability; also known as tempering
head	large, rounded end of a bone
heavy	having broad jaws or tips
hemostat	small surgical clamp used to constrict a blood vessel
hex size	refers to the hexagonal tip of an instrument made to mate precisely, as in screwdrivers
humerus	the upper arm bone
implant steel	special grade of stainless steel used for manufacturing screws and plates for implantation in bone fixation procedures
intervertebral	between the vertebrae
intramedullary	inside the medullary canal
ISO	The International Organization for Standardization; the organization which sets the manufacturing standards for certain surgical instruments, e.g., internal fixation devices
jaws	grasping or cutting tips of a ring-handled instrument
lamina	a thin layer of bone or membrane
laminectomy	excision, or cutting away, of the posterior arch of a vertebrae
lap joint	joint for a two-part instrument fastened in an overlapping fashion; used as an alternative to box locks
ligament	tissue which serves to connect the ends of bones, binding them together or preventing movement
malleable	flexible, able to be bent

mallet	hammerlike instrument used to apply force, e.g., to chisels and osteotomes
mating parts	parts which interlock precisely, as in implant management instruments
medullary canal	bone marrow canal
meniscus	crescent-shaped structure attached to the tibia (knee)
metacarpal	pertaining to the group of five long, thin bones which form the palm area of the hand
metatarsal	pertaining to the group of five rod-shaped bones which form the arch of the foot
micro	small, narrow or delicate
micrometer	device used to take very fine measurements
milling	a stage in the manufacture of an instrument, in which the hot or cold forged blank is shaped, e.g., to create the box lock
mycotic	pertaining to mycosis, any disease caused by a fungus
necrosis	death of areas of tissue or bone surrounded by healthy tissue; can be caused by excessive heating of bone during drilling
neuroma	a tumor or new growth composed largely of nerve cells and fibers; a tumor which grows from a nerve
nonunion	failure of segments of broken bone to reunite
O.R.I.F.	Open Reduction, Internal Fixation
oblique	inclined; sloping
obturator	object which closes an entrance or cavity
occlude	to close or obstruct
olecranon	from the Greek, meaning "elbow"
open reduction	surgical procedure to reduce a fracture; open reduction may include the use of an internal fixation device
orthopedics	area of medicine which deals with the treatment of disorders involving the structures of the body which enable movement, primarily the skeleton, joints, muscles and fascia

osteotomy	the removal of part or the entirety of a bone
osteosynthesis	coined by Dr. Lambotte, refers to the process of surgical joining of bone fragments by internal fixation; now also used to refer to external fixation
osteotome	a chisel-like instrument, often used with a mallet to cut or sculpt bone, particularly cancellous bone
osteotomy	the surgical cutting or shaping of a bone; may include repositioning and/or controlled fracture
passivation	electrochemical treatment of stainless steel to create passive layers
passive layers	protective layers formed on stainless steel, the result of a high chromium content, which inhibit corrosion
patella	the knee cap
pelvis	bony structure which supports lower abdomen
periosteum	connective tissue covering the external surface of a bone
pH	measurement for the acidity or alkalinity of a substance; distilled water has a neutral pH of 7
phalangeal	refers to both the bones which form the toes or the bones which form the fingers and thumb; each group of phalanges includes 14 bones
pitting	indentation on the surface of an instrument, caused by corrosion
QC handle	quick-coupling handle, designed to mate quickly with QC working ends, as in some screwdrivers, taps and drills
radius	the bone of the forearm which rotates
ratchet	locking mechanism located on the shank portion of an instrument
reduction	restoration of a bone to its normal position; see: closed reduction and open reduction
resection	the operation of cutting out or removing a section or segment, e.g., an organ
retractor	instrument used to grasp, retain or hold back tissue, organs or bone for surgical exposure

rongeur	a forcep used to cut or remove small pieces of bone and tissue
saline	solution of sodium chloride and distilled water; saline should not be used to clean instruments, as it may cause corrosion
sand-blasting	a surface treatment process by which tiny glass or sand beads are blasted under high pressure against the surface of a stainless steel instrument to achieve a homogeneous surface; used in cases where hand polishing is not possible or recommended
saw	a notched blade used for cutting
scissors	cutting instrument with two shearing blades
screw lock	a lap joint which is fixed with a screw, as with scissors
self-retaining	capable of being placed in a fixed position, as in a self-retaining clamp
semi-box lock	box lock which may be disassembled for cleaning
serrations	the small grooves seen on the edge or tips of an instrument; can be vertical, horizontal or diamond patterned
sesamoid	small bone of the foot, usually found below the head of the first metatarsal bone (closest to the big toe)
sesamoidectomy	the removal of a sesamoid bone
shanks	midsection of a ring-handled instrument; site of ratchet
sharp	implies a pointed tip, as in a rake retractor; frequent nickname for any sharp instrument, e.g., scissors
simple fracture	a fracture which does not produce an open wound in the skin; also called "closed fracture"
skeleton	the body's framework; in humans, the collective bones of the body

smooth	without teeth; may be serrated, but does not have a projection to penetrate tissue
snare	an instrument with a wire loop used to remove a tissue growth by encircling it and removing the growth
soft tissue instruments	basic instruments required for incision, subcutaneous tissue dissection and wound closure
spotting	markings on an instrument caused by nonadhesive surface contaminants
staining	markings on an instrument caused by semiadhesive surface contaminants; difficult to remove
stainless steel	alloy of steels; the main metal is iron alloyed with chromium, carbon, manganese, silicon, etc.; chromium helps the steel to be rust resistant; other elements can be added so it can perform specific functions; used in the manufacture of most surgical instruments
steam sterilization	process for the sterilization of instruments, using saturated steam at a set temperature and for a set time period; see: autoclave
sterilization	process that removes all microbes, including spores, to render instruments safe for use; usually achieved with a steam or gas process; see: autoclave, steam sterilization
sternum	the breast bone
strabismus	deviation of the eye which prevents both eyes from looking at an object at the same time; cross-eye
suction tip	a hollow, tubelike instrument which is attached to a vacuum for suction
synovectomy	removal of a synovial membrane
synovium	membrane which lines the inside of a joint
tarsal	pertaining to the group of seven bones which form the ankle and heel
TC inserts	tungsten carbide inserts, soldered or welded into the jaw of an instrument to provide extra durability; TC inserts may also be replaced, extending the life of an instrument

teeth	small notches or projections used to grasp tissue and prevent the instrument from slipping
tempering	see: hardening
tenaculum	hooklike instrument used to seize and hold tissue
tendon	a cord of tissue which connects muscle to bone
tenotomy	dissection or cutting of tendon or muscle, as in hand, foot and eye surgery
thoracic	pertaining to the chest
tibia	shin bone
tissue	a group of cells which are specialized to perform a particular function
tolerance	the allowable amount of variation in the dimensions of an instrument
tonometer	instrument used to measure the tension or pressure of the eyeball or the blood pressure within blood vessels
tooling	machines, tools, fixtures and other devices which aid in the manufacture of instruments
tool steel	type of steel generally used for machine-shop tools, used in the manufacture of some instruments
toothed	see: teeth
traumatic	having a crushing or biting effect on tissue
traumatize	to wound or damage
trochanter	either of two bony processes, or protuberances, of the upper shaft of the femur which serves in the attachment of muscle
tungsten carbide	alloy used in the manufacture of inserts for instrument tips; harder than stainless steel; tungsten has the highest melting point of all metals
ulna	the inner and larger bone of the forearm
ultrasonic cleaner	mechanical cleaner which makes use of sound waves (known as cavitation) to clean instruments; used before lubrication and sterilization

15. Selected Bibliography

- Brooks Tighe, Shirley M. (1994). *Instrumentation for the Operating Room: A Photographic Manual* (4th ed.). St. Louis: Mosby.
- Smith, Mary F. & Stehn, Joette. (1993). *Basic Surgical Instrumentation*. Philadelphia: Harcourt Brace Jovanovich.
- National Association of Orthopedic Nurses. (1995). *Orientation to the Orthopedic Operating Room*. New Jersey: Jannetti.
- Papianer Wells, Maryann & Bradley, Mary. (1993). *Surgical Instruments: A Pocket Guide*. Philadelphia: Harcourt Brace Jovanovich.
- Smith, Maryalice. (1993). Effective Reprocessing: A Key to Instrument Longevity. *Materials Management* (60).
- Jackson, Ralph. (1988). *Doctors and Diseases in the Roman Empire*. London: British Museum Press.
- Draeger, Herbert & Gill, Werner. (1990). *Instrumentenkunde: Materialien und Aufbau, Pflege und Umgang*. New York: Thieme.
- DIN Deutsches Institut fuer Normung. (1989). *Medizinische Instrumente: Normen und weitere Unterlagen*. Koeln: Beuth.
- Texthammer, R. & Colton, C. (1994). *AO/ASIF Instruments and Implants: A Technical Manual* (2nd ed). New York: Springer.

16. Other Surgical Instrument Brand Names

Aesculap
ASSI
Baxter/V.Mueller
Biomet
Buxton
Codman
DePuy
Innomed
Jarit
Link
Medi-Tool
Miltex
Pilling/Weck
Ruggles
Scanlan
Sklar
Smith & Nephew Orthopaedics
Snap-ON
Snowden
Synthes
Tiemann
Walter Lorenz
Zimmer

Major Bone Anatomy

Major long bones are identified as any elongated bone of the extremities that consists of a diaphyseal shaft and wider epiphyseal articulating ends.

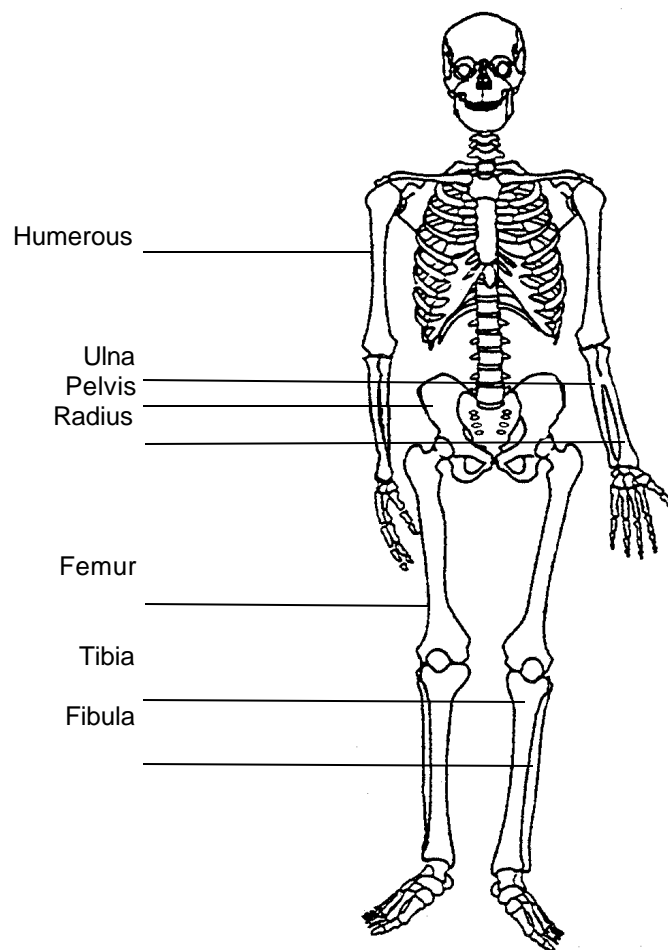

18. Index

Description	Page #
Abduction	C1
Abrasive	C1
Acetabulum	C1
Adduction	C1
Aluminum	A12
Angled	C1
Anodized aluminum	C1
AO	C1
Approximate tips	C1
Arthrodesis	C1
Arthroplasty	C1
Arthroscopy	C1
Articular	C1
Articulate	C1
Aspirate	C1
Atraumatic	C1
Autoclave	C1
Autoclaving	B129
Awls	B57
Bar Ratchet	B6
Basic Identification and Anatomy	B2
Bayonet	C1
Bending Templates	B121
Bibliography	C11
Biopsy	C2
Black Stains	B131
Blade Types	B7-B12
Blank	C2
Blue Stains	B131
Bone Curettes	B67
Bone Cutters, Trephines and Bone Rongeurs	B81
Bone Files and Rasps	B75
Bone Graft	C2
Bone Holding Forceps	B63
Bone Holding Jaw Types	B13
Bone Hooks	B63
Bone Plates	B105
Bone Saws and Bone Knives	B83
Bone Screws	B103
Box Lock	B3,C2
Breakage	B134
Brown Stains	B131

Description	Page #
Bunionectomy	C2
Calcaneus	C2
Caliper	C2
Cam Ratchet	B6
Cancellous	C2
Cannula	C2
Carpal	C2
Cartilage	C2
Cartilage and Tendon Instruments	B65
Catheter	C2
Cavitation	C2
Cerclage	C2
Cervical	C2
Chisel	C2
Chondral	C2
Chrome Plating	A13
Classification by Usage	B1
Cleaning Agents	C3
Cleaning, Manual	B127
Cleaning, Ultrasonic	B128
Closed Reduction	C3
Cold Sterilization	B130
Complex Fracture	C3
Compound Fracture	C3
Corrosion/Rust	B132, C3
Corrosive	C3
Cortex	C3
Cortical	C3
Countersinks	B109
Cranium	C3
Critical Dimension	C3
Curette	C3
Curved	C3
Debridement	C3
Decontamination	C3
Depth Gauges	B115
Dilator	C3
Disinfecting	B130
Dissect	C3
Dissecting Scissors	B27
Dissector	C3
Distilled Water	C4
Double Leaf Spring	B6
Double Spring	B5

Description	Page #
Double-Action Joint	B3, C4
Dressing/Thumb Forceps	B37
Drill Bits	B107
Drill Sleeves and Guides	B117
Drying	B133
Dull	C4
Electrolysis	C4
Electrolytic	C4
Elevator	B55,C4
Etching	C4
Excision	C4
Fascia	C4
Fasciotomy	C4
Femur	C4
Fenestrated	C4
Fibula	C4
Fine	C4
Finger rings	C4
First Article Sample	A6
Fixation	C4
Forceps	B31-B39
Forceps - QA Test	A15
Forging	C4
Fracture	C5
Glossary of Useful Terms	C1
Golding	C5
Goniometer	C5
Gouge	C5
Hand Drills	B101
Hand-Held Retractors	B51
Handle Types	B4
Hardening	C5
Head	C5
Heat Treatment	A9
Heavy	C5
Hemostat	C5
Hemostatic Forceps	B33
Hex size	C5
History of Surgical Instruments	A4
Hollow Handle	B4
Humerus	C5
Implant Steel	C5
Instrument Care Instructions	B127

Description	Page #
Instrument Racks	B125
Intervertebral	C5
Intramedullary	C5
ISO	C5
Jaw Types	B13,C5
Joint Types	B3
KMedic Certified	A3
KMedic Quality Assurance	A14
KMedic's Mission	A3
Lamina	C5
Laminectomy	C5
Lap Joint	B3,C5
Ligament	C5
Lubrication and Autoclaving	B129,B133
Major Bone Anatomy	C15
Major Product Groups	B14
Malleable	C6
Mallets	B71,C6
Manual Cleaning	B127
Manufacture of KMedic Instruments	A8
Materials Used in Manufacturing	A11
Mating parts	C6
Medullary canal	C6
Meniscus	C6
Metacarpal	C6
Metatarsal	C6
Micro	C6
Micrometer	C6
Microsurgical Instruments	B47
Milling	C6
Mycotic	C6
Necrosis	C6
Needle Holders	B41-B45
Needle Holders - QA Test	A15
Neuroma	C6
New Instruments	B127
Nonunion	C6
O.R.I.F.	C6
Oblique	C6
Obturator	C6
Occlude	C6
Oecranon	C6
Olsen Hegar Needle Holders	B45
Open Reduction	C6

Description	Page #
Operating Scissors	B25
Orthopedics	C7
Ostectomy	C7
Osteosynthesis	C7
Osteotome	C7
Osteotomes, Chisels and Gouges	B69
Osteotomy	C7
Other Surgical Instrument Brand Names	C13
Passivation	C7
Passive layers	C7
Patella	C7
Pelvis	C7
Periosteum	C7
pH	C7
Phalangeal	C7
Pitting	C7
Plaster Cast Instruments	B91
Plastics	A12
Plate Bending Instruments	B123
Polishing	A10
Prototyping	A6
QC (Quick-Coupling) Handles	B113,C7
Quality Assurance	A14
Radius	C7
Ratchet Lock	B5,C7
Raw Material Selection	A7
Reduction	C7
Resection	C8
Retaining Systems	B5,B6
Retractors	C8, B49-B53
Retractors - QA Test	A15
Ring Handle	B4
Rongeur	C8
Rust Transfer	B133
Rust/Corrosion	B132
Saline	C8
Sand-blasting	C8
Saw	C8
Scalpel Handles	B17
Scissors	B19-B29,C8
Scissors - QA Test	A15
Screw Lock	C8
Screwdrivers	B119
Selected Bibliography	C11

Description	Page #
Selection of KMedic Instruments	A6
Self-Retaining	C8
Self-Retaining Retractors	B53
Semi-Box Lock	C8
Serrations	C8
Sesamoid	C8
Sesamoidectomy	C8
Shanks	C8
Sharp	C8
Simple fracture	C8
Single Spring	B5
Skeleton	C8
Smooth	C9
Snare	C9
Soft Tissue Instruments	C9
Spinal Rongeurs (Neuro Rongeurs)	B89
Spotting	B131,C9
Spring Types	B5,B6
Staining	B131,C9
Stainless Steel	A11,C9
Stainless Steel Needle Holders	B41
Sterilization	C9
Sternum	C9
Strabismus	C9
Suction Tip	C9
Super-Cut Scissors	B23
Synovectomy	C9
Synovium	C9
Tamps	B73
Taps	B111
Tarsal	C9
TC inserts	C9
Teeth	C10
Tempering	C10
Tenaculum	C10
Tendon	C10
Tenotomy	C10
Thoracic	C10
Tibia	C10
Tips for Troubleshooting	B131
Tissue	C10
Tissue Forceps	B39
Titanium	A12
Tolerance	C10

Description	Page #
Tonometer	C10
Tool steel	C10
Tooling	C10
Tooling Stage	A6
Toothed	C10
Towel and Sponge Forceps	B35
Traumatic	C10
Traumatize	C10
Trochanter	C10
Tungsten Carbide	A12,C10
Tungsten Carbide Needle Holders	B43
Tungsten Carbide Scissors	B29
Tungsten Carbide, Damage to	B134
Ulna	C10
Ultrasonic Cleaning	B128,C10
Water and Stainless Steel	B127
Wire and Pin Cutters	B97
Wire and Pin Implants	B95
Wire and Pin Management Instruments	B99

**Orthopedic
Surgical
Instruments**

190 Veterans Drive
Northvale, NJ 07647
U.S.A.

201.767.4002
800.955.0559

Fax:
201.768.0494

On-line:
www.kmedic.com

March 31, 2000

PRODUCT ANNOUNCEMENT

As of March 31, 2000 we no longer offer Screws and Plates in our product line.

Please note, the Screws and Plates section in Surgical Instruments 101 is for instructional purposes only.

Blair Engelken
Vice President
Sales and Marketing