

IRRIGATION INSIDE A GREEN HOUSE



**PROTECTED CULTIVATION AND POST HARVEST
TECHNOLOGY [ASAE3204]**

B.Sc. Ag. (6th sem.)



Plant and Water

- Water serves a number of basic functions in a plant's life, constituting up to 95% of fresh weight.
- Water dissolves several substances and is the transport vehicle for the nutrients in plants.
- By means of cell turgor it provides rigidity and gives shape to several plant organs.

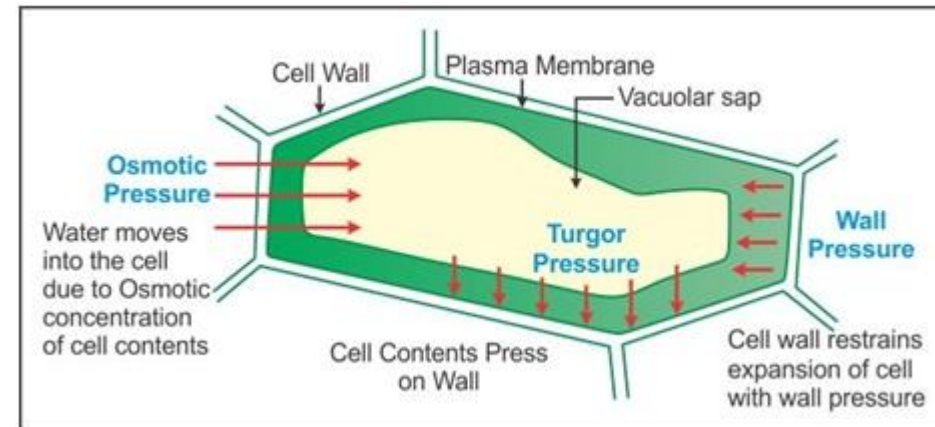
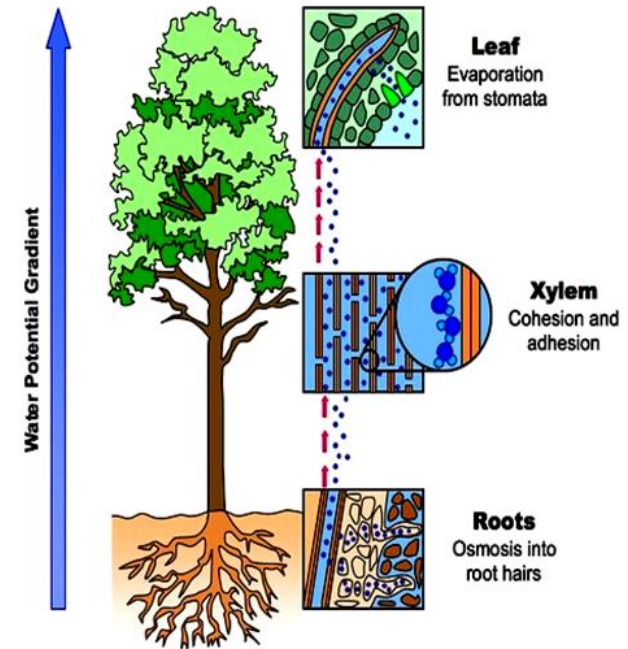



Plant and Water

- It is necessary for photosynthesis and participates in a large number of chemical reactions of plant metabolism.
- In addition, it allows plants to be cooled through its evaporation, by means of transpiration, absorbing heat and cooling the leaf surfaces.

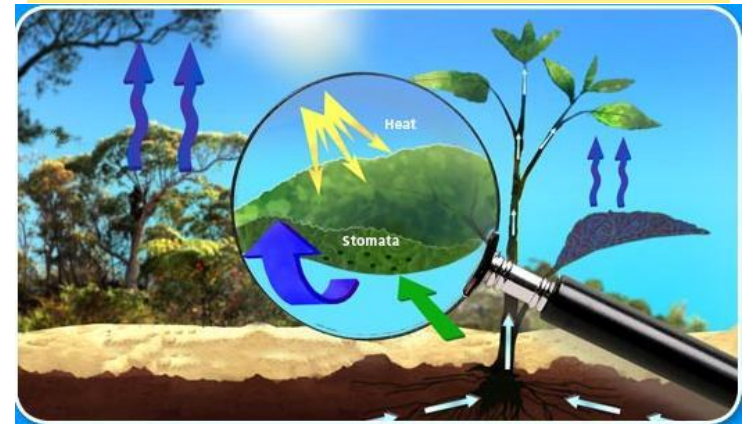
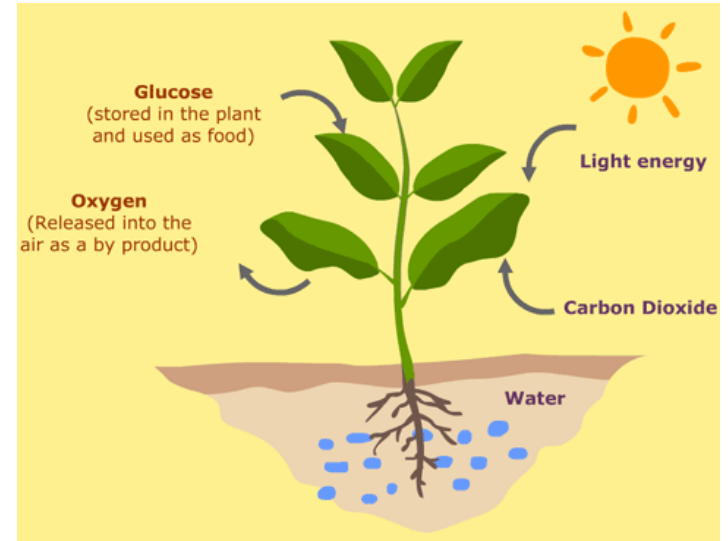



Transpiration

What is the importance of “Transpiration” ?

- Transpiration takes place, mainly, through the stomata of the leaves, that transfers water vapour from the plant to the atmosphere.
- Water losses by transpiration are the unavoidable cost for the plant in order to be able to fix CO_2 from the air, essential for photosynthesis and plant growth.
- The majority of the water is **absorbed passively** through the roots, as a result of transpiration. When transpiration stops, there is no passive absorption of water and nutrients, which can have negative effects for the plant.



Transpiration

- Transpiration requires energy (normally solar) for the water evaporation process. If the energy decreases, transpiration decreases.
- The energy supplies from the greenhouse heating systems also contribute to the evaporation process.
- In areas of low solar radiation some energy is applied to the greenhouse by maintaining a certain minimum temperature to promote transpiration.



Importance of Irrigation in GH

Water Stress

- A plant is considered to suffer water stress, or water deficit, when the water potential in its tissues decreases to the extent that it negatively affects the performance of the physiological processes.
- The causes of water deficit can be:
 - ❖ Low ψ in the soil, due to low water content or to **salinity**.
 - ❖ High **transpiration rate**.
 - ❖ High resistance to the water flux in the soil or in the plant

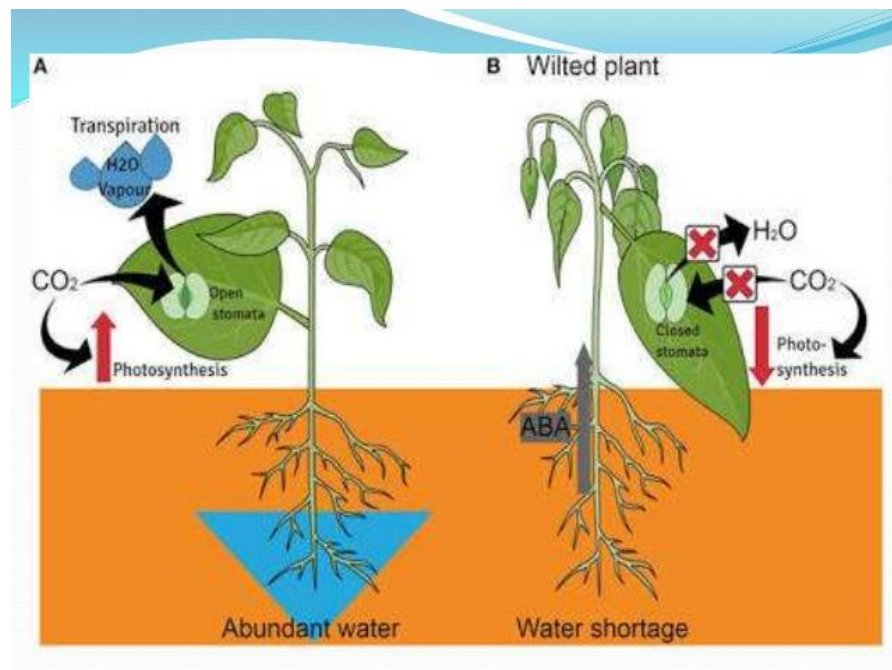



Importance of Irrigation in GH

Saline Stress

- A crop can survive under high salinity conditions, but the production will be seriously affected, quantitatively and qualitatively.
- Main causes of saline stress
 - Excessive fertilization
 - Salt supplied by irrigation water
 - Salinity conditions of soil

In greenhouse horticultural crops, the primary objective of irrigation is to avoid water stress, but also to avoid undesirable conditions of salinity at the root level.



Greenhouse Irrigation

Greenhouse crops are irrigated by following means

- applying water to the media surface through drip tubes or tapes
 - by hand using a hose
 - overhead sprinklers and booms
 - by applying water through the bottom of the container through sub-irrigation
- **Surface irrigation systems, mainly by furrows**, that were traditionally used in greenhouses are now no longer used.
- **Overhead sprinklers and hand watering** have a tendency to "waste" water and also wet the foliage, which increases the potential for diseases and injury.



Greenhouse Irrigation

Drip Irrigation System is mostly used in greenhouses. Why?

- Drip and sub-irrigation systems are the most efficient and provide greater control over the amount of water applied.
- Also, since the foliage does not become wet there is a reduced potential for diseases and injury.

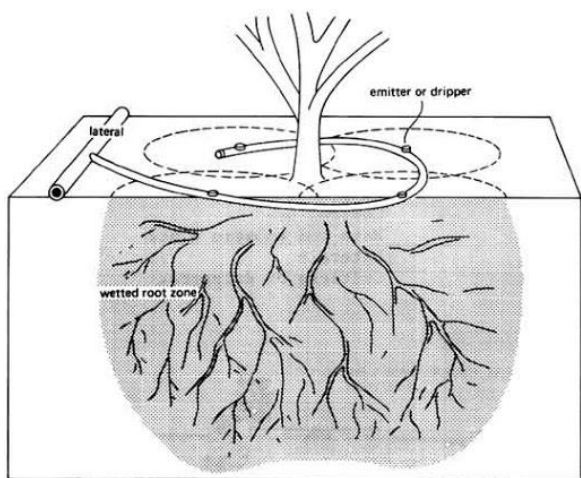

Drip Irrigation

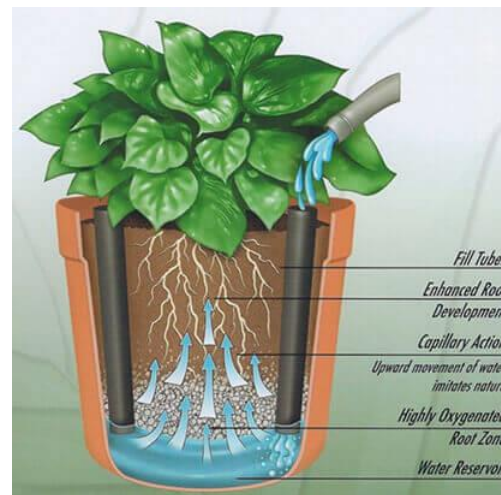

Sub-Irrigation



Drip Irrigation

Drip irrigation utilizes the concept of **applying small amounts of water through perforations in distribution lines to specific areas of application.**

- Drip irrigation can be a valuable tool for accurate growing medium moisture control.
- It also saves water and labour, and reduces the potential for groundwater pollution.
- Eliminate runoff of water missing the pot during overhead irrigation and the volume of water applied to the pot can be controlled.

Controlling drip systems with the use of a **tensiometer** placed in the growing medium to sense moisture tension and a small computer programmed to turn the system on or off when pre-set moisture tensions are reached, can reduce runoff from potted plants to **nearly zero.**



Drip Irrigation

Basic Layout

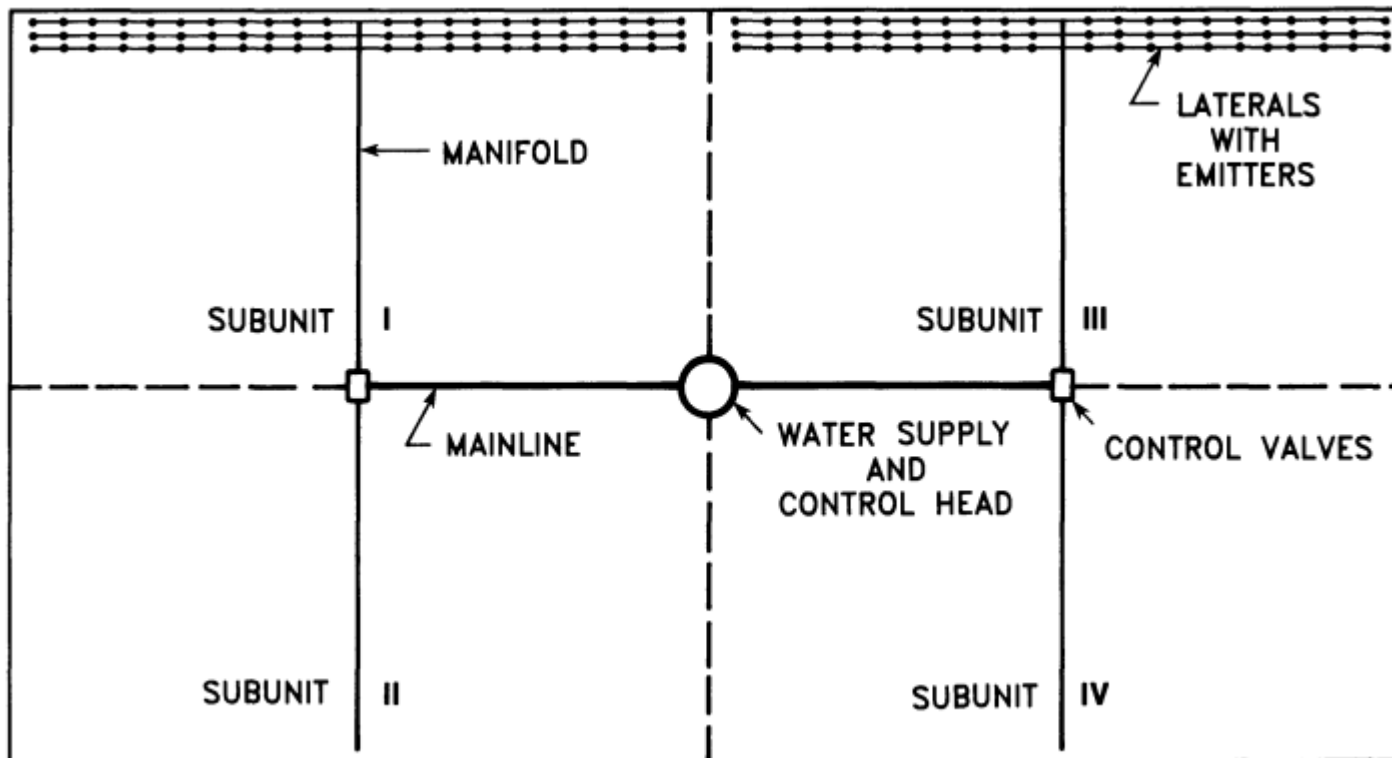

Typical two station split flow layout for trickle irrigation system with subunit I and III or II and IV operating simultaneously



Drip Irrigation

Control head includes:

- Pump station
 - Filtering Equipment
 - Fertilizer and chemical injection equipment
 - Controllers
 - Main pressure regulators
 - Valves and water measuring devices
- The main lines transfer water from the source to the manifolds.
- Usually control valves are used at the main line-to-manifold connections.
- The manifolds supply water to laterals that branch from it on one or both sides.



Drip Irrigation

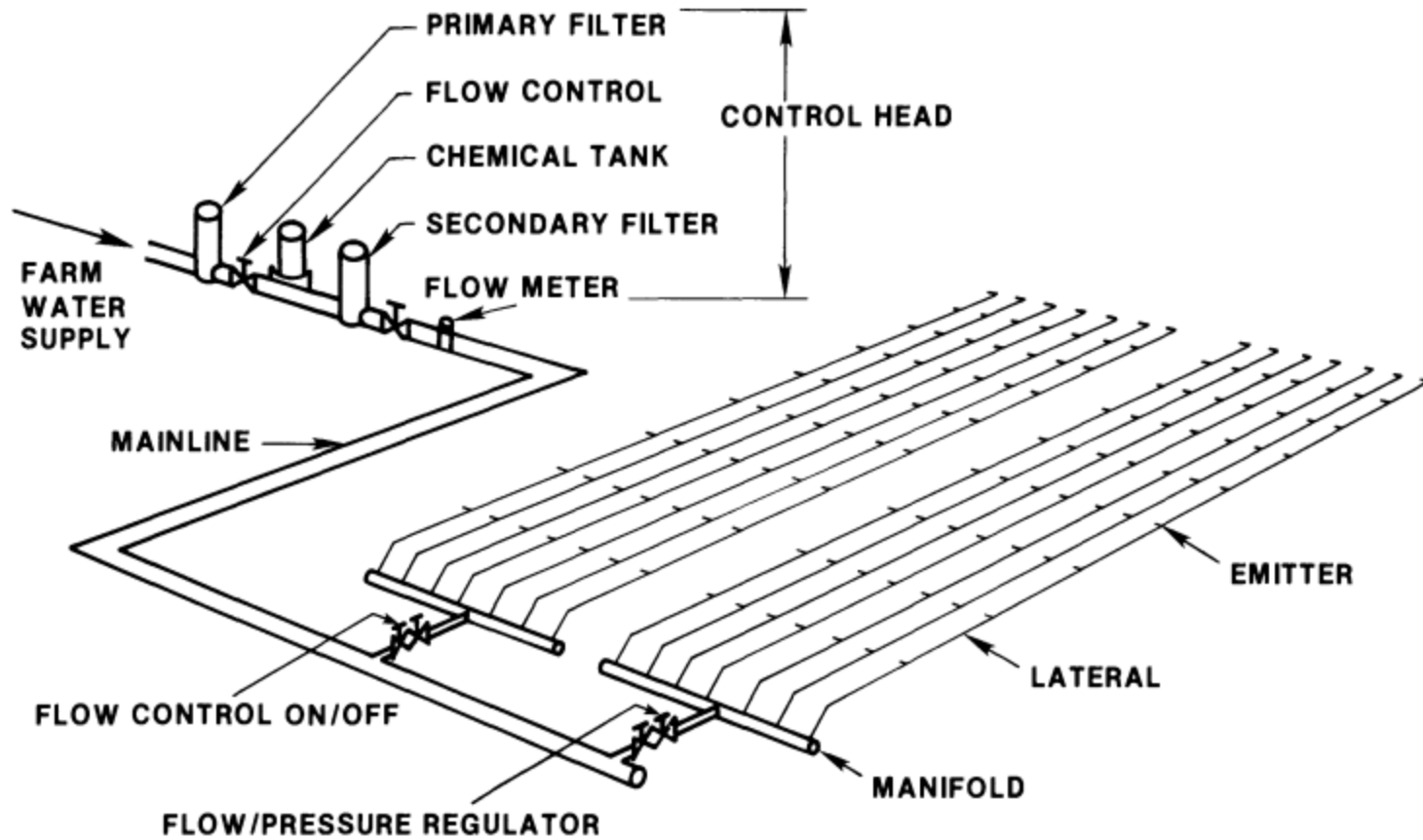

Basic components of a trickle irrigation system



Drip Irrigation

Assignment

What are the different types of filters used in drip irrigation system? Write about their working principle and purpose of use.



Drip Irrigation

- The pipe system is usually made of flexible PVC pipes. The emitters are also made of PVC materials
- They are not damaged when using with saline water or water mixed with fertilizers.

Types of Emitters

- Based on operating pressure
 - ✓ Low pressure(2 to 5m)
 - ✓ High pressure(8 to 15m)
- Based on discharge
 - ✓ Low (below 4 lph)
 - ✓ Medium (4 to 10 lph)
 - ✓ High (15 lph and above)





Drip Irrigation

Types of Emitters

- ❑ Based on principle of operation
 - ✓ Orifice
 - ✓ Long-path
 - ✓ Double wall pipe or perforated pipe
- ❑ Based on type of connection to lateral
 - ✓ In-line emitter
 - ✓ On-line emitter

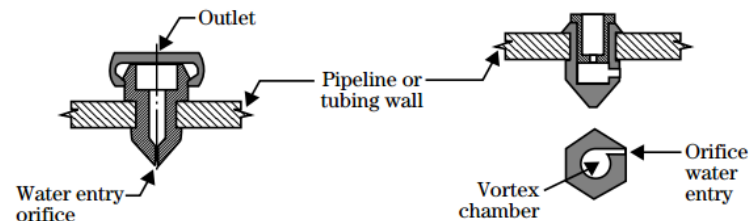

Orifice emitter

Orifice-vortex emitter

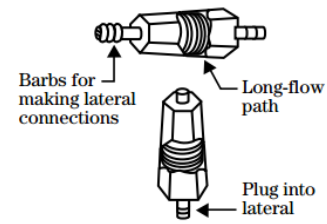

Long-path emitters

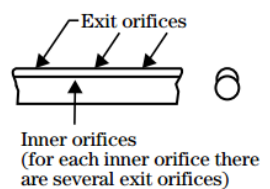

Twin-wall emitter lateral

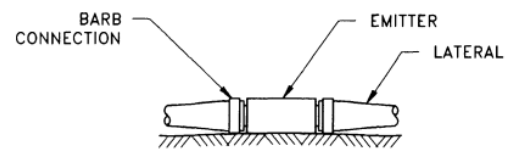

A. IN-LINE EMITTER

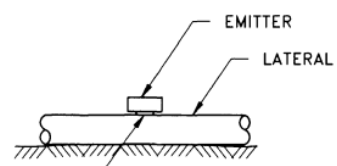

B. ON-LINE EMITTER

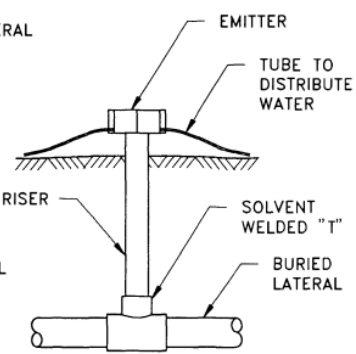

C. ON-LINE RISER WITH EMITTER

ASSIGNMENT

• DIFFERENCE BETWEEN:

1. In-line emitter
2. On-line emitter



Drip Irrigation

Advantages

✓ Water and cost saving:

It can irrigate crops with significantly less amount of water than is required by other irrigation methods. The cost of labour can be reduced, as the system can be completely automated.

✓ Easier field operation:

As it doesn't stimulate weed growth, requirement of weed control is very less. Also fertigation can be done using highly soluble fertilizers.

✓ Use of saline water:

Frequent irrigation maintains most of the soil in well aerated condition and at a soil moisture content that doesn't fluctuate between wet and dry extremes. Less drying between irrigations keeps the salts in the soil more dilute, making it possible to use more saline water.



Drip Irrigation

Advantages

- ✓ Use on rocky solids and steep slopes:

Rocky areas can be irrigated effectively even when the spacing is irregular, as water is applied close to the tree.

Disadvantages

- ✓ High cost
- ✓ Clogging
- ✓ Soil Condition (based on infiltration rate)
- ✓ Salt accumulation:

Salts often concentrate at soil surface and become a potential hazard, as light rains can leach them down-ward into root zone. Therefore, when rainfalls after a period of salt accumulation, irrigation should continue on schedule to leach those salts below root zone.

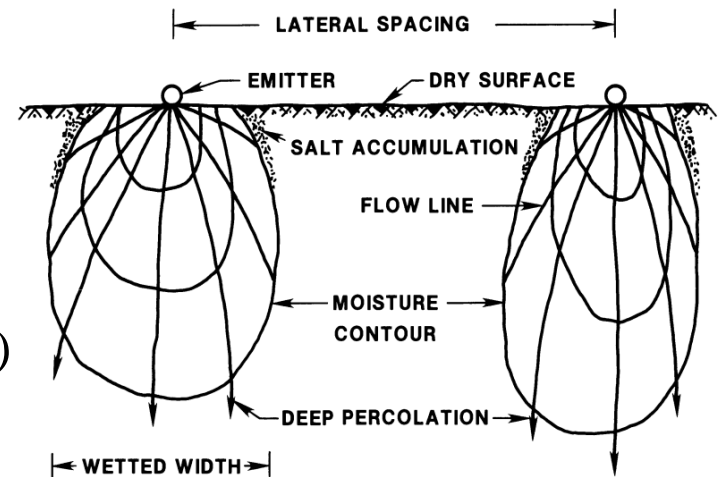



Sub-Irrigation

Water and nutrient solution provided at the base of the container rises by capillary action through holes in the bottom and is absorbed by the growing media.

Systems are adaptable to crops grown in pots.

Examples of sub-irrigation system:

1. Capillary mat system:

The pots are set on a mat that is kept constantly wet with nutrient solutions. The pots take up the solution through holes in the bottom. The mat is placed on a level bench over a layer of plastic.

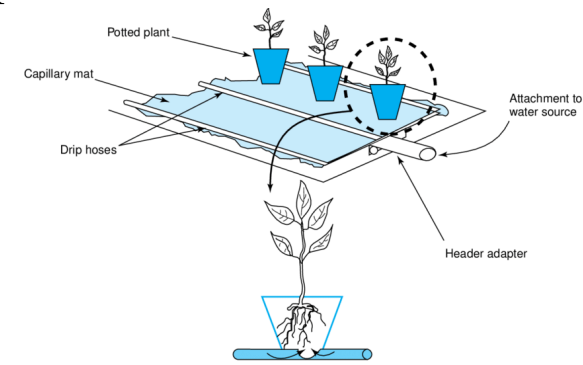



Sub-Irrigation

2. Trough System:

Plastic or metal troughs are placed on existing benches or supported overhead from the greenhouse structure. The troughs are installed at a slight slope (3” to 6” per 100’) from one end to the other. Pots are spaced along the trough. Nutrient solution is pumped to the high end, flows past the base of the pots and is collected in a cross gutter at the low end. The solution returns to a storage tank under the benches or below ground to be recycled.



Sub-Irrigation

3. Ebb and Flow benches:

- This system uses 4' to 6' wide watertight benches or water-tight movable trays to contain the nutrient solution.
- The benches, usually of plastic or fiberglass construction are installed perfectly level to maintain a uniform depth of liquid.
- They can be installed as either fixed or movable depending on the crops to be grown.
- Channels in the bottom of the bench allow the water to distribute evenly and to drain rapidly when the water supply is shut off.
- This allows the bench top to dry reducing algae growth and disease potential.

Ebb & Flow (Flood & Drain)

