

Friction

2.1 INTRODUCTION

Whenever the surfaces of two bodies are in contact, there is some resistance to sliding between them. The opposing force to the movement is called friction or force of friction. It is due to interlocking of surfaces as a result of the presence of some roughness and irregularities at the contact surfaces. The resisting force acts in the direction opposite to the movement. A force of friction comes into play whenever there is a relative motion between two parts. Some energy is wasted in order to overcome the resistance due to force of friction.

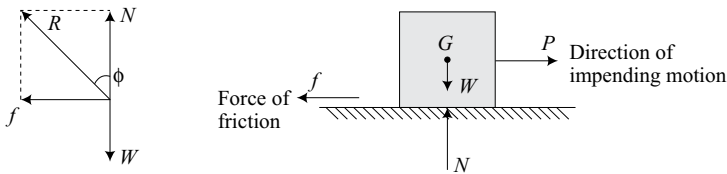

Fig. 2.1 Force of friction

Force of friction or frictional force is the opposing force to the movement of one body over the surface of another body.

In Fig. 2.1,

W = Weight of the body (mg)

N = Normal reaction

f = Friction force

P = Force applied to the body

R = Total reaction

ϕ = Angle of friction

2.1.1 Engineering Applications of Friction

Friction is both desirable and undesirable in engineering applications.

1. *Friction devices*: There are devices in engineering which work due to friction. Examples are lifting machines such as screw jack, power trans-

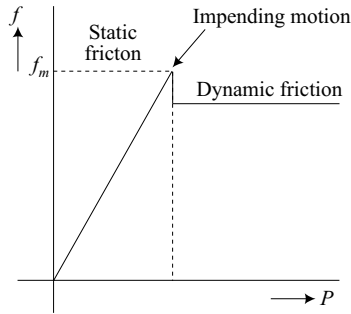

Fig. 2.3 Limiting friction

2.3.3 Important Definitions

(a) Angle of Friction

It is the angle made by the resultant (R) of the normal reaction (N) and limiting force of friction (f) and made with the direction of normal reaction.

R is the resultant of normal reaction N and force of friction f .

$$R = \sqrt{N^2 + f^2}$$

ϕ is the angle of friction

$$\tan \phi = \frac{f}{N}$$

or

$$\phi = \tan^{-1} \frac{f}{N}$$

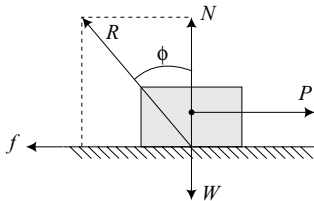

Fig. 2.4 Angle of friction

(b) Coefficient of friction

It is ratio of limiting frictional force and the normal reaction.

The coefficient of friction,

$$\mu = \frac{f}{N} = \tan \phi$$

\therefore

$$f = \mu N$$

μ depends upon the nature of contacting surface. Its value is very low for lubricated surfaces and high for dry friction.

(c) Angle of Repose

A body of weight W is lying on a rough plane inclined at an α with the horizontal. The body is in equilibrium under the action of following forces:

- (i) *Weight of the body W* . It has two components: $W \sin \alpha$ parallel to inclined plane and $W \cos \alpha$ normal to the plane.
- (ii) *Normal reaction, N* acting in a direction normal to inclined plane.
- (iii) *Friction force, f* acting in a direction opposite to the motion.

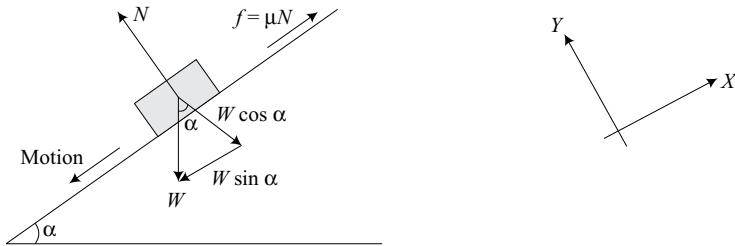

Fig. 2.5 Angle of repose

When the body tends to slide down the plane, the frictional force must act up the plane and when the body is being pulled up, the force of friction acts downwards to oppose the motion.

Selecting the reference coordinate system with X -axis in the direction of inclined plane and Y -axis perpendicular to inclined plane,

Applying equilibrium conditions,

$$\Sigma F_X = 0$$

$$f = W \sin \alpha$$

$$\Sigma F_Y = 0$$

$$N = W \cos \alpha$$

$$\therefore \frac{f}{N} = \frac{W \sin \alpha}{W \cos \alpha} = \tan \alpha$$

But,

$$\frac{f}{N} = \mu = \tan \phi$$

where ϕ is called the angle of friction.

resolved into rectilinear components. The unknown forces are found from the equations of equilibrium.

2.4.1 Rough Horizontal Plane

There can be following cases of motion of body on rough horizontal plane. The equilibrium conditions for each case are discussed.

(a) No moving force

$$P = 0$$

$$\therefore \text{Friction force, } f = 0$$

$$W = N$$

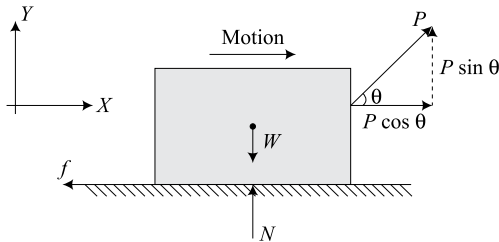

Fig. 2.7 Rough horizontal plane

(b) Body moving under pull or push

A force P is applied to the body. The force body diagram is shown.

Considering the equilibrium of the body.

$$\Sigma F_X = 0$$

$$P \cos \theta = f$$

But by definition, $f = \mu N$

$$\therefore P \cos \theta = \mu N \quad \dots(1)$$

$$\Sigma F_Y = 0$$

$$\therefore N = W \pm P \sin \theta$$

$$\therefore W = N + P \sin \theta$$

$$\text{or } N = W - P \sin \theta \quad \dots(2)$$

From equations (1) and (2)

$$P \cos \theta = \mu(W - P \sin \theta)$$

$$P \cos \theta + \mu P \sin \theta = \mu W$$

$$P \left(\cos \theta + \frac{\sin \phi}{\cos \phi} \sin \theta \right) = \frac{\sin \phi}{\cos \phi} W \quad \left[\because \mu = \tan \phi = \frac{\sin \phi}{\cos \phi} \right]$$

$$p(\cos \theta \cos \phi + \sin \theta \sin \phi) = W \sin \phi$$

$$P \cos (\theta - \phi) = W \sin \phi$$

$$P = \frac{W \sin \phi}{\cos (\theta - \phi)}$$

For P to be minimum, $\cos (\theta - \phi)$ should be maximum,

$$\therefore \cos (\theta - \phi) = 1$$

$$\theta = \phi$$

The angle of inclination of force P should be equal to the angle of friction, ϕ .

Example 2.1: The force required to pull the body of weight 50 N on a rough horizontal surface is 20 N where it is applied at an angle of 25° with the horizontal as shown. Determine the coefficient of friction and magnitude of reaction N between the body and the horizontal surface. Does the reaction pass through the centre of gravity of the body? [U.P.T.U. I Sem., 2002–03]

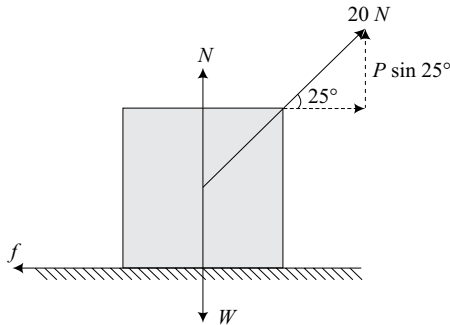

Solution: The body is in equilibrium

$$\therefore \Sigma F_y = 0$$

$$N = W - P \sin 25^\circ$$

$$= 50 - 20 \times 0.42$$

$$= 41.55 \text{ N}$$

$$\Sigma F_x = 0$$

$$\therefore f = 20 \cos 25^\circ = 18.13 \text{ N}$$

$$\text{Now, } \mu = \frac{f}{N} = \frac{18.13}{41.55} = \mathbf{0.436 \text{ Ans.}}$$

The reaction passes through the centre of gravity of the body as it is equal and opposite to weight of body W .

Example 2.2: A block of weight 5 kN is pulled by a force P as shown. The coefficient of friction between the contact surface is 0.35. Find the direction θ for which P is minimum and find the corresponding value of P .

[U.P.T.U. II Sem., 2003–04]

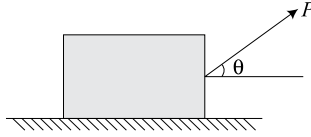

Solution:

- (i) Draw free body diagram of the block.
- (ii) Apply equilibrium conditions.

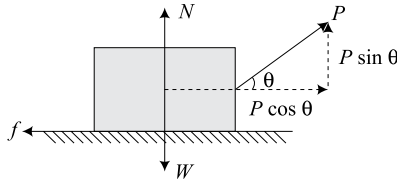

$$\Sigma F_x = 0$$

$$f = P \cos \theta$$

$$\Sigma F_y = 0$$

$$W = N + P \sin \theta$$

- (iii) The angle of inclination of force P will be equal to the angle of friction for minimum value of P .

$$\begin{aligned} \therefore \theta &= \phi = \tan^{-1} \mu = \tan^{-1} 0.35 \\ &= 20.48^\circ \end{aligned}$$

$$P = \frac{W \sin \phi}{\cos (\theta - \phi)}$$

For P to be minimum, $\cos (\theta - \phi) = 1$

$$\therefore P = W \sin \phi = 5 \sin 20.48^\circ = \mathbf{1.75 \text{ kN}} \quad \text{Ans.}$$

Example 2.3: Obtain the expression for minimum force required to drag a body on a rough horizontal plane.

Solution:

- (i) Draw free body diagram.
- (ii) Apply equilibrium conditions.

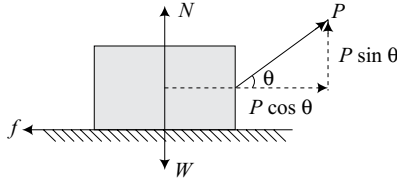

$$\Sigma F_x = 0$$

$$\therefore f = P \cos \theta = \mu N \quad \dots(1)$$

$$\Sigma F_y = 0$$

$$N = W + P \cos \theta \quad \dots(2)$$

From equations (1) and (2)

$$P \cos \theta = \mu N$$

$$= \mu(W - P \sin \theta)$$

$$P \cos \theta + \mu P \sin \theta = \mu W$$

Now,
$$\mu = \tan \phi = \frac{\sin \phi}{\cos \phi}$$

$$P \left(\cos \theta + \frac{\sin \phi}{\cos \phi} \sin \theta \right) = \frac{\sin \phi}{\cos \phi} \cdot W$$

$$P(\cos \theta \cos \phi + \sin \theta \sin \phi) = W \sin \phi$$

$$P \cos(\theta - \phi) = W \sin \phi$$

$$P = \frac{W \sin \phi}{\cos(\theta - \phi)}$$

For P to be minimum, $\cos(\theta - \phi)$ should be maximum

$$\therefore \cos(\theta - \phi) = 1$$

$$\theta = \phi$$

Minimum value of $P = W \sin \phi$

or
$$= W \sin \theta \quad \text{Ans.}$$

2.4.2 Rough Inclined Plane

(a) Equilibrium Condition for Different Angle of Inclination

(i) Angle of inclination less than angle of friction

1. Draw free body diagram.
2. Apply equilibrium conditions.

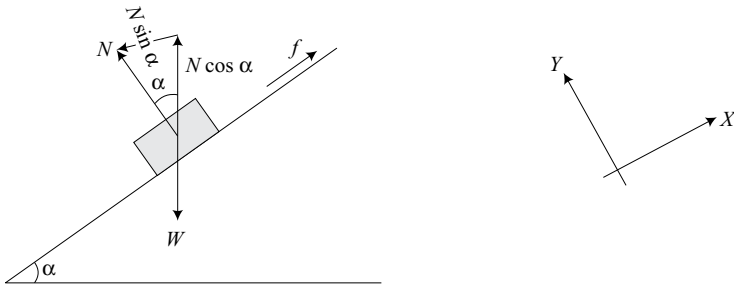

Fig. 2.8 Rough inclined plane ($\alpha < \phi$)

$$\Sigma F_x = 0$$

$$f = \mu N = N \sin \alpha$$

$$\Sigma F_y = 0$$

$$W = N \cos \alpha$$

The body is in equilibrium.

(i) Angle of inclination more than angle of friction.

The body will slide down and an upward force P is required to restrict the body from moving down. The restricting force can be applied in different ways.

1. *Along the inclined plane*

Draw free body diagram.

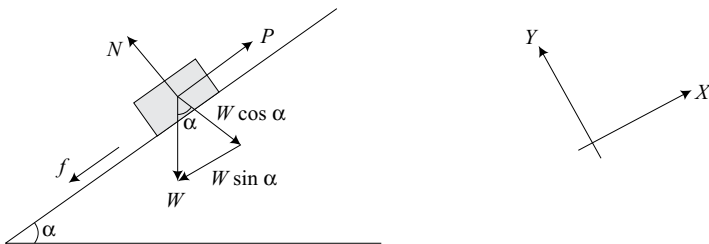

Fig. 2.9 Force parallel to inclined plane

Equilibrium conditions.

$$\Sigma F_x = 0$$

$$f = P - W \sin \alpha$$

$$\Sigma F_y = 0$$

$$N = W \cos \alpha$$

2. *The restricting force applied horizontally*

Draw free body diagram.

Apply equilibrium condition.

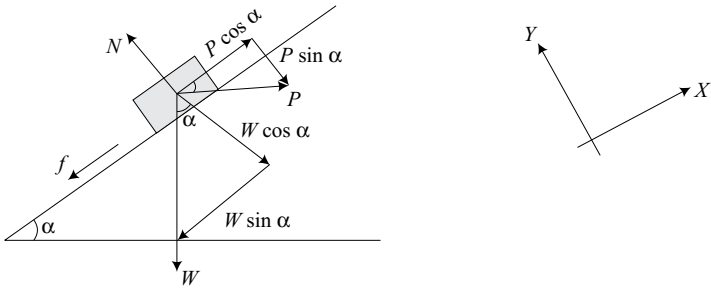

Fig. 2.10 Force applied horizontally

$$\Sigma F_x = 0$$

$$f = P \cos \alpha - W \sin \alpha$$

$$\Sigma F_y = 0$$

$$N = W \cos \alpha + P \sin \alpha$$

3. Force applied at an angle θ with the inclined plane

Draw free body diagram.

Apply equilibrium conditions.

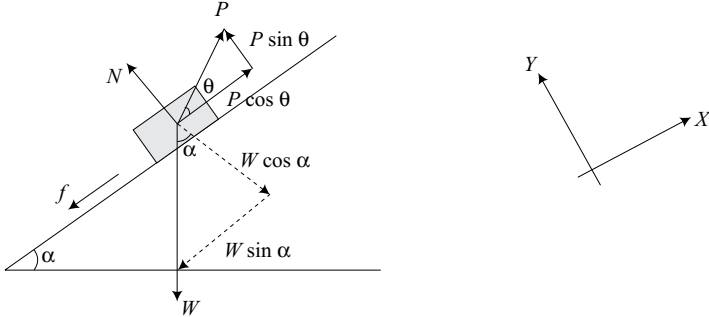

Fig. 2.11 Force applied at an angle θ with plane

$$\Sigma F_x = 0$$

$$f = P \cos \theta - W \sin \alpha$$

$$\Sigma F_y = 0$$

$$N = W \cos \alpha - P \sin \theta$$

(b) Body sliding downwards

A body of weight W is on the verge of sliding downwards. A minimum force P is required to restrict the motion.

(i) Draw free body diagram.

(ii) Apply equilibrium conditions.

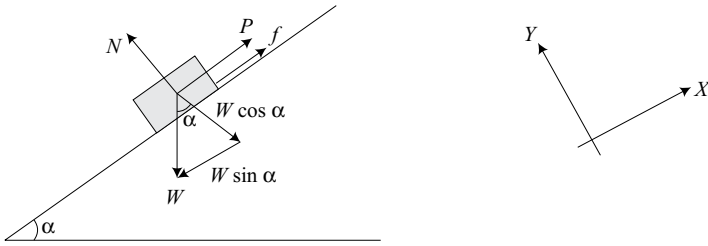

Fig. 2.12 Body sliding downwards

$$\Sigma F_x = 0$$

$$f = \mu N = W \sin \alpha - P$$

$$\therefore P = W \sin \alpha - \mu N \quad \dots(1)$$

$$\Sigma F_y = 0$$

$$N = W \cos \alpha$$

$$\dots(2)$$

From equations (1) and (2)

$$P = W \sin \alpha - \mu(W \cos \alpha)$$

$$= W(\sin \alpha - \mu \cos \alpha)$$

$$= W \left(\sin \alpha - \frac{\sin \phi}{\sin \theta} \cos \alpha \right)$$

$$\therefore \mu = \tan \phi = \frac{\sin \phi}{\cos \phi}$$

$$P \cos \phi = W(\sin \alpha \cos \phi - \cos \alpha \cos \phi)$$

$$\therefore P = \frac{W \sin(\alpha - \phi)}{\cos \phi}$$

(c) Body upwards an inclined plane

Minimum force required to keep the body in equilibrium.

(i) Draw free body diagram.

(ii) Apply equilibrium conditions.

$$\Sigma F_x = 0$$

$$f = P - W \sin \alpha$$

$$\therefore P = W \sin \alpha + f = W \sin \alpha + \mu N \quad \dots(1)$$

$$\Sigma F_y = 0$$

$$N = W \cos \alpha$$

$$\dots(2)$$

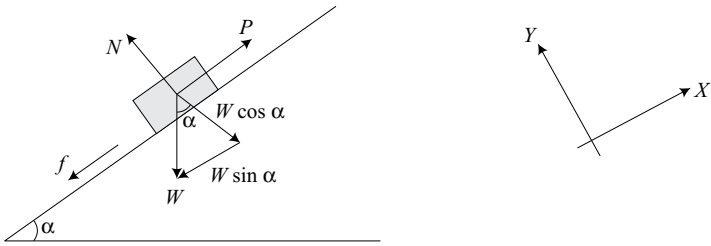

Fig. 2.13 Body upwards an inclined plane

From equations (1) and (2)

$$P = W \sin \alpha + \mu W \cos \alpha$$

$$= W \sin \alpha + \frac{\sin \phi}{\cos \phi} W \cos \alpha \quad \left[\mu = \tan \phi = \frac{\sin \phi}{\cos \phi} \right]$$

$$P \cos \phi = W \sin \alpha \cos \phi + W \sin \phi \cos \alpha$$

$$= W \sin (\alpha + \phi)$$

$$\therefore P = \frac{W \sin (\alpha + \phi)}{\cos \phi}$$

Example 2.4: A body of weight 500 N is pulled up along an inclined plane having an inclination of 30° with the horizontal. If the coefficient of friction between the body and the plane is 0.3 and the force is applied parallel to inclined plane, determine the force required. [U.P.T.U. II Sem., 2005–06]

Solution:

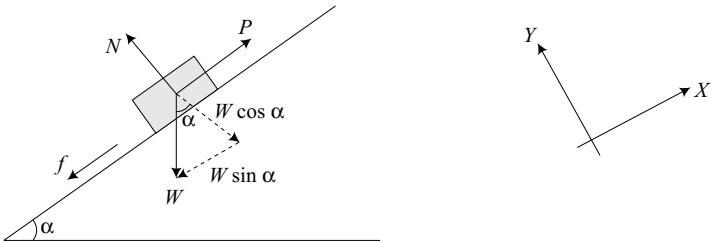

$$W = 500 \text{ N}$$

$$\alpha = 30^\circ$$

$$\mu = 0.3$$

Angle of friction,

$$\phi = \tan^{-1} \mu = \tan^{-1} 0.3 = 16.7^\circ$$

The force of friction will be acting downwards as the body is tending to move upwards.

Draw free body diagram and apply equilibrium conditions.

$$\Sigma F_x = 0$$

$$P - \sin \alpha = f = \mu N$$

$$\therefore P = W \sin \alpha + \mu N \quad \dots(1)$$

$$\Sigma F_y = 0$$

$$N = W \cos \alpha \quad \dots(2)$$

From equations (1) and (2)

$$\begin{aligned} P &= W \sin \alpha + \mu W \cos \alpha \\ &= 500 \sin 30^\circ + 0.3 \times 500 \cos 30^\circ \\ &= 250 \times 0.5 + 0.3 \times 500 \times 0.866 \\ &= 250 + 129.9 = \mathbf{379.9 \text{ N}} \quad \text{Ans.} \end{aligned}$$

Example 2.5: A body of weight W is placed on a rough inclined plane having inclination α to the horizontal. The force P is applied horizontal to drag the body. If the body is on the point of motion up the plane, prove that P is given by:

$$P = W \tan (\alpha + \phi)$$

where, ϕ = angle of friction.

Solution: Draw free body diagram and apply equilibrium conditions.

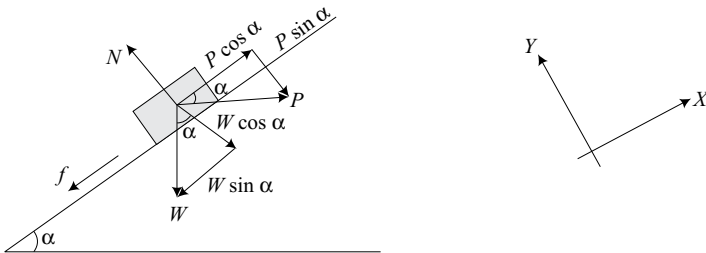

$$\Sigma F_x = 0$$

$$P \cos \alpha = W \sin \alpha + f = W \sin \alpha + \mu N \quad \dots(1)$$

$$\Sigma F_y = 0$$

$$N = W \cos \alpha + P \sin \alpha \quad \dots(2)$$

From equations (1) and (2)

$$\begin{aligned} P \cos \alpha &= W \sin \alpha + \mu (W \cos \alpha + P \sin \alpha) \\ &= W \sin \alpha + \mu W \cos \alpha + \mu P \sin \alpha \\ P \cos \alpha - \mu P \sin \alpha &= W \sin \alpha + \mu W \cos \alpha \end{aligned}$$

$$\therefore P = W \frac{\sin \alpha + \mu \cos \alpha}{\cos \alpha - \mu \cos \alpha}$$

But, $\mu = \tan \phi$ (By definition)

$$\begin{aligned} \therefore P &= W \frac{\sin \alpha + \tan \phi \cos \alpha}{\cos \alpha - \tan \phi \sin \alpha} \\ &= W \frac{\sin \alpha \cos \phi + \sin \phi \cos \alpha}{\cos \alpha \cos \phi - \sin \alpha \sin \phi} \\ &= W \frac{\sin (\alpha + \phi)}{\cos (\alpha + \phi)} \end{aligned}$$

$$\therefore P = W \tan (\alpha + \phi) \quad \text{Proved.}$$

Example 2.6: A four wheel drive car as shown has a mass of 2000 kg with passengers. The roadway is inclined at an angle θ with the horizontal. If the coefficient of friction between tyres and road is 0.3, what is the maximum inclination θ that can be climbed?

Solution: Draw free body diagram as shown. The wheels are rotating clockwise to climb the roadway, the forces of friction on the front wheel and rear wheel f_F and f_R will be acting upwards to oppose the direction of motion of the wheel.

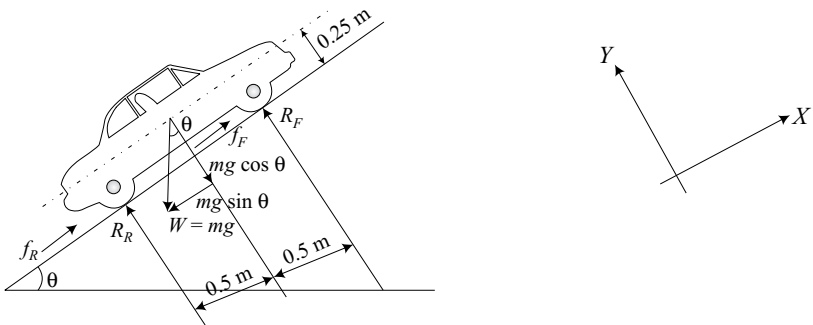

Apply equilibrium conditions,

$$\Sigma F_x = 0$$

$$\begin{aligned} \therefore f_R + f_F &= mg \sin \theta \\ &= 2000 + 9.81 \sin \theta \\ &= 19620 \sin \theta \text{ (N)} \end{aligned}$$

$$\Sigma F_y = 0$$

$$\begin{aligned} R_R + R_F &= mg \cos \theta \\ &= 2000 \times 9.81 \cos \theta \\ &= 19620 \cos \theta \text{ (N)} \end{aligned}$$

$$\text{But, } f_R = \mu R_R$$

$$\text{and } f_F = \mu R_F$$

$$\therefore f_R + f_F = \mu(R_R + R_F)$$

$$19620 \sin \theta = \mu(R_R + R_F)$$

$$\begin{aligned} \therefore R_F + R_R &= \frac{19620 \sin \theta}{0.3} = 65400 \sin \theta \\ &= 19620 \cos \theta \end{aligned}$$

$$\therefore \frac{\sin \theta}{\cos \theta} = \frac{19620}{65400} = 0.3$$

$$\therefore \theta = 16.7^\circ$$

2.4.3 Ladder Friction

A ladder is placed against a rough wall and a rough floor with coefficient of friction μ_2 and μ_1 respectively.

Example: A ladder, AB of length L and of weight W is placed against a rough wall and rough floor. The reactions R_A and R_B will be acting perpendicular to the point of supports at floor and wall. The ladder has tendency to slide down. Therefore, the forces of friction f_A and f_B will be acting to oppose the motion.

Draw free body diagram of ladder and apply conditions of equilibrium.

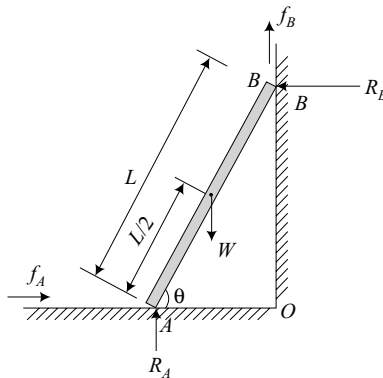

Fig. 2.14 Ladder friction

$$\Sigma F_x = 0 \quad \therefore f_A = R_B$$

$$\Sigma F_y = 0 \quad W = R_A + f_B$$

The number of unknowns are four. Therefore, take moments about point O .

$$\Sigma M_O = 0$$

Example 2.7: A uniform ladder of weight 300 N rests against a smooth vertical wall a rough horizontal floor making an angle 60° with the horizontal. Find the force of friction at floor. [U.P.T.U. I/II Sem., 2001–02]

Solution: Draw free body diagram of ladder AB and apply condition of equilibrium.

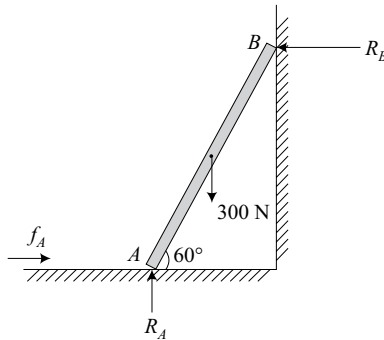

As the wall is smooth, $f_B = 0$.

$$\Sigma F_x = 0$$

$$\therefore f_A = R_B$$

$$\mu R_A = R_B$$

$$\Sigma F_y = 0$$

$$R_A = W = 300 \text{ N}$$

$$\therefore f_A = \mu R_A = 300\mu$$

Assume $\mu = 0.3$ between ladder and floor.

The force of friction,

$$f_A = 0.3 \times 300 = \mathbf{90 \text{ N}} \quad \mathbf{Ans.}$$

Example 2.8: A uniform ladder of length 10 m and weighing 20 N is placed against a smooth vertical wall with its lower end 8 m from the wall. In this position the ladder is just to slip. Determine:

(i) Coefficient of friction between ladder and floor.

(ii) Frictional force acting on the ladder at the point of contact between the ladder and floor. [U.P.T.U. I Sem., 2004–05]

Solution: Draw free body diagram of ladder.

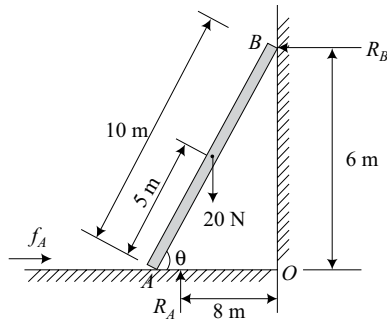

Angle of inclination,

$$\cos \theta = \frac{8}{10} = 0.8$$

$$\therefore \theta = 36.87^\circ$$

$$\sin \theta = 0.6$$

Applying equilibrium conditions,

$$\Sigma F_x = 0$$

$$\therefore f_A = R_B$$

$$\Sigma F_y = 0$$

$$R_A = W = 20 \text{ N} \quad (\because f_B = 0)$$

$$\Sigma M_O = 0$$

$$R_A \times 8 = 20 \times 4 + R_B \times 6$$

$$R_B = \frac{R_A \times 8 - 20 \times 4}{6} = \frac{20 \times 8 - 20 \times 4}{8}$$

$$= 10 \text{ N}$$

Force of friction, $f_A = R_B = 10 \text{ N}$

$$\mu = \frac{R_B}{N} = \frac{10}{20} = 0.5 \quad \text{Ans.}$$

Example 2.9: A ladder of length ' l ' rests against a wall, the angle of inclination being 45° . If the coefficient of friction between the ladder and the ground and that between the ladder and the wall is 0.5 each, what will be the maximum distance on ladder to which a man whose weight is 1.5 times the weight of the ladder may ascend before the ladder begins to slide? [U.P.T.U. I Sem., 2005–06]

Solution: Draw free body diagram as shown and apply equilibrium conditions.

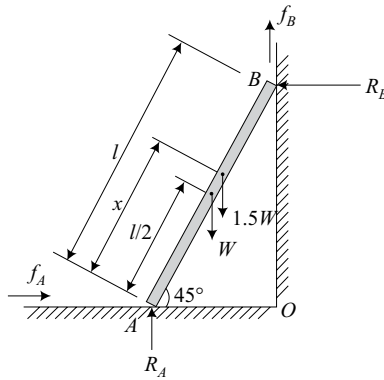

(i) $\Sigma F_x = 0$

$$f_A = R_B = \mu N = \mu R_A$$

$$= 0.5 R_A$$

$\therefore R_A = 2 R_B$

(ii) $\Sigma F_y = 0$

$$R_A + f_B = W + 1.5W = 2W$$

$$R_A = 2R_B$$

$$f_B = \mu R_B = 0.5 R_B$$

$\therefore 2R_B + 0.5R_B = 2W$

$$R_B = \frac{2}{2.5} W = 0.8 W$$

$\therefore f_B = 0.5R_B = 0.4 W$

(iii) $\Sigma M_A = 0$

$$W \times \frac{l}{2} \cos 45^\circ + 1.5W x \cos 45^\circ = R_B \times l \sin 45^\circ + f_B l \cos 45^\circ$$

$$= 0.8 W l \sin 45^\circ + 0.4 W l \cos 45^\circ$$

$$0.353 Wl + 1.06 Wx = 0.5656 Wl + 0.2828 Wl$$

$$1.06x = (0.5656 + 0.2828 - 0.353)l = 0.49544l$$

$\therefore \frac{x}{l} = \frac{0.49544}{1.06} = 0.467$

The man can ascend 46.7% of ladder length.

Example 2.10: A uniform ladder of weight 800 N and length 7 m rests on a horizontal ground and leans against a smooth vertical wall. The angle made by the ladder with the horizontal is 60° . When a man of weight 600 N stands on the ladder 4 m from the top of the ladder, the ladder is at the point of slipping. Determine the coefficient of friction between the ladder and the floor.

Solution: Draw free body diagram of the ladder and apply equilibrium conditions.

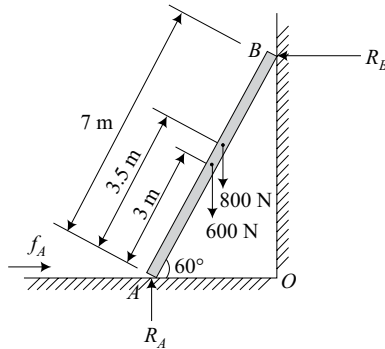

$$(i) \quad \Sigma F_x = 0$$

$$f_A = R_B$$

$$(ii) \quad \Sigma F_y = 0$$

$$R_A = 800 + 600 = 1400 \text{ N}$$

$$\therefore \quad f_A = R_B = \mu N = \mu R_A \\ = 1400\mu$$

$$(iii) \quad \Sigma M_B = 0$$

$$R_A \times 7 \cos 60^\circ = f_A \times 7 \sin 60^\circ + 800 \times 3.5 \cos 60^\circ + 600 \times 3 \cos 60^\circ \\ 1400 \times 7 \cos 60^\circ = 1400\mu \times 7 \sin 60^\circ + (800 \times 3.5 + 600 \times 3) \cos 60^\circ$$

$$\therefore \quad \mu = \frac{1400 \times 7 \cos 60^\circ - 4600 \cos 60^\circ}{1400 \times 7 \sin 60^\circ} \\ = \frac{4900 - 2300}{8487} = 0.3 \quad \text{Ans.}$$

2.4.4 Wedge Friction

A wedge is used to lift loads vertically by applying horizontal force. These are made in triangular or trapezoidal shape. It works on the principle of inclined

plane. A wedge of angle α is pushed under a block of weight W by applying a force P horizontally. The solution consists of finding the value P .

1. Draw free body diagram of block (Fig. 2.16). The frictional force f_1 , between block and wall will act downwards to oppose the motion of block moving upwards. The frictional force f_2 , between block and wedge will act downwards of inclined plane of block to oppose the motion. The reactions N_1 and N_2 will act normal to the supporting surface. R_1 and R_2 are the resultants of N_1, f_1 and N_2, f_2 respectively. ϕ is the angle of limiting friction.

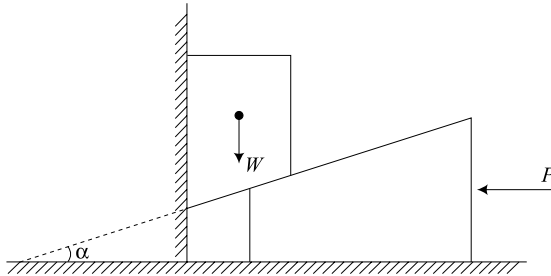

Fig. 2.15 Wedge friction

2. Apply equilibrium conditions.

(i) $\Sigma F_x = 0$

$$R_1 \cos \phi - R_2 \sin (\alpha + \phi) = 0 \quad \dots(1)$$

(ii) $\Sigma F_y = 0$

$$R_1 \sin \phi + W - R_2 \cos (\alpha + \phi) = 0 \quad \dots(2)$$

Calculate R_2 from equations (1) and (2).

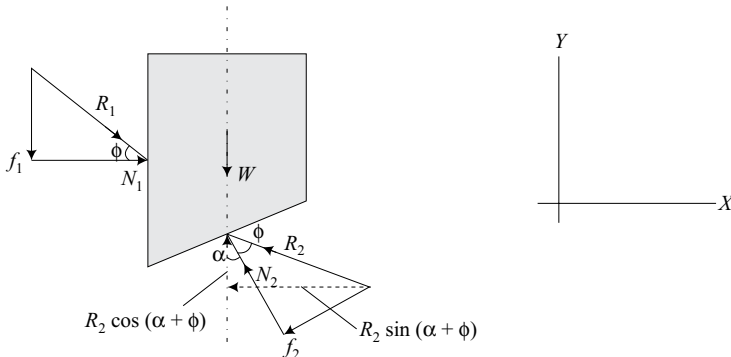

Fig. 2.16 FBD of block

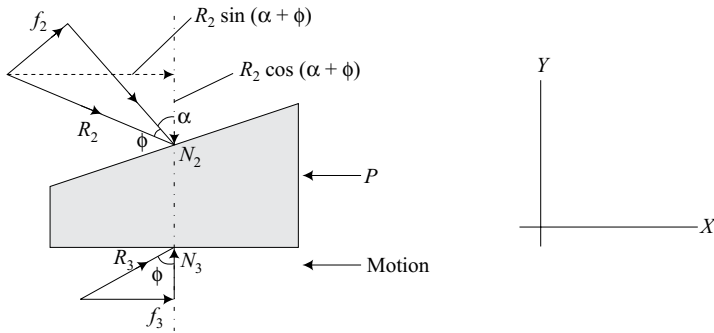

Fig. 2.17 FBD of wedge

- Draw free body diagram of wedge (Fig. 2.17). The reactions $N_2' = -N_2$ and frictional force f_2 will be equal to frictional force acting on block but in opposite direction. Reactions N_2' and N_3 will be acting normal to supporting surfaces.
- Apply equilibrium conditions to the wedge.

$$(i) \quad \Sigma F_x = 0$$

$$R_2 \sin(\alpha + \phi) + R_3 \sin \phi - P = 0 \quad \dots(3)$$

$$(ii) \quad \Sigma F_y = 0$$

$$R_3 \cos \phi - R_2 \cos(\alpha + \phi) = 0 \quad \dots(4)$$

Solve equations (3) and (4) simultaneously to find P.

Example 2.11: A block weighing 1500 N, over laying a 10° wedge on a horizontal floor leaning against a vertical wall, is to be raised by applying a horizontal force to the wedge. Assuming the coefficient of friction between all surfaces in contact to be 0.3, determine the minimum horizontal force.

Solution:

- Draw free body diagram for block (Fig. 2.16), and apply equilibrium conditions.

$$(i) \quad \Sigma F_x = 0$$

$$R_1 \cos \phi - R_2 \sin(\alpha + \phi) = 0$$

$$W = 1500 \text{ N}$$

$$\alpha = 10^\circ$$

$$\mu = \tan \phi = 0.3$$

$$\phi = 16^\circ 42'$$

$$\therefore R_1 \cos 16^\circ 42' - R_2 \sin(10^\circ + 16^\circ 42') = 0$$

$$\therefore R_2 = 2.132 R_1$$

(ii) $\Sigma F_y = 0$

$$-R_1 \sin \phi - W + R_2 \cos (\alpha + \phi) = 0$$

$$-R_1 \sin 16^\circ 42' - 1500 + 2.13 R_1 \cos (10^\circ + 16^\circ 42') = 0$$

$\therefore R_1 = 927.3 \text{ N}$

$$R_2 = 2.132 R_1 = 1997 \text{ N}$$

2. Draw free body diagram of wedge (Fig. 2.17) and apply equilibrium conditions.

(i) $\Sigma F_x = 0$

$$R_2 \sin (\alpha + \phi) + R_3 \sin \phi - P = 0$$

(ii) $\Sigma F_y = 0$

$$R_3 \cos \phi - R_2 \cos (\alpha + \phi) = 0$$

$$R_3 \cos 16^\circ 42' - 1977 \cos (10^\circ + 16^\circ 42') = 0$$

$\therefore R_3 = 1844 \text{ N}$

$\therefore P = R_2 \sin (\alpha + \phi) + R_3 \sin \phi$

$$= 1977 \sin (10^\circ + 16^\circ 42') + 1844 \sin 16^\circ 42'$$

$$= \mathbf{1418.3 \text{ N} \quad \text{Ans.}}$$

2.4.5 Belt Friction

Power is transmitted from one shaft to another by friction between the belt and the pulleys on which it passes. The driving pulley pulls the belt from one side and delivers the same to the other. The tension T_1 on tight side is more than T_2 on slack side.

If T_1 = Tension in belt on tight side, [N]

T_2 = Tension in belt on slack side, [N]

v = Velocity of the belt, [m/s]

r = Radius of the pulley, [m]

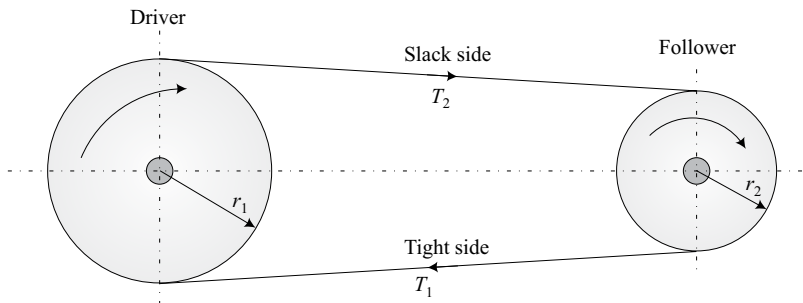

Fig. 2.18 Belt drive

$$\text{Torque transmitted} = (T_1 - T_2)r \text{ [N - m]}$$

$$\text{Work done} = \text{Force} \times \text{Distance} = (T_1 - T_2)v \text{ [Nm/s]}$$

$$\text{Power transmitted} = (T_1 - T_2)v \text{ [W]}$$

Example 2.12: Find expression for the following due to belt friction in a pulley drive.

- (i) Tension in the belt on tight and slack side.
- (ii) Torque transmitted.
- (iii) Reaction on the bearing of the pulley.

Solution: The belt and pulley system is shown in Fig. 2.19. The pulley is rotating in clockwise direction with angular velocity ω .

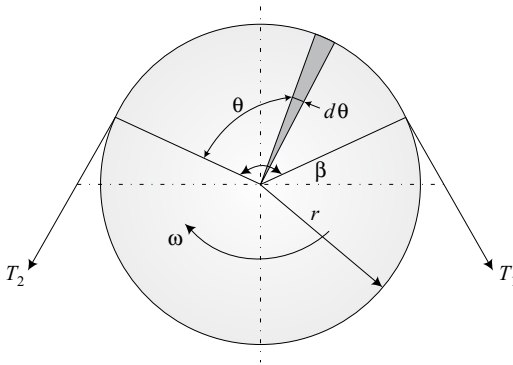

Fig. 2.19 Belt-pulley system

$$T_1 > T_2$$

r = Radius of pulley [m]

ω = Angular velocity [rad/s]

β = Angle of wrap of the belt over pulley.

Consider a small segment of belt of subtended angle $d\theta$ at an angle θ .

Draw free body diagram of segment of belt as shown in Fig. 2.20.

T = Tension in the belt segment on slack side

$T + dT$ = Tension in belt segment on tight side

dN = Normal reaction at the pulley rim.

$d\theta$ = Angle of embrace.

f = Frictional force

$$= \mu dN$$

μ = Coefficient of friction between belt and pulley.

$$\therefore \frac{T_1}{T_2} = 2.566$$

$$\therefore T_2 = \frac{T_1}{2.566} = \frac{3}{2.566} = 1.169 \text{ N}$$

$$\begin{aligned} \text{Torque} &= (T_1 - T_2)r \\ &= (3 - 1.169)0.5 = \mathbf{0.9155 \text{ N-m}} \quad \text{Ans.} \end{aligned}$$

Example 2.14: A belt drives a pulley of 200 mm diameter such that the ratio of tension in tight side and slack side is 1.2. If the maximum tension in the belt is not to exceed 240 kN. Find the safe power transmitted by the pulley at 60 rpm.

Solution: The maximum tension in the belt, $T_1 = 240 \text{ kN}$.

$$\frac{T_1}{T_2} = 1.2$$

$$\therefore T_2 = \frac{240}{1.2} = 200 \text{ kN}$$

$$\text{Speed of belt, } V = \frac{\pi d N}{60} = \pi \times \left(\frac{200}{1000} \right) \times \frac{60}{60} = 0.628 \text{ m/s}$$

$$\begin{aligned} \therefore \text{Power transmitted, } P &= (T_1 - T_2)V = (240 - 200)0.628 \\ &= \mathbf{25 \text{ kW}} \quad \text{Ans.} \end{aligned}$$

Example 2.15: A belt 100 mm wide and 8.0 mm thick is transmitting power at a belt speed of 160 m/min. The angle of lap of smaller pulley is 165° and coefficient of friction is 0.3. The maximum permissible stress in the belt is 2 MN/m^2 and mass of belt is 0.9 kg/m . Find the power transmitted and the initial tension in the belt.

Solution: The data given is:

$$b = 100 \text{ mm} = 0.1 \text{ m}$$

$$t = 8 \text{ mm} = 0.008 \text{ m}$$

$$V = 160 \text{ m/min} = \frac{160}{60} = 2.667 \text{ m/sec}$$

$$\beta = 165^\circ \times \frac{\pi}{180} = 2.88 \text{ rad}$$

$$\mu = 0.3$$

$$m = 0.9 \text{ kg/m}$$

$$T_1 = 3.454 \text{ kN}$$

$$T_2 = 4.8 - 3.454 = 1.346 \text{ kN}$$

$$\text{Max. torque} = (T_1 - T_2) \frac{D}{2} = (3.454 - 1.346) \frac{D}{2} = \mathbf{1.054D \text{ kN.m} \quad \text{Ans.}}$$

Example 2.17: A horizontal drum of a belt drive carries the belt over a semi-circle around it. It is rotated anticlockwise to transmit a torque of 300 N-m. If coefficient of friction between the belt and drum is 0.3, calculate the tension in the limbs 1 and 2 of the belt shown, and the reaction on the bearings. The drum has a mass of 20 kg and the belt is assumed to be massless.

[U.P.T.U. I Sem., 2001–02]

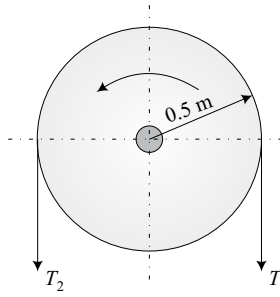

Solution:

$$T_2 > T_1 \text{ given}$$

$$\beta = \pi$$

$$\mu = 0.3$$

$$\therefore \frac{T_2}{T_1} = e^{\mu\beta} = e^{0.3\pi} = 2.566$$

$$T_2 = 2.566 T_1$$

$$\text{Torque} = (T_2 - T_1)r$$

$$300 = (2.566 T_1 - T_1) \times 0.5$$

$$T_1 = 383 \text{ N}$$

$$T_2 = 2.566 T_1 = 983 \text{ N}$$

$$\text{Reaction on the bearing} = T_1 + T_2 + mg = 383 + 983 + 20 \times 9.81$$

$$= \mathbf{1562.2 \text{ N} \quad \text{Ans.}}$$

Example 2.18: A 100 N weight is on the verge of sliding downwards. It is prevented by a weight W as shown. The coefficient of friction between rope and the fixed pulley, and between other surfaces of contact $\mu = 0.3$. Determine the minimum weight W to prevent the downward motion of 100 N body.

[U.P.T.U. I Sem., 2001–02]

$$\begin{aligned} \therefore N_2 &= N_1 + 100 \cos \alpha = 0.8W + 80 \\ f_2 &= \mu N_2 = 0.3(0.8W + 80) \\ &= 0.24W + 24 \end{aligned}$$

$$(ii) \Sigma F_x = 0$$

$$\begin{aligned} f_1 + f_2 - 100 \sin \alpha + T_2 &= 0 \\ 0.24W + (0.24W + 24) - 100 \times 0.6 + 1.575W &= 0 \\ 2.55W &= 36 \end{aligned}$$

$$\therefore W = 17.5 \text{ N} \quad \text{Ans.}$$

2.4.6 Screw Friction

The friction in the screw threads is widely used for fastening of components in machines and structures. The fasteners such as studs, bolts, nuts and screws are very widely used. Screw friction is also used in the design of lifting machines. Square threads are used in screw jack which is a machine used for raising/lifting of heavy loads by applying a small effort. The screw jack works on the principle of inclined plane. The load W is placed on the head of screw jack which is rotated by application of effort P at the end of a lever for lifting or lowering of load. In one revolution the head moves through a distance, p which is the pitch of the screw. In case of multi-start screw, the distance moved is np where n is the number of starts. The inclination of the thread, α can be found out as:

$$\tan \alpha = \frac{p}{\pi d_m}$$

where, d_m = mean diameter of the thread

α = angle of helix.

The effort required can be found out from the principle of inclined plane.

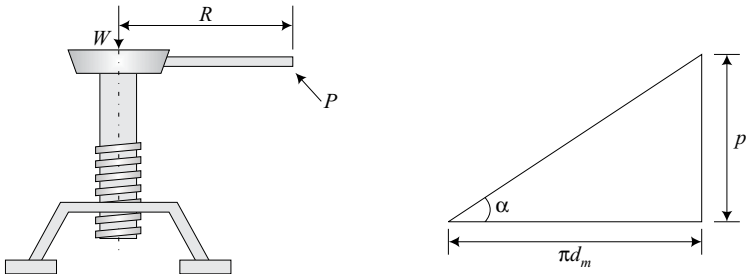

Fig. 2.21 Screw jack

$$1 - \eta = \frac{\sin(\alpha + \phi - \alpha)}{\cos \alpha \sin(\alpha + \phi)} = \frac{\sin \phi}{\cos \alpha \sin(\alpha + \phi)}$$

$$= \frac{2 \sin \phi}{2 \cos \alpha \sin(\alpha + \phi)}$$

But, $2 \cos A \sin B = \sin(A + B) + \sin(A - B)$

$$\therefore 1 - \eta = \frac{2 \sin \phi}{\sin(2\alpha + \phi) + \sin \phi}$$

For efficiency to be maximum, $1 - \eta$ should be minimum.

$\therefore 2 \sin(2\alpha + \phi)$ should be maximum.

$$\therefore (2\alpha + \phi) = 90^\circ$$

$$2\alpha = 90^\circ - \phi$$

$$\alpha = \left(45^\circ - \frac{\phi}{2}\right) \quad \text{Ans.}$$

This is the condition for maximum efficiency of screw jack.

Example 2.20: Show that maximum efficiency of a screw jack is given by

$$\eta_{\max} = \frac{1 - \sin \phi}{1 + \sin \phi} \text{ at } \alpha = \left(45^\circ - \frac{\phi}{2}\right)$$

where, α is the helix angle and ϕ is the angle of friction.

Solution:

$$\eta_{\max} = \frac{P_o}{P} = \frac{\tan \alpha}{\tan(\alpha + \phi)}$$

For maximum efficiency,

$$\alpha = 45^\circ - \frac{\phi}{2}$$

$$\therefore \eta_{\max} = \frac{\tan\left(45^\circ - \frac{\phi}{2}\right)}{\tan\left(45^\circ - \frac{\phi}{2} + \frac{\phi}{2}\right)} = \frac{\tan\left(45^\circ - \frac{\phi}{2}\right)}{\tan\left(45^\circ + \frac{\phi}{2}\right)}$$

$$= \frac{\frac{\tan 45^\circ - \tan \phi/2}{1 + \tan 45^\circ \tan \phi/2}}{\frac{\tan 45^\circ + \tan \phi/2}{1 - \tan 45^\circ \tan \phi/2}} = \frac{1 - \tan \phi/2}{1 + \tan \phi/2} \cdot \frac{1 + \tan \phi/2}{1 - \tan \phi/2}$$

$$\eta_{\max} = \frac{(1 - \tan \phi/2)^2}{(1 + \tan \phi/2)^2} = \frac{\left[1 - \frac{\sin \phi/2}{\cos \phi/2}\right]^2}{\left(1 + \frac{\sin \phi/2}{\cos \phi/2}\right)^2}$$

$$\begin{aligned} \therefore \eta_{\max} &= \frac{\left(\cos \frac{\phi}{2} - \sin \frac{\phi}{2}\right)^2}{\left(\cos \frac{\phi}{2} + \sin \frac{\phi}{2}\right)^2} \\ &= \frac{\cos^2 \frac{\phi}{2} + \sin^2 \frac{\phi}{2} - 2 \cos \frac{\phi}{2} \sin \frac{\phi}{2}}{\cos^2 \frac{\phi}{2} + \sin^2 \frac{\phi}{2} + 2 \cos \frac{\phi}{2} \sin \frac{\phi}{2}} \\ &= \frac{1 - 2 \cos \frac{\phi}{2} \sin \frac{\phi}{2}}{1 + 2 \cos \frac{\phi}{2} \sin \frac{\phi}{2}} = \frac{1 - \sin \phi}{1 + \sin \phi} \end{aligned}$$

Hence, shown.

Example 2.21: A screw thread of a screw jack has a mean diameter of 10 cm and a pitch of 1.25 cm. The coefficient of friction between the screw and its nut housing is 0.25. Determine the force F that must be applied at the end of a 50 cm lever arm to raise a mass of 5000 kg. Is the device self-locking? Also determine its efficiency. [U.P.T.U. I Sem., 2001–02]

Solution:

Load, $W = 5000 \times 9.81 = 49050 \text{ N}$

Pitch, $p = 12.5 \text{ mm}$

Lever arm, $R = 50 \text{ cm} = 0.5 \text{ m}$

Mean screw radius, $r = \frac{10 \text{ cm}}{2} = 50 \text{ mm}$

$$\mu = 0.25$$

$$\phi = \tan^{-1} \mu = \tan^{-1} 0.25 = 14^\circ$$

$$\tan \alpha = \frac{p}{2\pi r} = \frac{12.5}{2\pi \times 50} = 0.0397887$$

$$\therefore \alpha = 2.2785^\circ$$

