



Centurion
UNIVERSITY

Shaping Lives...
Empowering Communities...

Introduction of Computer



Centurion
UNIVERSITY

*Shaping Lives...
Empowering Communities...*

1.1

- A computer is an electronic device, operating under the control of instructions stored in its own memory that can accept data (input), process the data according to specified rules, produce information (output), and store the information for future use.

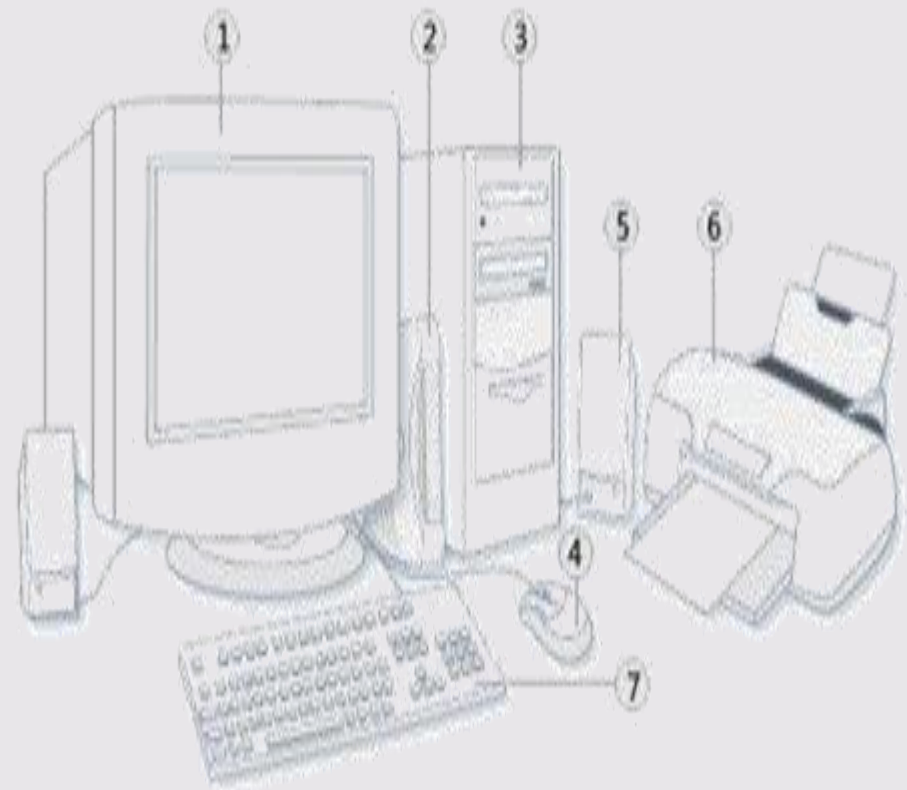

- | | | | |
|-----------|---------------|-----------|------------|
| ① Monitor | ③ System unit | ⑤ Speaker | ⑦ Keyboard |
| ② Modem | ④ Mouse | ⑥ Printer | |



Centurion
UNIVERSITY

*Shaping Lives...
Empowering Communities...*

1.2 Functionalities of a computer

- Any digital computer carries out five functions in gross terms:
- Takes data as input
- Stores data functions in its memory and use them when required.
- Process the data and converts it into useful information
- Generates the output

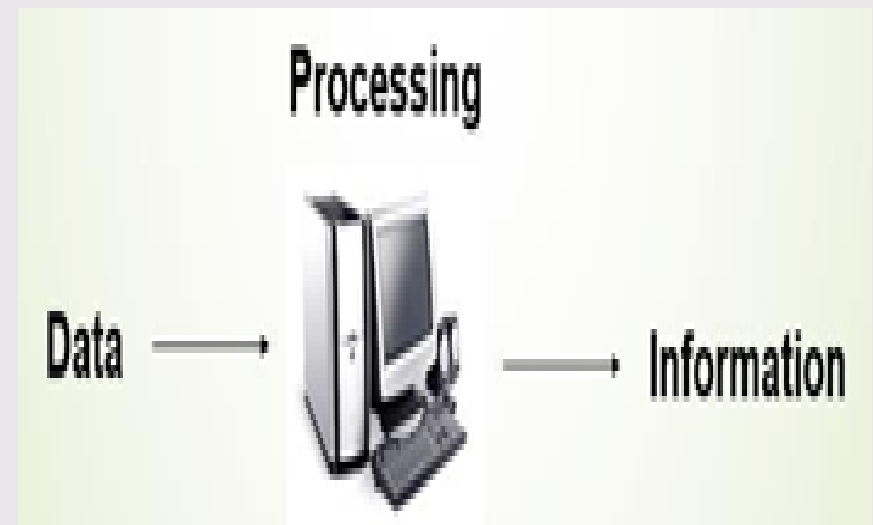



Centurion
UNIVERSITY

*Shaping Lives...
Empowering Communities...*

1.3 Central Processing Unit (CPU)

- A CPU is brain of a computer.
 - It is responsible for all functions and processes.
 - Regarding computing power, the CPU is the most important element of a computer system.
- The CPU is comprised of three main parts :
 - Arithmetic Logic Unit (ALU): Executes all arithmetic and logical operations. Arithmetic calculations like as addition, subtraction, multiplication and division. Logical operation like compare numbers, letters, or special characters



Centurion
UNIVERSITY

Shaping Lives,
Empowering Communities.

- **Control Unit (CU):** controls and co-ordinates computer components.

- Read the code for the next instruction to be executed.
- Increment the program counter so it points to the next instruction.
- Read whatever data the instruction requires from cells in memory.

- - Provide the necessary data to an ALU or register.
- If the instruction requires an ALU or specialized hardware to complete, instruct the hardware to perform the requested operation
- Registers: Stores the data that is to be executed next, "very fast storage area".



Centurion
UNIVERSITY

Shaping Lives...

Empower is Communities...

1.4 Primary Memory

- **RAM:**

Random Access Memory (RAM) is a memory scheme within the computer system responsible for storing data on a temporary basis, so that it can be promptly accessed by the processor as and when needed. It is volatile in nature, which means that data will be erased once supply to the storage device is turned off.

- RAM stores data randomly and the processor accesses these data randomly from the RAM storage. RAM is considered "random access" because you can access any memory cell directly if you know the row and column that intersect at that cell.
- ROM (Read Only Memory): ROM is a permanent form of storage. ROM stays active regardless of whether power supply to it is turned on or off. ROM devices do not allow data stored on them to be modified.



Centurion
UNIVERSITY

Shaping Lives...
Empowering Communities...

1.5 Secondary Memory

- Stores data and programs permanently: its retained after the power is turned off
- Hard drive (HD):
- Optical Disk:



Centurion
UNIVERSITY

*Shaping Lives...
Empowering Communities...*

1.6 Software

- Software is a generic term for organized collections of computer data and instructions, often broken into two major categories: system software that provides the basic non-task-specific functions of the computer, and application software which is used by users to accomplish specific tasks.



Centurion
UNIVERSITY

*Shaping Lives...
Empowering Communities...*

1.7 Unit of Measurements

Size example

- 1 bit - answer to an yes/no question
- 1 byte - a number from 0 to 255.
- 90 bytes: enough to store a typical line of text from a book.
- 4 KB: about one page of text.
- 120 KB: the text of a typical pocket book.
- 3 MB - a three minute song (128k bit rate)
- 650-900 MB - an CD-ROM
- 1 GB -114 minutes of uncompressed CD-quality audio at 1.4 Mb
- 8-16 GB - size of a normal flash drive