

# DISTILLATION

**Shubhashree Das**  
**Assistant Professor**  
**School of Pharmacy and Life Sciences**  
**Centurion University of Technology and Management**  
**shubhashree.das@cutm.ac.in**

1

## 4. MOLECULAR DISTILLATION

- It is defined as a distillation process in which each molecule in the vapour phase travels mean free path and gets condensed individually without intermolecular collisions on application of vacuum.
- Molecular distillation is based on the principle of the simple distillation with some modifications. This is also called **Evaporation distillation or Short path distillation**.
- Principle:
- The substances to be distilled have very low vapour pressures. Examples are viscous liquids, oils, greases, waxy materials and high molecular weight substances.
- These boil at very high temperature. In order to decrease the boiling point of the liquids, **high vacuum must be applied**.
- The vapour pressure above the liquid is much lower than that of the saturated vapour in equilibrium. At very low pressure, the distance between the evaporating surface and the condenser is approximately equal to the mean free path of the vapour molecules.
- Molecules leaving the surface of the liquid are more likely **hit** the condenser surface nearby. **each molecule is condensed individually**. the distillate is subsequently collected.

## Applications:

Molecular distillation is used for the purification and separation of chemicals of low vapour pressure.

1. Purification of chemicals such as tricresyl phosphate, dibutyl phthalate and dimethyl phthalate.
2. More frequently used in the refining of fixed oils.
3. Vitamin A is separated from fish liver oil. Vitamin's is concentrated by this method from fish liver oils and other vegetable oils.
4. Free fatty acids are distilled at 100°C.
5. Steroids can be obtained between 100°C and 200°C,
6. Triglycerides can be obtained from 200°C onwards.
7. Proteins and gums will remain as non-volatile residues. Thus, the above mixture can be separated by molecular distillation.

## Theory:

The *mean free path of a molecule* is defined as the average distance through which a molecule can move without coming into collision with another. The mean path ( $\lambda$ ) can be expressed mathematically as:

$$\lambda = \frac{3}{\rho \eta}$$

where.  $p$  = vapour pressure, kPa

$\rho$  = density, kg/m<sup>3</sup>

$\eta$  = viscosity, Pa's

$\lambda$  = mean path length, m

- For example, mean path (heavy molecules) of butyl phthalate is about 30 mm and of olive oil is 20 mm when measured at a pressure of 0.1 pascal.
- The **mean free path can be increased by decreasing the viscosity** which can be obtained **at high temperature and low pressure**. Thus, **nonvolatile substances may become volatile and distillation is possible**.

## Requirements for design the equipment:

- The evaporating surface must be close to the condensing surface. This **ensures the molecules to come in contact with the condenser as soon as they leave the evaporating surface**. For this reason, this process is also known as *short path distillation*.
- The molecular collisions should be minimized because they change the direction of the path of molecules. In other words, intermolecular distances should be fairly high. It can be **achieved under very high vacuum**, usually of the order of **0.1 to 1.0 pascals**.
- The liquid surface area must be as large as possible as so that the **vapour is evolved from the surface only, but not by boiling**. Thus this process is also called *evaporation distillation*.

Based on the method of formation of liquid film, apparatus may be divided into two types:-

### CENTRIFUGAL MOLECULAR DISTILLATION STILL

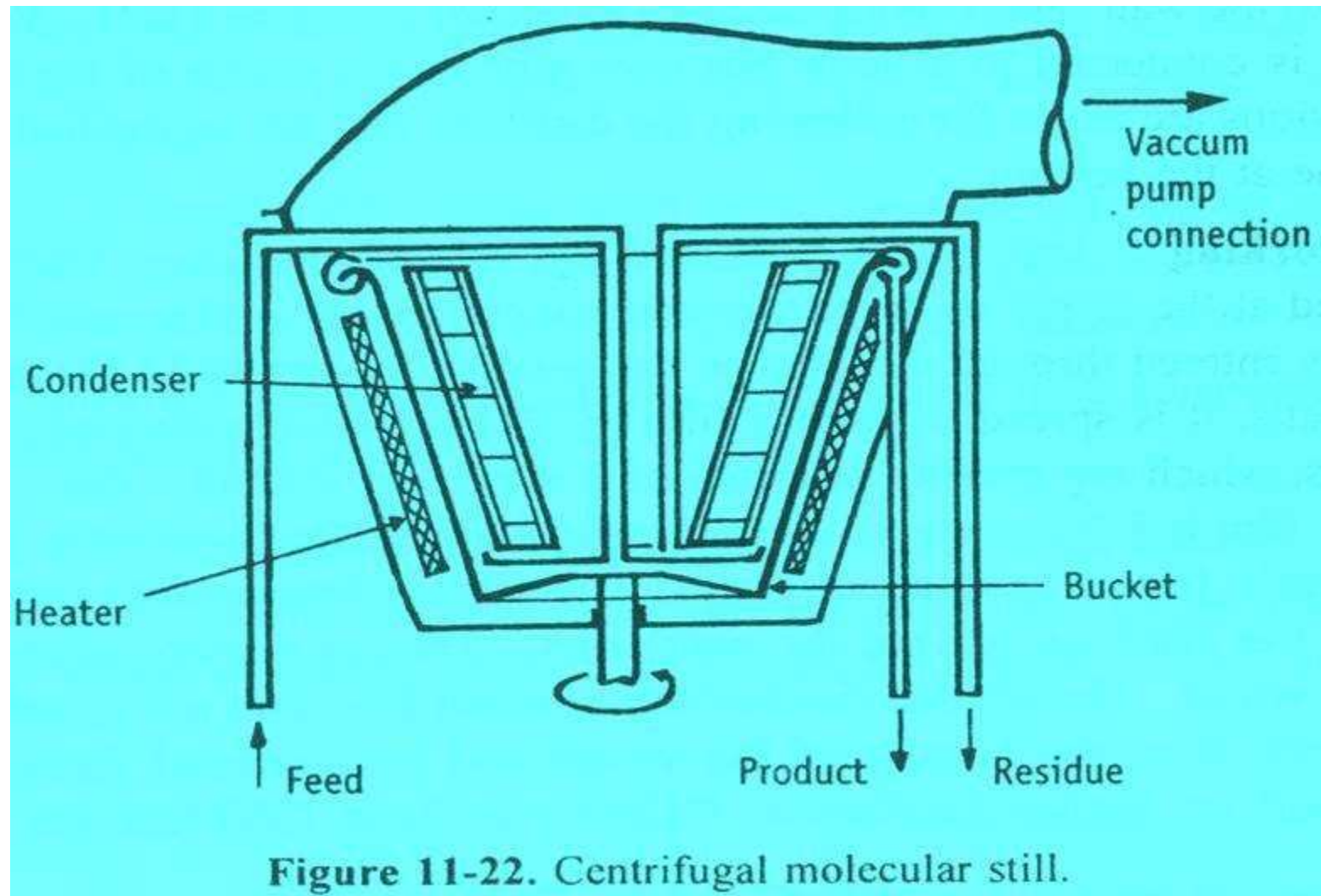

## Principle:

- In this method, liquid feed is introduced into a vessel, which is rotated at very high speed (**centrifugal action**).
- On account of heating, vaporisation occurs from a film of liquid on the sides of the vessel.
- The vapour (molecules) travels a short distance and gets condensed on the adjacent condenser.
- Each molecule is condensed individually. The distillate is subsequently collected.

## Construction:

- ❖ It consists of a bucket-shaped **vessel having a diameter of about 1 to 1.5 m**.
- ❖ It is rotated at high speed using a motor.
- ❖ **Radiant heaters are provided externally** to heat the fluid in the bucket.
- ❖ Condensers are arranged very close to the evaporating surface.
- ❖ Vacuum pump is connected to the entire vessel at the top.
- ❖ Provisions are made *for* introducing the feed into the centre of the bucket, for receiving the product and **residue for re-circulation**.



## Working:

- ❖ **Vacuum is applied** at the centre of the vessel.
- ❖ The bucket shaped vessel is allowed to **rotate at high speed**.
- ❖ The feed is introduced *from* the centre of the vessel.
- ❖ Due to **centrifugal action of the rotating bucket**, liquid moves outward over the surface of the vessel and forms a film.
- ❖ Since, the radiant heaters heat the surface, the liquid evaporates **directly from the film**.
- ❖ The vapour (molecules) **travels its mean free path and strikes the condenser**.
- ❖ The condensate is collected into another vessel.
- ❖ **The residue** is collected from the bottom of the vessel and is **recirculated** through the feed port for further distillation.

## Disadvantages

Construction and operation are more complicated compared to falling film molecular still.

## 4. MOLECULAR DISTILLATION

### WIPED FILM MOLECULAR DISTILLATION STILL/ FALLING FILM MOLECULAR STILL

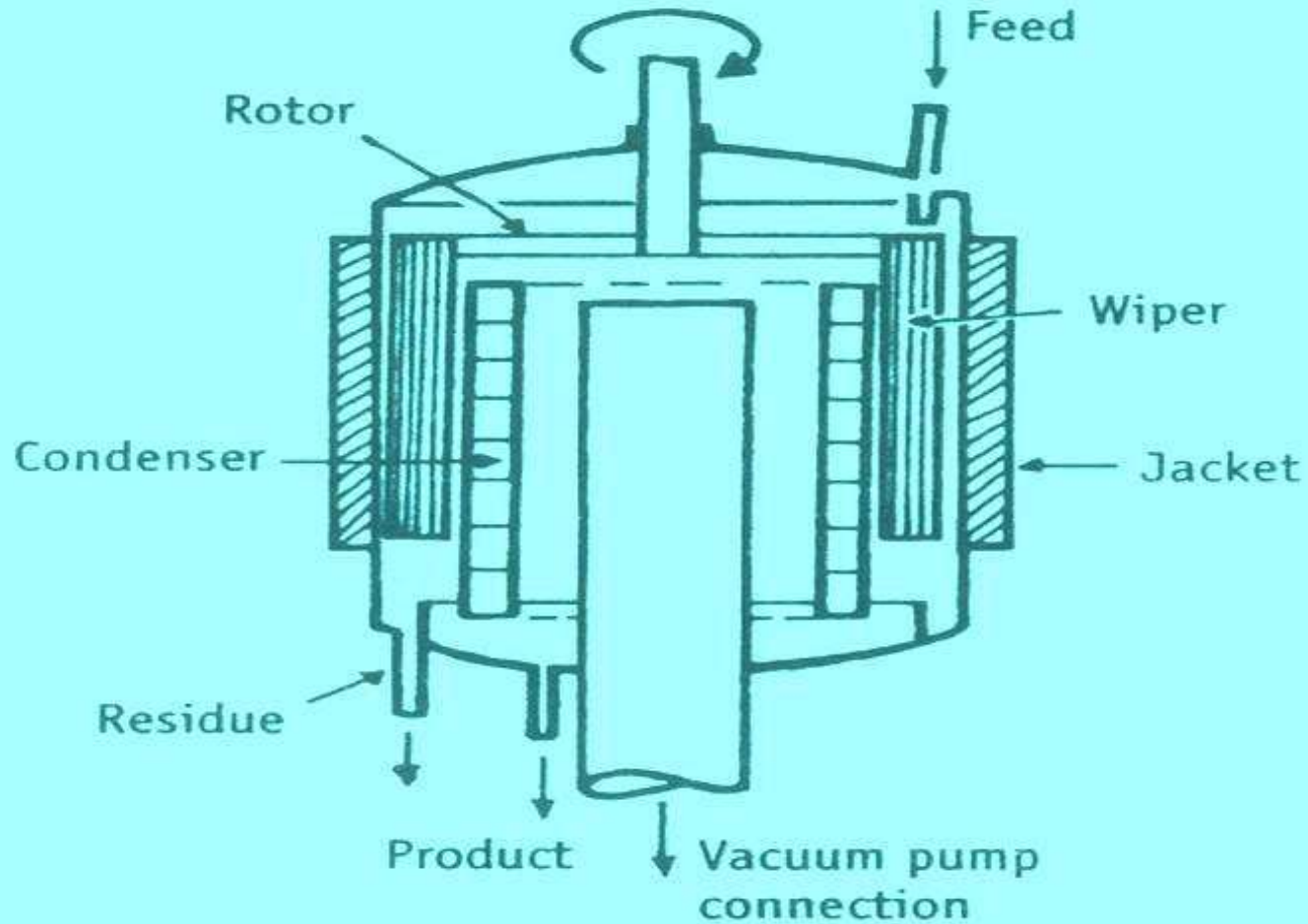

**Figure 11-21.** Wiped film molecular still.



## Principle

- In this method, vapourisation occurs from a film of liquid flowing down a heated surface under high vacuum.
- The vapour (molecule) travels a short distance and strikes the condenser nearby.
- Each molecule is condensed individually. The distillate is subsequently collected.

## Construction:

- ❖ The vessel has a **diameter of 1 m**.
- ❖ The walls of the vessel are provided with suitable means of heating (jacket).
- ❖ **Wipers are provided adjacent to the vessel wall.** Wipers are connected to a rotating head through a rotor.
- ❖ The condensers are arranged very close to the wall (evaporating surface).
- ❖ **Vacuum pump is connected to a large diameter pipe at the centre of the vessel.**
- ❖ Provisions are made for collecting the distillate and the undistilled liquid residue at the bottom.

## Working:

- ❖ The vessel is heated by suitable means.
- ❖ Vacuum is applied at the centre of the vessel and wipers are allowed to rotate.
- ❖ The feed is entered through the inlet of the vessel.
- ❖ As the liquid flows down the walls, it is **spread to form a film by PTFE (polytetrafluoroethylene) wipers**, which are moving at a **rate of 3 m per second**.
- ❖ **The velocity of the film is 1.5 m per second.**
- ❖ Since the **surface is already heated**, the liquid film evaporates directly.
- ❖ The vapour (molecules) travels its **mean free path and strikes the condenser**.
- ❖ The condensate is collected into a vessel.
- ❖ **The residue (undistilled or mean free path not travelled) is collected from the bottom of the vessel and re-circulated through the feed port for further distillation. *Capacity is about 1000 L / hour.***

# 5. STEAM DISTILLATION

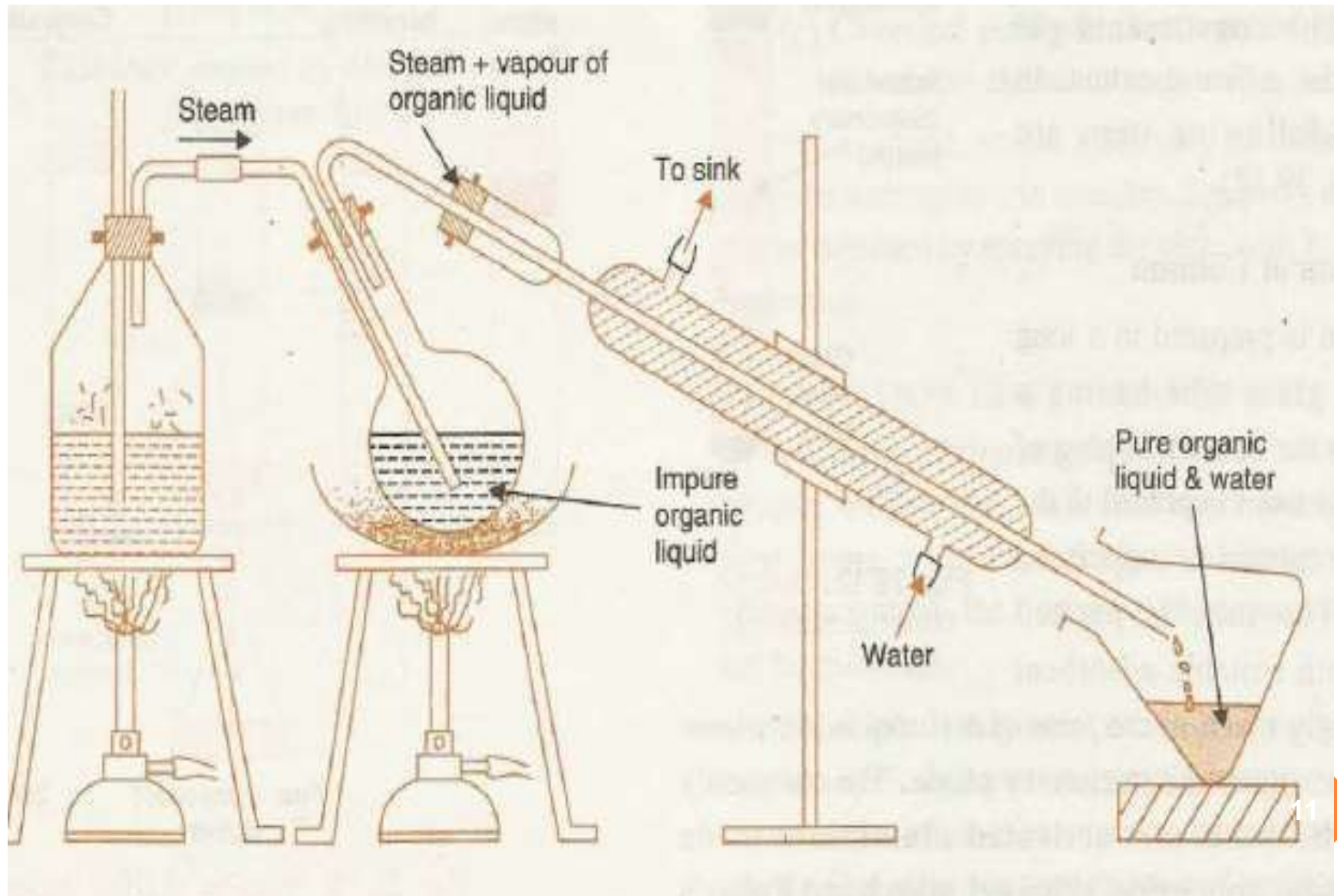

## 5. STEAM DISTILLATION

- Steam distillation is method of distillation carried out with aid of steam.
- It is used to separate
  - High boiling substances from non-volatile impurities
  - immiscible liquids (insoluble in water)

### Example:

Boiling point of Turpentine = 160 °C

Boiling point of Water + Turpentine Mixture = 95.6 °C

At this temperature Vapour pressure of

Water = 86.245 kPa (647 mmHg)

Turpentine = 15.06 kPa (113 mmHg)

Sum of vapour pressure = 101.31 kPa (760 mmHg)

Which is normal atmospheric pressure and thus high boiling liquid may be distilled with water at a temperature much below its boiling point.

## Principle:

A mixture of immiscible liquids begins to boil when sum of their vapour pressure is equal to atmospheric pressure.

In case of mixture of water and turpentine, mixture boils below the boiling point of pure water, though the turpentine boils at a much higher temperature than that of water.

## Application:

- Used to separate immiscible liquids. Ex- Water + Toluene
- To extract volatile oils like clove, anise and eucalyptus oils.
- Purification of liquid with high boiling point, for example essential oils of almond.
- Camphor is distilled by this method.
- Aromatic water are prepared by this method.

## Advantages:

Volatile oils can be separated at a lower temperature in steam distillation, without any decomposition and loss of aroma. If a substance has low volatility, it can be satisfactorily distilled, provided its molecular weight is considerably higher than water.

## Disadvantages:

Not suitable when immiscible liquid and water react with each other.

## **Construction of assembly:**

- Metallic steam can fitted with cork having two holes.
- Safety tube inserted up to bottom through one hole to maintain pressure in side stem can, more over when steam comes out from safety tube indicates that can is empty.
- Through other hole band tube is passed and other end of this tube is connected to flask containing non-aqueous liquid in which tube is dipped.
- Flask and condenser is connected with delivery tube.
- Condenser is connected to receiver with help of adopter.
- Provision are made to heat both steam can and flask separately.

## **Working:**

- The non-aqueous liquid is placed in the flask.
- A small quantity of water is added to it. Steam can is fitted with water.
- The steam generator and the flask are heated simultaneously, so that a uniform flow of steam passes through the boiling mixture. The mixture gets heated.
- The steam carries the volatile oil and passes into the condenser, which is cooled by cold water. The condensed immiscible liquid is collected into the receiver.
- Distillation is continued until all the non-aqueous liquid has been distilled. In the receiver, water and organic liquid form two separate layers, which can be easily separated using a separating flask.
- For volatile substance, which are miscible with water, distillation with steam would involve the same principle of fractional distillation.