

Superposition Theorem

Superposition theorem is one of those strokes of genius that takes a complex subject and simplifies it in a way that makes perfect sense. The strategy used in the Superposition Theorem is to eliminate all but one source of power within a network at a time, using series/parallel analysis to determine voltage drops (and/or currents) within the modified network for each power source separately. Then, once voltage drops and/or currents have been determined for each power source working separately, the values are all "superimposed" on top of each other (added algebraically) to find the actual voltage drops/currents with all sources active.

Consider a circuit shown below and apply Superposition Theorem to it:

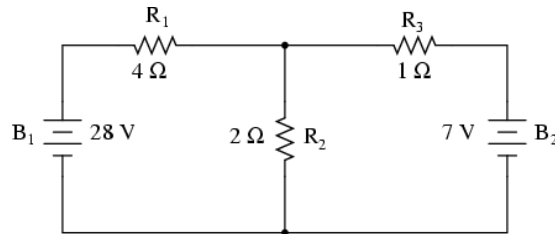

Since we have two sources of power in this circuit, we will have to calculate two sets of values for voltage drops and/or currents, one for the circuit with only the 28 volt battery in effect and one for the circuit with only the 7 volt battery in effect:

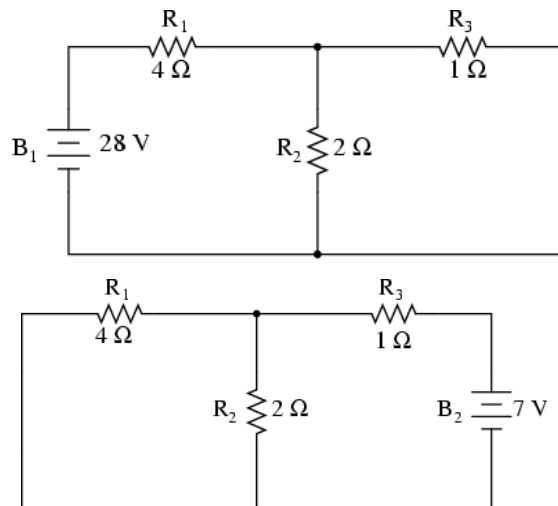

When re-drawing the circuit for series/parallel analysis with one source, all other voltage sources are replaced by wires (shorts), and all current sources with open circuits (breaks). Since we only have

voltage sources (batteries) in our example circuit, we will replace every inactive source during analysis with a wire.

Analyzing the circuit with only the 28 volt battery, we obtain the following values for voltage and current:

	R_1	R_2	R_3	$R_2 // R_3$	$R_1 + R_2 // R_3$ Total	
E	24	4	4	4	28	Volts
I	6	2	4	6	6	Amps
R	4	2	1	0.667	4.667	Ohms

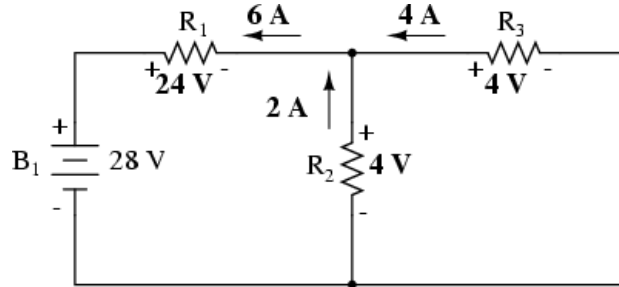

Analyzing the circuit with only the 7 volt battery, we obtain another set of values for voltage and current:

	R_1	R_2	R_3	$R_1 // R_2$	$R_3 + R_1 // R_2$ Total	
E	4	4	3	4	7	Volts
I	1	2	3	3	3	Amps
R	4	2	1	1.333	2.333	Ohms

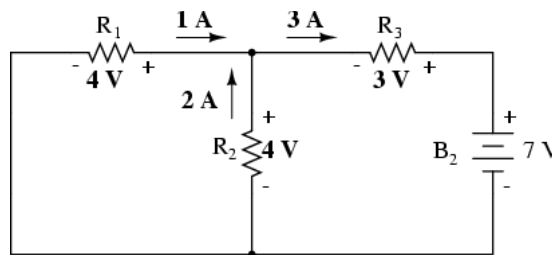





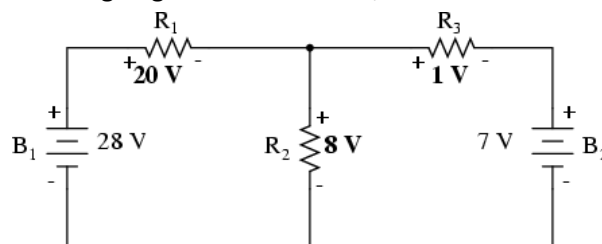

When superimposing these values of voltage and current, we have to be very careful to consider polarity (voltage drop) and direction (electron flow), as the values have to be added *algebraically*.

With 28 V battery	With 7 V battery	With both batteries
E_{R1}	E_{R1}	E_{R1} $24\text{ V} - 4\text{ V} = 20\text{ V}$
E_{R2}	E_{R2}	E_{R2} $4\text{ V} + 4\text{ V} = 8\text{ V}$
E_{R3}	E_{R3}	E_{R3} $4\text{ V} - 3\text{ V} = 1\text{ V}$

Applying these superimposed voltage figures to the circuit, the end result looks something like this:

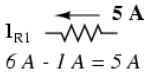
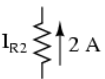

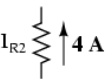
Currents add up algebraically as well, and can either be superimposed as done with the resistor voltage drops, or simply calculated from the final voltage drops and respective resistances ($I=E/R$). Either way, the answers will be the same. Here I will show the superposition method

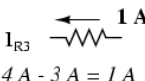
With 28 V battery	With 7 V battery	With both batteries
 I_{R1}	 I_{R1}	 I_{R1} $6 A - 1 A = 5 A$
 I_{R2}	 I_{R2}	 I_{R2} $2 A + 2 A = 4 A$
 I_{R3}	 I_{R3}	 I_{R3} $4 A - 3 A = 1 A$

applied to current:

Once again applying these superimposed figures to our circuit:

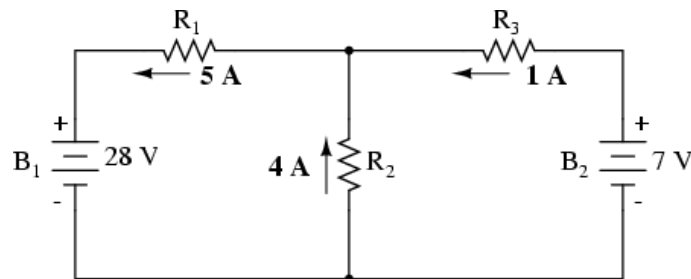

Quite simple and elegant, don't you think? It must be noted, though, that the Superposition Theorem works only for circuits that are reducible to series/parallel combinations for each of the power sources at a time (thus, this theorem is useless for analyzing an unbalanced bridge circuit), and it only works where the underlying equations are linear (no mathematical powers or roots). The requisite of linearity means that Superposition Theorem is only applicable for determining voltage and current, *not power!!!* Power dissipations, being nonlinear functions, do not algebraically add to an accurate total when only one source is considered at a time. The need for linearity also means this Theorem cannot be applied in circuits where the resistance of a component changes with voltage or current. Hence, networks containing components like lamps (incandescent or gas-discharge) or varistors could not be analyzed.

Another prerequisite for Superposition Theorem is that all components must be "bilateral," meaning that they behave the same with electrons flowing either direction through them. Resistors have no polarity-specific behavior, and so the circuits we've been studying so far all meet this criterion.

The Superposition Theorem finds use in the study of alternating current (AC) circuits, and semiconductor (amplifier) circuits, where sometimes AC is often mixed (superimposed) with DC. Because AC voltage and current equations (Ohm's Law) are linear just like DC, we can use Superposition to analyze the circuit with just the DC power source, then just the AC power source, combining the results to tell what will happen with both AC and DC sources in effect. For now, though, Superposition will suffice as a break from having to do simultaneous equations to analyze a circuit.

REVIEW:

- The Superposition Theorem states that a circuit can be analyzed with only one source of power at a time, the corresponding component voltages and currents algebraically added to find out what they'll do with all power sources in effect.
- To negate all but one power source for analysis, replace any source of voltage (batteries) with a wire; replace any current source with an open (break).