

Welding

Welding is a process which two materials, usually metals, are permanently joined together through localized coalescence, resulting from a suitable combination of ***temperature, pressure*** and metallurgical conditions.

Various welding processes have been classified in five groups, namely:

Oxyfuel gas welding,

Arc welding,

Resistance welding,

Solid state welding and

Unique processes.

Welding

I. Oxyfuel Gas Welding (OFW)

Covers a group of welding processes that utilize as the heat source a flame resulting from burning of a fuel gas and oxygen, mixed in proper proportions.

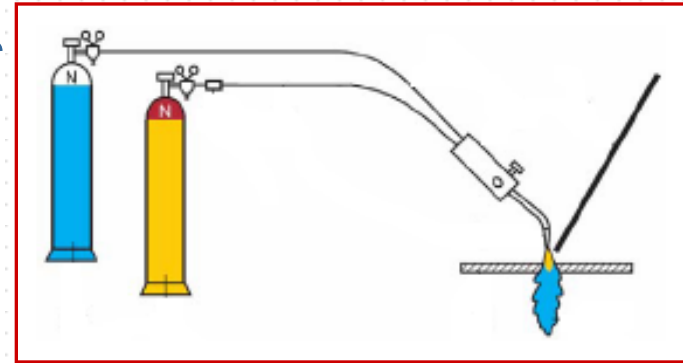

- *A welding torch is used to mix and burn the gases.*
- **Acetylene** is the principal fuel gas employed for this process.
- *Acetylene gas is obtained by a reaction between Calcium Carbide and water.*
- *The combustion of oxygen and acetylene produces a temperature of about **3500°C**.*

Oxyfuel Gas Welding (OFW)

Oxyfuel gas welding is a **fusion** welding process, the metals being joined are **melted** at the point where welding occurs.

No pressure is applied.

Because a slight gap exists between the pieces being joined, filler material usually must be added in the form of a **wire** or **rod** (which is called **electrode**) that is melted in the flame or in the pool of weld metal.

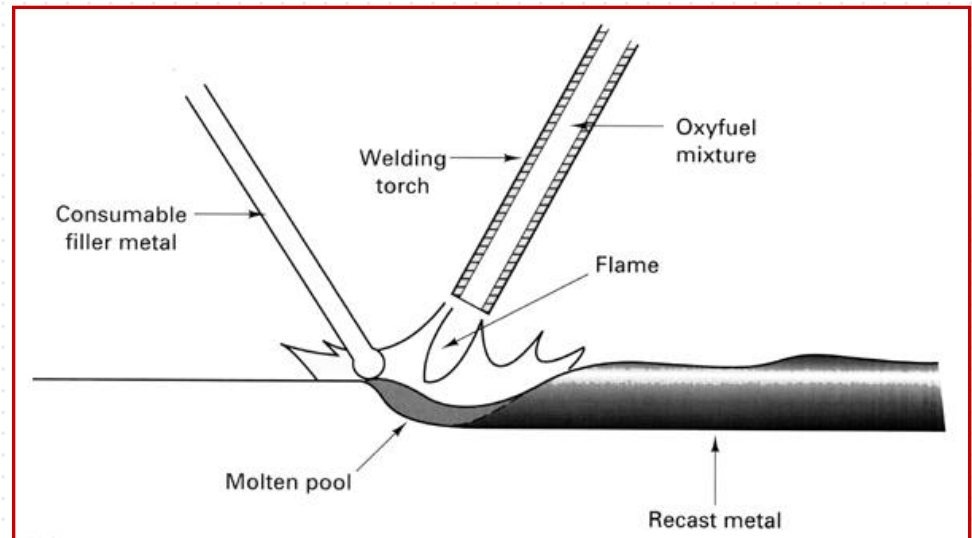

Oxyfuel Gas Welding (OFW)

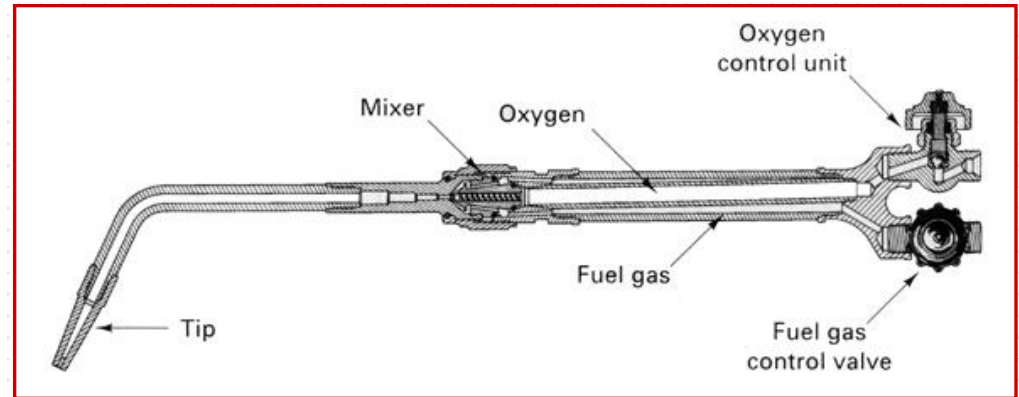
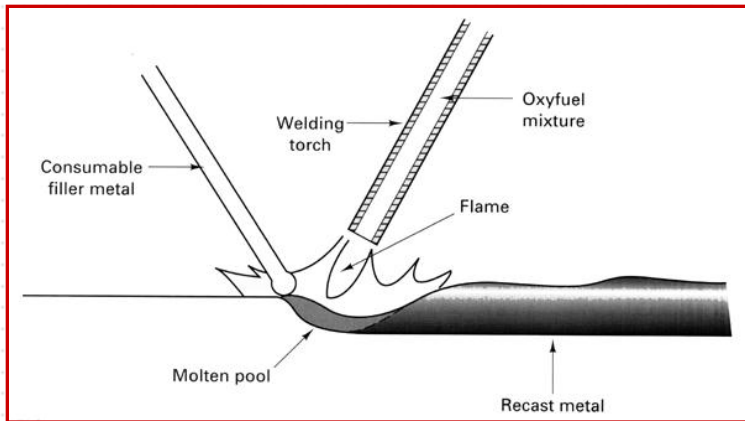

Composition of the electrode material should be similar (compatible) to the workpiece materials which are going to be welded (parent materials).

Fluxes can be added as a powder, or the welding rod can be dipped in a flux paste. Fluxes play a very important part by dissolving oxides that may be on the surface prior to heating, and by preventing the formation of oxides during heating.

Welding

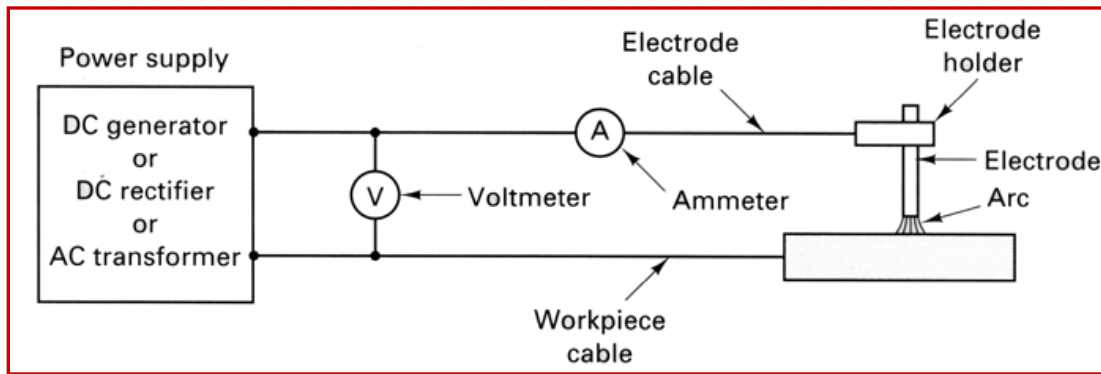

II. Arc Welding (W)

- Heat is obtained by an **arc** between the work and electrode.
- Arc welding is a **fusion** welding process, the metals being joined are melted at the point where welding occurs.
- Useful, versatile, and widely used process.
- But, for most applications, weld quality depends on the skill and integrity of the operator.

Arc Welding

All arc welding is done with metal **electrodes**.

In some applications, the electrode is consumed, i.e. melted and thus supplies the needed filler metal.

In some other applications of arc welding, the electrode is made of **tungsten**, which is not consumed by the arc except by relative slow vaporization.

Here a **separate** filler wire must be added to supply the needed metal, i.e. to be consumed.

Composition of the **consumed material** should be **similar** (compatible) to the parent materials.

Arc Welding

1. Shielded Metal Arc Welding (SMAW)

Uses electrodes, which are mostly finite-length sticks, that consist of metal wire, upon which is extruded a **coating** containing chemical components that add a number of desirable characteristics

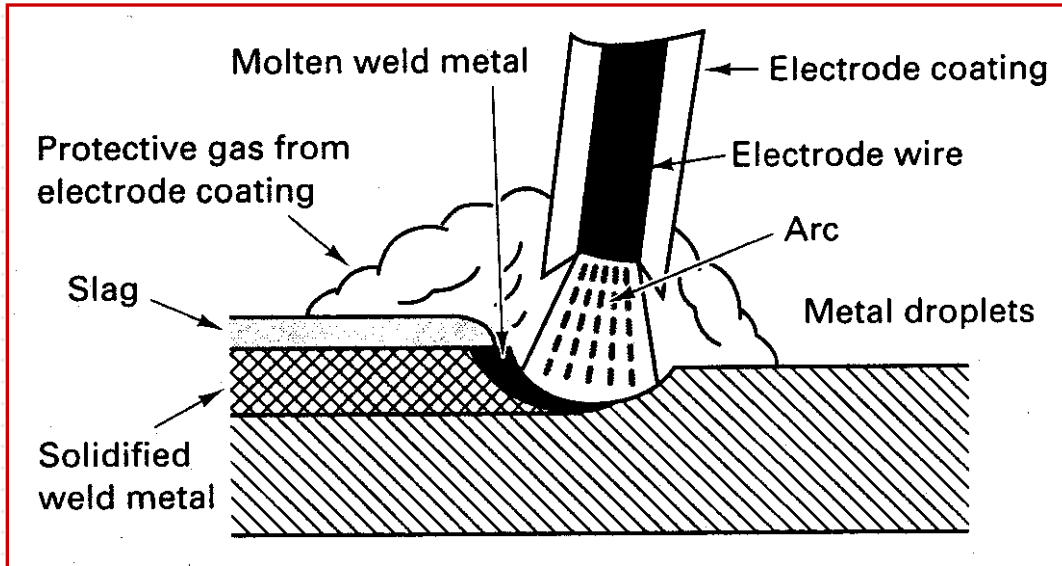

Shielded Metal Arc Welding (SMAW)

Coating containing chemical components add a number of desirable characteristics, including all or a number of the following.

- *Add additional filler metal.*
- *Act as a **flux** to remove impurities from the molten metal.*
- *Provide a **protective atmosphere**.*
- *Provide a protective **slag** to accumulate impurities, prevent oxidation, and slow down the cooling of the weld metal.
(**The slug should be removed afterwards.**)*
- *Stabilize the arc.*
- *Reduce weld-metal spatter and increase the efficiency of deposition.*
- *Add alloying elements.*
- *Affect arc penetration.*
- *Influence the shape of the weld bead.*

Arc Welding

2. Gas Tungsten Arc Welding (GTAW)

- The process formerly was known as **Tungsten Inert Gas (TIG) Welding**.
- Heat is obtained from an arc between the **tungsten electrode** and the workpiece.
- Tungsten electrode is **nonconsumable**.
- Filler metal is supplied separately in form of **wire electrode**.

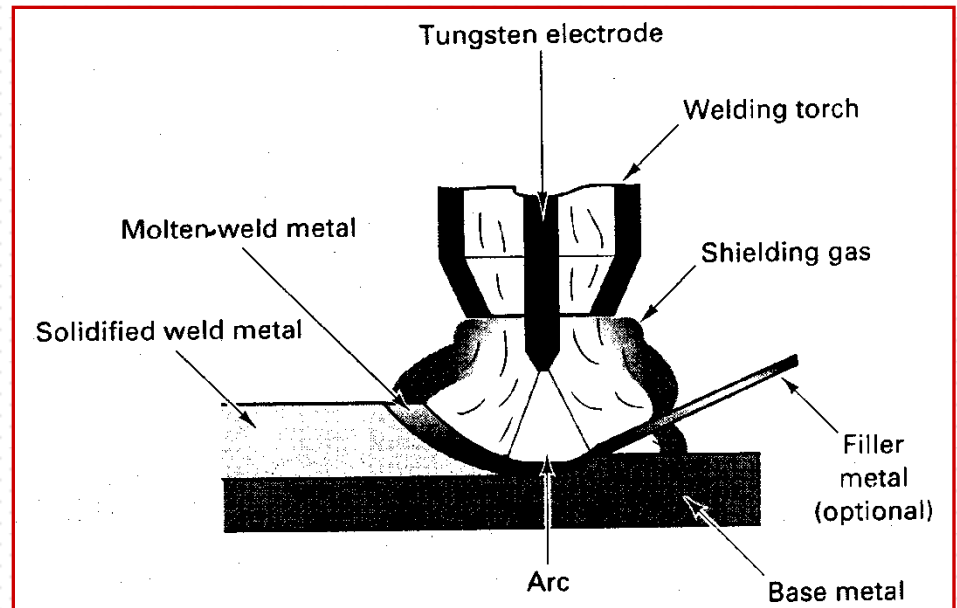
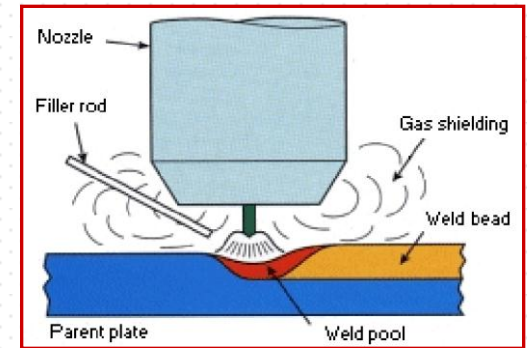

Gas Tungsten Arc Welding (GTAW)

The tungsten electrode is held in a **special holder** through which an **inert gas** is supplied with sufficient flow to form an **inert shield** around the arc and the molten pool of metal, thereby shielding them from the atmosphere.

Argon or helium, or a **mixture** of them, is used as the inert shielding medium.

Produces **very clean welds**, and no special cleaning or slag removal is required because no flux is employed.

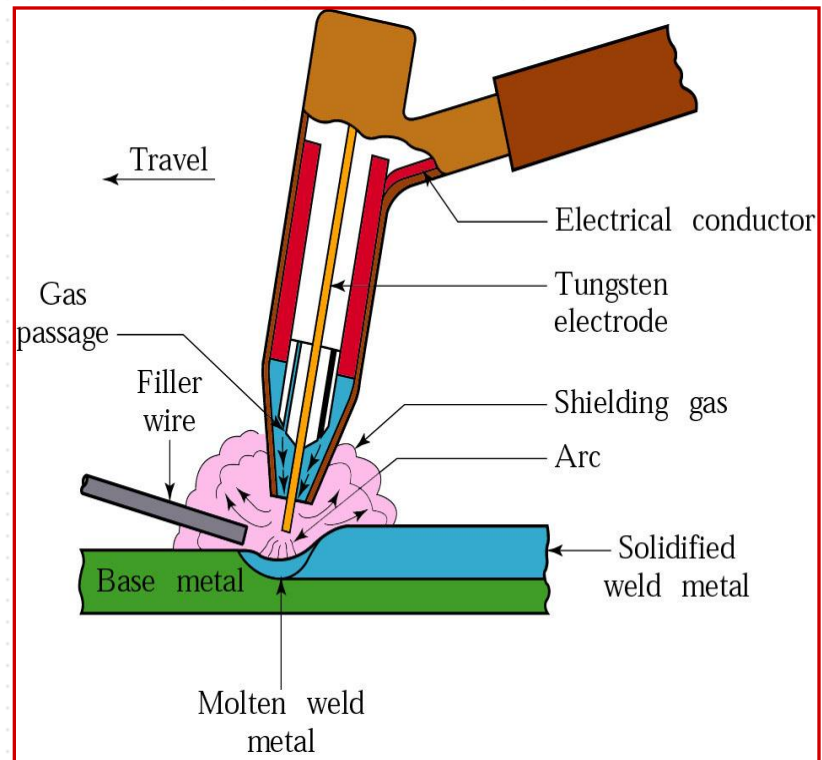

Arc Welding

4. Gas Metal Arc Welding (GMAW)

- The process formerly was known as **Metal Inert Gas (MIG) Welding**.
- Heat is obtained from an arc between the metal electrode and the workpiece.
- Metal electrode, which is in wire form, is **consumable**, i.e. supplies the filler metal.

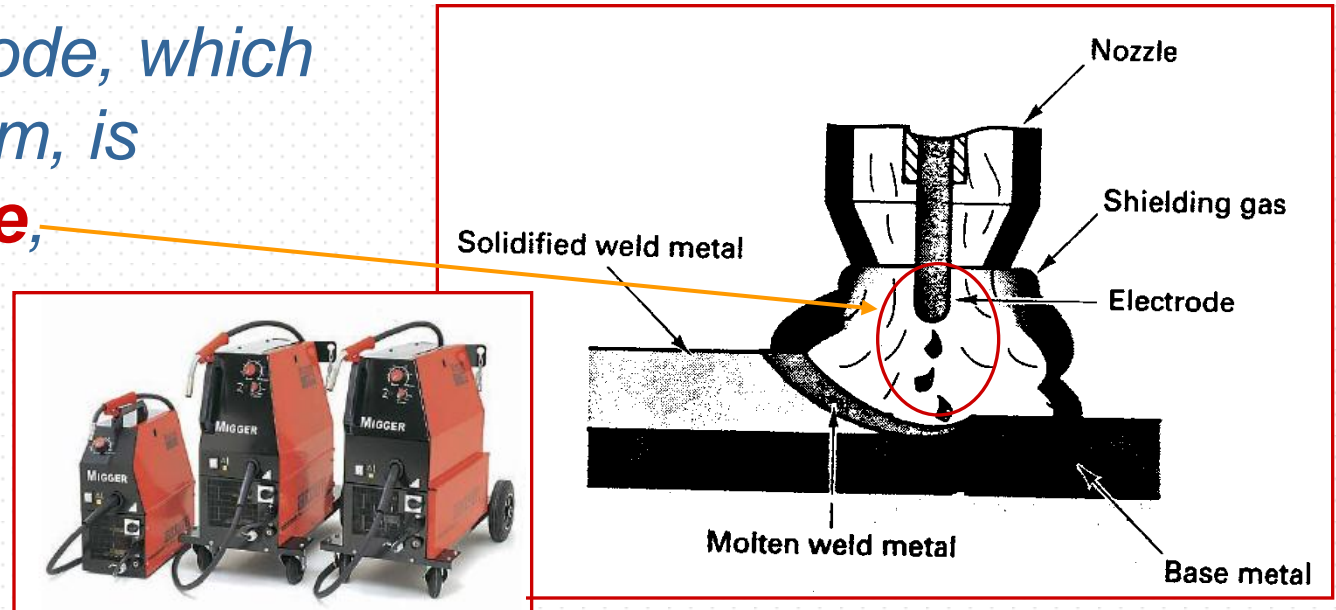
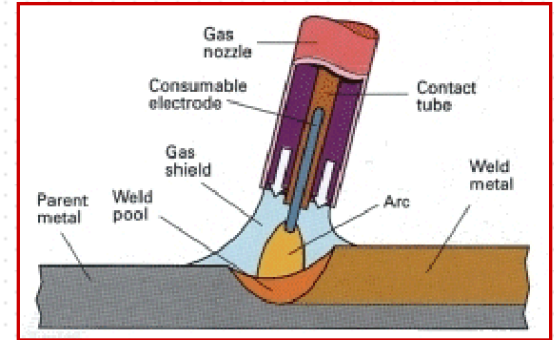

Gas Metal Arc Welding (GMAW)

- *Fast and economical, since there is no frequent changing of electrodes, as with stick-type electrodes.*
- *There is no slag formed over the weld.*
- *The process can be automated, can be performed by industrial robots.*
- *An **inert gas** is supplied with sufficient flow to form an **inert shield** around the arc and the molten pool of metal, thereby shielding them from the atmosphere.*
- *Although, **argon** or **helium**, or a **mixture** of them, can be used for welding virtually any metal, they are used primarily for welding **nonferrous** metals.*

Arc Welding

5. Submerged Arc Welding (SAW)

- The arc is maintained *beneath* a blanket of *granular fusible flux*.
- The flux is deposited just ahead of the electrode, which is in the form of coiled wire.
- The granular flux provides *excellent shielding* of the molten metal and, because the pool of molten metal is relatively large, good fluxing action occurs, so as to remove impurities.
- Consequently *very high quality welds* are obtained.

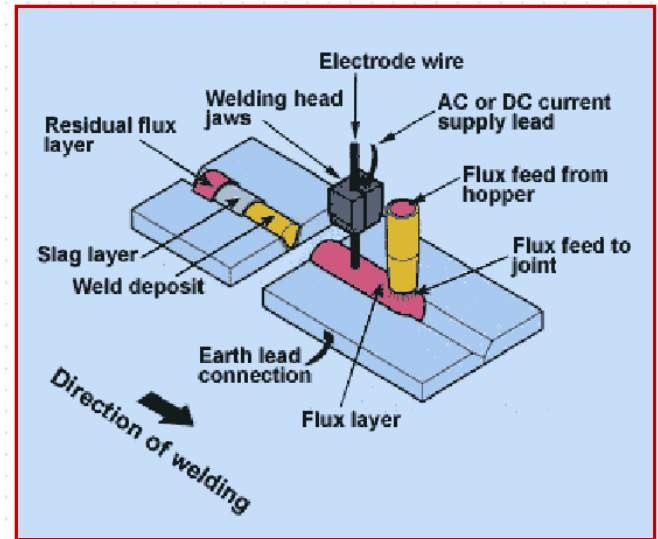

Submerged Arc Welding (SAW)

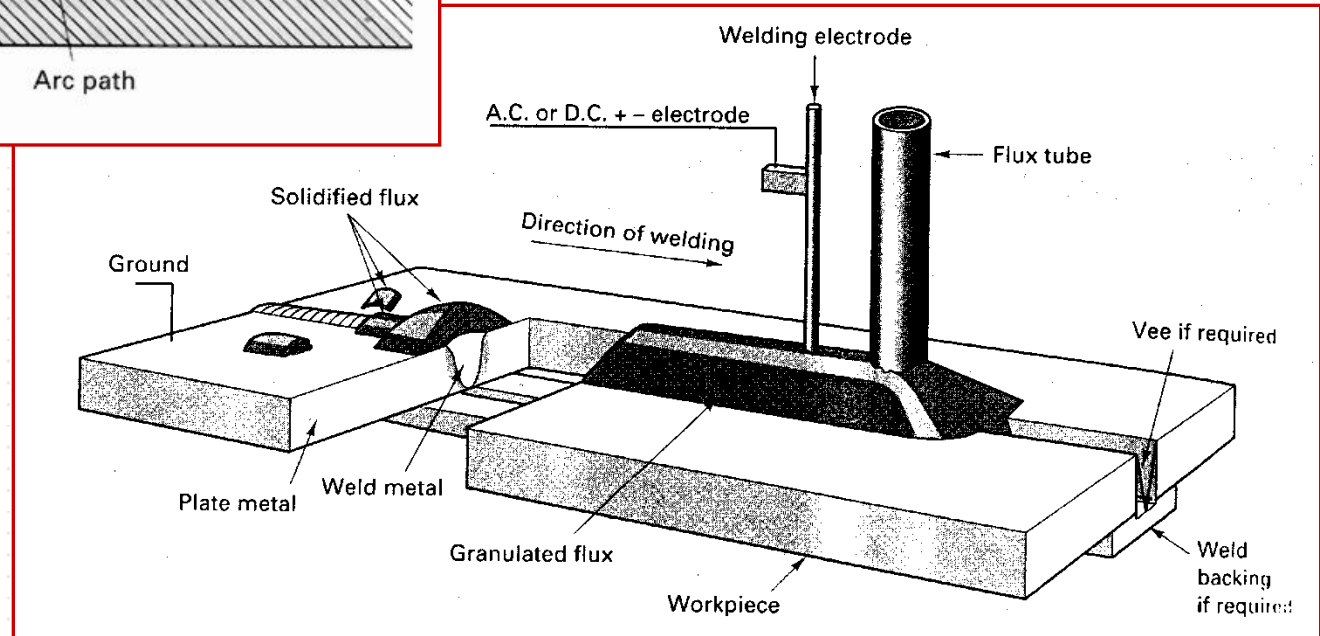
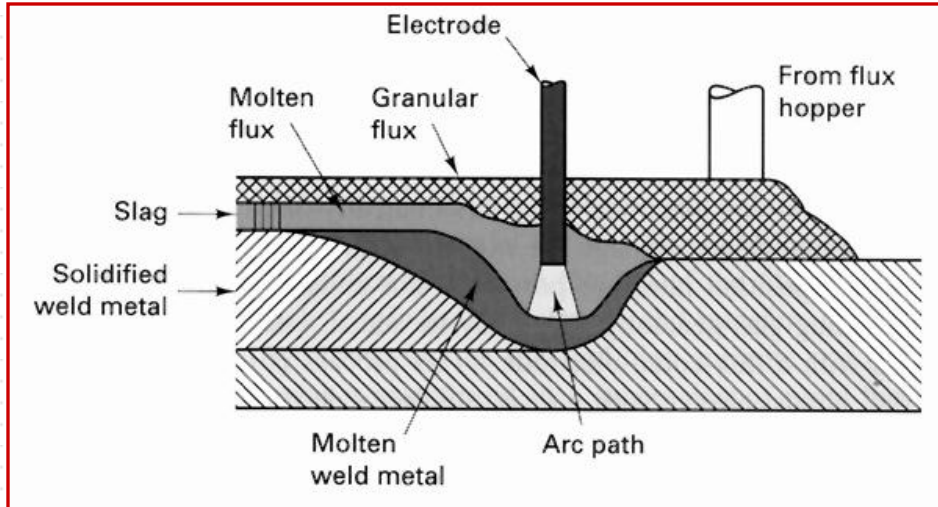

Submerged Arc Welding (SAW)

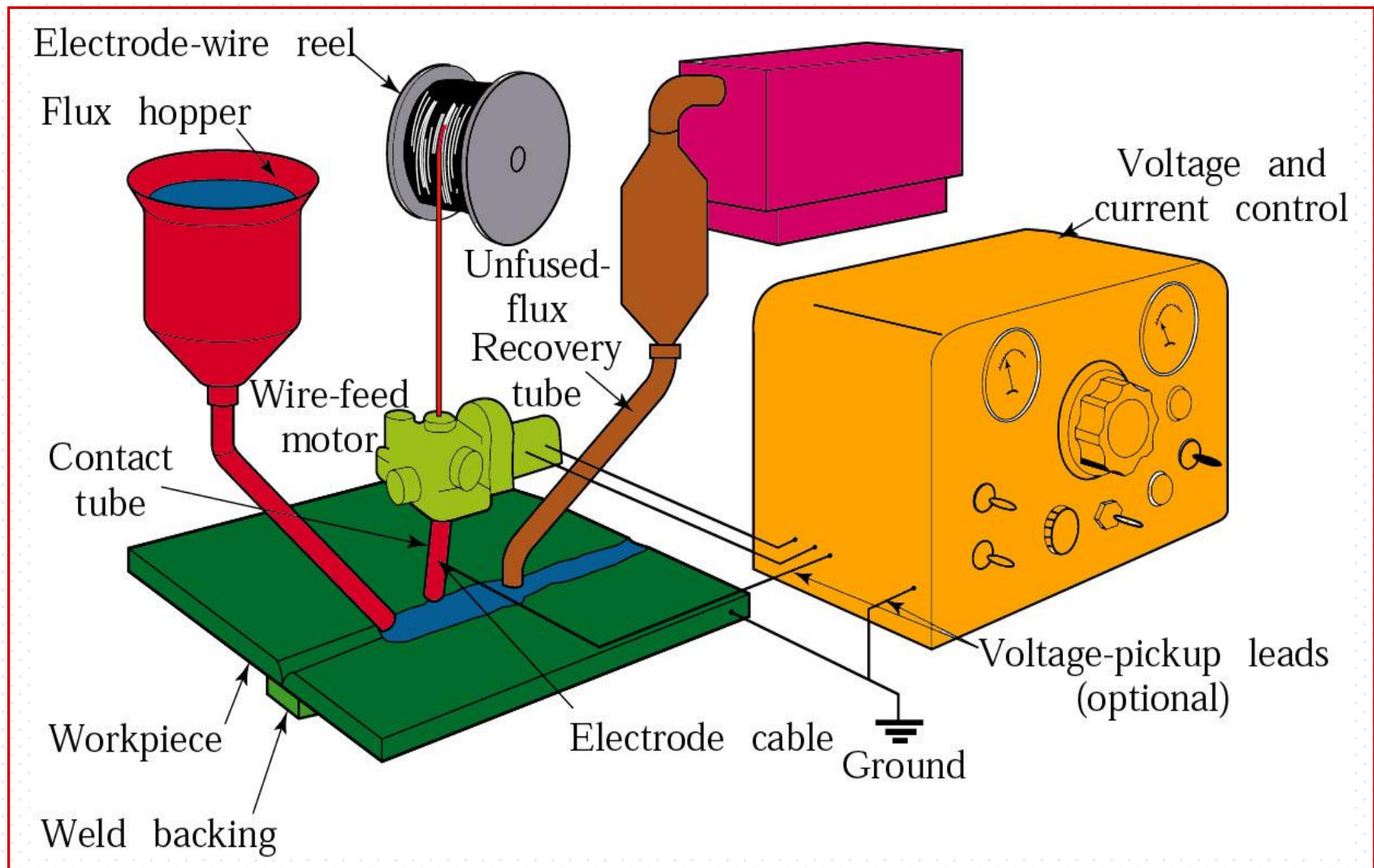

Submerged Arc Welding (SAW)

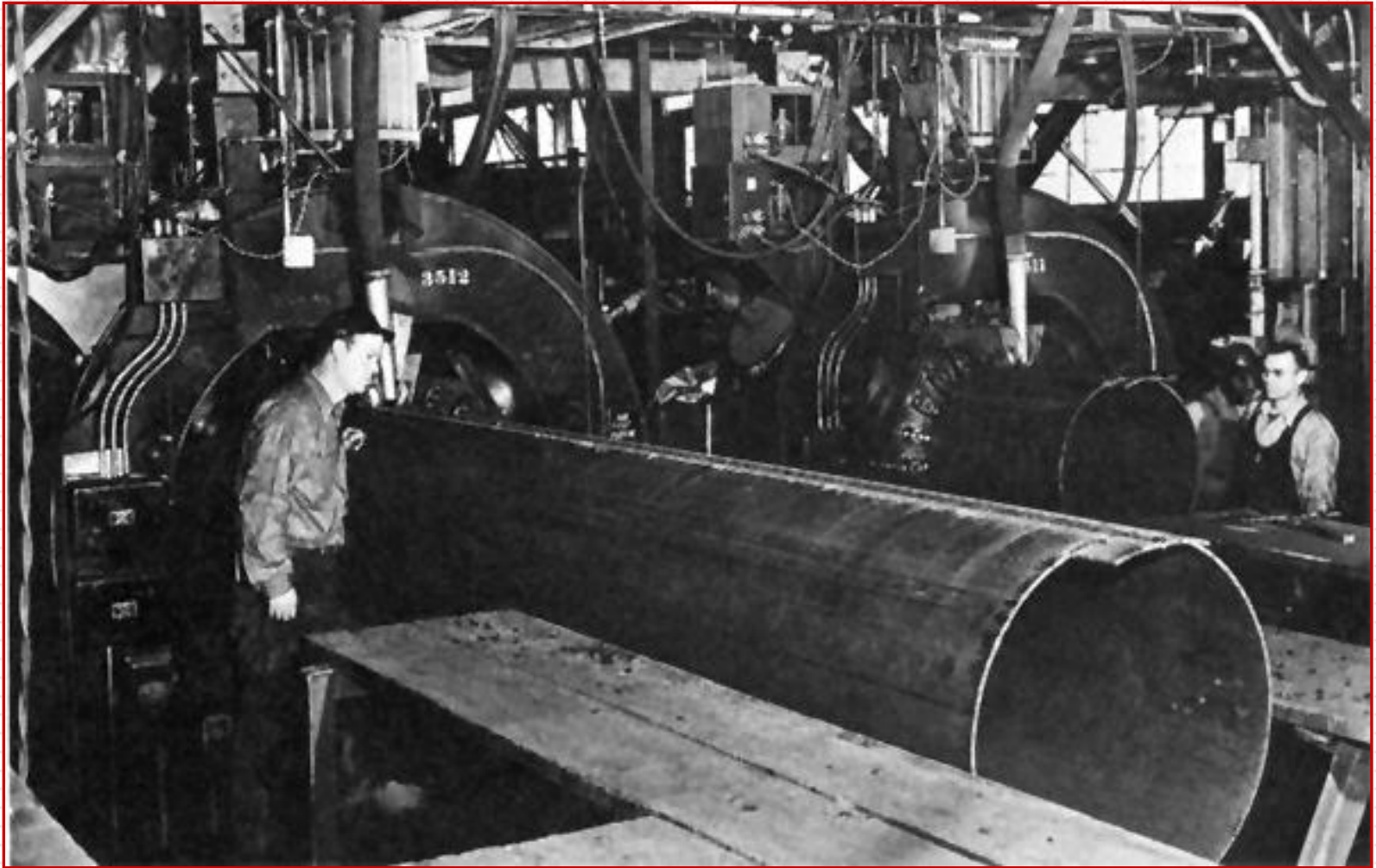

III. Resistance Welding (RW)

- *Both heat and pressure are utilized in producing coalescence.*
- *The heat is the consequence of the resistances of the workpieces and the interface between them to the flow of electrical current.*
- *Very rapid and economical process, widely used in mass production.*
 - 1. Resistance Spot Welding (RSW)***
 - 2. Resistance Seam Welding (RSEW)***

Resistance Welding

1. Resistance Spot Welding (RSW)

- Two or more sheets of metal are held between metal, water cooled electrodes of spot-welding machines, or portable spot welding guns.

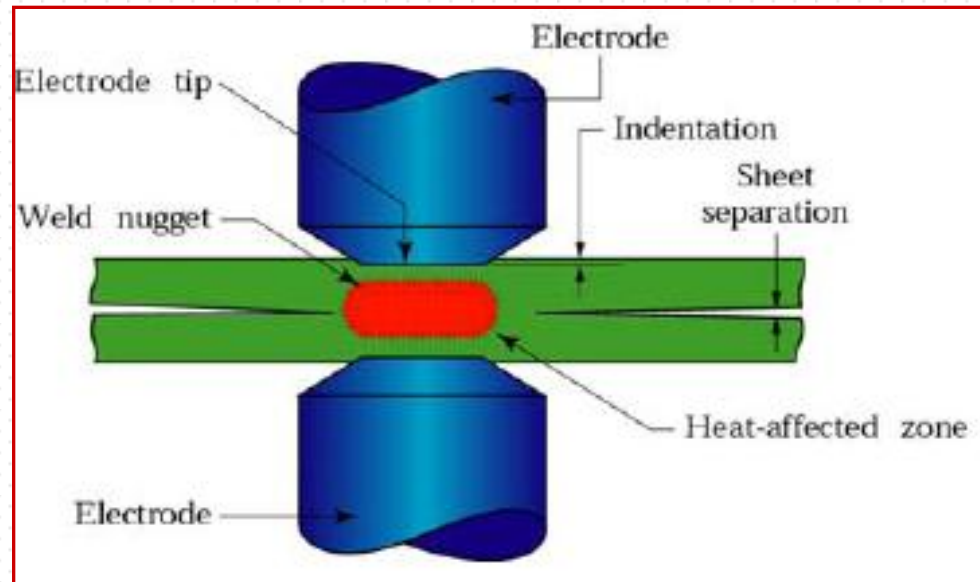

Resistance Spot Welding (RSW)

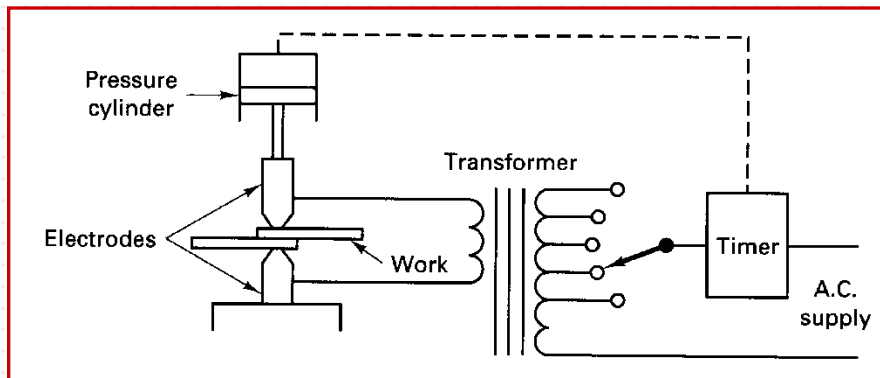
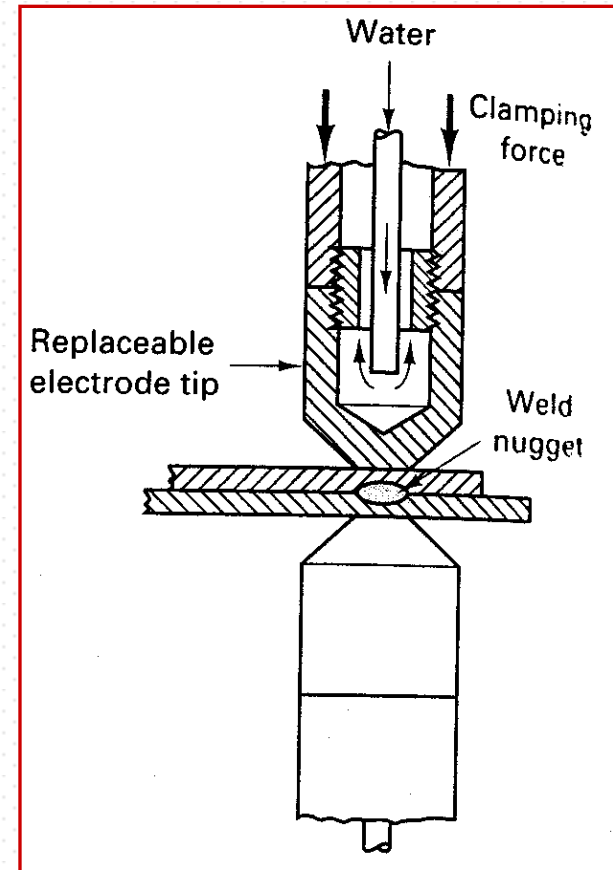
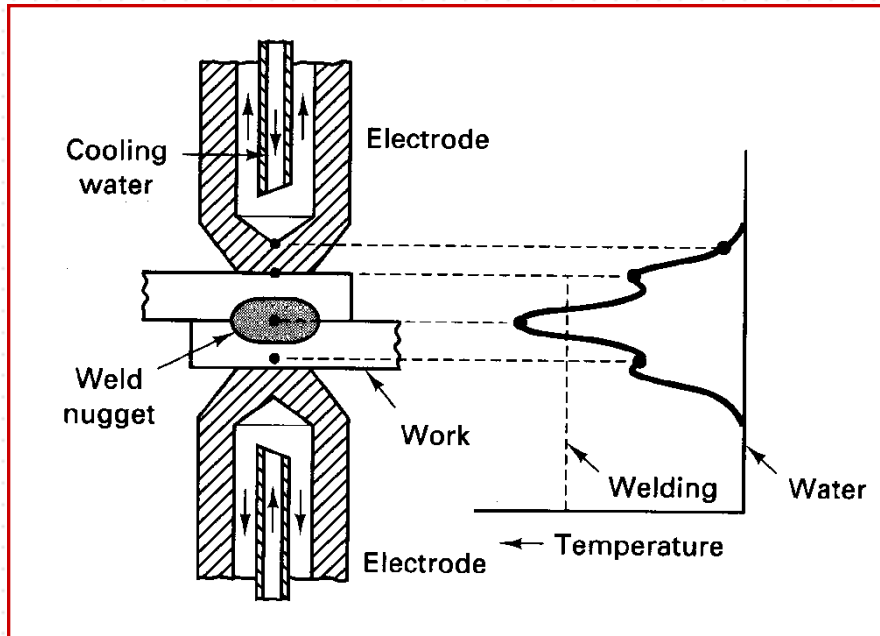

Resistance Spot Welding (RSW)

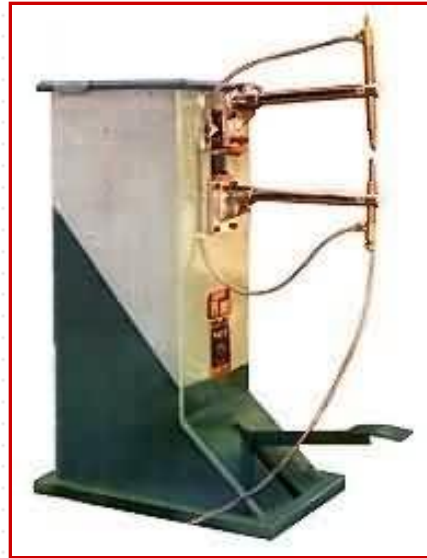
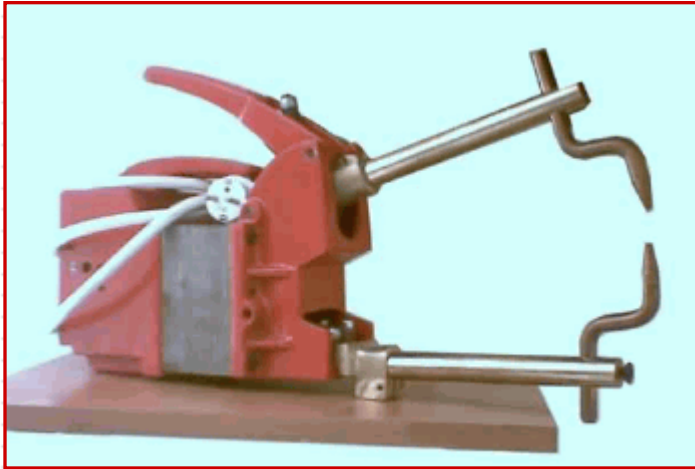

Resistance Welding

2. Resistance Seam Welding (RSEW)

In most cases, where the weld is between two sheets of metal, the seam is actually a series of **overlapping spot welds**.

The basic equipment is the same as for spot welds, except that two rotating disks are used as electrodes.

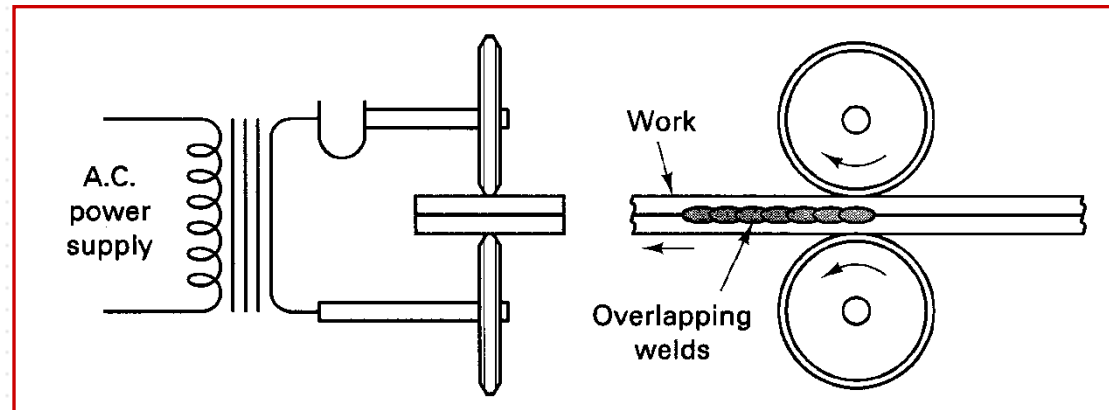
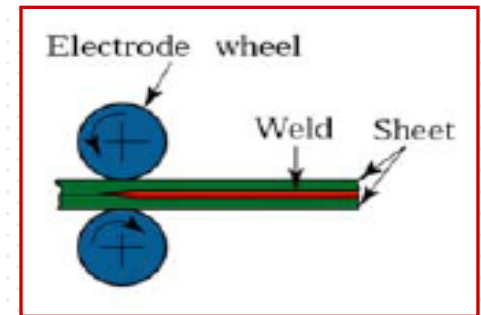
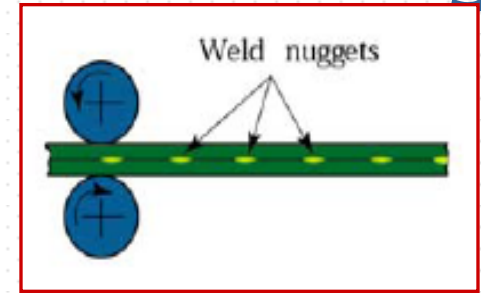

Resistance Seam Welding (RSEW) - a

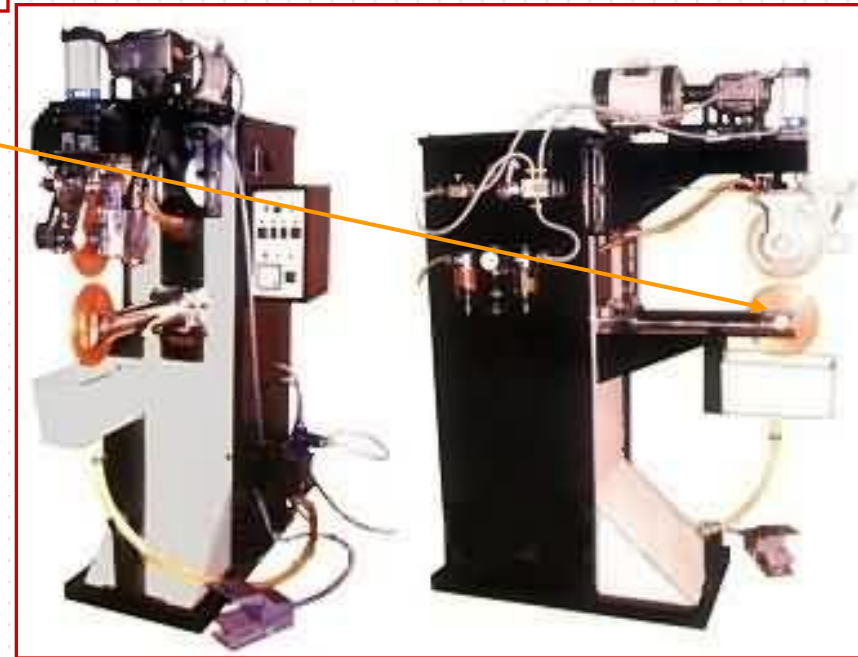
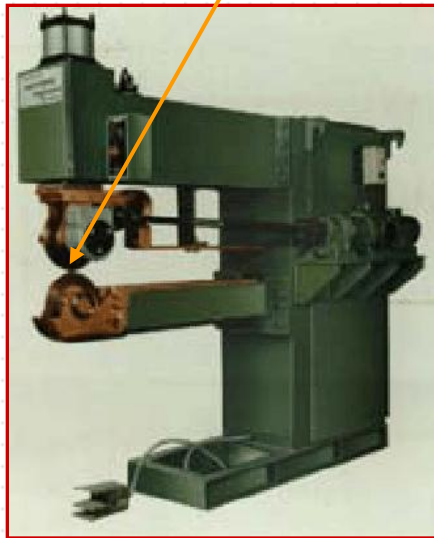
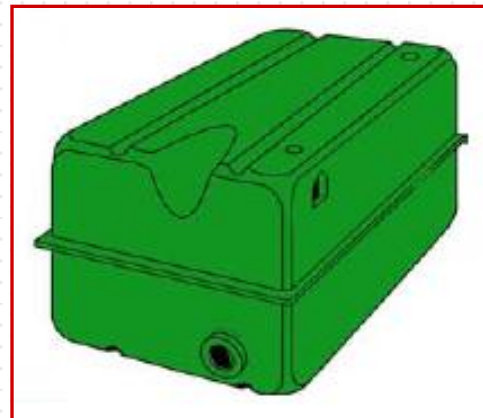
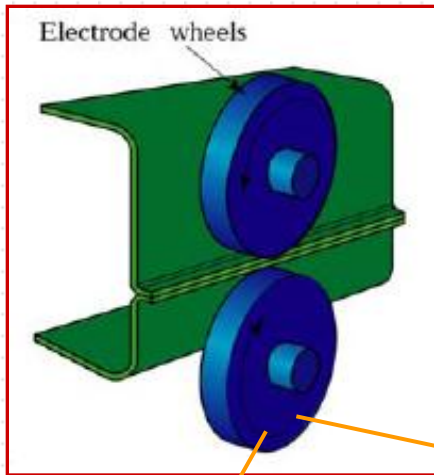

IV. Solid State Welding (SSW)

1. Friction Welding (FRW) (Inertia Welding)

The heat is the result of *mechanical friction* between two contacting pieces of metal that are held together while one *rotates* and the other is held stationary.

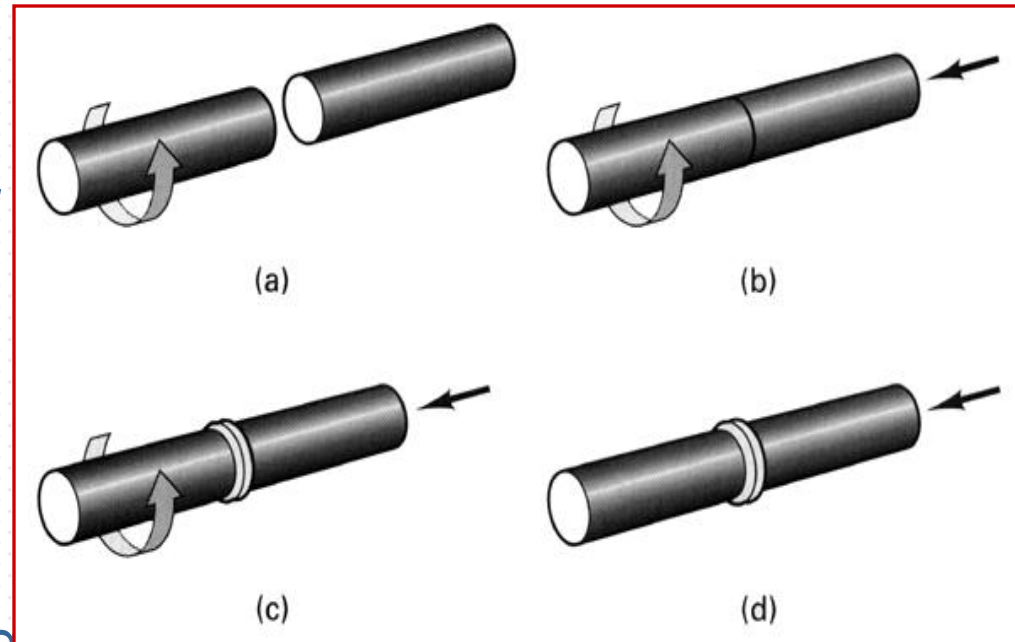

- No material is melted.
- Simple and rapid process (cycle time for a weld is usually less than 25 seconds).

Friction Welding (FRW)

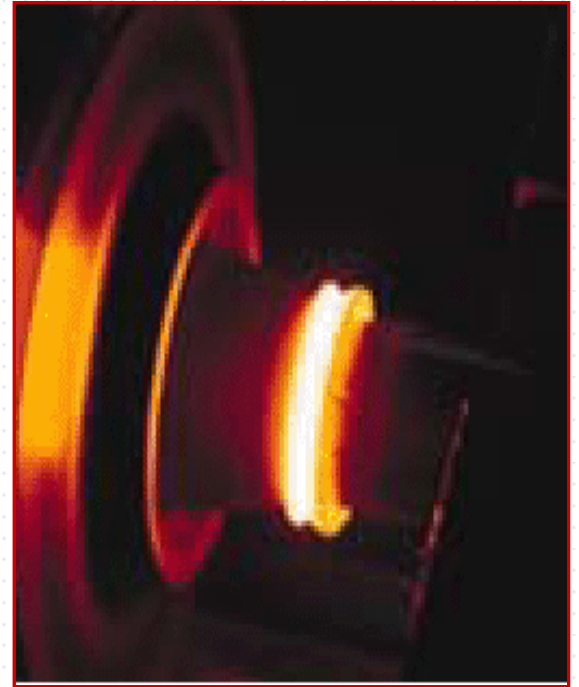

Friction Welding (FRW)

- *Since all of the energy used is converted into **heat**, the process is very efficient.*
- *The strength of the weld is almost the same as the base metal.*
- ***Dissimilar materials** can be welded.*
- *Surface impurities are displaced radially into a small flash that can be removed after welding, if desired.*
- *Restricted to joining round bars and tubes of the **same size**, or to joining bars and tubes to flat surfaces.*
- *Before the process, the ends of the workpieces must be cut true and fairly smooth.*

Friction Welding (FRW)

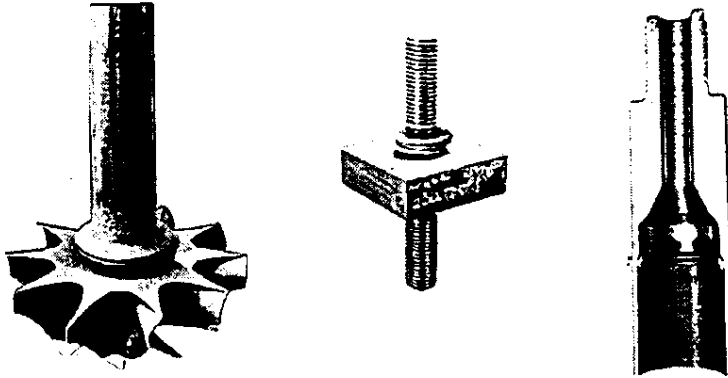
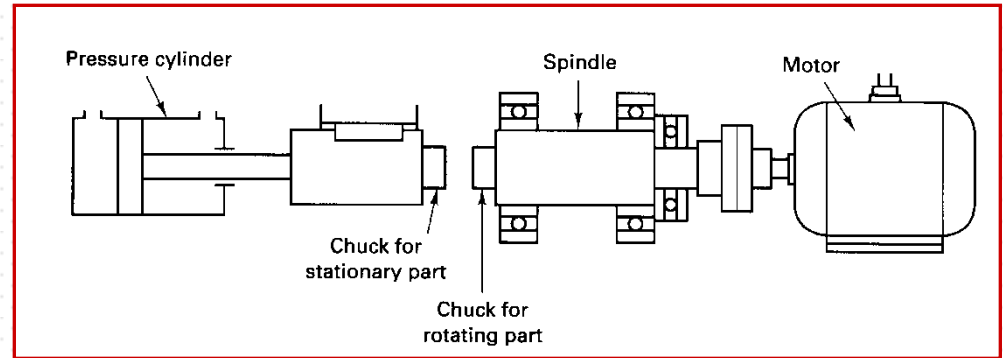
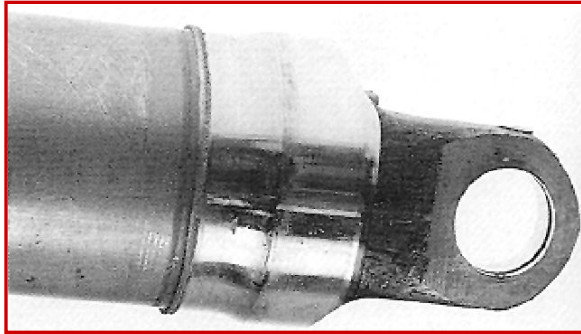
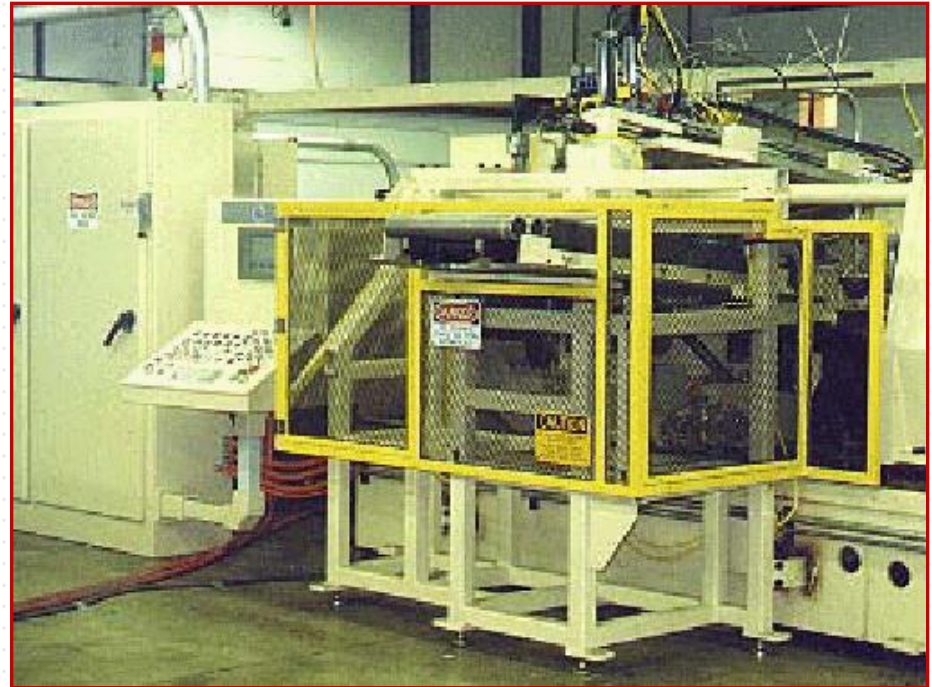

FIGURE 36-6 Some typical friction-welded parts. (Left) Impeller made by joining a chrome-moly steel shaft to a nickel-steel casting. (Center) Stud plate with two mild steel studs joined to a square plate. (Right) Tube component where a turned segment is joined to medium-carbon steel tubing. (Courtesy of Newcor Bay City, Div. of Newcor, Inc.)



Brazing and Soldering

Brazing and soldering are somewhat similar processes with some common properties as given below.

- *The compositions of the brazing and soldering alloys, which are **nonferrous alloys**, are **significantly different** from the **base metals** (materials that are going to be joined).*
- *The **melting point** of these alloys are **lower** than that of the **base metal**.*
- *Therefore, during the process the **base metals are not melted**.*
- *Heating a brazed or soldered joint above the melting point of the used alloy may destroy the integrity of the joint.*

Brazing and Soldering

For both processes, the surfaces should be cleaned beforehand.

- ***Fluxes** play a very important part by dissolving oxides that may be on the surface prior to heating, and by preventing the formation of oxides during heating.*
- ***Borax** has been a commonly used brazing fluid.*
- *Although fluxes will dissolve modest amounts of oxides, they are not cleaners.*
- *Before a flux is applied, dirt, particularly oil, should be removed from the surfaces that are to be joined.*
- *After the process flux residues must be completely removed, since most of them are **corrosive**.*

Brazing and Soldering

1. Brazing

*Melting temperature of braze material is above 450°C
(The 450°C, which is an arbitrary value, is set to distinguish brazing from soldering).*

Braze materials are:

- *copper
(for brazing of steel, HSS, and tungsten carbide),*
- *copper alloys
(e.g. brazing brass, manganese bronze),*
- *silver (for brazing titanium),*
- *silver alloys,*
- *aluminum-silicon alloys.*

Brazing

Capillary attraction plays an important role in *distributing* the braze metal in the joint.

For capillary attraction to exist, the *clearance* between the parts being joined must be *quite small*.

A brazed joint derives its *strength* from a combination of the *braze metal* and the *base-metal alloy* that is formed and the *penetration* of the *low-viscosity brazing metal* into the *grain boundaries* of the *base metal*.

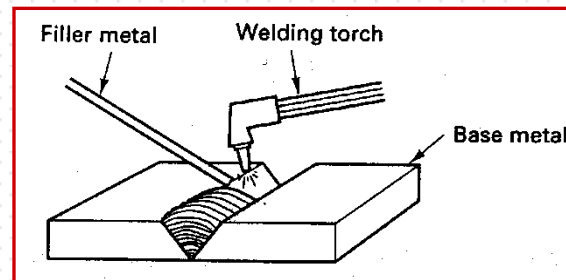

Advantages of Brazing

- 1. Virtually all metals can be joined.*
- 2. Less heating is required than for welding; the process can be performed more quickly and more economically.*
- 3. Since lower temperatures are used, fewer difficulties due to distortion are encountered, and thinner and more complex assemblies can be joined successfully.*
- 4. Many brazing operations are adaptable to automation.*

Heating Methods used for Brazing

1. *Torch brazing* →
2. *Furnace brazing*
3. *Salt bath brazing*
4. *Dip brazing*
5. *Induction brazing*
6. *Resistance brazing*

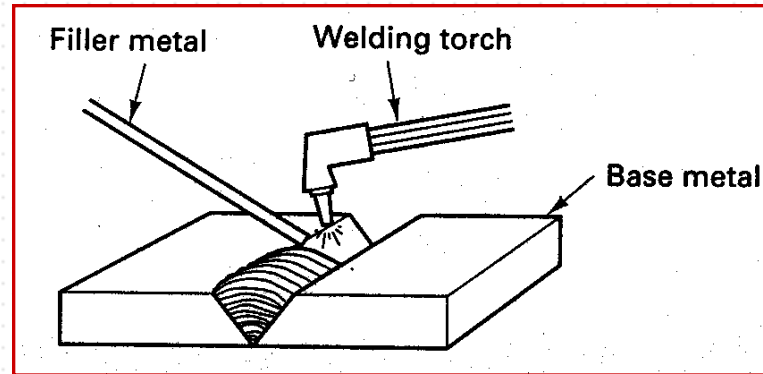

Furnace Brazing

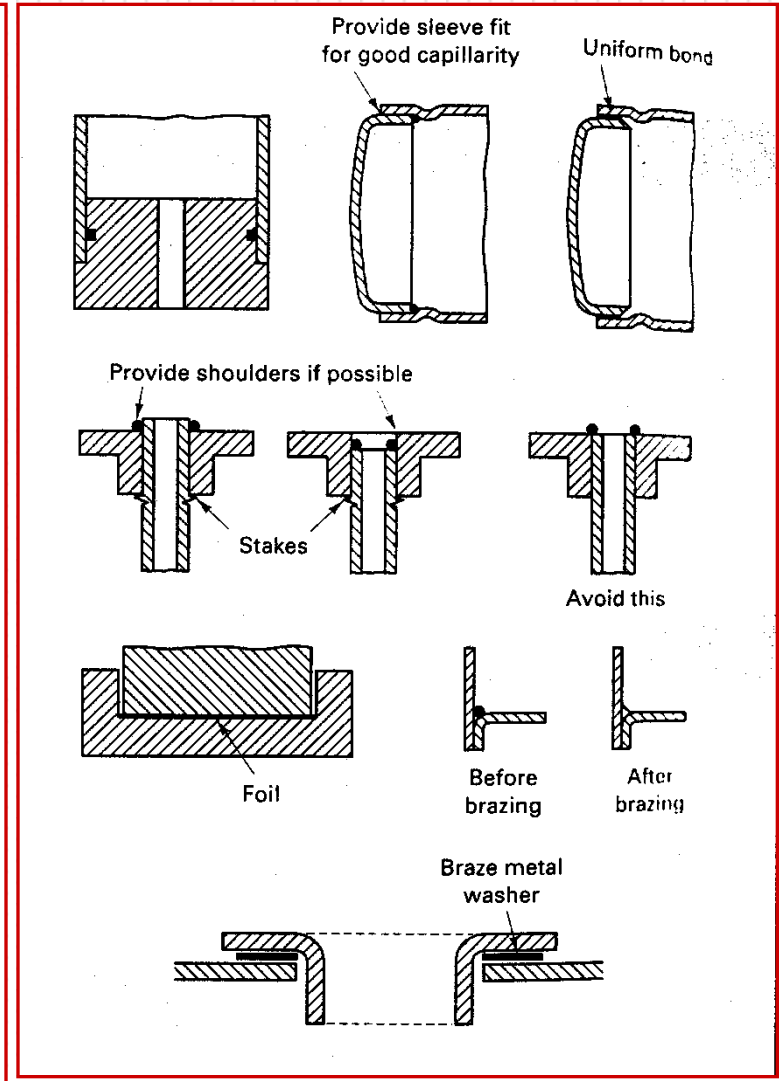

Brazing and Soldering

2. Soldering

*Melting temperature of solder material, called **solder**, is below 450°C (The 450°C, which is an arbitrary value, is set to distinguish brazing from soldering).*

*Solder materials are, **alloys of lead and tin** with the addition of a very small amount of **antimony**.*

*There is no coalescence, **bond strength is relatively low**, the joining being effected by **adhesion** between the solder and the parent metal (**mechanical bonding**).*

Soldering

Heating Methods used for Soldering

1. *Electric soldering irons or guns*
2. *Dip soldering*
(e.g. electronics work, automobile radiators)
3. *Induction heating*
(Used for a large number of identical parts)
4. *Heating by infrared sources*
(For low melting point solders)
5. *Furnace heating (Seldom used)*
6. *Salt-bath heating (Seldom used)*

