

Wind-tunnel techniques

By

Dr. Sangram Samal

What is a wind tunnels?

A wind tunnel is a tube or tunnel that has man-made wind blown through it at a certain speed. Scientists and engineers put a model of an airplane in the tunnel and then study the way the air moves around the model.

What is the purpose of a wind tunnel?

- A wind tunnel is used to simulate air flow over a model of an airplane or a wing section so it can be studied.
- The model can be instrumented to measure the lift and drag and other parameters for study.
- The wind tunnel can produce air flow at the desired speed and condition.
- Engineers may use a wind tunnel to study and design a wing shape.
- Wind tunnels can be used to study interference between parts of the aircraft or between an airplane and a bomb as it drops away.

What are types of wind tunnels

Wind tunnel can be classified by size, test section velocity and working principle.

- The wind tunnels come in a lot of sizes. Some are only a few inches square, and some are large enough to test a full-size airplane.
- Identification of W/T may be made through the cross sectional from the test section. It may square, rectangle, octagonal, circular, elliptic
- Also classified with velocity as: low speed wind tunnels, supersonic wind tunnels and hyper-sonic wind tunnels.
- Blower (Fan is ahead of test section) and suction type (Fan is after the test section)
- There are two basic types of wind tunnels
 - **Open-Circuit (or 'Eiffel' or 'NPL') wind tunnel**
 - **Closed Test Section / Open Test section**
 - **Closed-Circuit wind tunnel**
 - **Closed Test Section**

Example

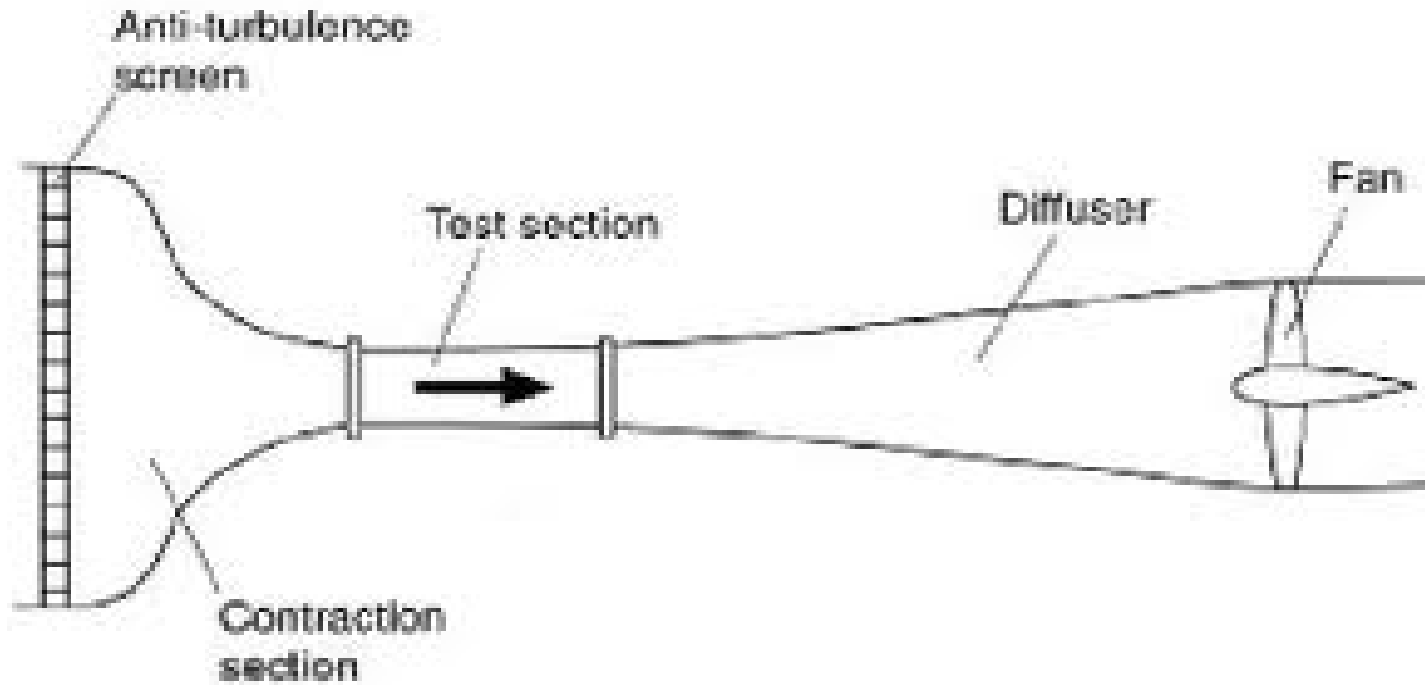

Open-Circuit Wind tunnel



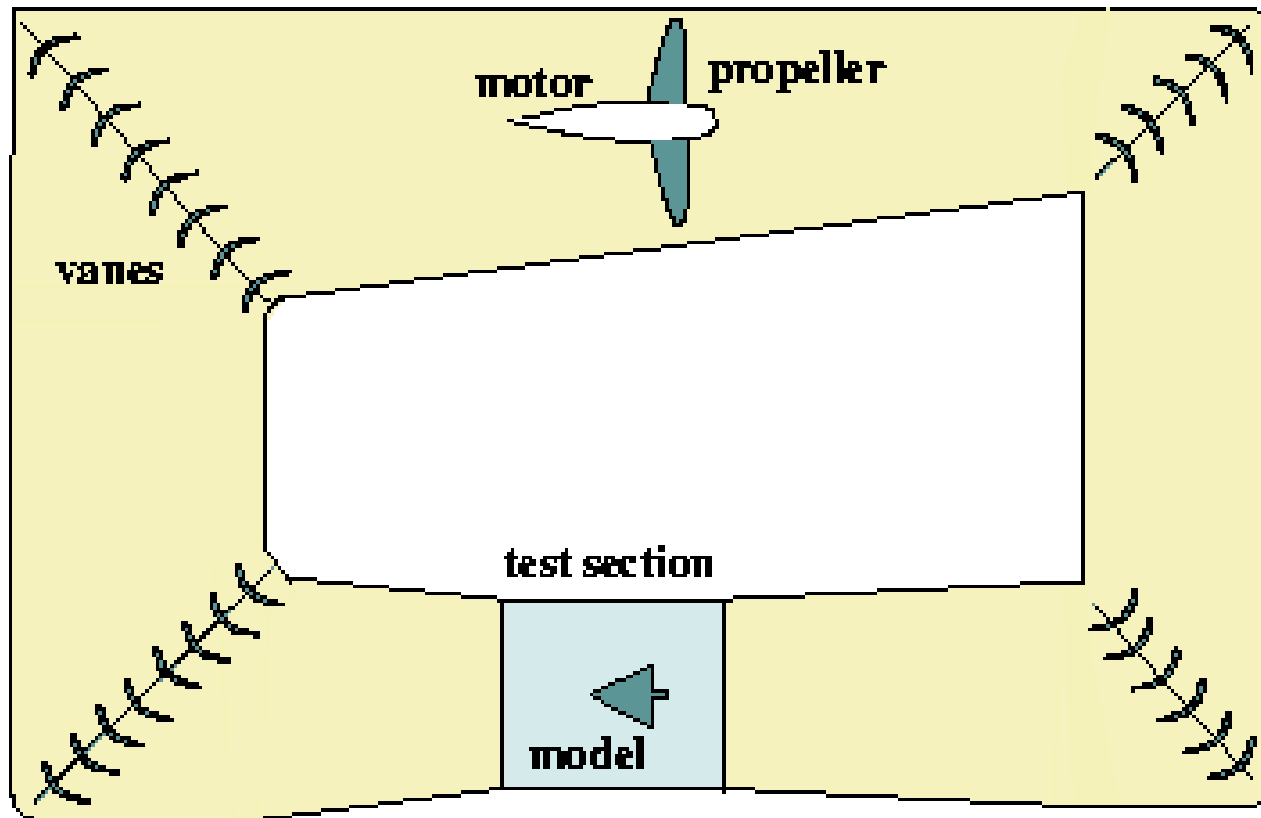

Closed-Return Type Wind-Tunnel

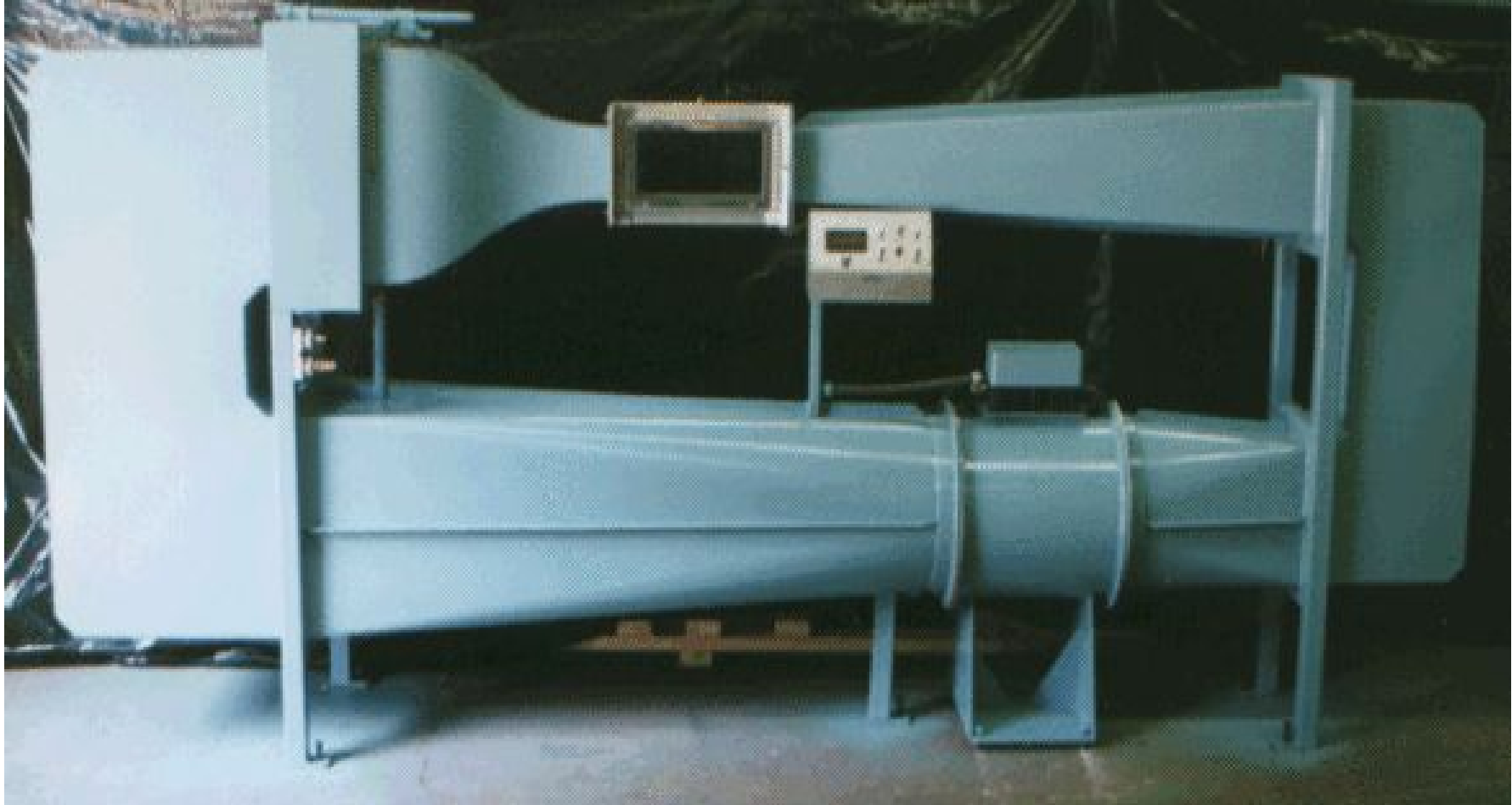



NASA AMES RESEARCH CENTER'S 80 FT X 120 FT OPEN-CIRCUIT "SUCKDOWN" TUNNEL, WITH SIX FAN AT EXIT

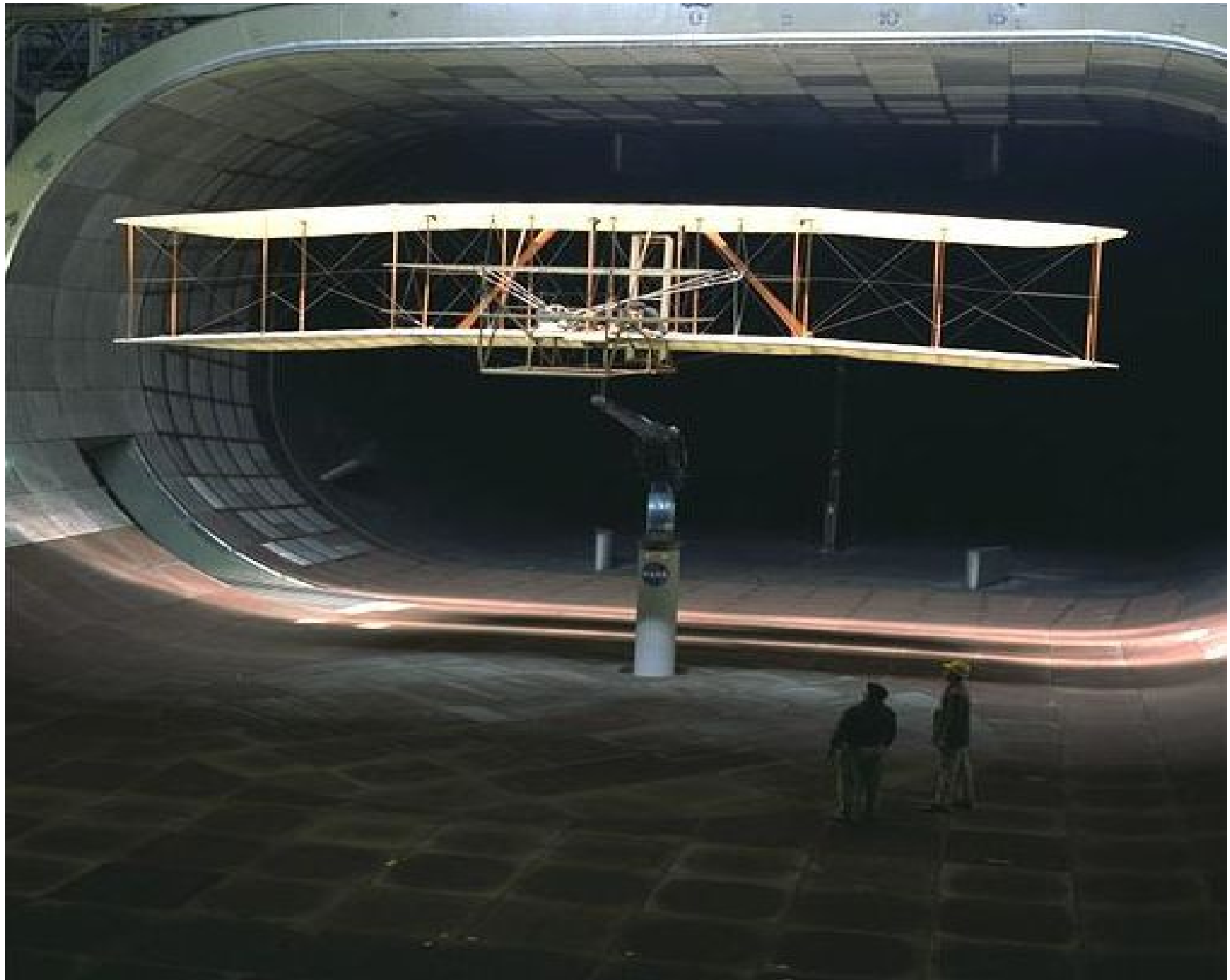

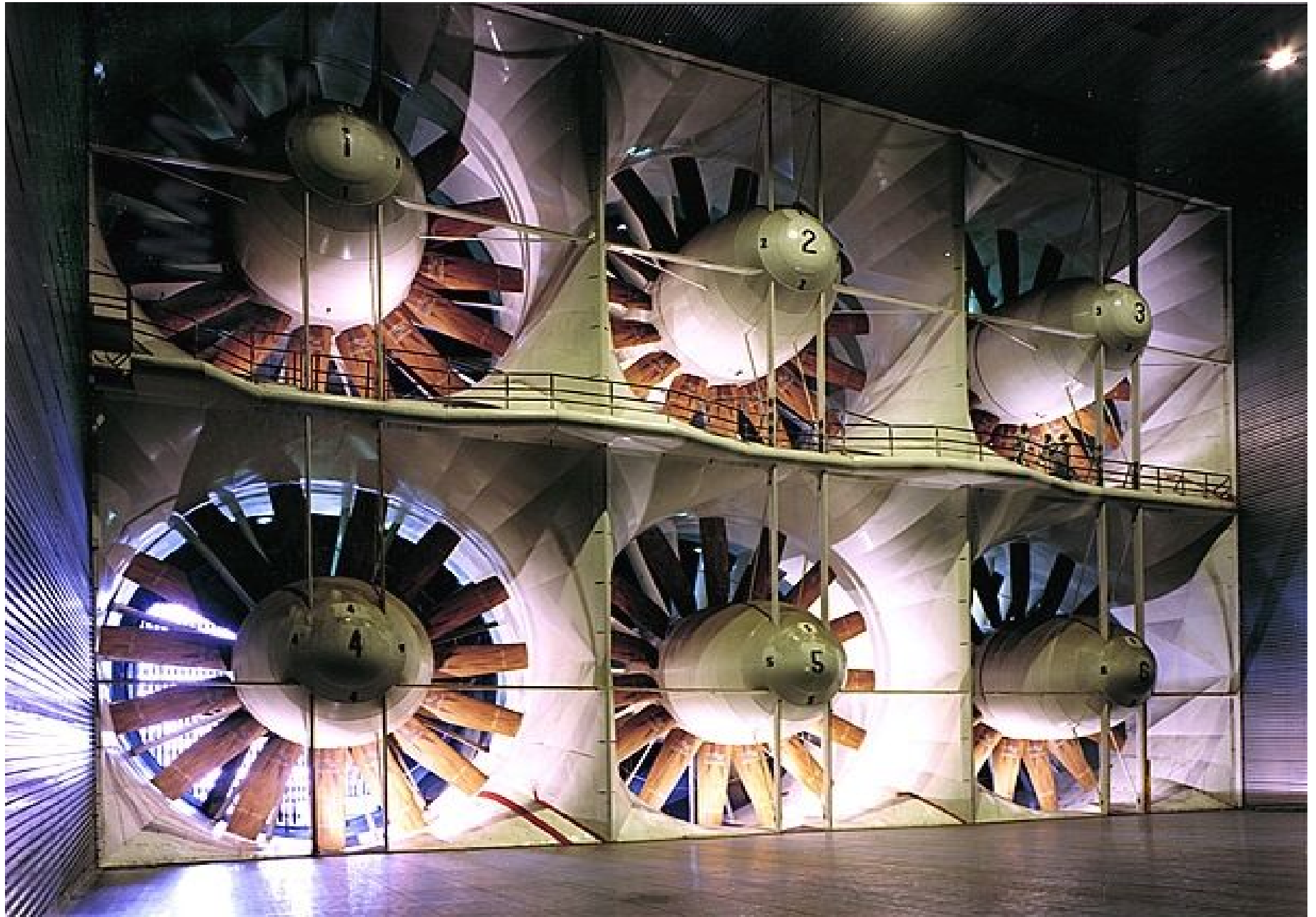

Drive fans in the NASA Ames NFAC

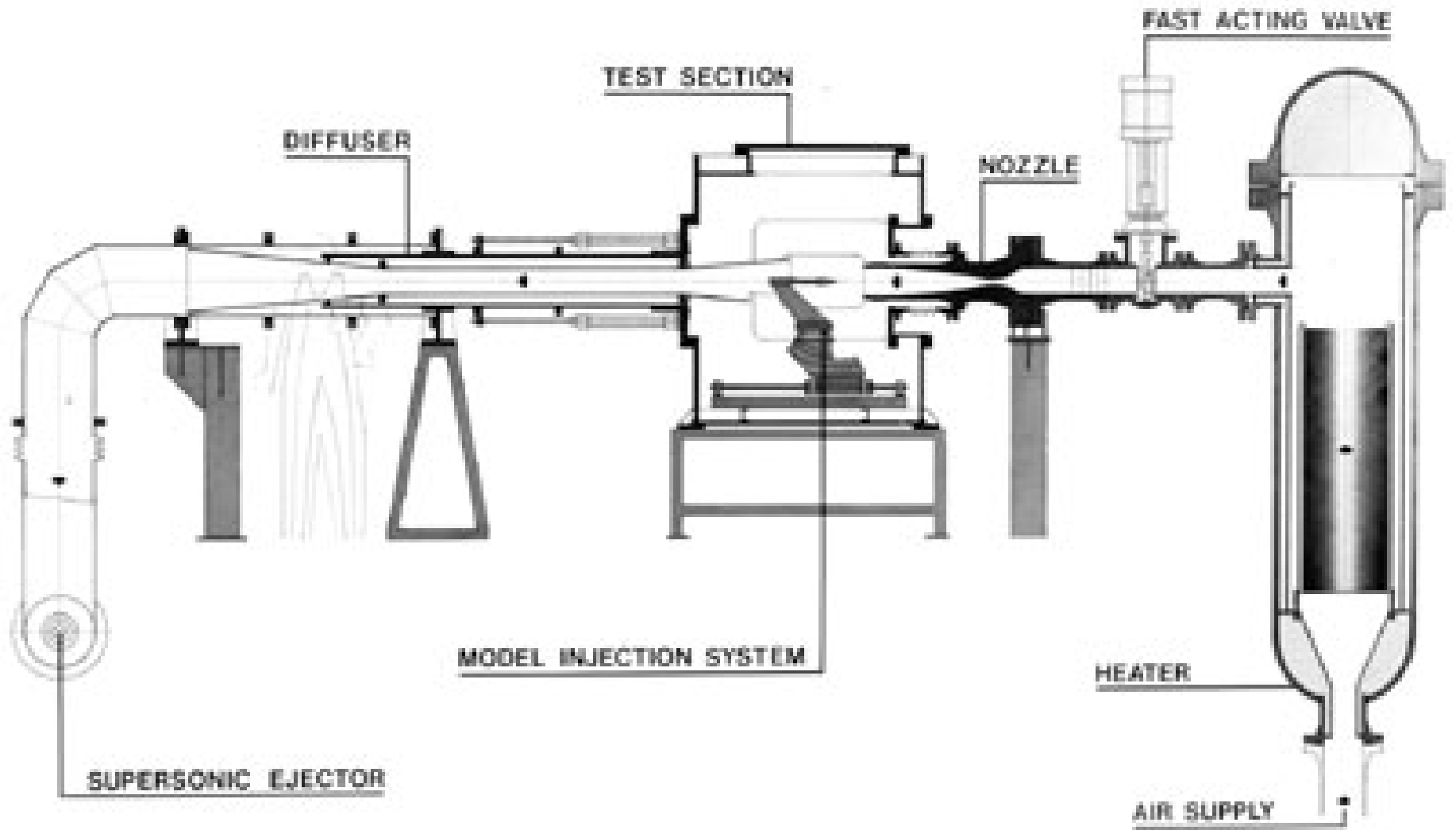

Blow-Down Type Tunnel



Boeing 757 Model in NASA Langley 14x22-Foot Wind Tunnel



Full-Scale Test of F-18 in NASA Ames 80x120-Foot Tunnel

Closed Circuit wind tunnel

Following are three types of closed circuit W/T

- Single closed circuit
- Double closed circuit
- Annular closed circuit

Single closed circuit

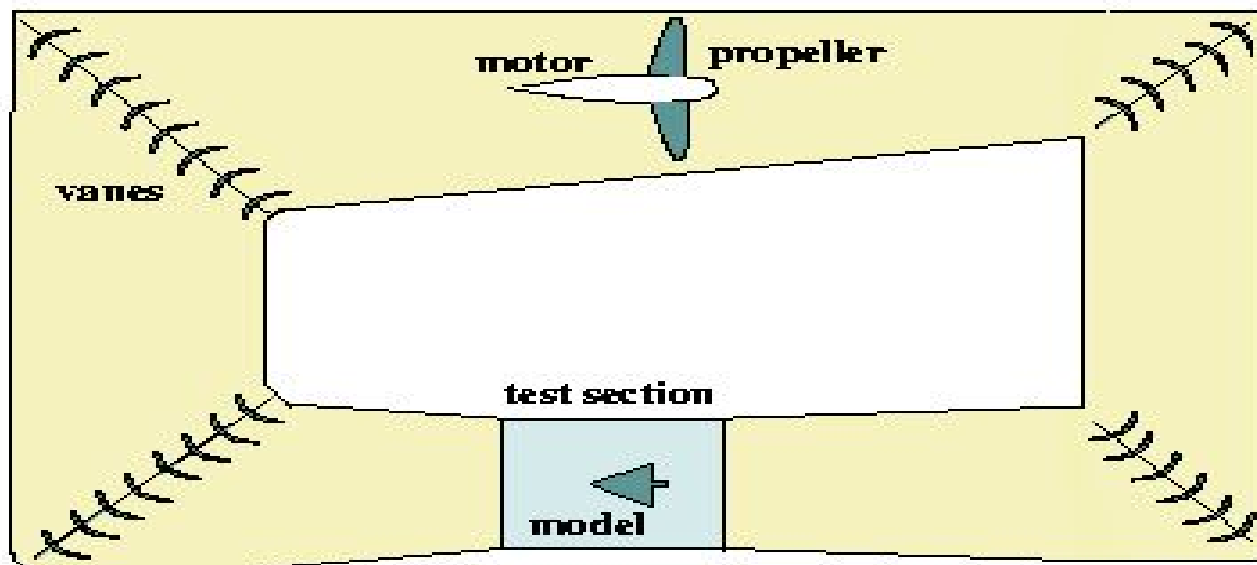

Annular Return circuit W/T

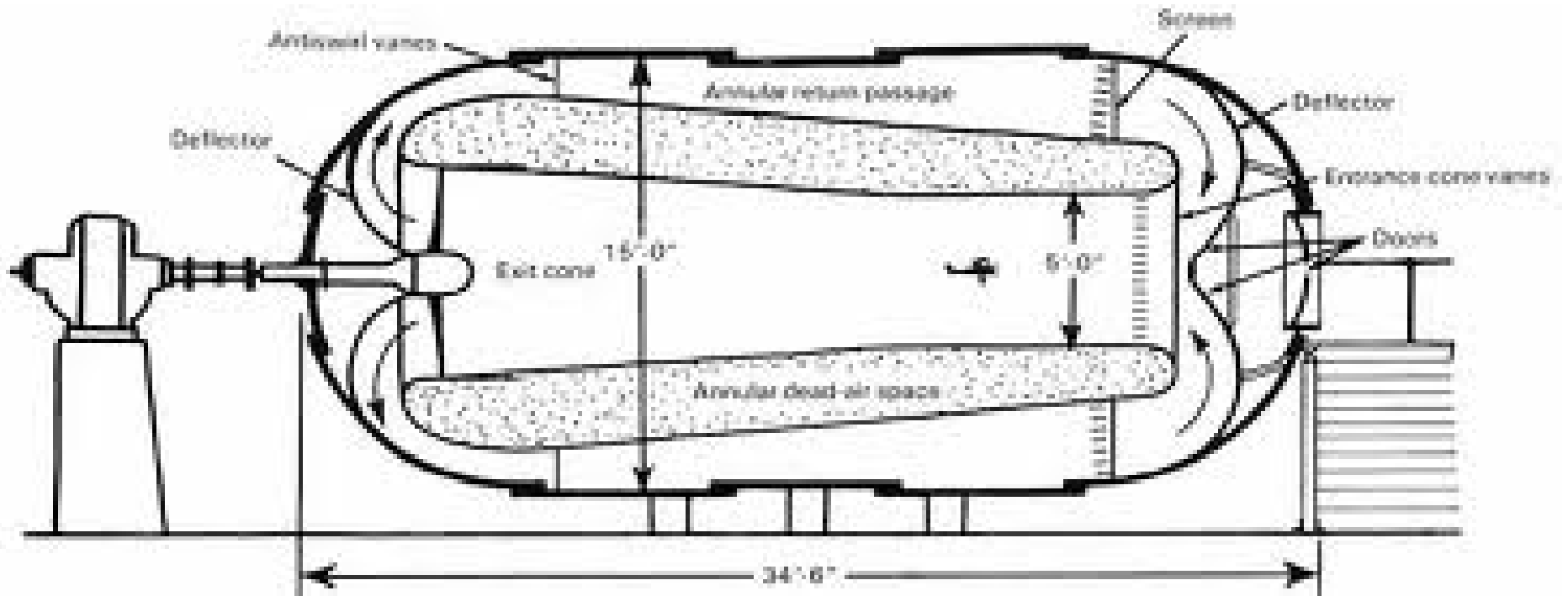

Difference between open and closed circuit type W/T

- Open circuit wind tunnel uses fresh air from atmosphere
- Test section temperature, density and pressure depend on the atmospheric condition In case of open tunnel.
- In case of close circuit above can be controlled.
- The atmospheric gust can cause variation in test section dynamic pressure in case of open type W/T
- The test section can be kept open in case of Open circuit W/T (called 'Eiffel' tunnel)
- Open circuit W/T is noisy, depend on out side weather condition.
- There may be chance of coming the dust, Insects and birds inside to tunnel in case of open circuit W/T
- The fans can damage due to model failure in case of open circuit W/T

Difference between single and double, annular type W/T

- Only the single type W/T is in general acceptance at present
- The Double and annular type the air is extremely turbulent. So difficulty to find out test data.
- Disadvantage of the double return type is that a variation in velocity may cause to yaw the model inside test section.
- In double return type flow deflection may not symmetrical , which can cause the yaw or roll to model

Other different type of W/T

Variable Pressure Tunnel (Return)

- This type of W/T , pressure can be maintained higher or lower than atmospheric pressure
- It required some time to build the required pressure before start the W/T
- Mach no and Reynolds number can be changes using different pressure.

Variable Density Tunnel (Return)

- This tunnel can attend high Reynolds number without either very high speed or large model
- This tunnel is no longer used because of high turbulence. Reynolds number can increase by blowing the air from pressure reservoir for a small W/T

Different type of W/T

Full-scale Tunnel

- This is capable of testing actual airplane of moderate size.
- This tunnel needs more power to run

Smoke Tunnel

- This type of tunnel is low speed W/T
- Smoke is used to see flow patterns over the model

Free-Flight Tunnel

- No balance is required
- Model is controlled remotely

Spin Tunnel

- This is a special type of W/T that has a flow in the test section which is vertically upward and of sufficient speed to suspend the a/c and spin for observation.

Two Dimensional Tunnel

- The test section of this type of model is quite **flat** to test only 2-D model

Other types of tunnels are Ice Tunnel and water tunnel

Design Parameter of wind tunnel

- Purpose (Type of testing: Flow pattern over the model, Spinning of a/c, Full scale, 2-D, ect..)
- Shape of test section
- Test section Velocity
- Atmospheric or closed
- Physical location where W/T will be placed. (length, width, direction of air flow, surrounding, ect need to be considered)
- Price (Budget) allocation for w/t
- Operating costs (Estimate number of hours need to run)
- Also losses in the test section, corners, diffusers, and entrance are calculated and summed up to get the input power.

The test section (Jet) designing

- This will take care the size and wind speed of the test section.
- Consideration of the power. To maintain the same Reynolds number a tunnel can use greater size (twice a given size) at a lower speed (half of a given speed). This way higher speed tunnel will use four time power of the smaller velocity tunnel.
- The test section shape can be selected for many different cause. – Round, square, rectangular, rectangular with tampered corner, Round with flat floor, elliptical with flat floor.
- Keep in mind that the power is depend directly the test section area (neglecting skin friction for various shape) not with the shape
- The greatest width section could test the largest span model. But above 7 to 10 height-width ratio the tunnel wall effect will be on the model.
- The curved test section (circular, elliptical) will not have losses due to corner. But difficult to fix the model compare with flat floor.
- For attaching testing equipment and better test section view, the flat ceiling and flat wall is better than the curved cross section
- Curved test section is very difficult to designee compare to rectangular cross section

- The length of test section varies from one to two times of (Height or width)
- The power can be saved keeping the smaller length
- As the test section length increase, the velocity increase (static pressure drop) towards to end of the test section due to B/L growth. This causes the horizontal buoyancy (additional drag) on model
- To avoid the horizontal buoyancy, about $\frac{1}{2}$ deg divergence may be given to each wall or B/L suction method should used to maintain constant B/L thickness in test section
- The test section or jet need to be design considering the sufficient window to view the model
- In open test section, the wind tunnel balance and other instrument is very easy to install with compare to the closed test section
- The power required for the open test section is more (three time) than the closed test section for same speed and size
- The size of exist cone should be more than the entrance cone in case of open jet
- The open jet is used in open circuit wind tunnel

The Return Passage

- The return passage or diffuser plays a major role on power saving
- Power losses in a wind tunnel vary with cube of the air speed at fan
- It is desirable to increase the cross sectional area of return passage as rapidly as possible to reduce the velocity and hence the power losses
- The rate of this area increase is limited otherwise flow will separated from walls will cause large losses
- The divergence angle of diffuser should be 5 to maximum 7 degree.
- Smaller diffuser angle make larger diffuser length cause more cost
- Wider diffuser angle less length of W/T but flow (B/L) is separated which causes losses.
- To prevent B/L separation the screen, vortex generators, splitter plate and boundary layer control technique can be used
-

The Breather

- This used to reduce the vibration inside the test section
- This is keeping a slot (about 0.05 diam wide) into the diffuser which connected it to the atmosphere. Such arrangement is called 'Breather'
- Special effort should be made to keep vibration out the test section and balance supports

The Fan Flow and Straightener System

- The fan should be located downstream of the second corner of the closed-circuit W/T
- The argument for positioning after the second turn is that the flow has by then been in constant area for considerable time and therefore should be relatively smooth when it meets the fan
- Three basic fan-straightener systems are used.
 - A Fan with straightener vanes behind of the fan
 - A fan with pre-rotating vanes ahead of it with above system
 - Counter rotating fans in which the second fan removes the rotation created by the first
- The counter rotating fan can remove all the twist in all the speed. Two fan need to be designed to develop more thrust and equal thrust should be applied to both fans
- Fans with pre-rotating vanes can develop more thrust for a given blade area because initial rotation increase the total velocity of the airstream
- Disadvantage of pre-rotating vanes is that can not pre rotate at proper rpm at different power of main fan
- The variable pitch fan will have good efficiency at variable speed.

Fan with straightener vanes

- A fan with pre-rotating vanes



Counter rotating fans

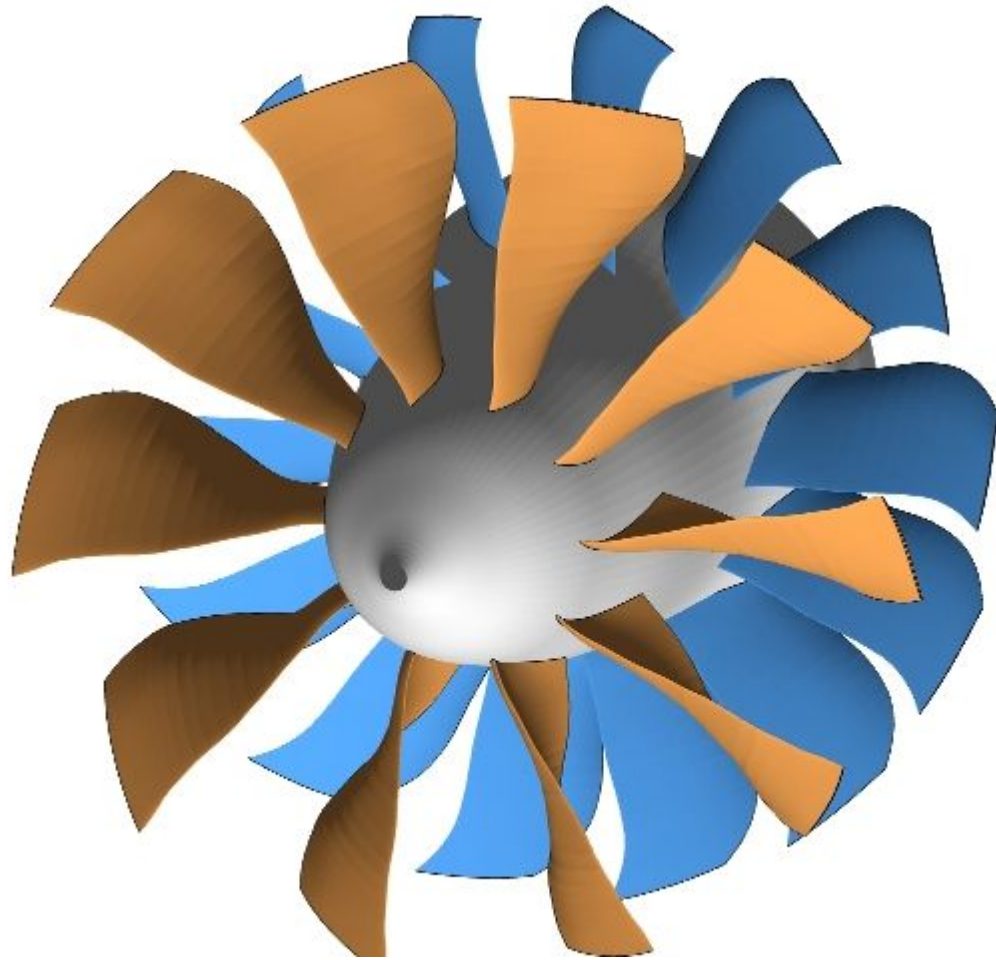

The Drive motor and Fan

- The thrust of the fan and drag components vary with the square of the fan rpm
- Velocity in test section can be adjusted using varying fan rpm or changing the pitch angle of the fan
- Most of the W/T speed is controlled using the fan RPM
- Different type of motor is used to rotate the fan (d-c motor, variable frequency, Magnetic coupling, induction motor, Internal combustion drive motor, ect...)
- The nacelle must be from 0,3 to 0,7 diam in order to give the best flow condition for the fan

The corners

- Practically it is not possible to design the corners without losses.
- Using proper turning vanes the losses can reduce
- Drag due to separation $\eta = \Delta p / q$
 - η = corner losses coefficient
 - Δp = static pressure drop due to losses
 - q = dynamic pressure
- The abrupt corner gives 100 % ($\eta = 1.00$)
- With good designing this can be reduce to 0.15

The Honeycombs and Screen

- Honeycombs and screen are used in the settling chamber to improve the flow and reduce the turbulence of the air
- Disadvantage of honeycomb is reduce the area (surge)
- Different type of honeycombs are square, rectangle, octagonal
- Disadvantage of honeycombs, add the blockage to air flow at entrance
- Screens are far more useful than honeycombs for adjusting the flow
- Low turbulence tunnel might have six or more screens inside the settling chamber

Entrance Cone

- Use between settling chamber to the test section to increase velocity
- Bad designing of entrance cone can cause the flow separation before the test section
- Boundary layer growth of cone can be avoided at test section keeping very small gap (of 0.05 diam) just before test section
- Contraction ratio and length of cone need to be design properly to get required velocity at test section without boundary layer separation from cone

Power Losses

- A logical approach to the losses in wind tunnel- Break down the tunnel into following parts
 - Cylindrical section
 - Corners
 - Expanding Section
 - Contracting section
- Calculate the losses for each section
- This excluded the losses from fan and motor efficiency

Cooling

- Due to motor (propeller driven) there is increase in temperature in the flow
- For low power tunnel with open jet this effect is very low
- For tunnel with high power input and high jet velocity this effect can be more
- For this type of tunnel the cooling may be done by any of the four methods:
 - Increase of surface cooling by running of water over the tunnel exterior
 - Interior cooling by the addition of water cooled turning vanes
 - Water cooled radiator in the largest tunnel section
 - By Continuous replacement of heated tunnel air with cool air using air exchanger

Jet Inserts

- Tunnel can have auxiliary test section which can be fitted inside the normal test section to reduce the test section size to save the model cost or increase the velocity
- This test section are usually either end plate or contraction types.

Calibration of the test section

- Speed
- Boundary layer growth
- Yaw of air

- Two types : open circuit and closed circuit

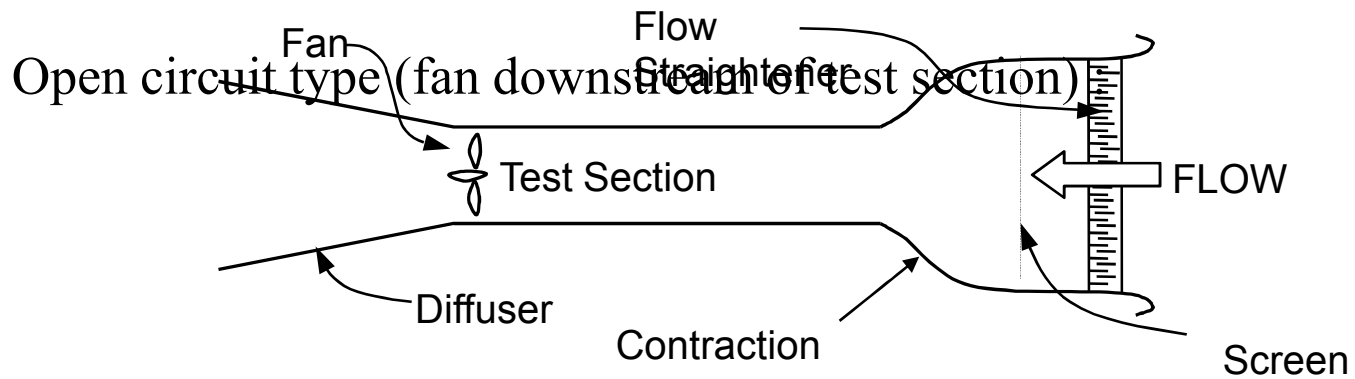

Blowing type - fan upstream of test section :

test section nearly at atmospheric pressure

Wind-tunnel techniques

- Simulation of atmospheric boundary layer :

Natural growth method :

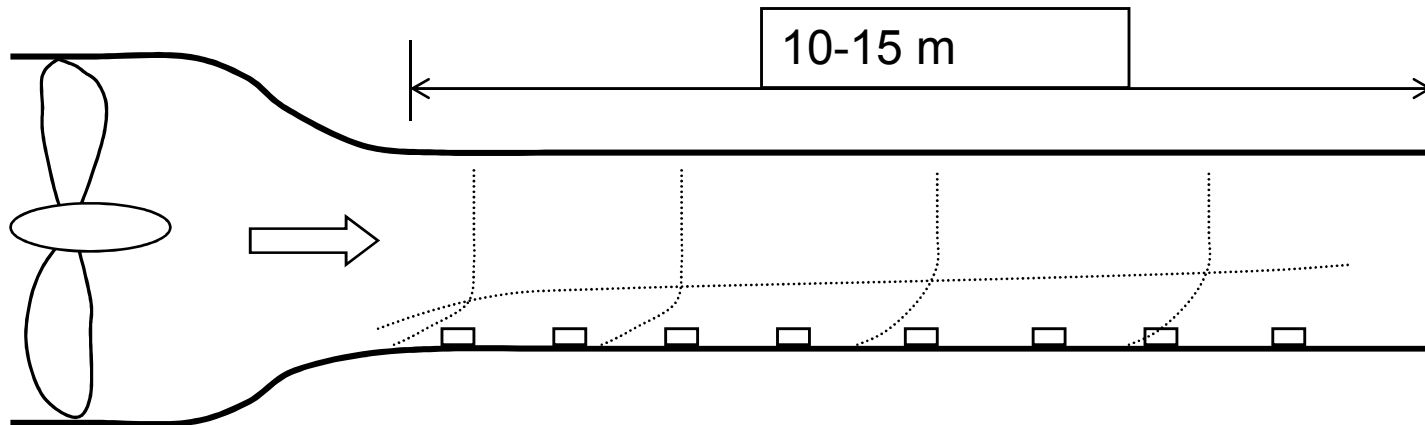

Boundary layer is grown naturally over surface roughness elements

Boundary layer thickness is usually too small to model complete atmospheric boundary layer - use auxiliary 'tripping' devices

Wind-tunnel techniques

- Simulation of atmospheric boundary layer :

Methods for short test sections :

Counihan method

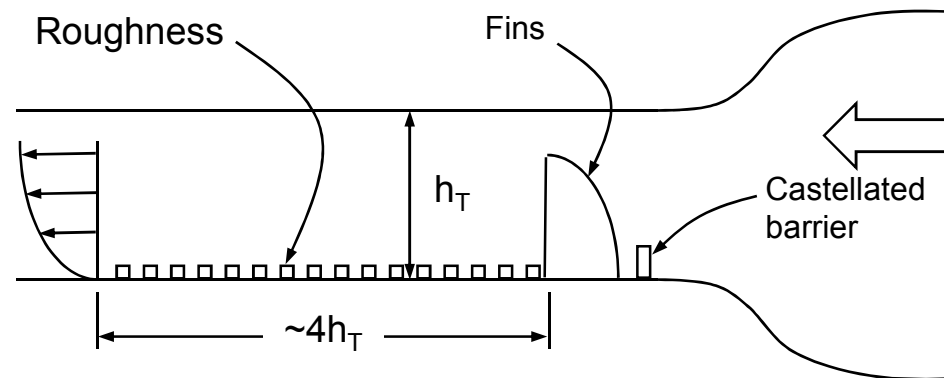

Other devices : triangular 'spires', graded grids

Wind-tunnel techniques

- Simulation of 'surface layer' (<100 m) :

Barrier - roughness :

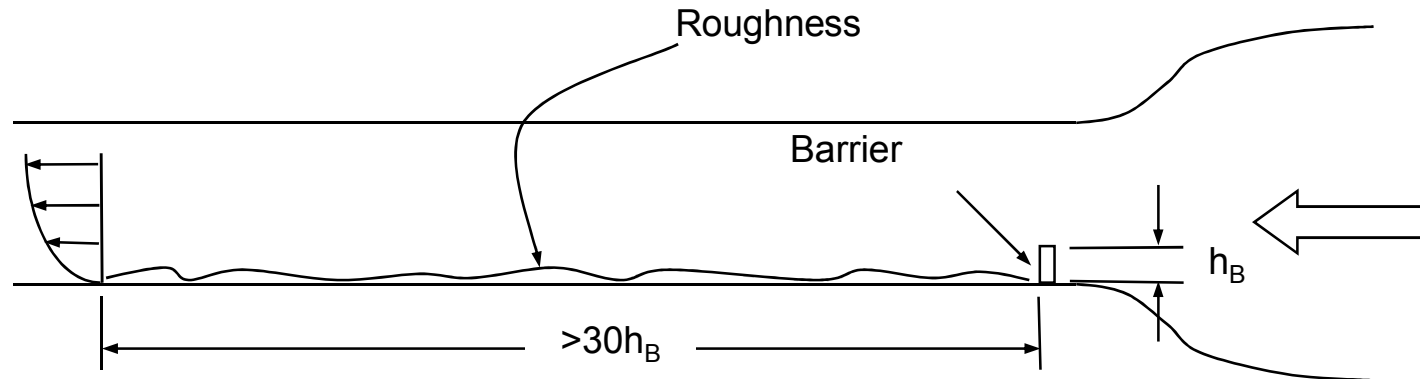

Eddy size (\approx integral length scale) larger than other methods

Useful for model scales of 1/50 to 1/200 (e.g. low-rise buildings)

Wind-tunnel techniques

- Simulation of hurricane boundary layers :

Near eye wall : steep profile up to about 100 metres - then nearly constant

Turbulence is higher in hurricanes (but 'patchy')

Can use non-hurricane boundary layer for rougher terrain in wind tunnel simulations

Wind-tunnel techniques

- Simulation of thunderstorm downburst by impinging jet :

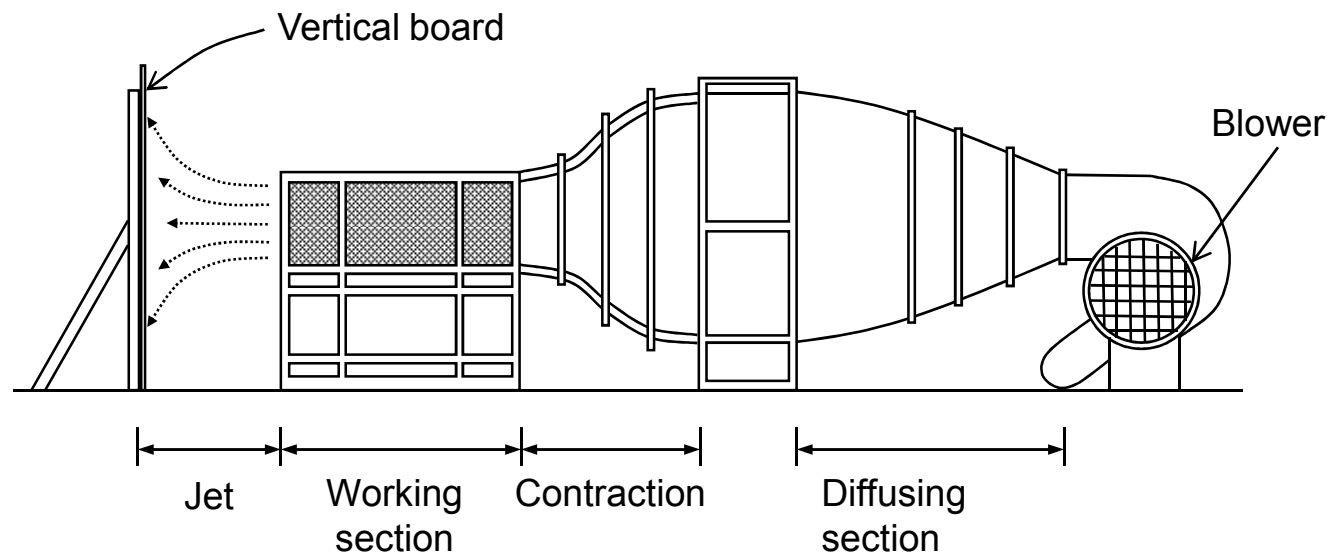

Stationary downbursts only are modelled - continuous not transient

Wind-tunnel techniques

- Modelling rules - dimensional analysis :

Non-dimensional response/pressure coefficients =
 $f(\pi_1, \pi_2, \pi_3 \text{ etc...})$

π 's are non-dimensional groups associated with flow and structure

π 's should be matched in full scale and model scale

Examples of π 's :

I_u, I_v, I_w - turbulence intensities

Uh/ν - Reynolds Number (ν is kinematic viscosity)

$E/\rho_a U^2$ - Cauchy Number (elastic forces in structure/inertial forces in flow)

ρ_s / ρ_a - density ratio (density of structure / air density)

Wind-tunnel techniques

- Modelling rules - dimensional analysis :

Non-dimensional numbers may not be independent

For example, reduced frequency :

$$\frac{n_s L}{U} = K \sqrt{\frac{E}{\rho_s L^2}} \cdot \frac{L}{U} = K \sqrt{\frac{E}{\rho_a U^2}} \cdot \sqrt{\frac{\rho_a}{\rho_s}}$$

i.e. proportional to square root of the Cauchy Number divided by the density ratio

Wind-tunnel techniques

- Modelling rules - dimensional analysis :

Not possible to obtain equality of all non-dimensional groups

Scaling requirements might be relaxed

Judgement based on experience and understanding of mechanics of the phenomena

Quality assurance manuals and standards for wind-tunnel testing are now available - e.g. A.W.E.S. , A.S.C.E.

Wind-tunnel techniques

- Measurement of local pressures :

Fluctuating and short duration peak pressures must be measured

Local pressures - measurement done with single measurement 'tap'

Area-averaged pressures with multiple pressure taps manifolded together

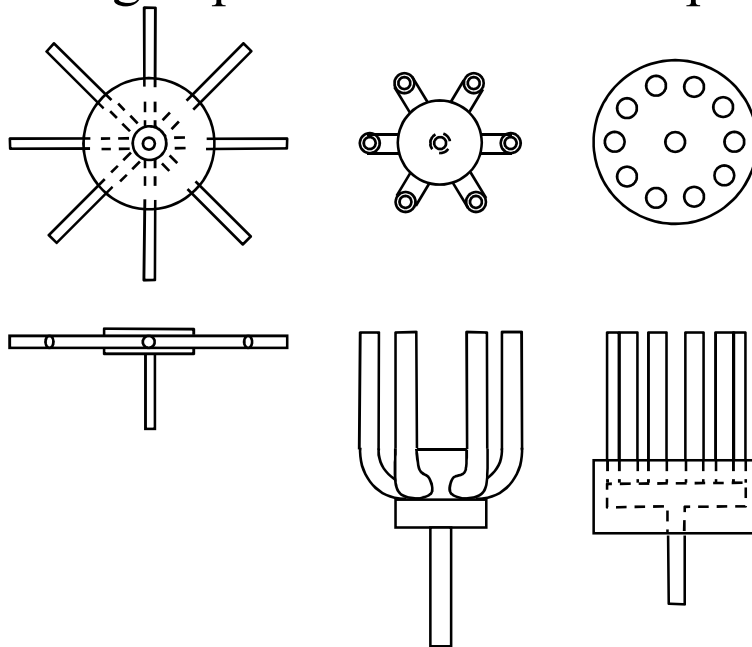

Multiple input tubes -
single output tube to
electronic pressure sensor

Wind-tunnel techniques

- Area-averaged pressures :

Discrete averaging overestimates continuous average fluctuating loads

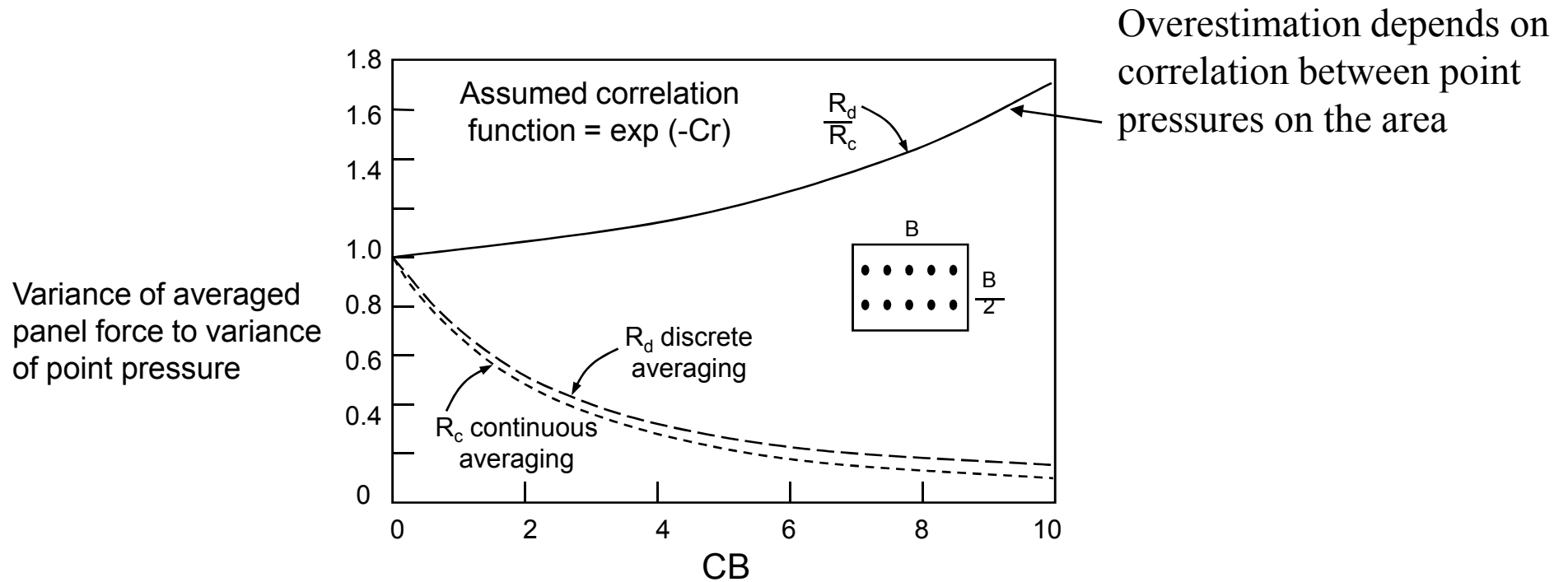

Wind-tunnel techniques

- Frequency response of measurement system :

Require amplitude response ratio equal to 1.0 (+/- small error) over a defined frequency range

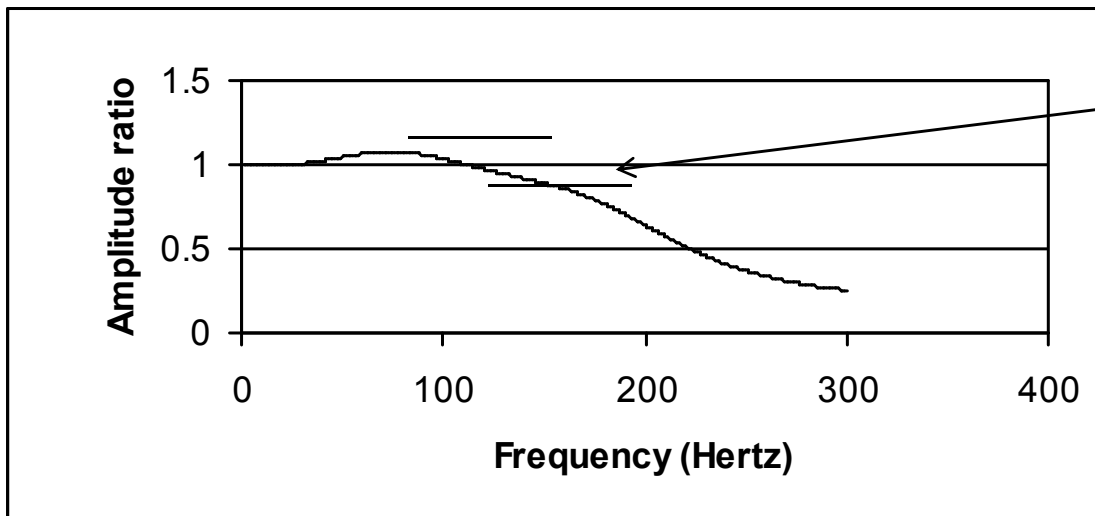

System within +/- 15%
limits to 150 Hertz

Wind-tunnel techniques

- Frequency response of measurement system :

Require phase response to vary linearly over a defined frequency range

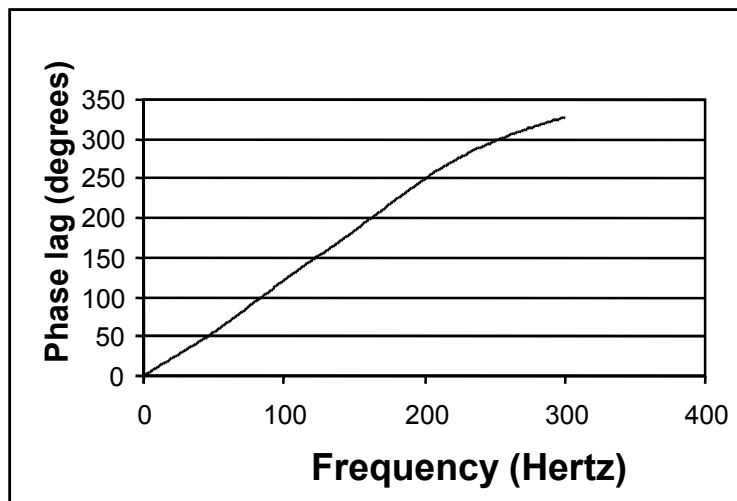

$$\text{Time delay} = \frac{1}{n} \times (\text{phase angle} / 2\pi)$$

For constant time delay, phase angle should be proportional to frequency, n

Wind-tunnel techniques

- Types of tubing systems :

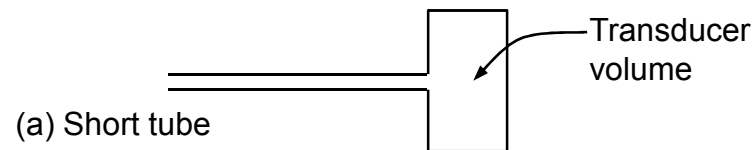

Short tube : high resonant frequency
but amplitude response rises fast

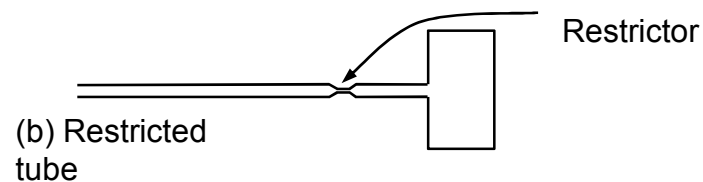

Restricted tube :
restrictor tube damps resonant peak

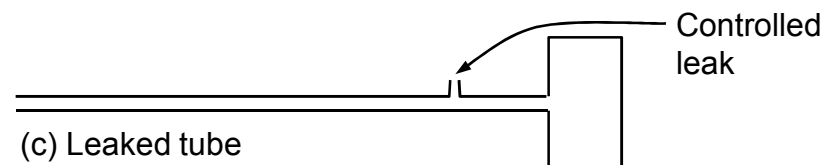

Leaked tube :
high pass filter, mean response is
also reduced

Wind-tunnel techniques

- Overall loads on tall buildings :

Two techniques : aeroelastic models - resonant structural response is scaled

motion of building in sway modes of vibration are reproduced - hence aeroelastic (e.g. aerodynamic damping) forces are included

Base-pivotted aeroelastic model :

Uses equivalence of rigid body rotation and movement of tall building in first mode with linear mode shape

Model should be scaled to have the same density

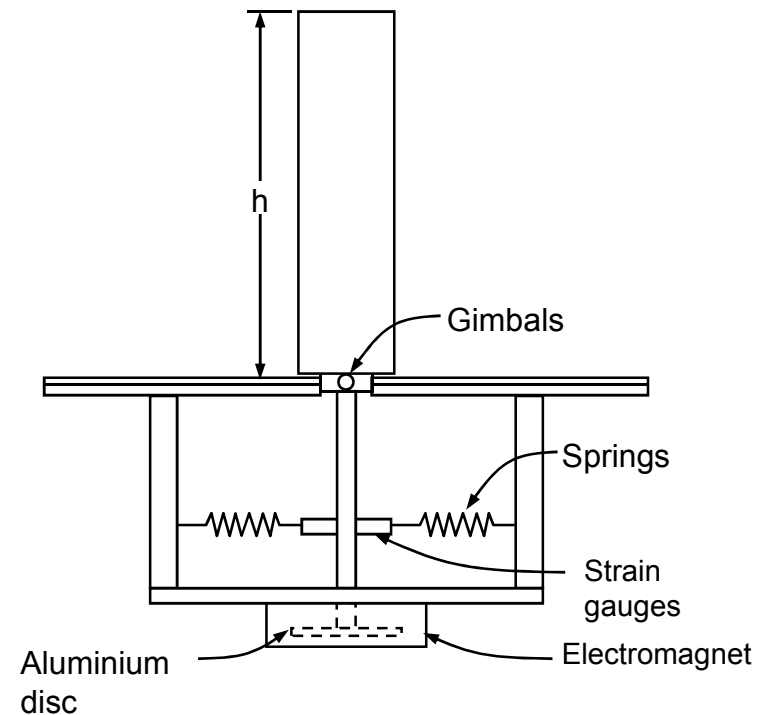

Wind-tunnel techniques

- Overall loads on tall buildings :

high-frequency base balance :

mean and background aerodynamic forces only are measured

model building supported on a stiff
base balance to measure
aerodynamic applied forces

spectral densities of applied base
bending moments are measured and
used to compute resonant
components in sway modes

requires mode shape corrections,
special processing for coupled
modes, linked buildings

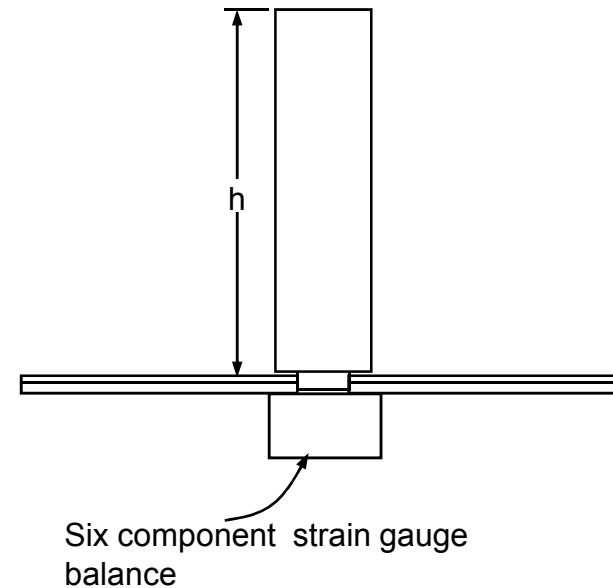

Wind-tunnel techniques

- High-frequency base balance :

Frequency relationships :

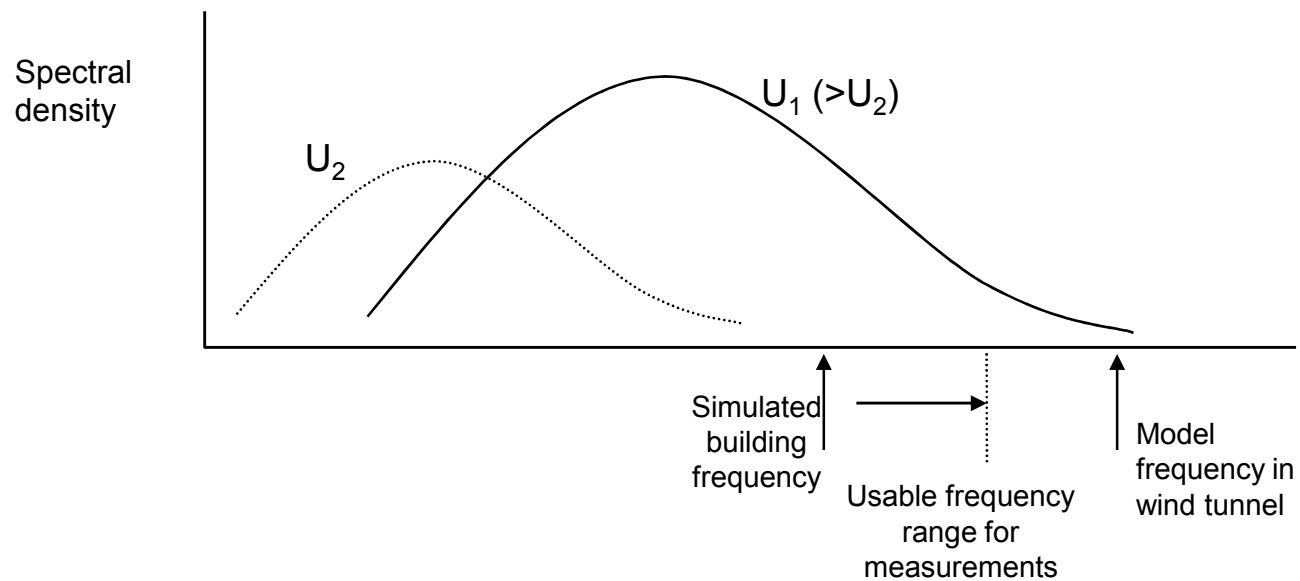

Support system should be made very stiff, and building model light to keep frequency above measurement range

Wind-tunnel techniques

- Full aeroelastic models :

Slender structures such as bridges and towers

Elastic properties are concentrated in a 'spine' to which non-structural segments are attached to give correct aerodynamic shape and mass

Length scale ratio and velocity scale ratio chosen to suit size and speed range of wind tunnel

Frequency then obtained by equality of reduced velocity :
$$\left(\frac{n_s L}{U}\right)_m = \left(\frac{n_s L}{U}\right)_p$$

Stiffness of spine obtained by requirement to keep frequency of structure equal in model and full scale

Wind-tunnel techniques

- Full aeroelastic models :

Segmented tower legs and deck



End of Lecture 17

John Holmes

225-405-3789 JHolmes@lsu.edu