

Ansoft EM Solvers Maxwell vs HFSS

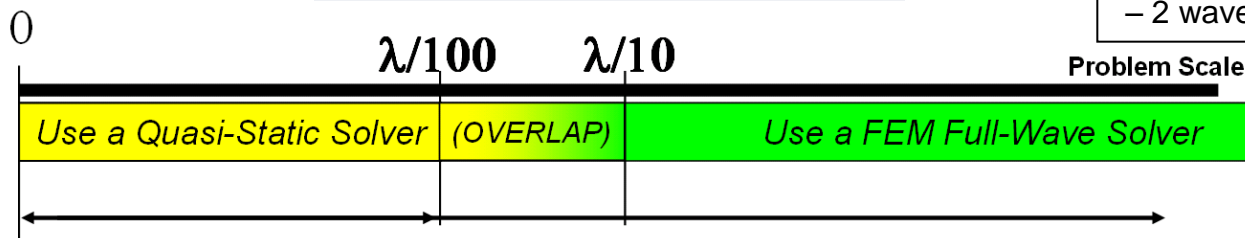

- ▲ When the Electrical Length (in wavelengths) requires phase consideration
 - ▲ $\lambda/10$ is a guideline; there are exceptions
- ▲ When radiation from the device must be considered
- ▲ When S-Parameters are the desired output
- ▲ When lossy dielectric materials have significant effects

Differential Form of Maxwell's Equations

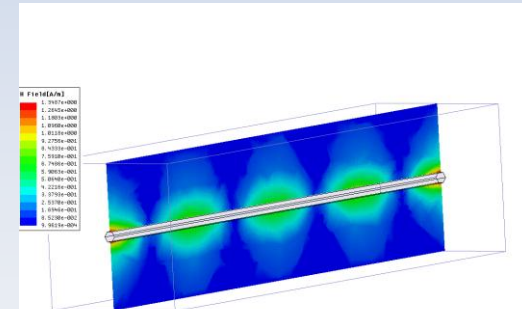
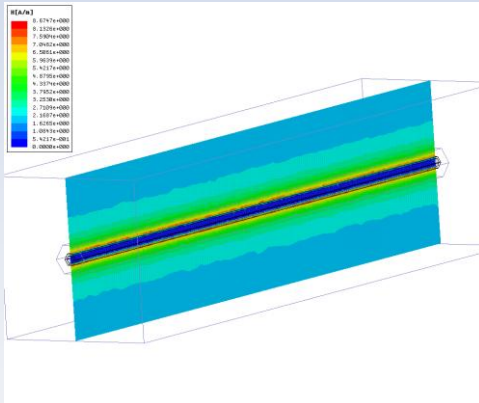
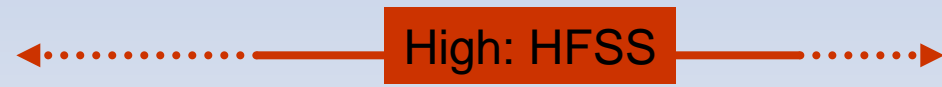
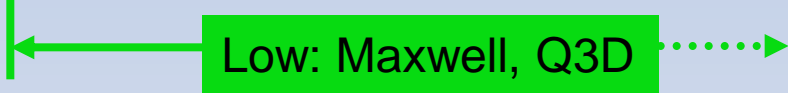

Full-wave (e.g. HFSS)

Faraday's Law of Induction $\nabla \times E = - \frac{\partial B}{\partial t}$

Gauss' s Law for Magnetism $\nabla \bullet B = 0$

Ampere's Law $\nabla \times H = J + \frac{\partial D}{\partial t}$

Gauss' s Law for Electricity $\nabla \bullet D = \rho$

Example: Maxwell: Magnetic Transient Formulation



Faraday's Law of Induction $\nabla \times E = - \frac{\partial B}{\partial t}$

Gauss' s Law for Magnetism $\nabla \bullet B = 0$

Ampere's Law

~~$\nabla \times H = J + \frac{\partial D}{\partial t}$~~

Quasi-Static:
e.g. Maxwell,
Q3D

Gauss' s Law for Electricity

~~$\nabla \bullet D = \rho$~~

Variable-Speed Drive Classical Design Issues

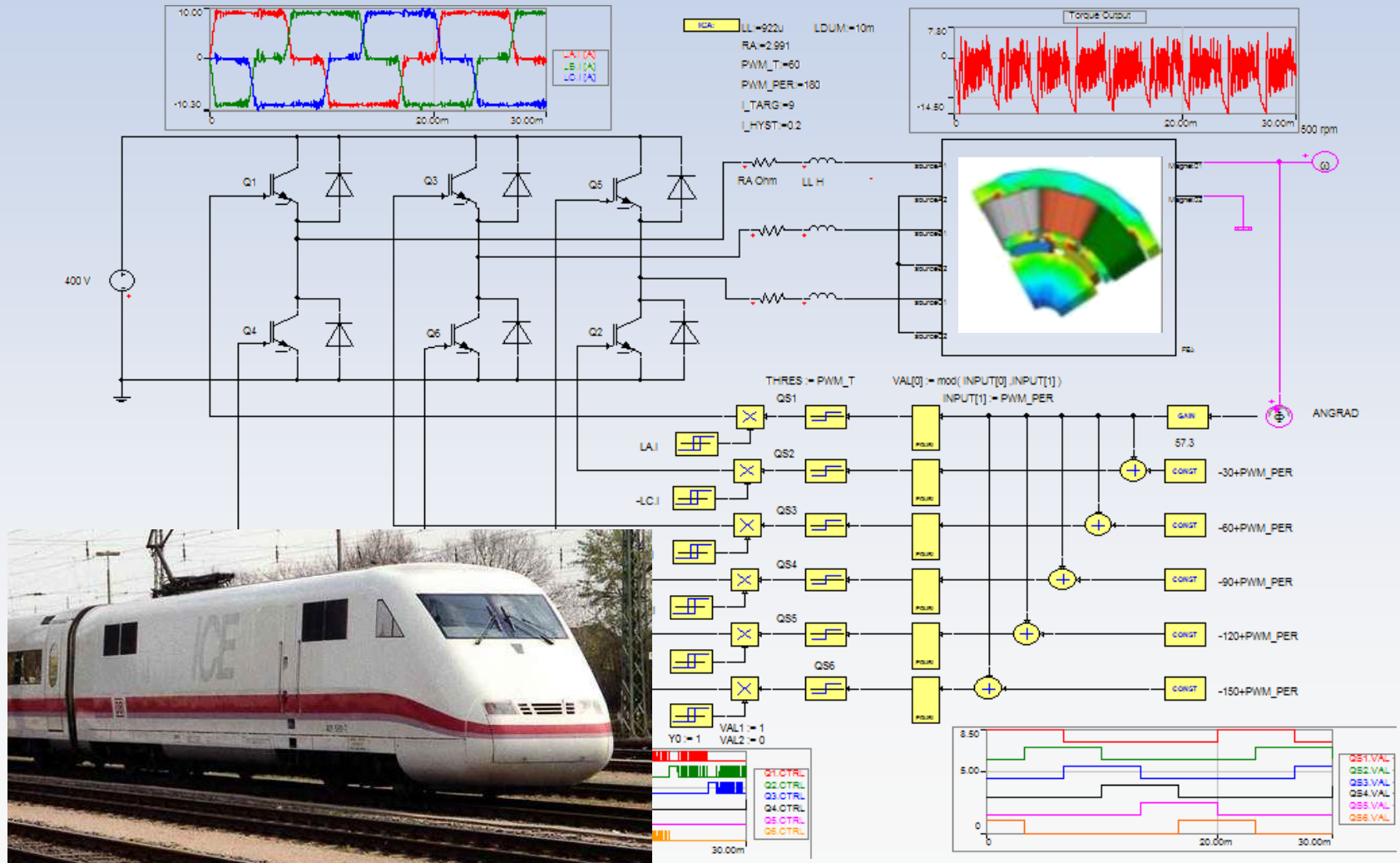

Variable Speed Drive EMC/EMI Issues



- **Classical Design Considerations:
Conducted low-frequency phenomena**

- Harmonic Line Currents
(16.7Hz-60Hz, $v \leq 49$)

Interaction of Converter
with Supply Network

- Interharmonics, Flicker

- Overvoltages

- Harmonic Motor Currents
(0 – 500Hz, $v \leq 49$)

Interaction of Converter
with Motor & Mechanics

- **Analysis of these Phenomena with Simulation
tools like Simplorer is “State of the Art”**

Variable-Speed Drive Developing EMI Issues

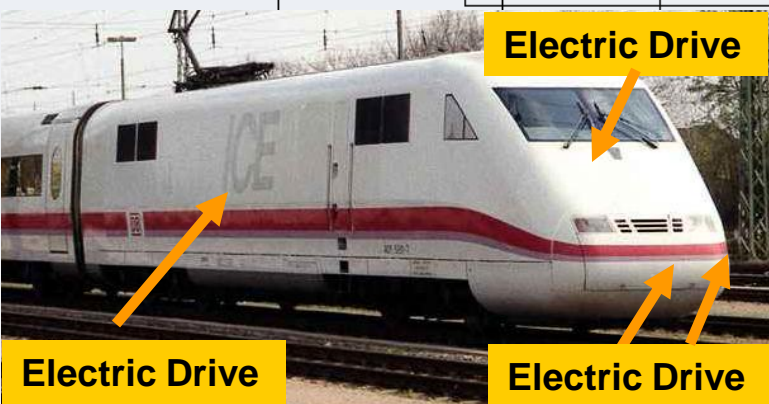
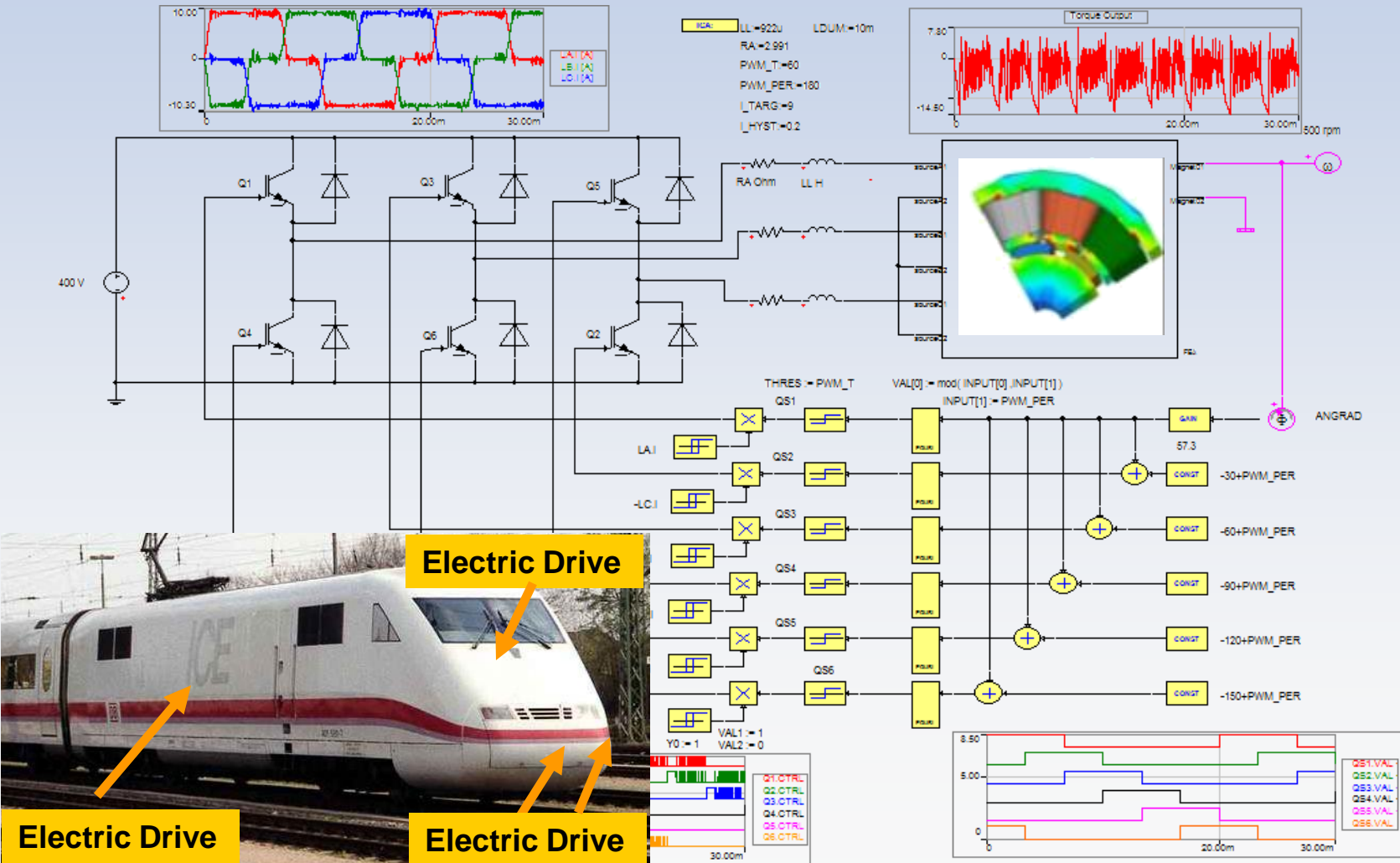

Variable Speed Drive EMC/EMI Issues



- **Developing Issues**

- Power electronics being installed closer to humans (e.g. ICE3 train or Hybrid car)
- Switching Frequencies are increasing
 - Higher Radiating Content
 - Frequency dependence of electrical parts becomes more relevant (e.g. skin effect)

- **Resulting Problems and Challenges**

- Bearing Currents (Common mode problem)
- Insulation Fatigue
- Losses / Thermal Problems
- Electromagnetic Field Limits

⇒ **Higher Requirement on Impedance
Characterisation of the system at higher frequencies**

⇒ **Require Simulation techniques not traditionally
applied in this area**

High Power Inverter Application



- These power converters are used in high speed trains (TGV)

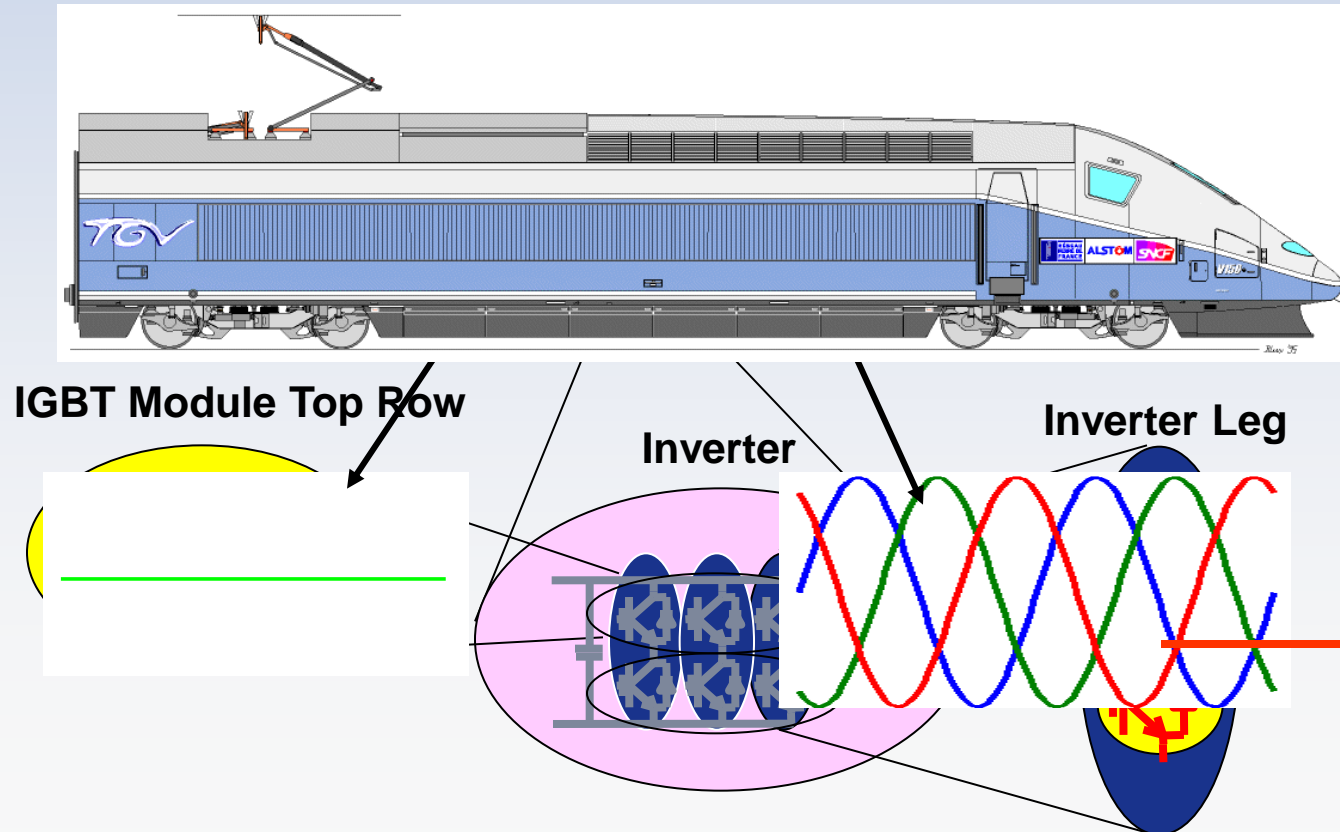

High Power Inverter Application

6.5kV IGBT Module Analysis

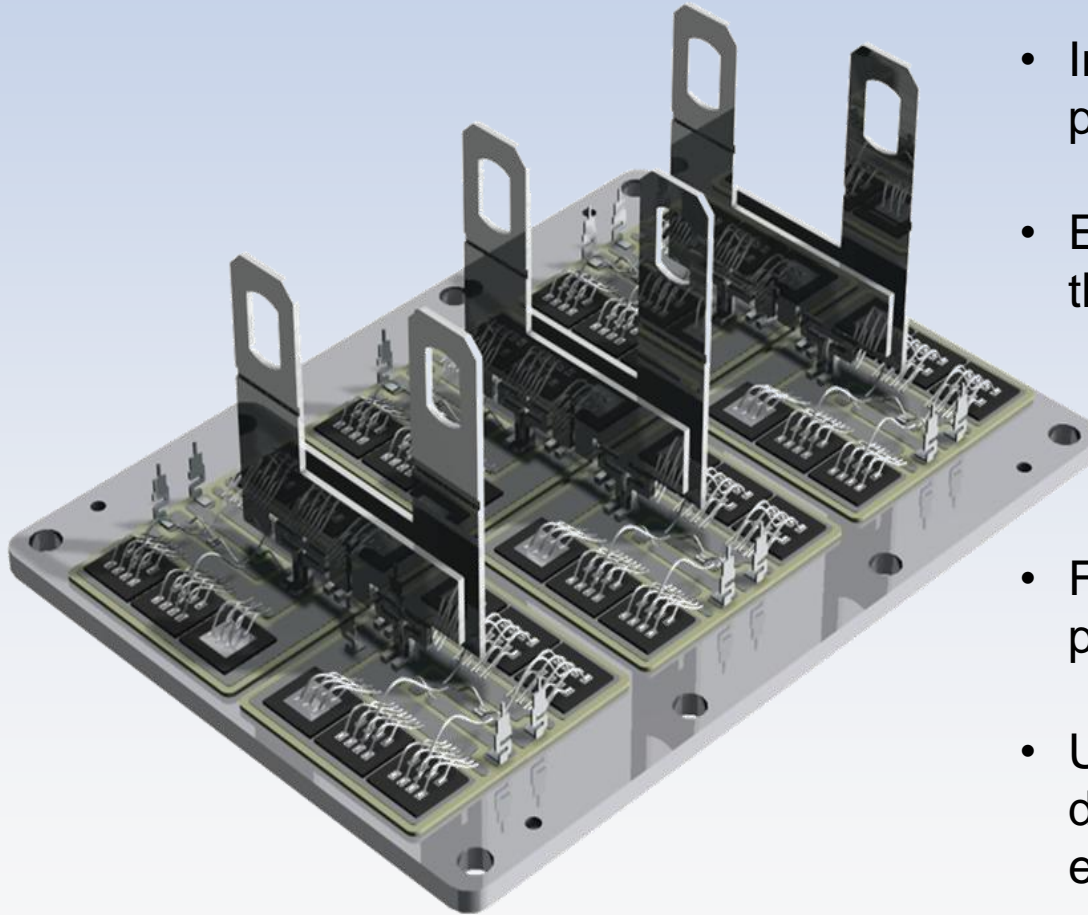

- Include package in IGBT performance
- Electrical Characterization of the IGBT
- Find switching currents for power dissipation
- Use power dissipation to determine environmental electromagnetic fields

High Power Inverter Application EMC Workflow

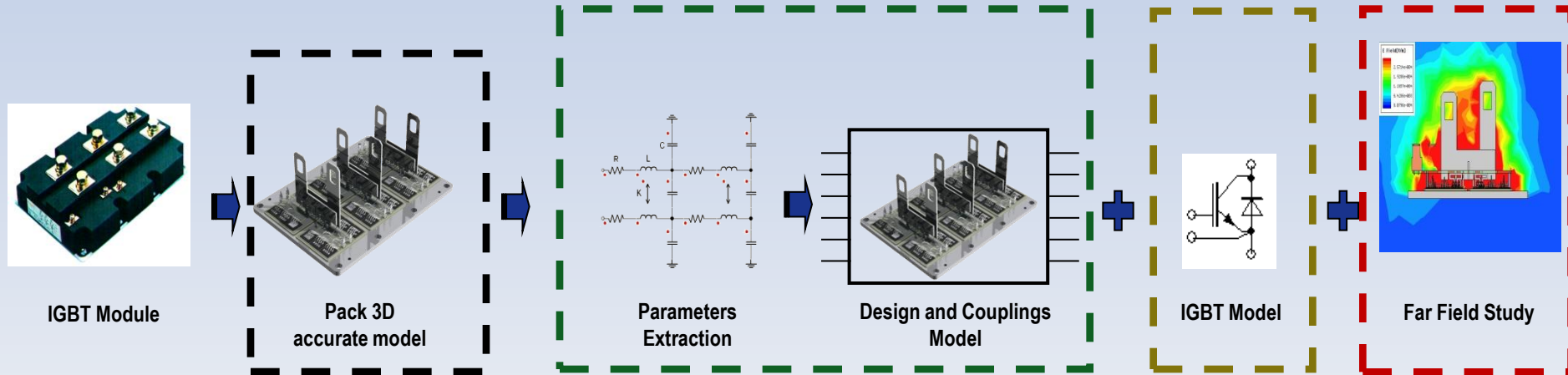

- Three-dimensional IGBT pack model
- Parasitic model extraction
- IGBT circuit model for System Simulation
- Far Field Study for Electric Field

High Power Inverter Application Simulation Techniques

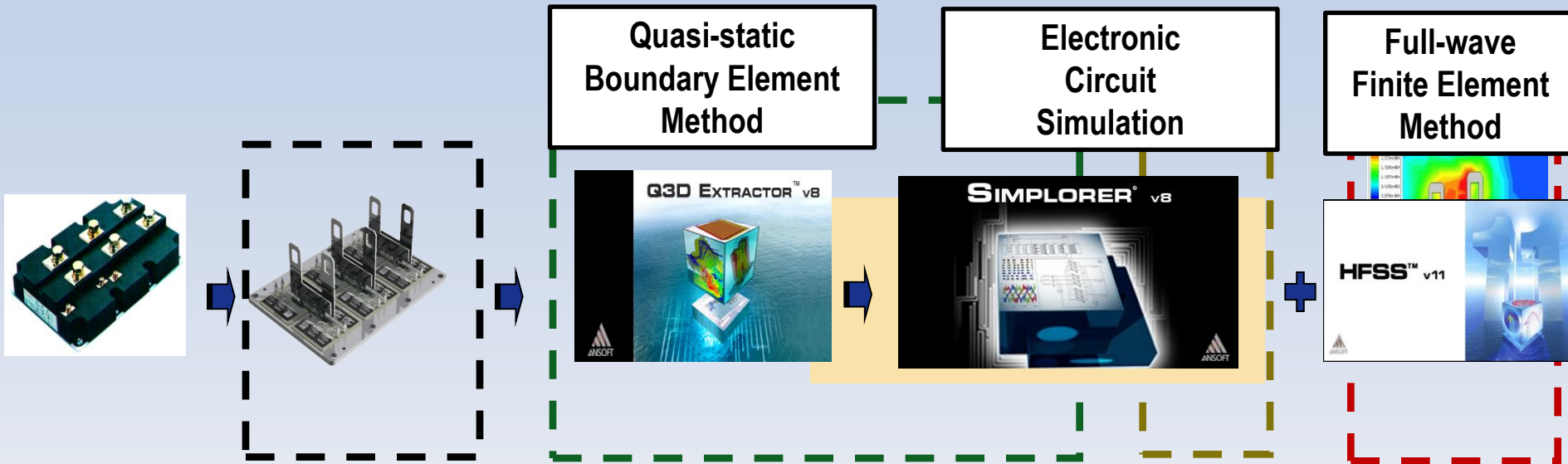

- Three-dimensional IGBT pack model
- Parasitic model extraction
- IGBT circuit model
- Far Field Study for Electric Field EM

EMI/EMC Electrical Parasitics Extraction

- Extract the resistance, inductance, capacitance and conductance (RLCG) parameters of the entire package

Frequency can have a significant impact on the design performance

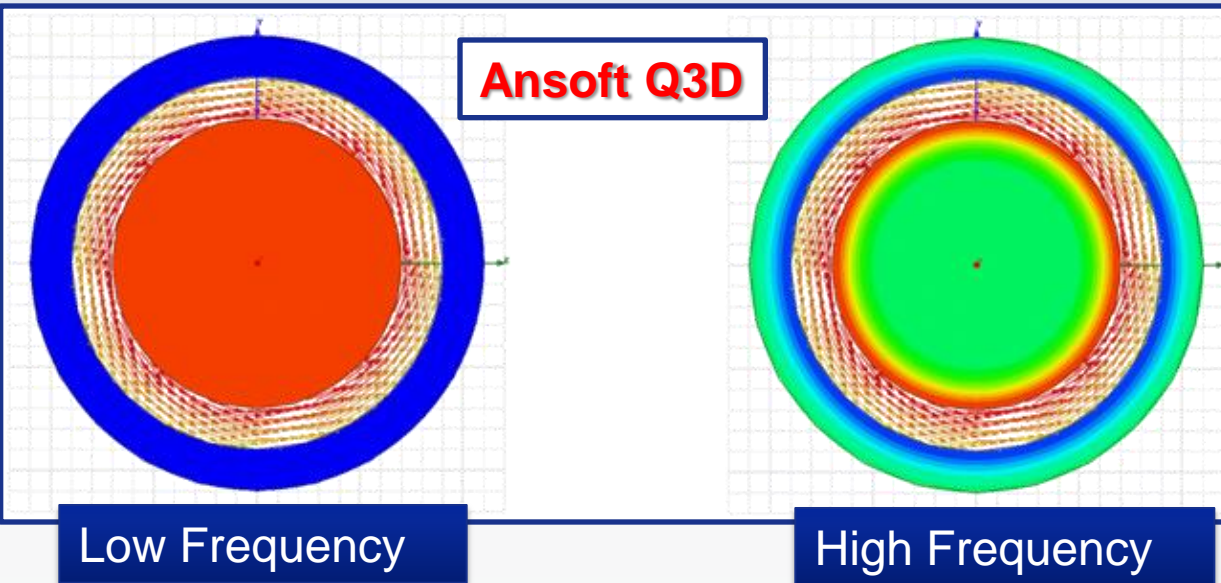
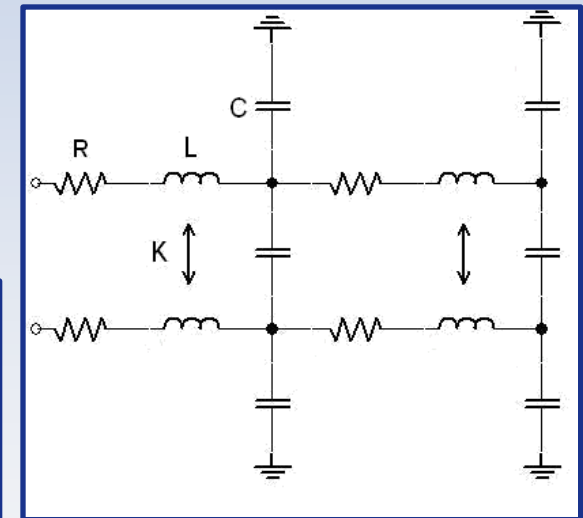

EMI/EMC

Electrical Parasitics Extraction



- Extracting parameters is straightforward as the nets are automatically assigned

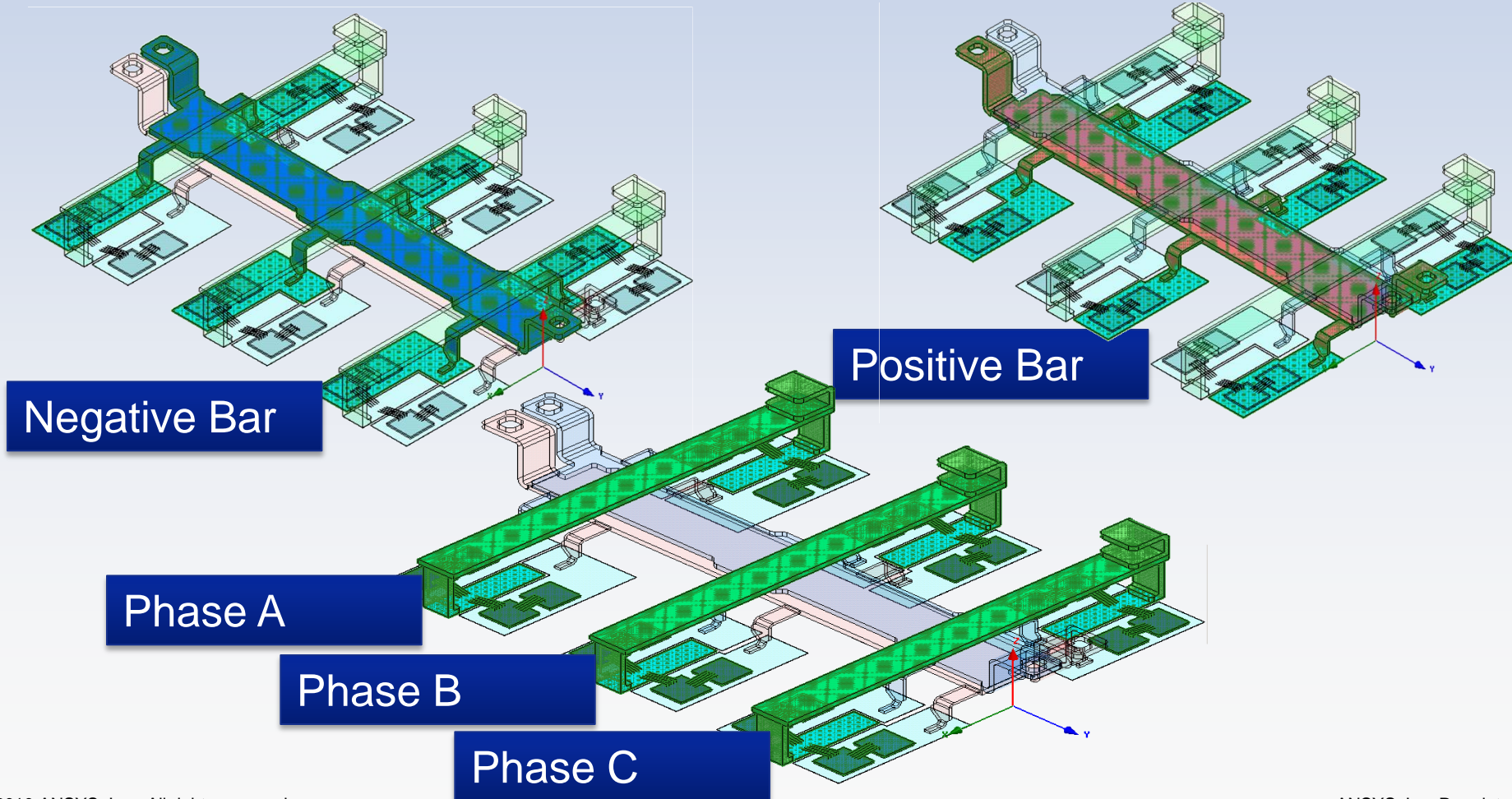

EMI/EMC

Q3D Example R-L Characterisation



- Inductance and Resistance are evaluated over frequency

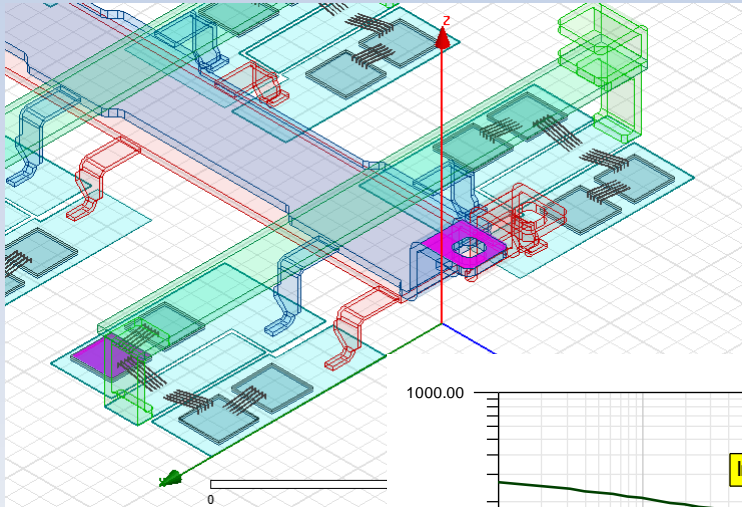

Positive Bus –
D2 to INPUT

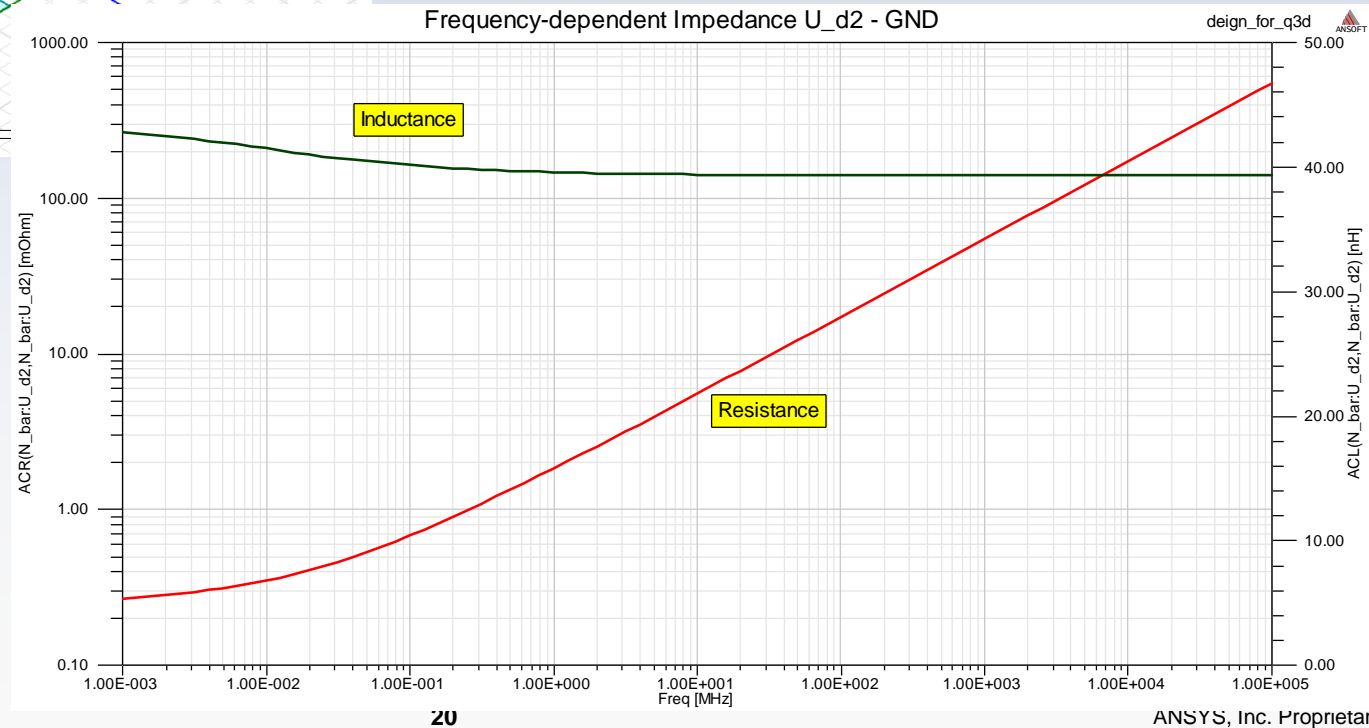

EMI/EMC Parasitics Extraction



- The simulation outputs consist of the RLC matrices, one for each frequency of interest.

The screenshot shows the ANSYS interface for parasitics extraction. The simulation setup is 'Setup1', 'Sweep1', and 'AC RL'. The 'Matrix' tab is active, and the frequency is set to '0 (MHz)'. The 'Resistance' and 'Inductance' options are checked. The units are 'ohm' for resistance and 'nH' for inductance. The 'Matrix' dropdown is set to 'Matrix', and the 'Export...' button is visible. The table below shows the extracted parasitics data for 0 MHz.

	collecteurpack:collecteur1a	collecteurpack:collecteur1b	collecteurpack:collecteur2a	collecteurpack:collecteur2b	collecteurpack:collecteur3a
Freq: 0 (MHz)					
collecteurpack:collecteur1a	0.00024714, 47.273	0.00010662, 38.024	0.00024714, 47.376	0.00010662, 37.924	0.00019129, 44.721
collecteurpack:collecteur1b	0.00010662, 38.024	0.00035739, 50.514	0.00010662, 38.057	0.00035739, 50.476	0.00010663, 41.674
collecteurpack:collecteur2a	0.00024714, 47.376	0.00010662, 38.057	0.00025298, 47.561	0.00010662, 37.955	0.00019129, 44.82
collecteurpack:collecteur2b	0.00010662, 37.924	0.00035739, 50.476	0.00010662, 37.955	0.00036322, 50.52	0.00010663, 41.57
collecteurpack:collecteur3a	0.00019129, 44.721	0.00010663, 41.674	0.00019129, 44.82	0.00010663, 41.57	0.00036871, 55.342
collecteurpack:collecteur3b	0.00010658, 38.665	0.00018615, 39.885	0.00010658, 38.694	0.00018615, 39.843	0.00010658, 37.826
collecteurpack:collecteur4a	0.00019129, 44.637	0.00010663, 41.644	0.00019129, 44.731	0.00010663, 41.543	0.00036287, 55.168
collecteurpack:collecteur4b	0.00010658, 38.79	0.00018615, 39.948	0.00010658, 38.822	0.00018615, 39.901	0.00010658, 37.951
collecteurpack:d1a	0.00024131, 47.067	0.00010662, 37.984	0.00024131, 47.157	0.00010662, 37.886	0.00019129, 44.591
collecteurpack:d1b	0.00010662, 38.143	0.00035155, 50.485	0.00010662, 38.18	0.00035155, 50.434	0.00010663, 41.799
collecteurpack:d2a	0.00019129, 44.534	0.00010663, 41.611	0.00019129, 44.623	0.00010663, 41.514	0.00035703, 54.972
collecteurpack:d2b	0.00010658, 38.956	0.00018615, 40.026	0.00010658, 38.992	0.00018615, 39.974	0.00010658, 38.118
emetteurpack:dio1a	0, 12.452	0, 9.791	0, 12.401	0, 9.8142	0, 9.099
emetteurpack:dio1b	0, 5.5942	0, 14.206	0, 5.4701	0, 14.299	0, 7.805
emetteurpack:dio2a	0, 11.151	0, 13.035	0, 11.11	0, 13.059	0, 15.496
emetteurpack:dio2b	0, 6.5151	0, 8.0262	0, 6.3914	0, 8.1293	0, 4.6768
emetteurpack:emetteur1a					

EMI/EMC IGBT Mesh and Field Result

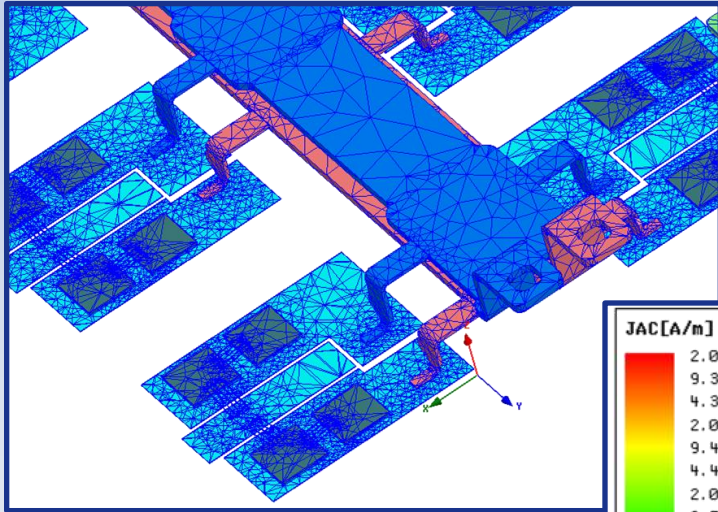

Current Distribution

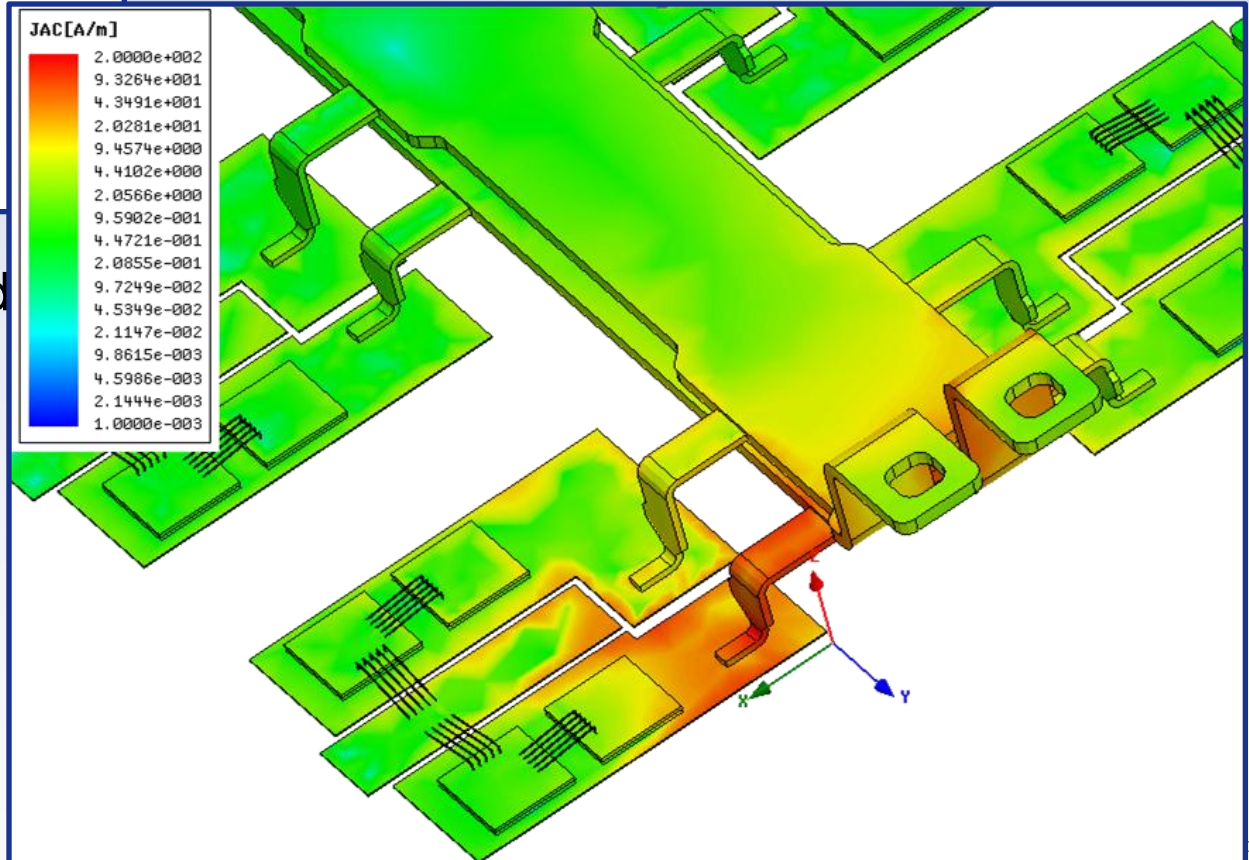

The structure is meshed using automatic and adaptive meshing

Pass	Type	# Triangle	DeltaR	DeltaL
1	C	11558	N/A	N/A
2	C	15269	4.2826	N/A
3	M	20267	2.6867	N/A
4	M	27011	2.5257	6.1143
5	M	35472	0.36587	2.0524

EMI/EMC Parasitics Extraction



- **How do we set up the frequency sweep?**

- Nyquist sampling: To capture a time step of T_s , obtain frequency domain information up to:

$$F_{\max} = \frac{1}{2 \times t_s}$$

- For a time domain waveform with a risetime of 80 ns, in order to capture the ringing in the time domain, we would want to capture at least 4 samples during this risetime. This implies a sampling time of 20 ns

- **We need to solve up to 50 MHz (= 1/20ns)**

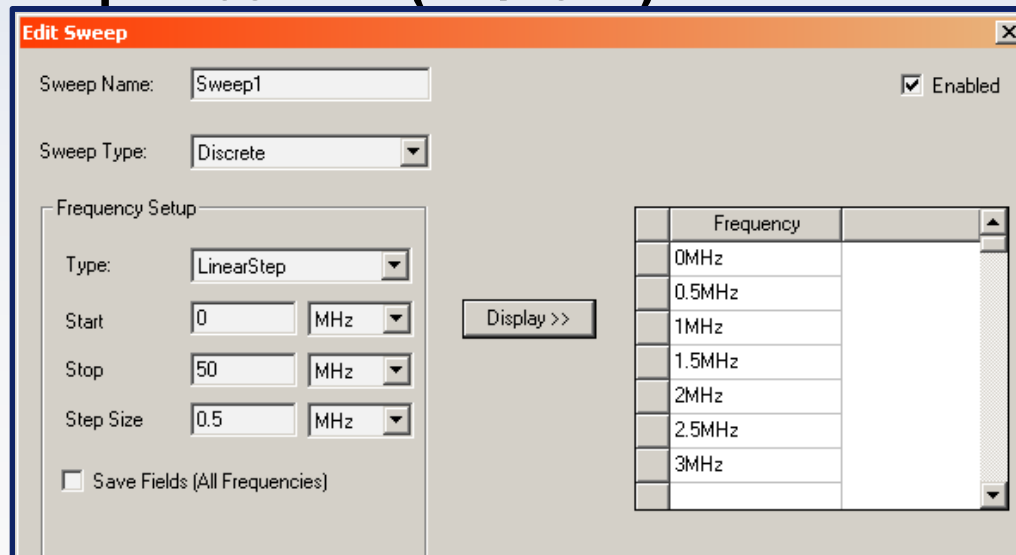

IGBT Characterization



Technische Information / Technical Information		eupec	
IGBT-Module IGBT-Modules		FZ 600 R 65 KF1	
Charakteristische Werte / Characteristic values			
Transistor / Transistor			
Einschaltverzögerungszeit (ind. Last) turn on delay time (inductive load)	$I_C = 600A, V_{CE} = 3600V$	t_{on}	
	$V_{GE} = \pm 15V, R_{\theta(jc)} = 4.3K, C_{GE} = 88nF, T_{vj} = 25^{\circ}C,$		- 0,75 - μs
	$V_{GE} = \pm 15V, R_{\theta(jc)} = 4.3K, C_{GE} = 88nF, T_{vj} = 125^{\circ}C,$		- 0,72 - μs
Anstiegszeit (induktive Last) rise time (inductive load)	$I_C = 600A, V_{CE} = 3600V$	t_r	
	$V_{GE} = \pm 15V, R_{\theta(jc)} = 4.3K, C_{GE} = 88nF, T_{vj} = 25^{\circ}C,$		- 0,37 - μs
	$V_{GE} = \pm 15V, R_{\theta(jc)} = 4.3K, C_{GE} = 88nF, T_{vj} = 125^{\circ}C,$		- 0,40 - μs

Nominal Working Point Values [2/13]

Vce nom	3600	Nominal Collector-Emitter Blocking Voltage [V]
Ic nom	600	Nominal Collector Current [A]
Tj nom	125	Nominal Reference Temperature [°C]
Vge on	15	On-Switch Gate-Emitter (Drive) Voltage [V]
Vge off	-15	Off-Switch Gate-Emitter (Drive) Voltage [V]

Buttons: Import Model..., Save Model..., < Back, Next >, Cancel

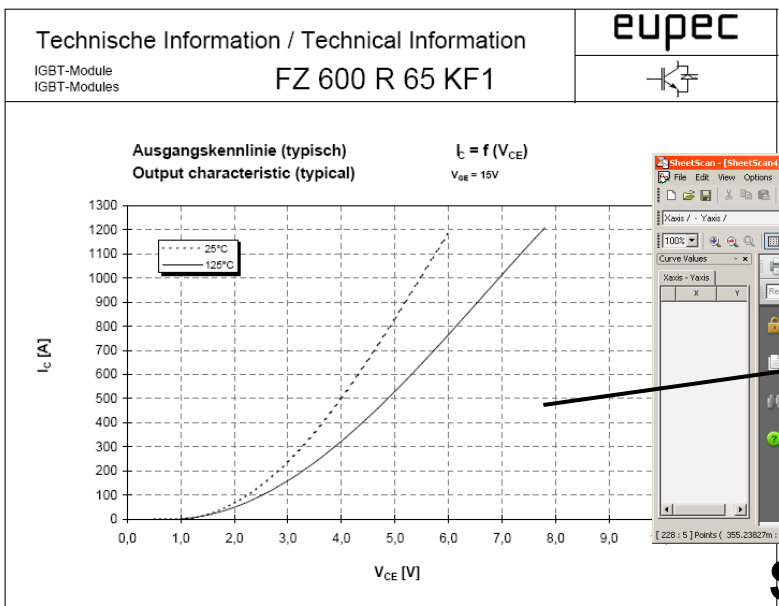

SheetScan - [SheetScan]

File Edit View Options Picture Coordinate System Curve Window Help

Curve Values

X-axis - Y-axis

Rechercher

Technische Information / Technical Information
FZ 600 R 65 KF1

Ausgangskennlinie (typisch)
Output characteristic (typical)

[228 / 5] Points (395,23827m ; 2,387577)

Transfer Characteristic $I_C = f(V_{GE})$ [5/13]

Ch.01 - 125.0°C | Ch.02 - 25.0°C

Vge [V]	Ic [A]	Enable
9.003...	28...	<input checked="" type="checkbox"/>
9.170...	34...	<input checked="" type="checkbox"/>
9.348...	39...	<input checked="" type="checkbox"/>
9.521...	52...	<input checked="" type="checkbox"/>
9.696...	70...	<input checked="" type="checkbox"/>
9.869...	94...	<input checked="" type="checkbox"/>
9.159...	120...	<input checked="" type="checkbox"/>
9.288...	149...	<input checked="" type="checkbox"/>
9.583...	183...	<input checked="" type="checkbox"/>
9.767...	222...	<input checked="" type="checkbox"/>
9.780...	266...	<input checked="" type="checkbox"/>
10.23...	324...	<input checked="" type="checkbox"/>
10.44...	376...	<input checked="" type="checkbox"/>
10.66...	436...	<input checked="" type="checkbox"/>
10.89...	499...	<input checked="" type="checkbox"/>
11.12...	562...	<input checked="" type="checkbox"/>

Boundary Conditions

Temp: 125

Vce: 10

Fitting Ranges

Ic min: 28.77

Ic max: 1232

Fitting Characteristic Order

Ch.01 - 125.0°C

Ch.02 - 25.0°C

Buttons: Import Model..., Save Model..., < Back, Next >, Cancel

SheetScan

IGBT Device Generation Characterization Tool



Extraction of the IGBT Electro-Thermal Parameters

Transfer characteristic curve from datasheet

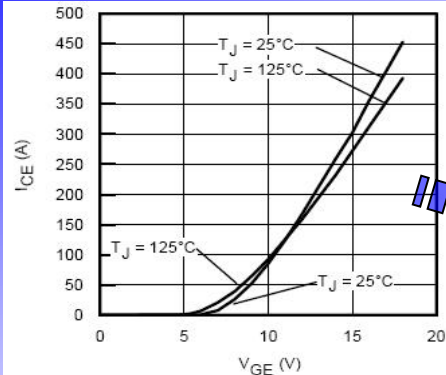
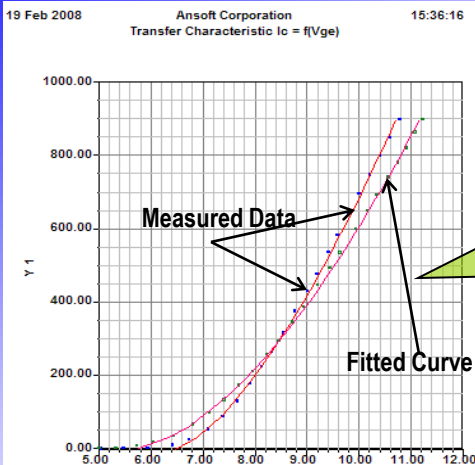

Fig. 12 - Typ. Transfer Characteristics
 $V_{CE} = 50V$; $t_p = 10\mu s$

Fitted curve vs. measured data



Transfer Characteristic $I_c = f(V_{ge})$ [5/13]

File Help

Ch.01 - 25.0°C Ch.02 - 125.0°C

Vge [V]	Ic [A]	Enable
5.052...	2.73...	<input checked="" type="checkbox"/>
5.474...	4.02...	<input checked="" type="checkbox"/>
5.940...	5.30...	<input checked="" type="checkbox"/>
6.424...	13.4...	<input checked="" type="checkbox"/>
6.741...	27.0...	<input checked="" type="checkbox"/>
7.101...	55.8...	<input checked="" type="checkbox"/>
7.383...	91.4...	<input checked="" type="checkbox"/>
7.664...	132....	<input checked="" type="checkbox"/>
7.910...	179....	<input checked="" type="checkbox"/>
8.139...	227....	<input checked="" type="checkbox"/>
8.324...	266....	<input checked="" type="checkbox"/>

Boundary Conditions
 Temp: 25 Temperature
 Vce: 20 Const. Collector-Emitter Voltage

Fitting Ranges
 Ic min: 2.73 Minimum Current
 Ic max: 897.5 Maximum Current

Fitting Characteristic Order
 Ch.02 - 125.0°C Nominal
 Ch.01 - 25.0°C Different

Fitting
 Validate Show Result Show Log Options

< Back Next > Cancel

```
// Update IGBT Model Parameters
Up = 5.51895
K = 5.88228
n_fet = 1.70371
alpha_Up = -0.507243
alpha_K = -2.57592
alpha_nfet = 0.0011548
```

Extracted parameter values

IGBT Family Electro-Thermal Model



Average IGBT Model

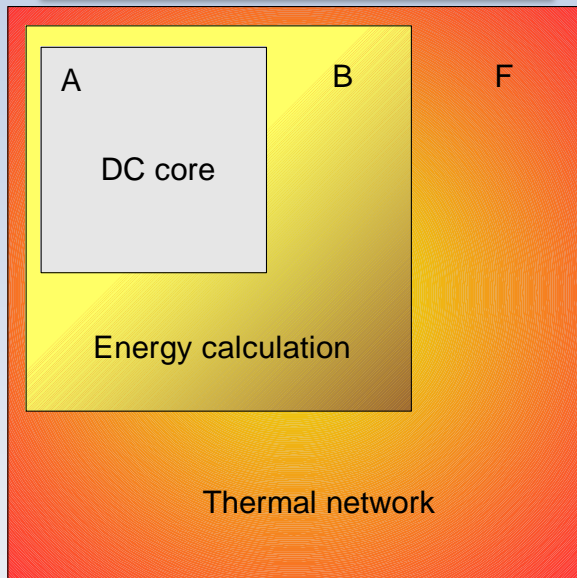

Maximum simulation speed:

- Accurate static behaviour
- Accurate thermal response
- No voltage and current transients
- Suitable for system design analysis

Dynamic IGBT Model

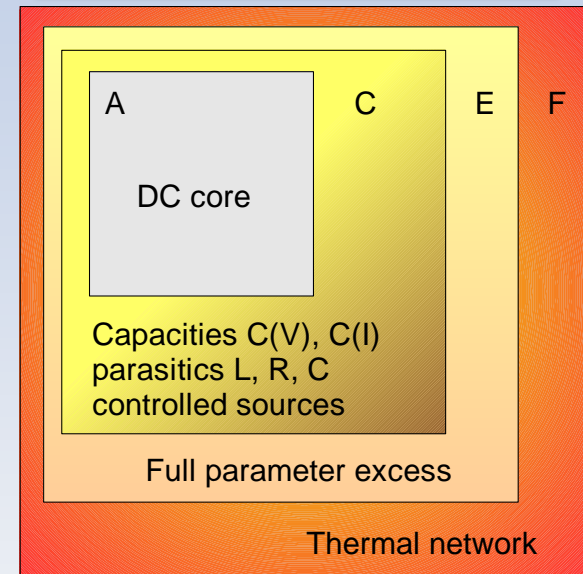

Maximum simulation accuracy:

- Sophisticated semiconductor based model
- Accurate static, dynamic and thermal behaviour
- Accurate gate voltage and current waveforms
- Suitable for drive optimization, EMI/EMC

The Dynamic IGBT Model

- Dynamic IGBT shares the same static the Average model
- The switching energy of the Dynamic IGBT model is the direct integration of the switching voltage and current

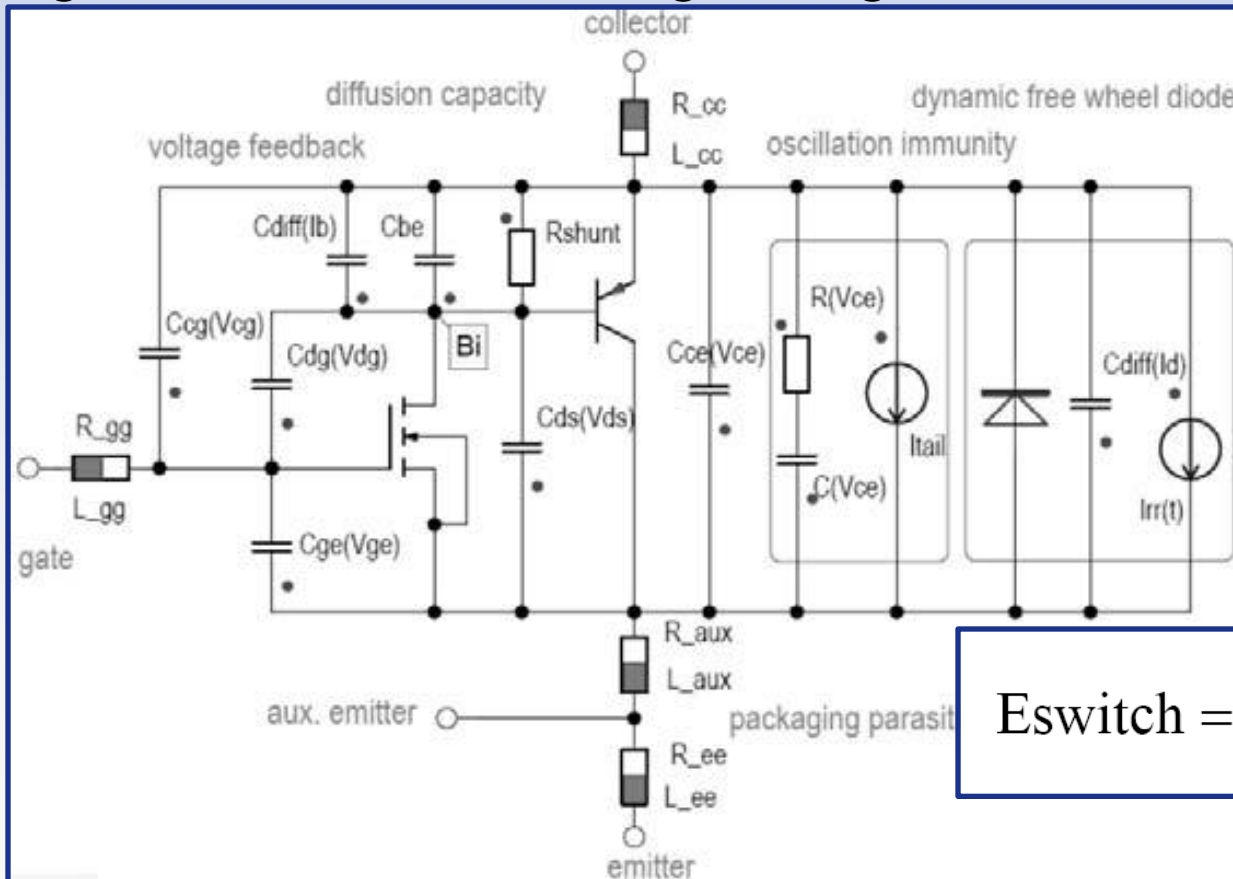

$$E_{switch} = \int_{t_{start}}^{t_{stop}} V_{ce}(t) \cdot I_c(t) dt$$

The Dynamic IGBT Model (2)

- Dynamic IGBT accurately captures the switching waveforms
- Suitable for EMI/EMC analysis

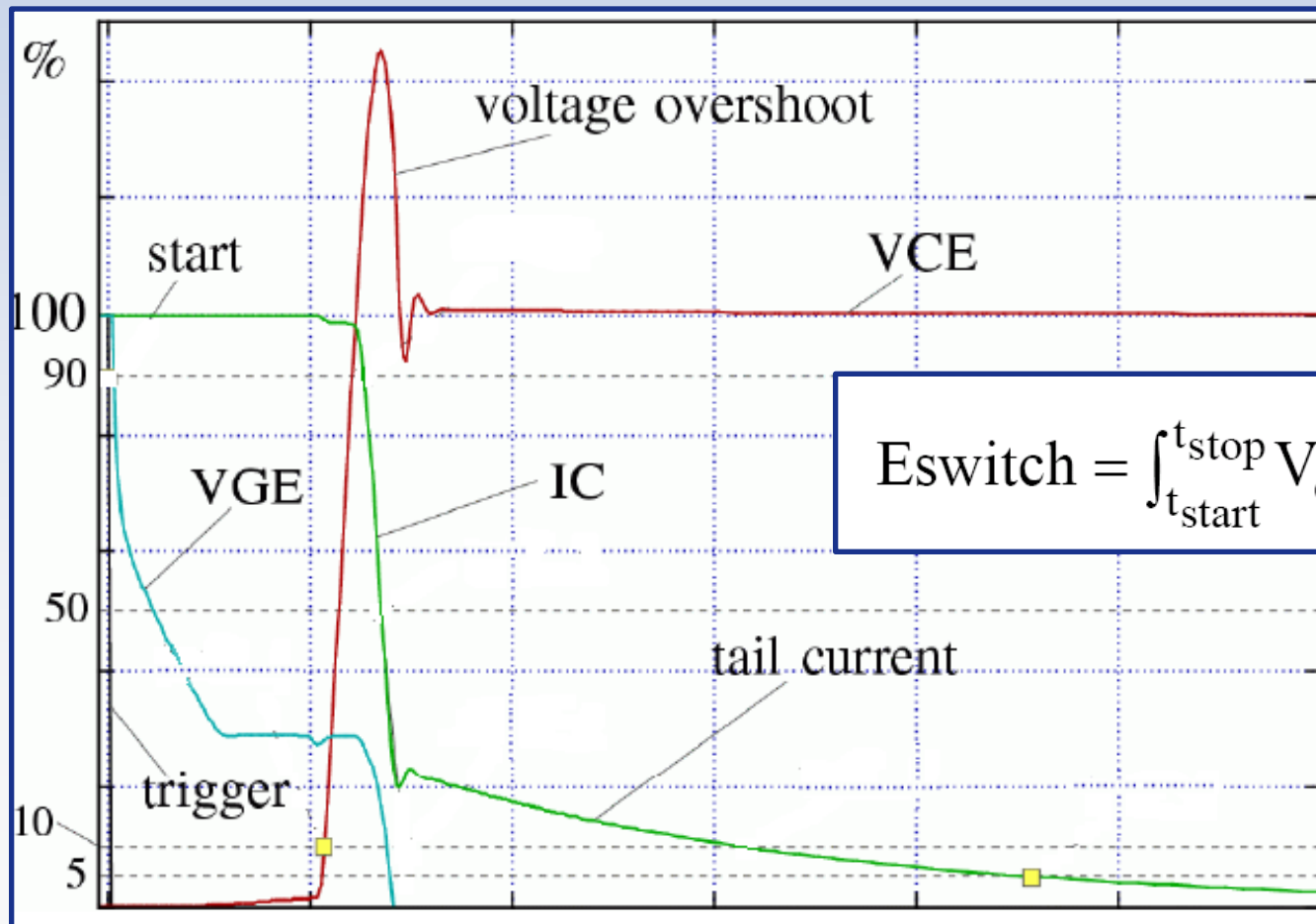

Circuit Design based on Parametrized IGBT and Frequency Dependent Model

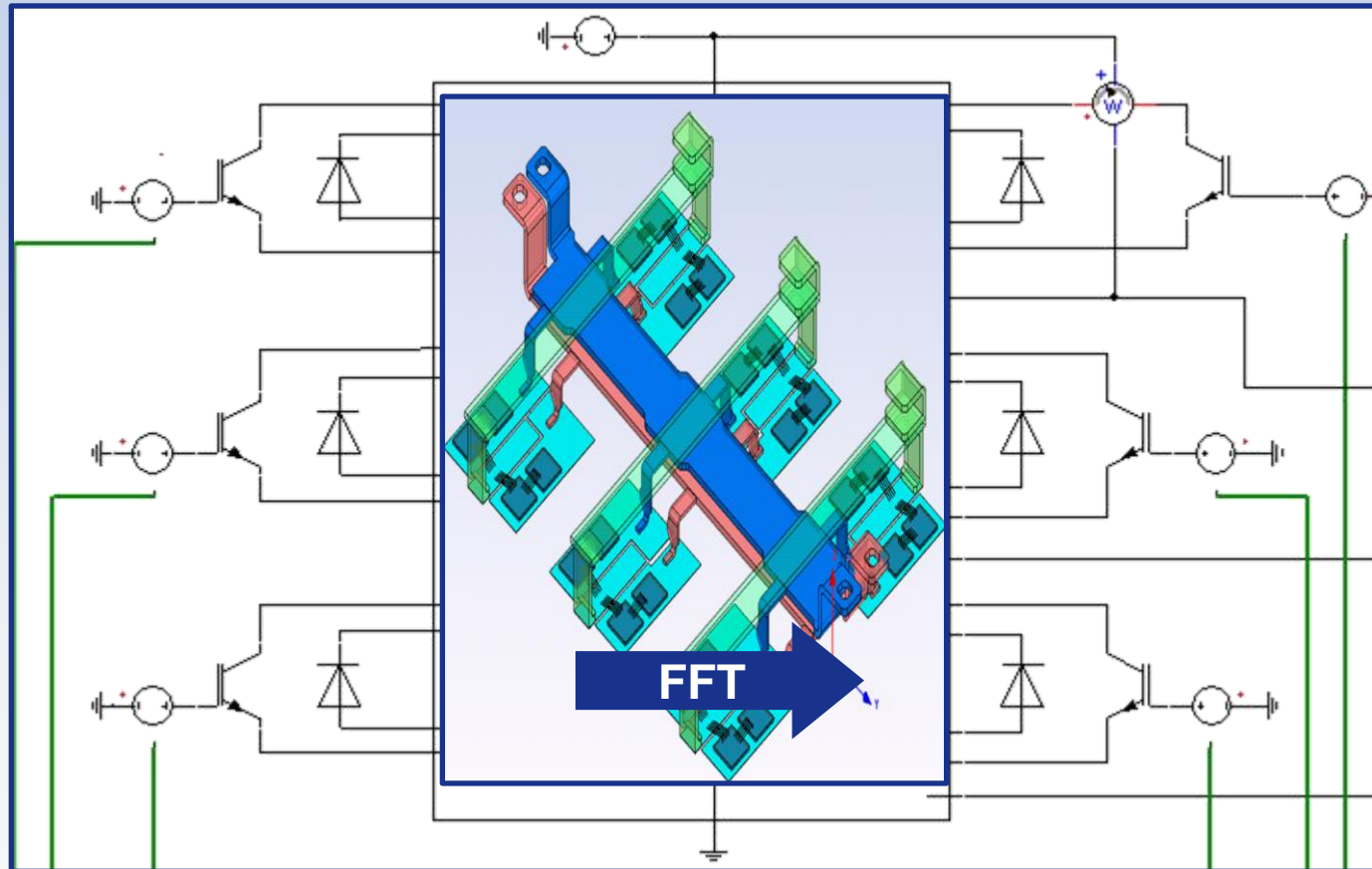

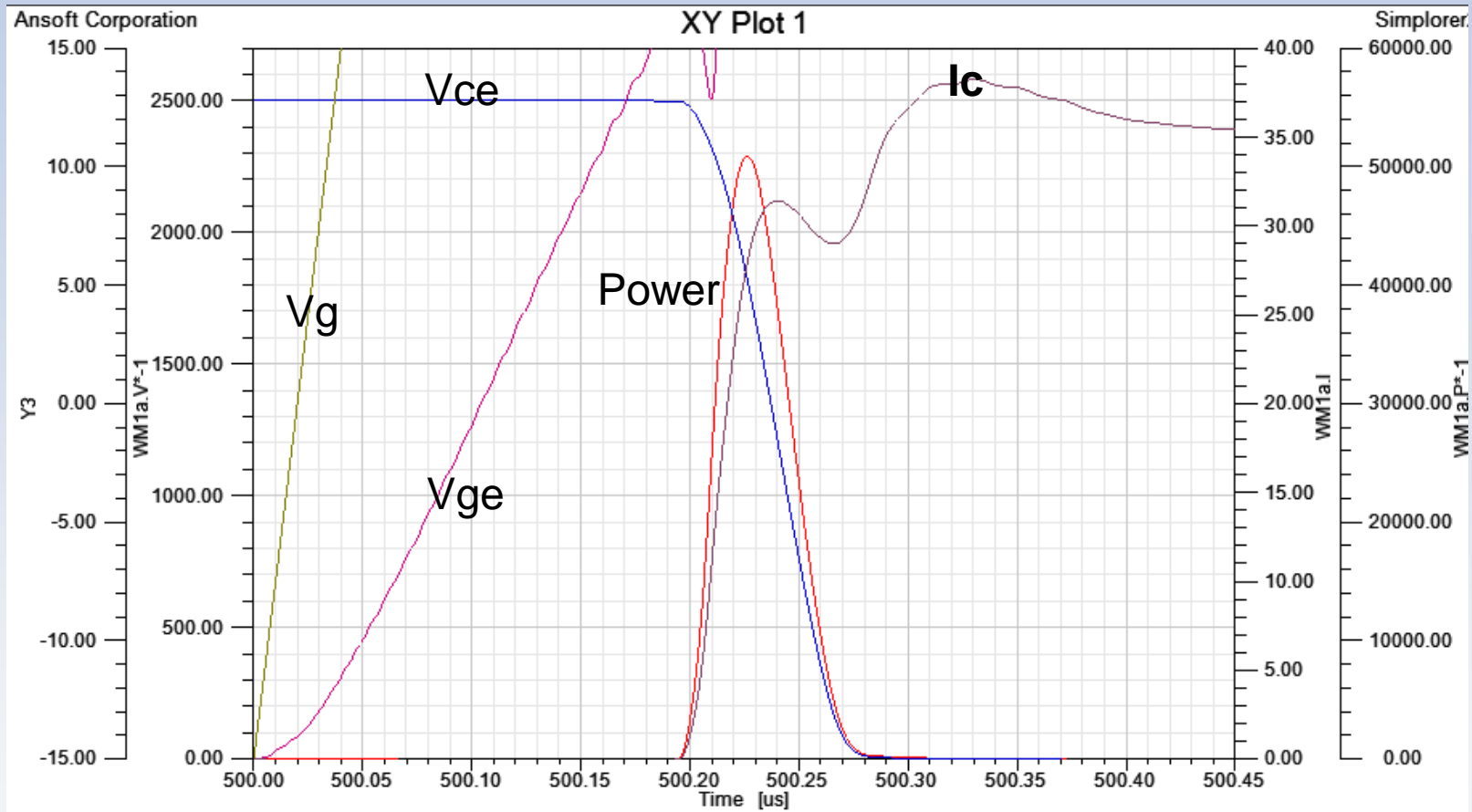

The power pulse duration is much smaller than the rise/fall time of Ic and Vce

Circuit Design based on Parametrized IGBT and Frequency Dependent Model

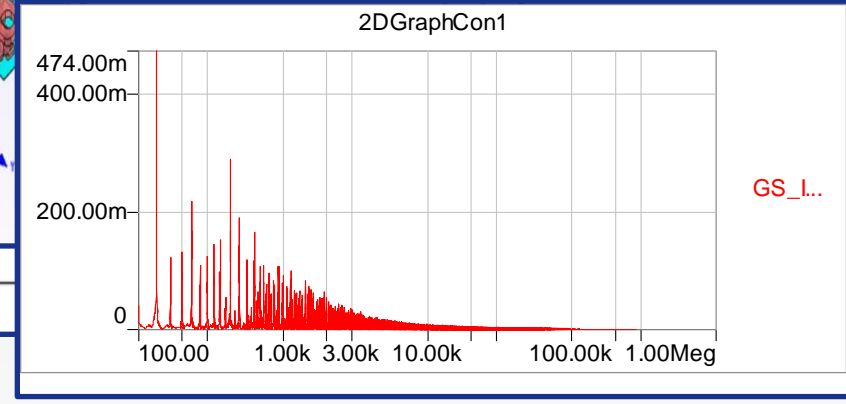
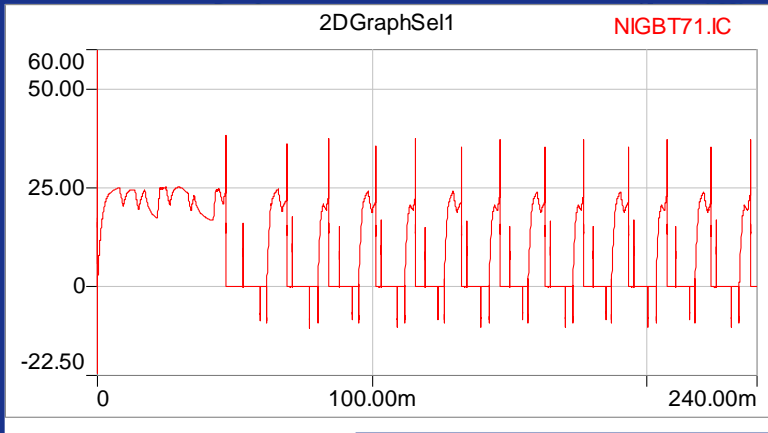
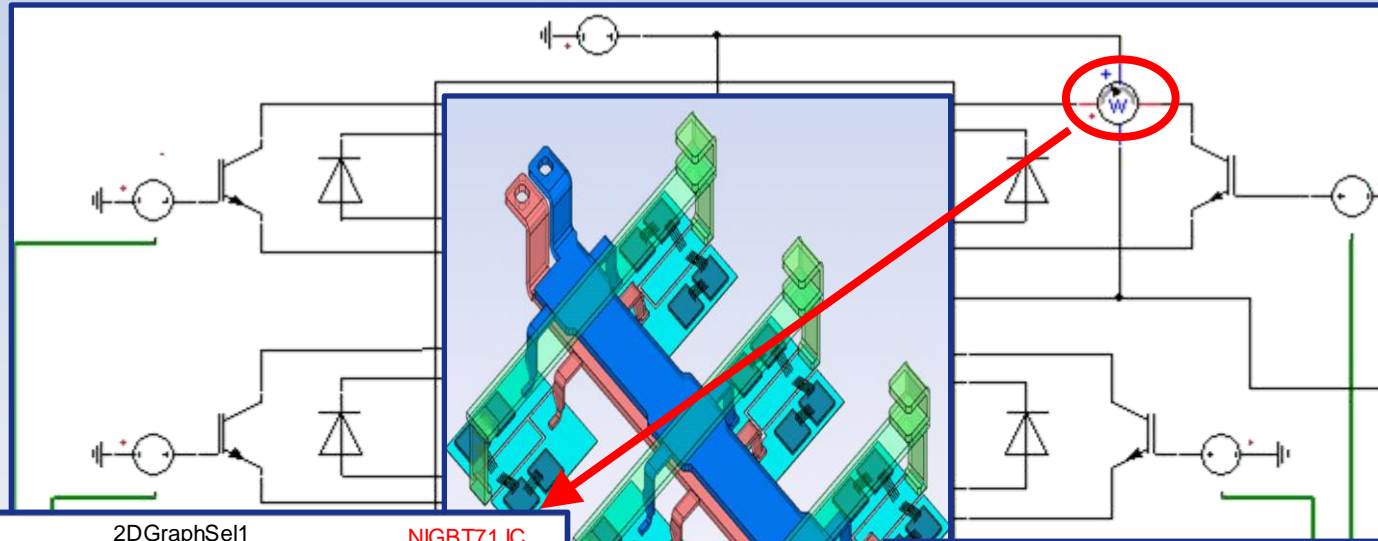

Extract Power Loss

Full Wave Effect

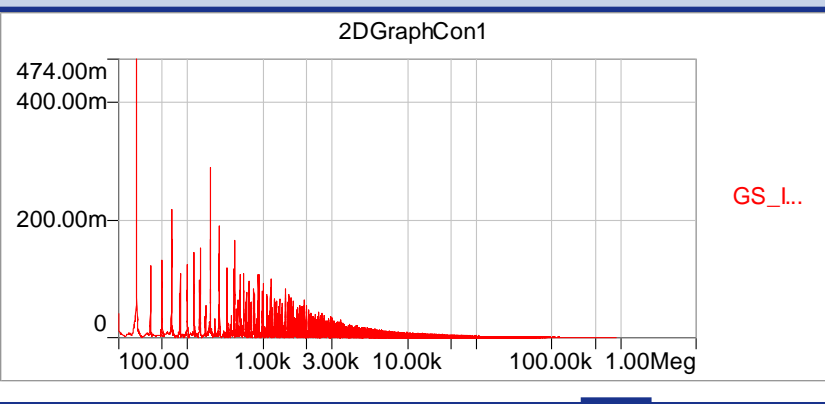

Ansoft HFSS

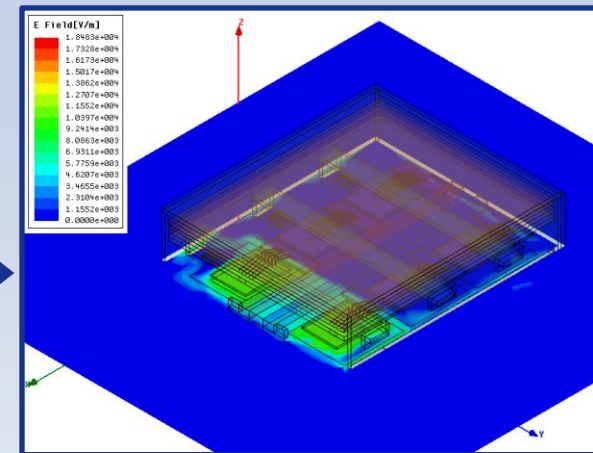

Multiplied magE plots by Simplorer

Emission Test

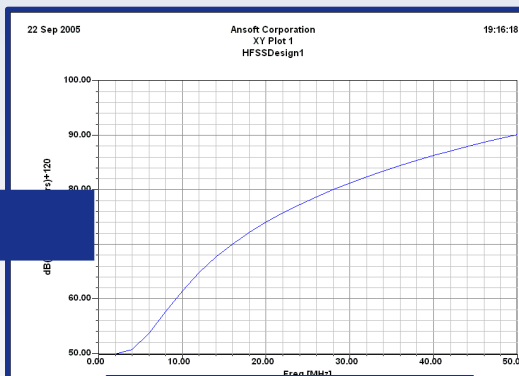
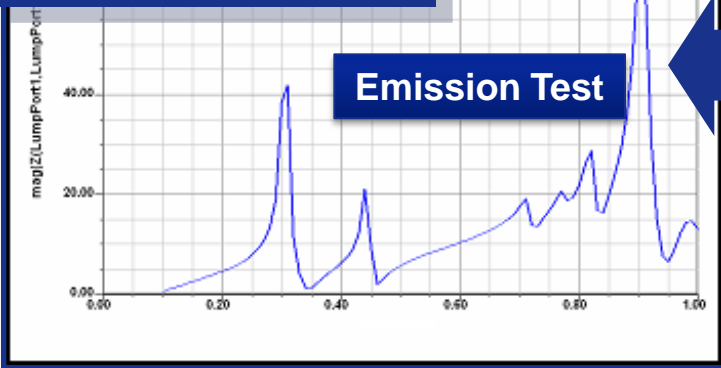

MagE@10m by specified inputs

Freq. res.

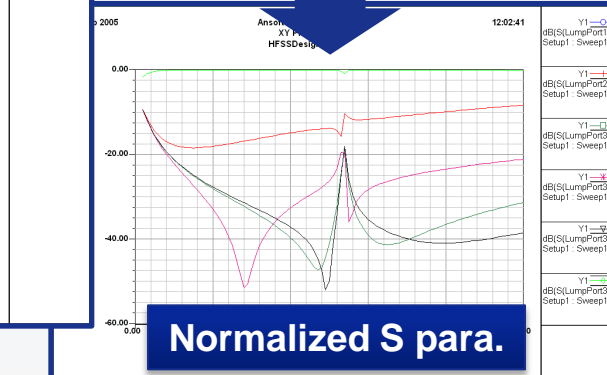

Normalized S para.

Emitted Fields



For each frequency, the power amplitude is entered

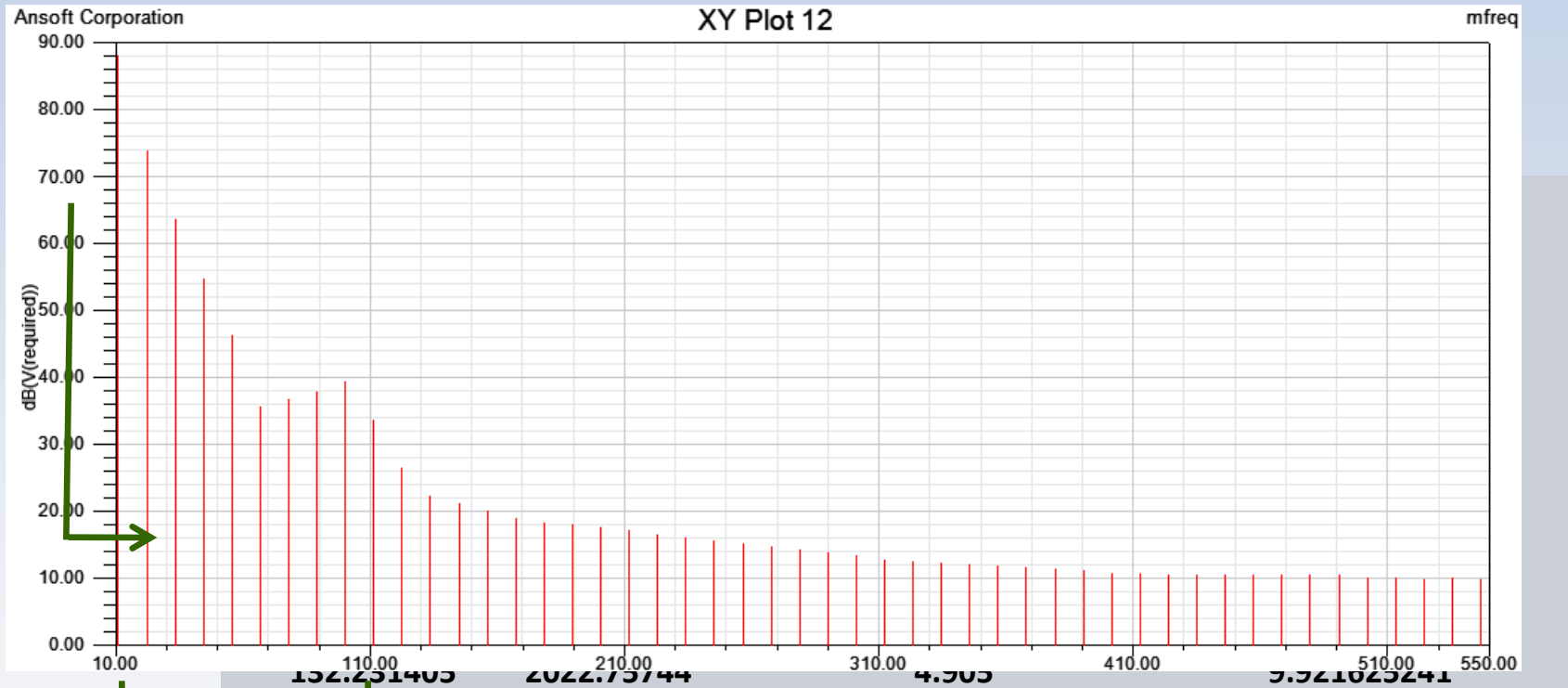

Spectrum from Simplorer

Outputs from Simplorer
Inputs for HFSS

Outputs From HFSS
(normalized results)

Fields Levels

Emitted Fields



Frequency range	Electric field strength, E (V/m)	Magnetic field strength, H (A/m)	Magnetic flux density, B (μT)	Equivalent plane wave power density, S_{eq} (W/m ²)	Contact current, I_c (mA)	Limb induced current, I_L (mA)
0 — 1Hz	—	1,63x10 ⁵	2x10 ⁵	—	1,0	—
1 — 8 Hz	20 000	1,63x10 ⁵ /f ²	2x10 ⁵ /f ²	—	1,0	—
8 — 25 Hz	20 000	2x10 ⁴ /f	2,5x10 ⁴ /f	—	1,0	—
0,025 — 0,82kHz	500/f	20/f	25/f	—	1,0	—
0,82 — 2,5 kHz	610	24,4	30,7	—	1,0	—
2,5 — 65 kHz	610	24,4	30,7	—	0,4 f	—
65 — 100 kHz	610	1 600/f	2 000/f	—	0,4 f	—
0,1 — 1 MHz	610	1,6/f	2/f	—	40	—
1 — 10 MHz	610/f	1,6/f	2/f	—	40	—
10 — 110 MHz	61	0,16	0,2	10	40	100
110 — 400 MHz	61	0,16	0,2	10	—	—
400 — 2 000 MHz	3f ²	0,008f ²	0,01f ²	f/40	—	—
2 — 300 GHz	137	0,36	0,45	50	—	—

- Regulators impose maximum levels of electric fields close to electric equipment.
- In the 10-110 MHz range:

$$E_{max}=61V/m$$

Exposure limits defined by European Community

Emitted Fields

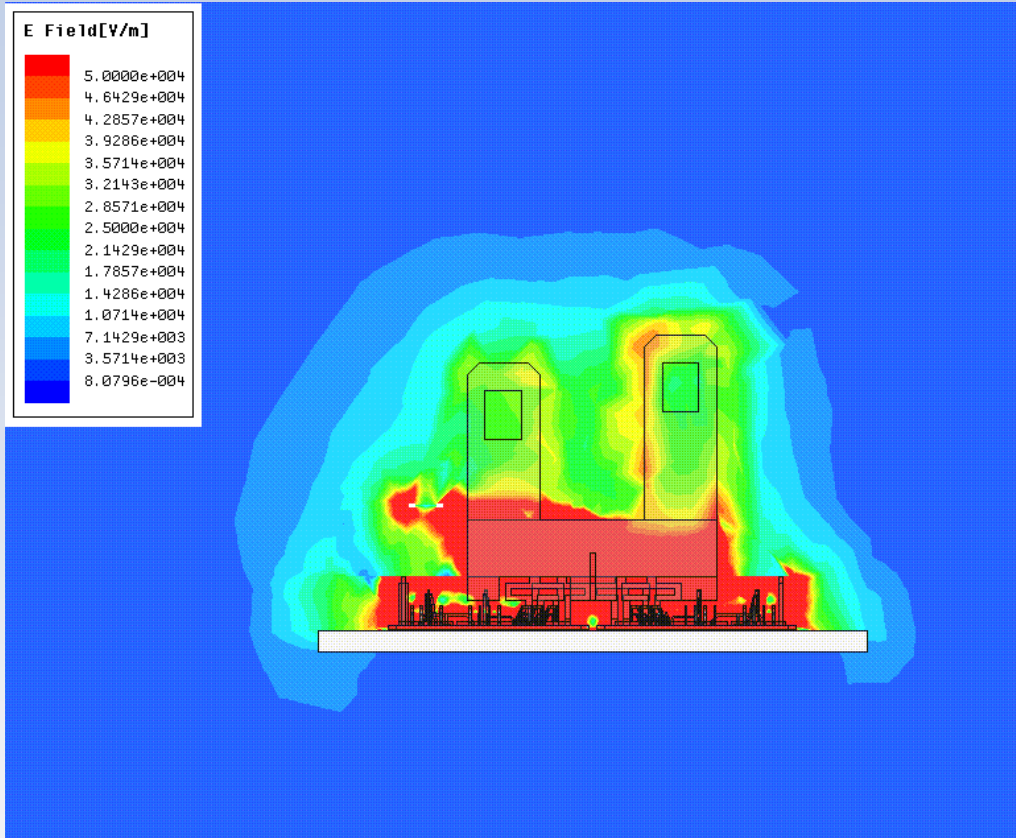

mag E @ 100 MHz, Power = 10 000W

- The E field is very localized close to the module even at 100 MHz
- However, the very high power can lead to large values of E field even far from the module
- This design is fine at 110MHz.

Spectrum (MHz)	Power (W)	E field at 1m (V/m)
115.7024793	2308.359536	10.35553171

The virtual test of the whole car body

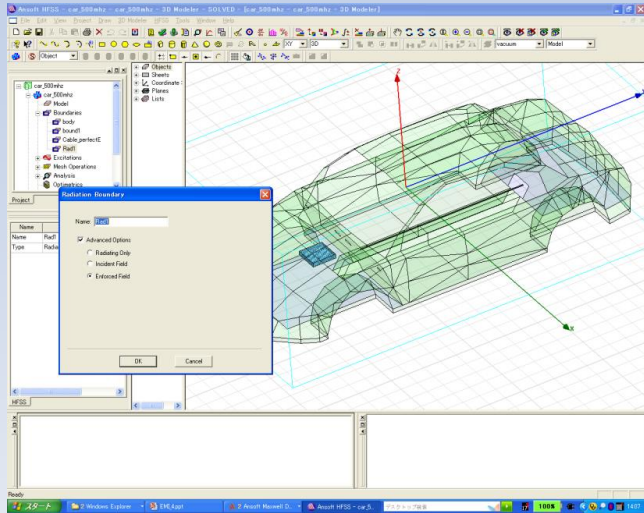

Setting the IGBT package

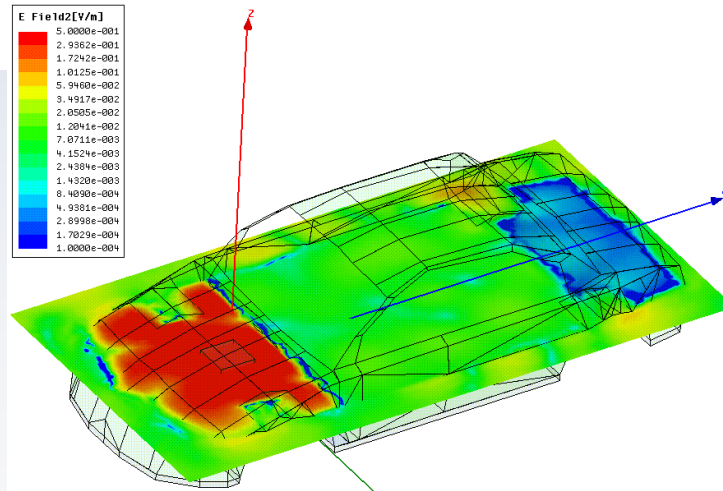
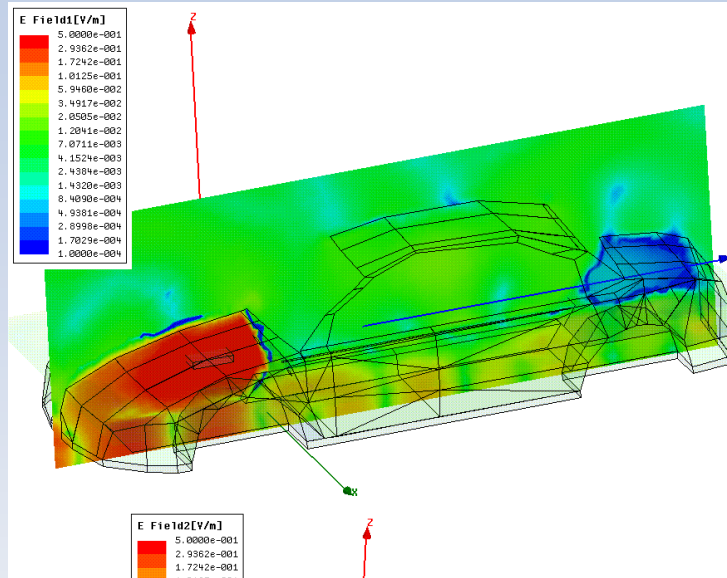

Mesh: 187,137

CPU time: 14m6s (Pentium M, 2GHz)

Noise transfer between an IGBT package and a cable

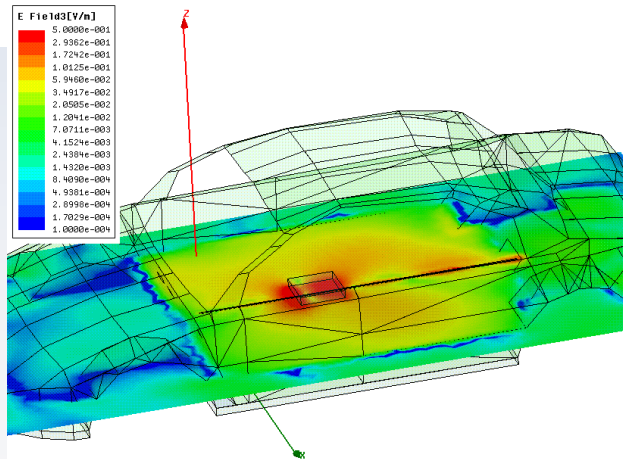
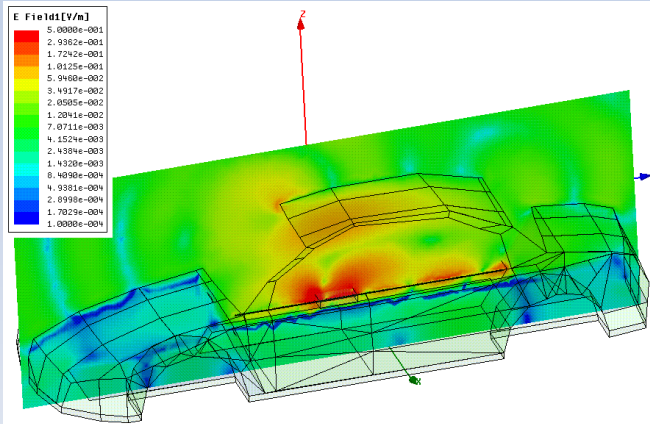

Mesh: 254,966

CPU time: 34m41s (Pentium M, 2GHz)

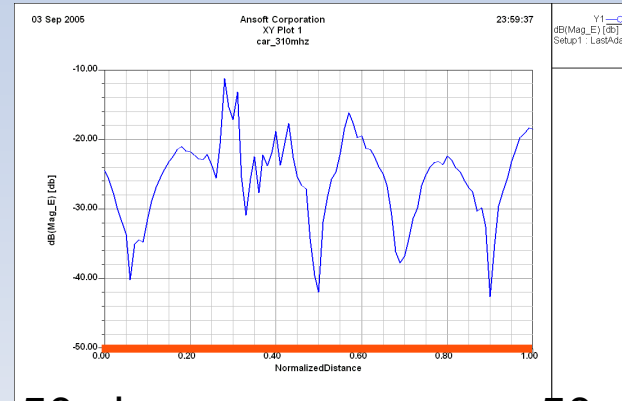

50 ohm

50 ohm

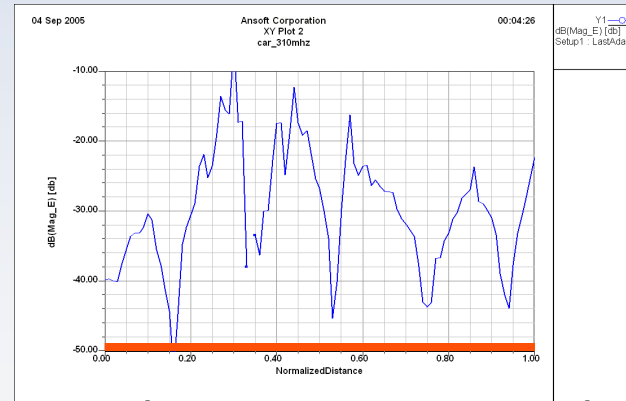

50 ohm

1k ohm

One more sample

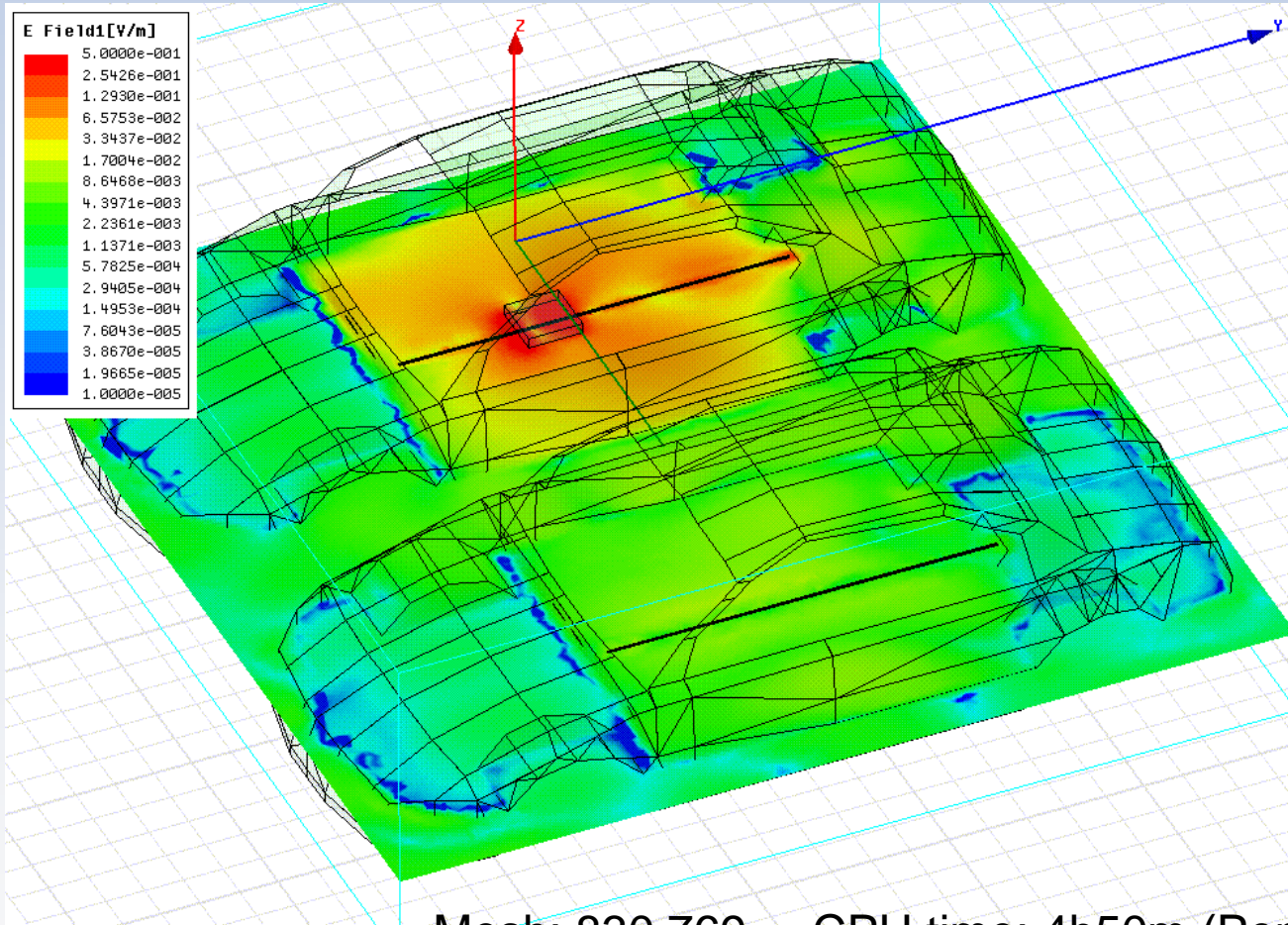

The Virtual Test The Whole Car Body

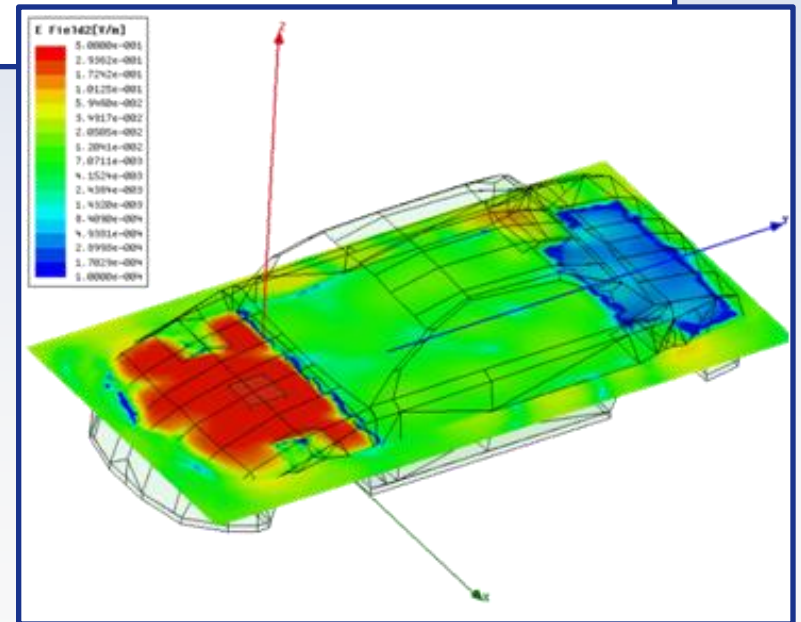
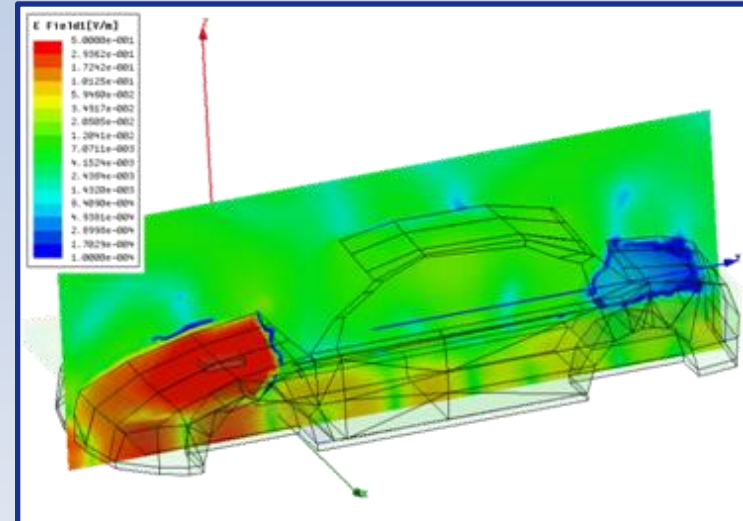
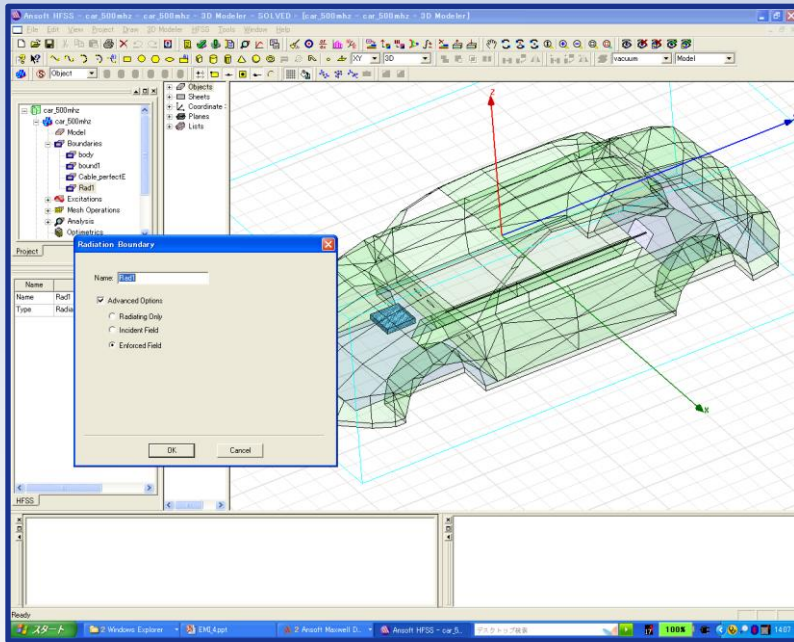

- **EMC in power electronics systems can be studied in a simulation environment by considering:**
 - Frequency-dependent system impedances (parasitics)
 - Electrical dynamics of switching devices
 - Radiation effects using full-wave FEM
- **Software Integration of Simplorer, Q3D, HFSS allows efficient system simulation**