



# CENTRIFUGATION



**Presenter : Dr Anurag Yadav.**

**Father Muller Medical College, Mangalore**

# Contents:

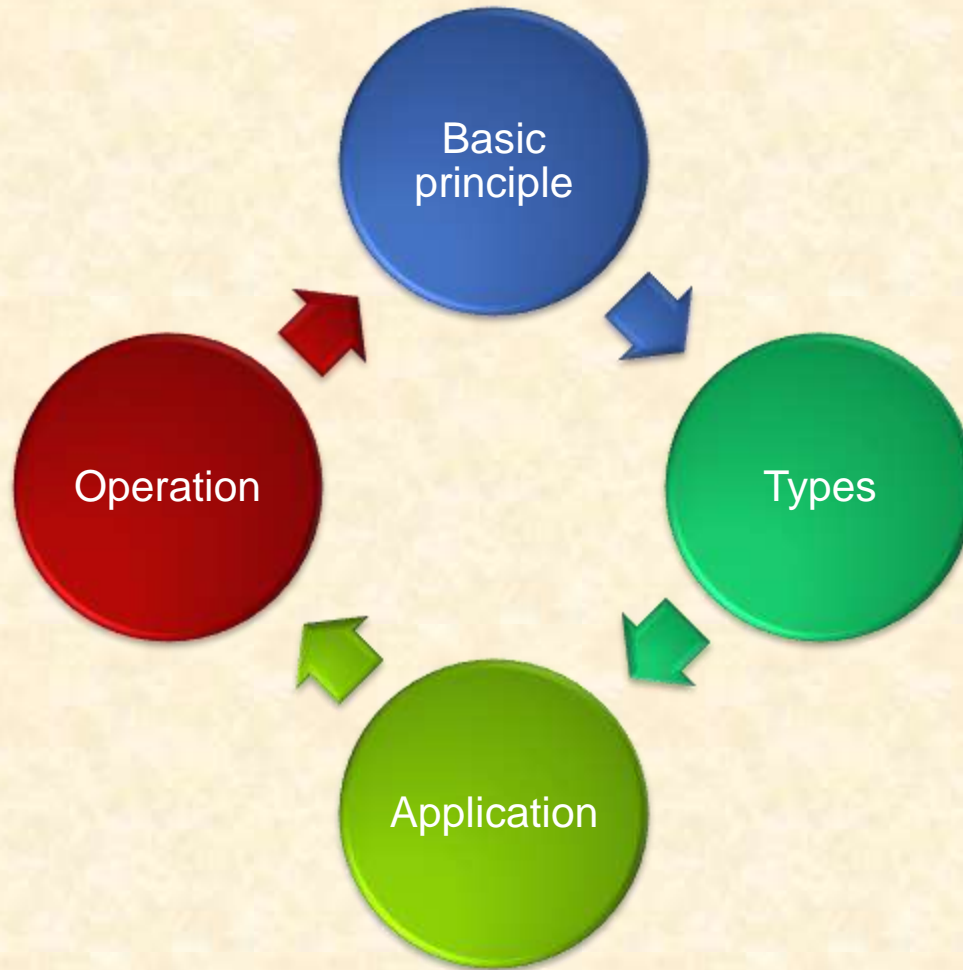

# Definition:

- Biological centrifugation is a process that uses centrifugal forces to separate and purify mixture of biological particle in a liquid medium.
- It is key technique for isolating and analysing the cells, subcellular fractions, supramolecule complexes and isolated macromolecules such as proteins and nucleic acids.



# History:

- The first analytical ultracentrifuge was developed by Svedberg in 1920



# Basic principle

The basic physics on which the centrifuge works is gravity and generation of the centrifugal force to sediment different fractions.

- Rate of sedimentation depends on ----- applied **centrifugal field (G)** being directed radially outwards
- G depends on
  1. Angular velocity ( $\omega$  in radians / sec) .
  2. Radial distance (r in cms) of particle from axis of rotation

- **$G = \omega^2 r$**

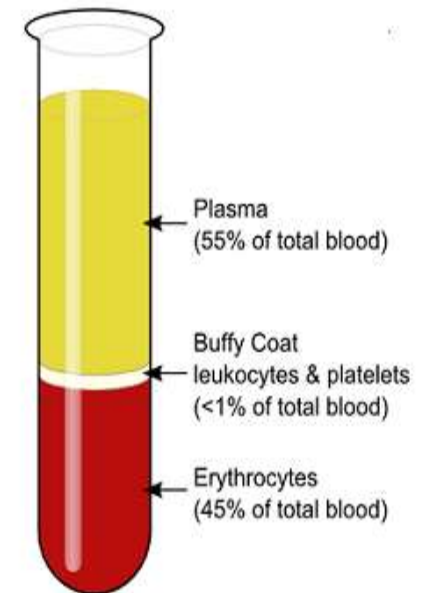

# Armoured casing

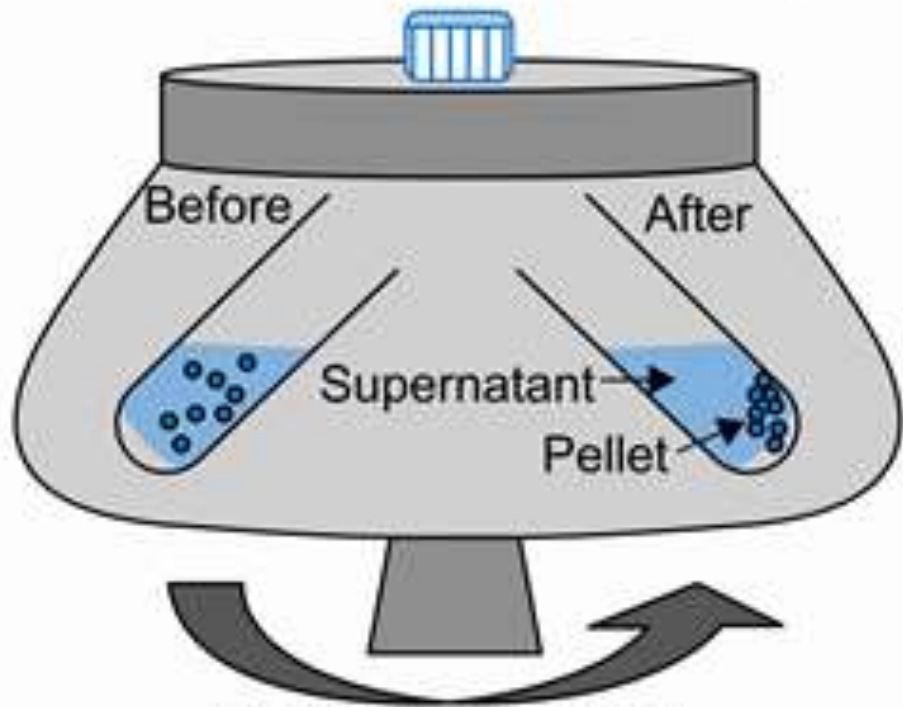

Rapidly rotating rotor



# Rate of sedimentation

- Depends on factors other than CF
- Mass of particle ---Density & Volume
- Density of medium
- Shape of particle
- Friction



# Separation by Sedimentation

Weight	100 kg	30 kg	10 kg	10 kg	8	1
Material	Iron	Stone	Iron	Stone	Cotton	Iron

Sedimentation

Higher density

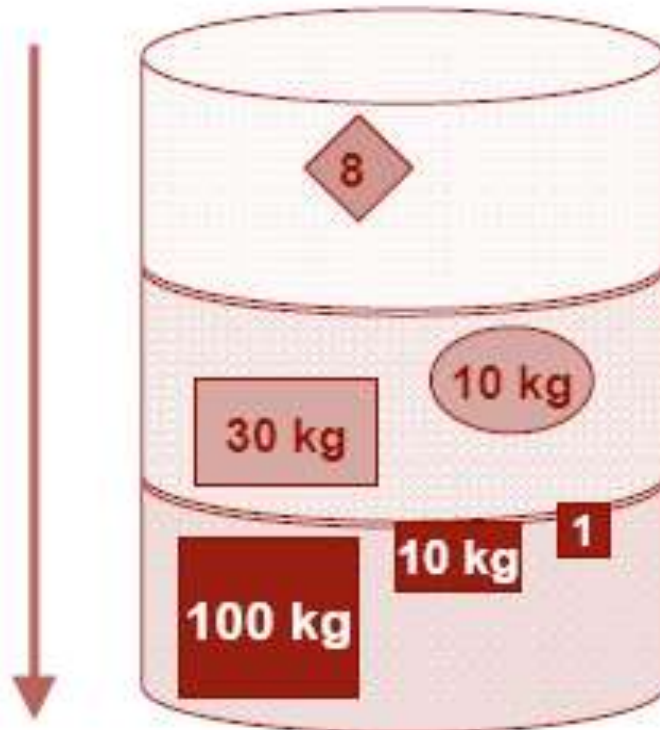

- Mass
- Density
- Shape



# Sedimentation time

- Depends on ,
  1. **Size** of particle
  2. **Density difference** b/w particle and medium
  3. **Radial distance** from the axis of rotation to liquid meniscus (**rt**)
  4. **Radial distance** from the axis of rotation to the bottom of the tube (**rb**)



## THE FACTORS ON WHICH THESE WORKS ARE

More dense a biological structure, faster it sediments in centrifugal force.

More massive biological particle, faster it moves in centrifugal field.

Dense the buffer system, slower particle moves.

Greater the frictional coefficient, slower a particle will move

Greater the centrifugal force, faster particle sediments

Sedimentation rate of a given particle will be zero when density of particle and the surrounding medium are equal.



- Common feature of all centrifuges is the central motor that spins a rotor containing the samples to be separated.



# Types of centrifuge

Desk top  
centrifuges

High speed  
centrifuges

Ultracentrifuges

Analytical

Preparative



# Types of rotor

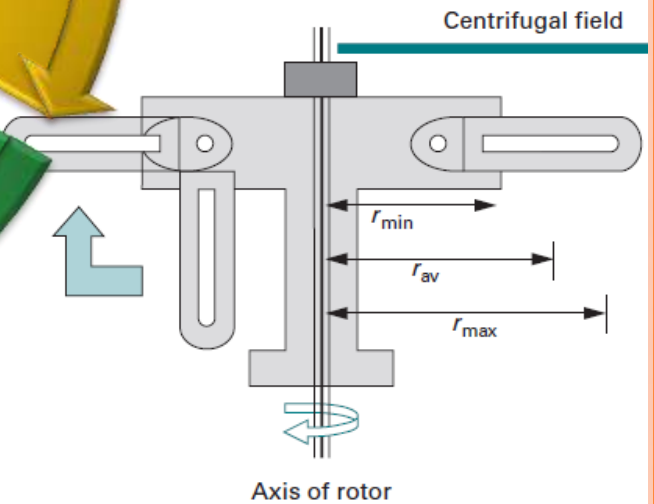
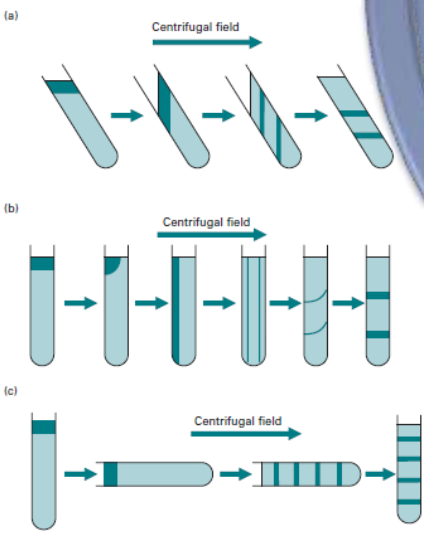
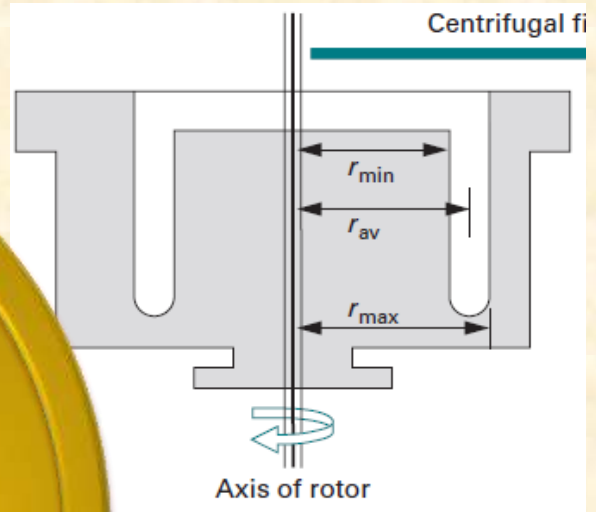
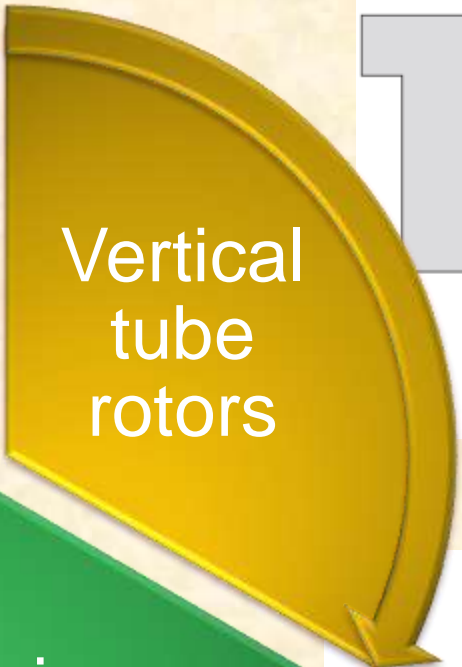
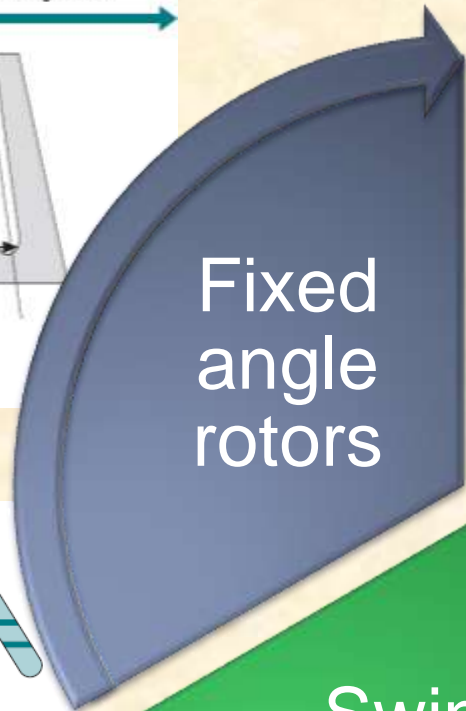
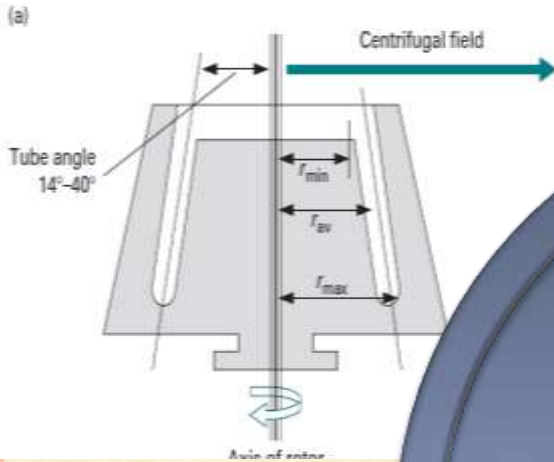

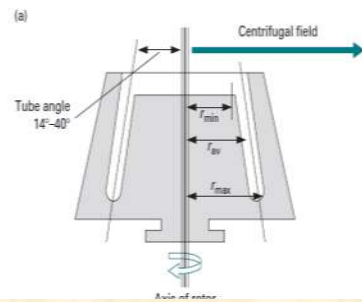

# Types of rotor

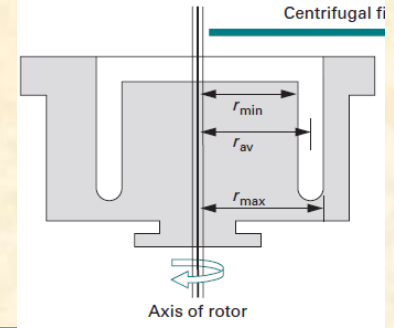

## Fixed angle rotors

- Tubes are held at angle of 14 to 40° to the vertical.
- Particles move radially outwards, travel a short distance.
- Useful for differential centrifugation
- Reorientation of the tube occurs during acceleration and deceleration of the rotor.

## Vertical tube rotors

- Held vertical parallel to rotor axis.
- Particles move short distance.
- Time of separation is shorter.
- Disadvantage: pellet may fall back into solution at end of centrifugation.



# Types of rotor

## Swinging-bucket rotors

- Swing out to horizontal position when rotor accelerates.
- Longer distance of travel may allow better separation, such as in density gradient centrifugation.
- Easier to withdraw supernatant without disturbing pellet.
- Normally used for density-gradient centrifugation.

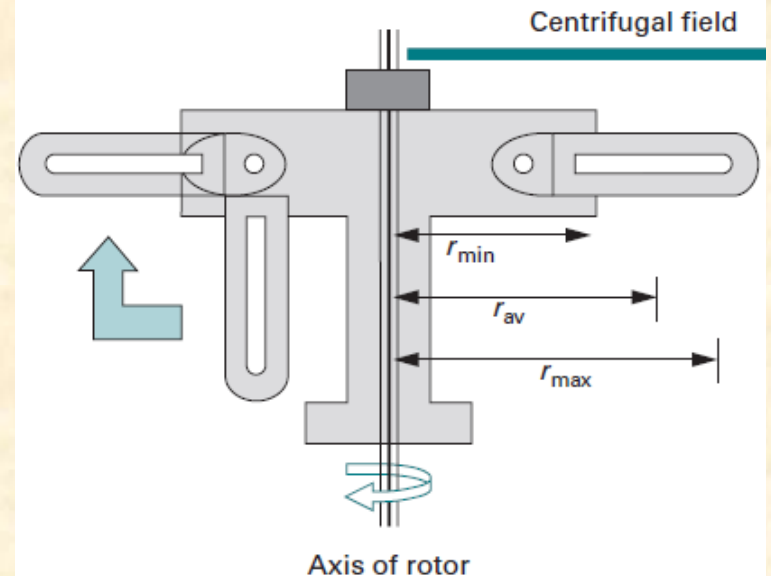

# Separation

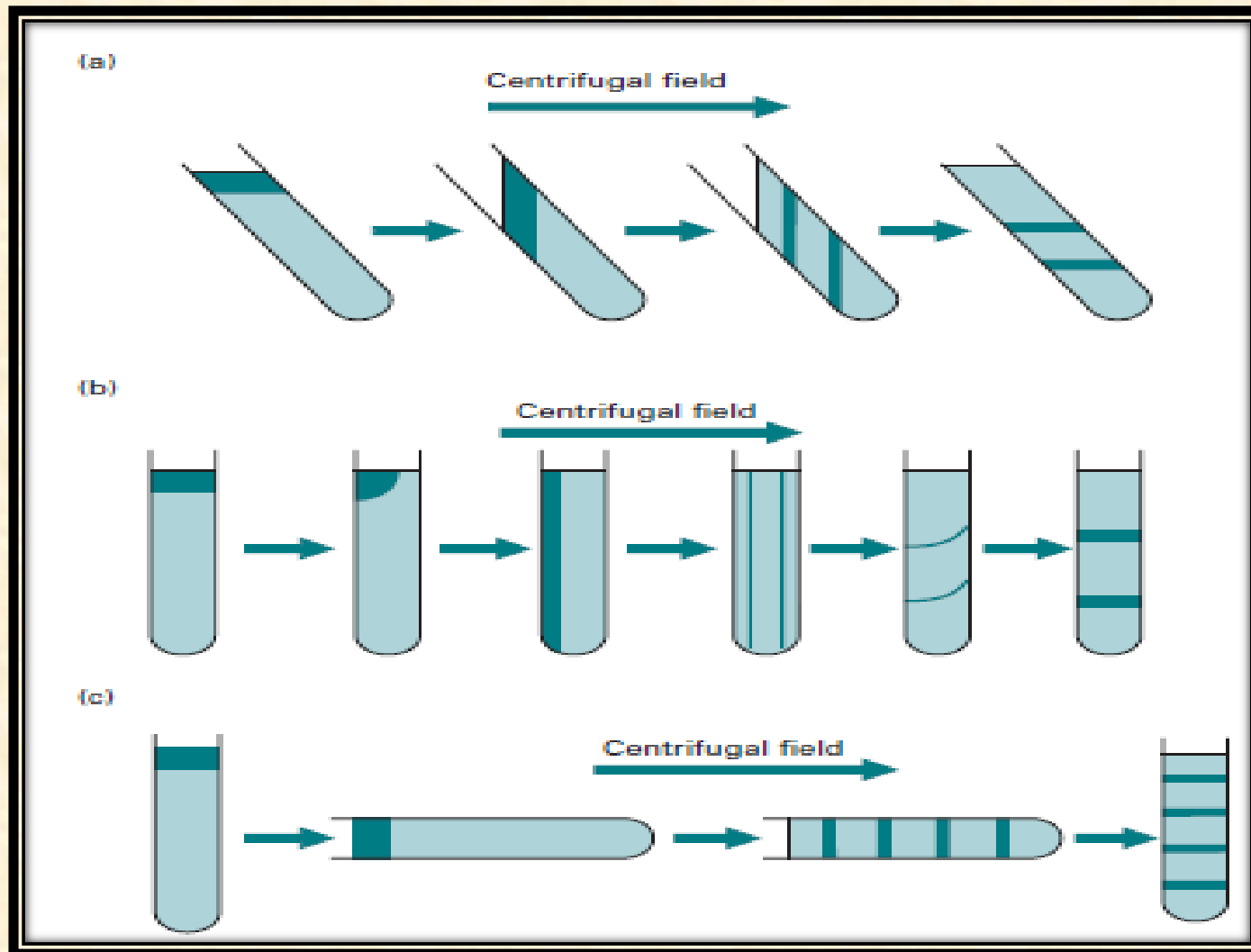



# Small microfuges

- work with speed- 8000-13000 rpm & RCF 10000g
- for rapid sedimentation of small volumes (1-2 min)
- Eg : Blood , Synaptosomes  
( effect of drugs on biogenic amines) 2



# Desk top centrifuge

- Very simple and small.
- Maximum speed of 3000rpm
- Do not have any temperature regulatory system.
- Used normally to collect rapidly sedimenting substances such as blood cells, yeast cells or bulky precipitates of chemical reactions.



# High speed centrifuges

- Maximum speed of 25000rpm, providing 90000g centrifugal forces.
- Equipped with refrigeration to remove heat generated.
- Temperature maintained at 0-4<sup>0</sup>C by means of thermocouple.
- Used to collect microorganism, cell debris, cells, large cellular organelles, precipitates of chemical reactions.
- Also useful in isolating the sub-cellular organelles(nuclei, mitochondria, lysosomes)



# Ultracentrifuges

- Operate at speed of 75,000rpm, providing the centrifugal force of 500,000g.
- Rotor chamber is sealed and evacuated by pump to attain vacuum.
- Refrigeration system (temp 0-4°C).
- Rotor chamber is always enclosed in a heavy armor plate.
- Centrifugation for isolation and purification of components is known as preparatory centrifugation, while that carried out with a desire for characterization is known as analytical centrifugation.



# Preparative centrifugation

- Is concerned with the actual isolation of biological material for subsequent biochemical investigations.
- Divided into two main techniques depending on suspension medium in which separation occur.
  - Homogenous medium – differential centrifugation
  - Density gradient medium – density gradient centrifugation



# 1. Differential centrifugation

- Separation is achieved based in the size of particles in differential centrifugation.
- Commonly used in simple pelleting and obtaining the partially pure separation of subcellular organelles and macromolecules.
- Used for study of subcellular organelle, tissues or cells (first disrupted to study internal content)



- During centrifugation, larger particles sediment faster than the smaller ones.
- At a series of progressive higher g-force generate partially purified organelles.

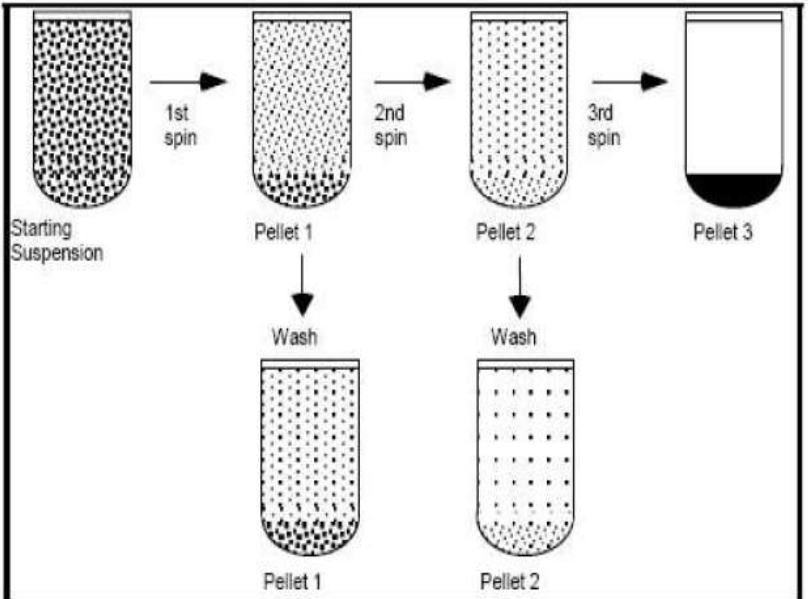

**DIFFERENTIAL CENTRIFUGATION**

Repeated centrifugation at progressively higher speeds will fractionate cell homogenates into their components.

Centrifugation separates cell components on the basis of size and density. The larger and denser components experience the greatest centrifugal force and move most rapidly. They sediment to form a pellet at the bottom of the tube, while smaller, less dense components remain in suspension above, a portion called the supernatant.

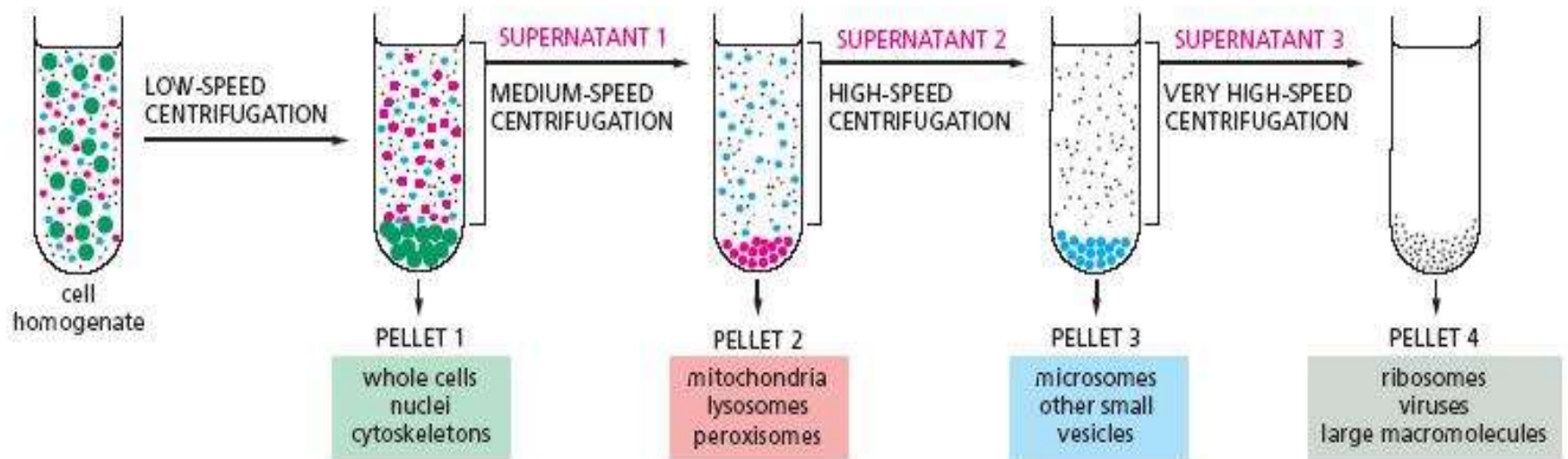

- In spite of its reduced yield differential centrifugation remains probably the most commonly used method for isolation of intracellular organelle from tissue homogenates because of its;
  - relative ease
  - Convenience
  - Time economy
- Drawback is its poor yield and fact that preparation obtained never pure.





## 2. Density gradient centrifugation

- It is the preferred method to purify subcellular organelles and macromolecules.
- Density gradient can be generated by placing layer after layer of gradient media such as sucrose in tube, with heaviest layer at the bottom and lightest at the top in either.
- Classified into two categories:



Rate-zonal  
(size)  
separation



Isopycnic  
(density)  
separation



○ Gradient material used are:

- Sucrose (66%, 5<sup>0</sup>C)
- Silica sols
- Glycerol
- CsCl
- Cs Acetate
- Ficoll (high molecular wgt sucrose polymer & epichlorhydrin)
- Sorbitol
- Polyvinylpyrrolidone



## 2.1 Rate zonal centrifugation

- Gradient centrifugation.
- Take advantage of particle size and mass instead of particle density for sedimentation.
- Ex: for common application include separation of cellular organelle such as endosomes or proteins ( such as antibodies)

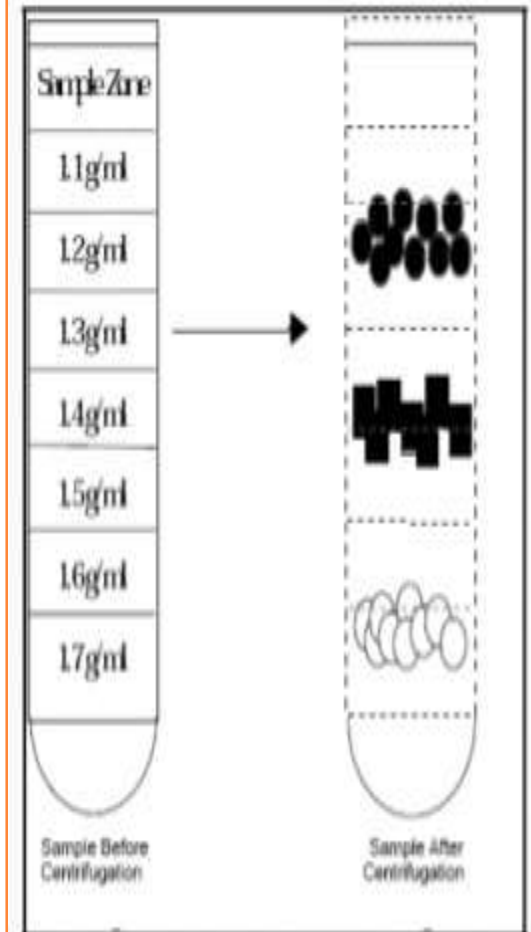

## 2.1 Rate zonal centrifugation

- Criteria for successful rate-zonal centrifugation:
  - Density of sample solution must be less than that of the lowest density portion of the gradient.
  - Density of sample particle must be greater than that of highest density portion of the gradient.
  - Path length of gradient must be sufficient for the separation to occur.
  - Time is important, if you perform too long runs, particles may all pellet at the bottom of the tube.

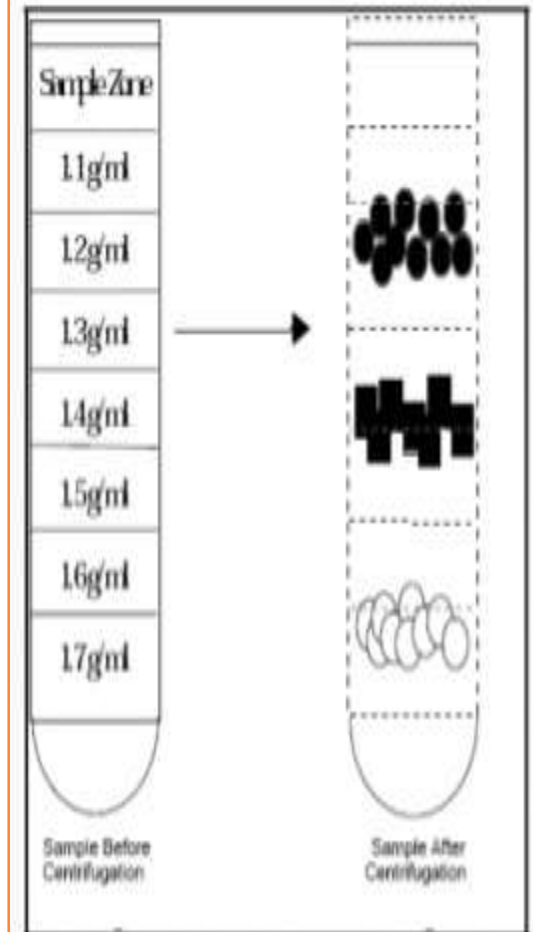

## 2.2 Isopycnic centrifugation

- Particle of a particular density will sink during centrifugation until a position is reached where the density of the surrounding solution is exactly the same as the density of the particle.
- Once quasi-equilibrium is reached, the length of centrifugation does not have any influence on the migration of particle.
- Ex: separation of Nucleic acid in CsCl (Cesium chloride) gradient.

Figure 3. ISOPYCNIC (DENSITY) SEPARATION

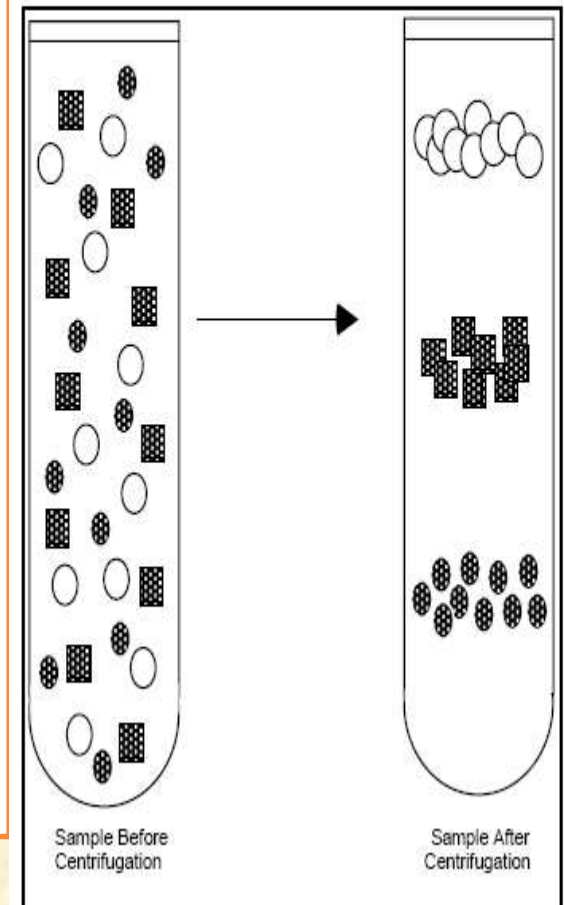

## Rate-Zonal

## Isopycnic

Synonym	S-zonal, sedimentation velocity	Density equilibrium, sedimentation equilibrium
Gradient	<ul style="list-style-type: none"><li>•Shallow,</li><li>•Maximum gradient density less than the least dense sedimenting specie,</li><li>•Gradient continuous.</li></ul>	<ul style="list-style-type: none"><li>•Steep,</li><li>•Maximum gradient density greater than that of the most dense sedimenting specie,</li><li>•Continuous or discontinuous gradients.</li></ul>
Centrifugation	<ul style="list-style-type: none"><li>•Incomplete sedimentation,</li><li>•Low speed,</li><li>•Short time</li></ul>	<ul style="list-style-type: none"><li>•Complete sedimentation till equilibrium is achieved,</li><li>•High speed,</li><li>• Long time.</li></ul>
Separation	RNA- DNA hybrids, ribosomal subunits, etc.,	DNA, plasma lipoproteins, lysosomes, mitochondria, peroxisomes, etc.,

# Analytical centrifugation

- Speed – 70000 rpm, RCF – 5 lakh g
- Motor, rotor ,chamber that is refrigerated and evacuated and optical system
- Optical system has light absorption system ,schleiren system & Rayleigh interferometric system
- 2 cells – analytical cell and counterpoise cell

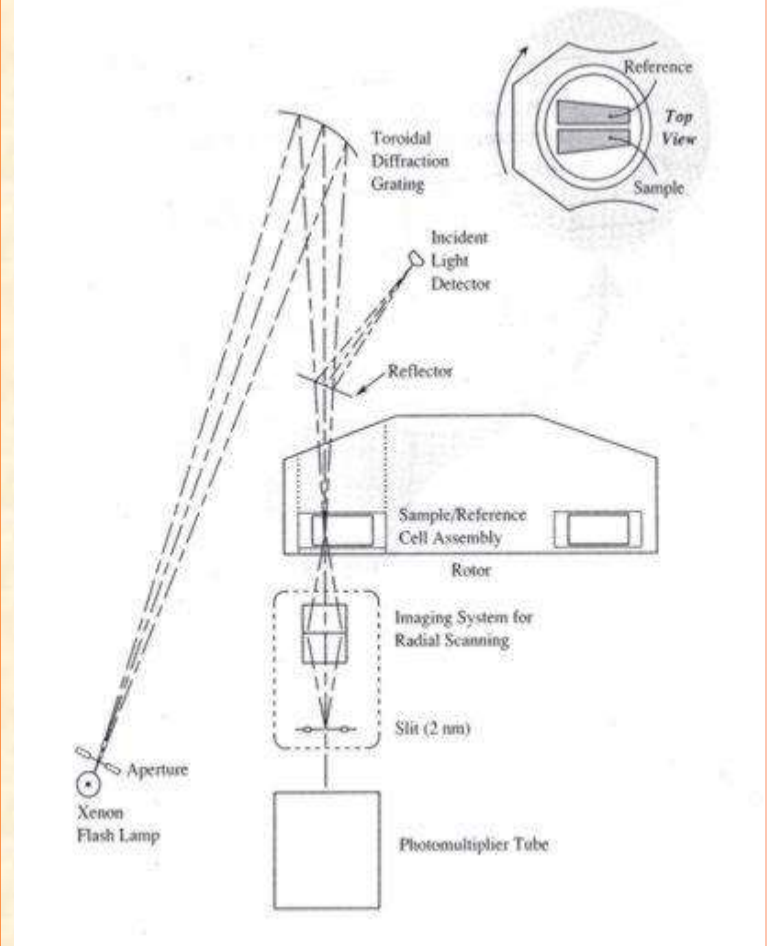

- Optics used – schlieren optics or Rayleigh interference optics
- At beginning , peak of refractive index will be at meniscus.
- With progress of sedimentation, macromolecules move down – peak shifts giving direct information about the sedimentation characteristics.

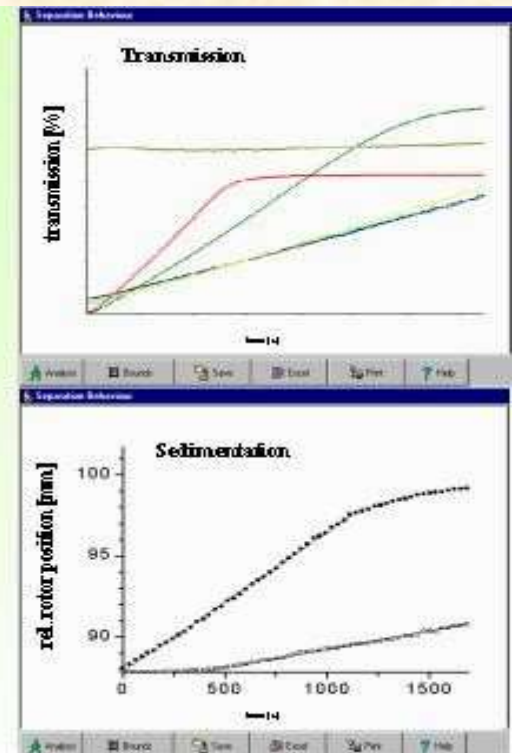
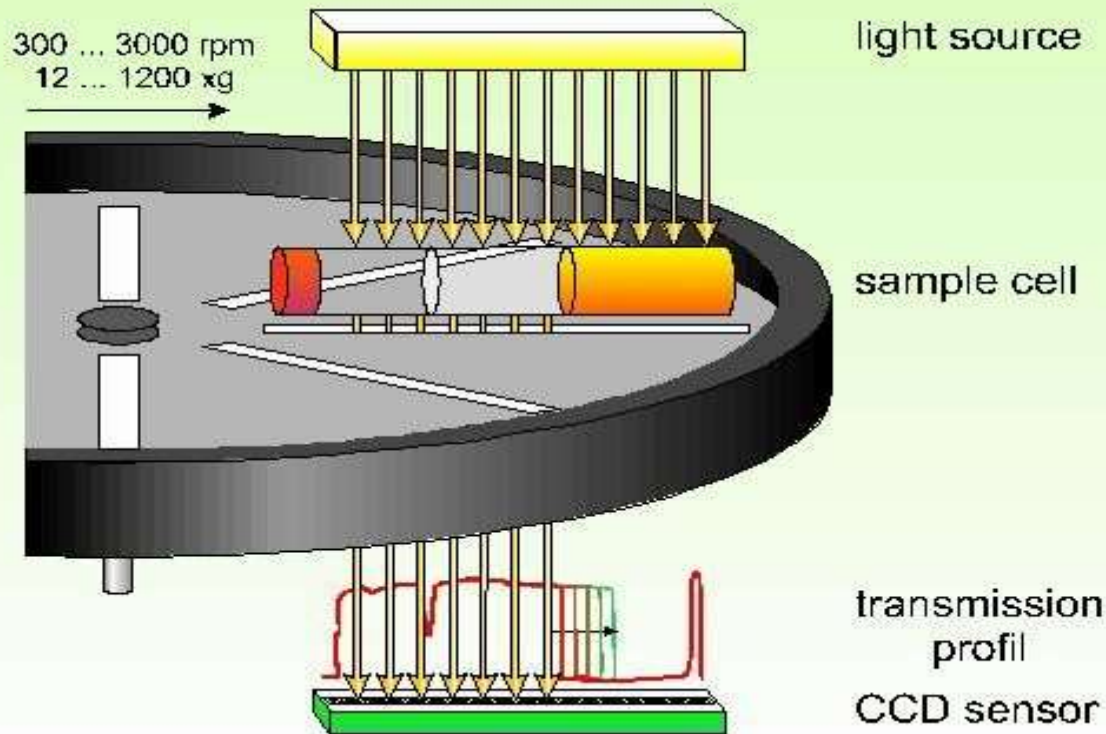



## **Analytical centrifugation**

- Purity of macromole
- Relative molecular mass of solute (within 5% SD)
- Change in relative molecular mass of supermolecular
- complexes
- Conformational change of protein structure
- Ligand-binding study



## Types of Centrifuges & applications

Characteristic	Types of centrifuge		
	Low Speed	High Speed	Ultracentrifuge
Range of Speed (rpm)	1-6000	1000-25,000	20-80,000
Maximum RCF (g)	6000	50,000	6,00,000
Refrigeration	some	Yes	Yes
Applications			
Pelleting of cells	Yes	Yes	Yes
Pelleting of nuclei	Yes	Yes	Yes
Pelleting of organelles	No	Yes	Yes
Pelleting of ribosomes	No	No	Yes
Pelleting of Macromolecules	No	No	Yes

# Operation

Tubes recommended by their manufacturer should be used.

Top of tube should not protrude so far above the bucket.

Properly balanced- weight of racks, tubes, and content on opposite side of a rotor should not differ by more than 1%. (Centrifuges auto balance are available).

Should centrifuge before unstopper the tubes.

Cleanliness –minimizing the possible of spread of infection (hep Virus).

Spillage and break of tube should be considered as the bloodborne pathogen hazard.

Speed of centrifuge should be checked once 3m.

Centrifuge timer to be checked per week.

# Application

- In clinical laboratory, centrifugation is used to;
  - Remove cellular elements from blood to provide cell free plasma or serum for analysis.
  - Remove chemically precipitated protein from an analytical specimen.
  - Separate protein bound from free ligand in immunochemical and other assay.
  - Separation of the subcellular organelle, DNA, RNA.
  - Extract solutes in biological fluids from aqueous to organic solvents.
  - Separate lipid components.



# References :

- **Tietz** – Clinical Chemistry And Molecular Diagnostic
- **Keith Wilson and John Walker** – Principle And Technique In Biochemistry And Molecular Biology.
- **Avinash Upadhyay** – Biophysical Chemistry.
- Internet sources.

**THANK YOU**

