



**CORE/SHELL
NANOPARTICLES:
CLASSES, PROPERTIES,
SYNTHESIS MECHANISMS,
CHARACTERIZATION, AND
APPLICATIONS**

Presented By,
S.Shashank Chetty
2nd Year, M.Tech,
NAST

OUTLINE

- ❑ Introduction
- ❑ Different Shaped Nanoparticles
- ❑ Importance of Core/Shell Nanoparticles
- ❑ Classes of Core/Shell Nanoparticles
- ❑ Inorganic/Inorganic Core/Shell Nanoparticles
- ❑ Inorganic/Organic Core/Shell Nanoparticles
- ❑ Organic/Inorganic Core/Shell Nanoparticles
- ❑ Organic/Organic Core/Shell Nanoparticles
- ❑ Approaches for Core/Shell Nanoparticle Synthesis
- ❑ Techniques, classification, and mechanism of core/shell nanoparticle synthesis applications
- ❑ Conclusion
- ❑ Reference



INTRODUCTION

- ❑ **Nanomaterials** have, by definition, one or more dimension in the nanometer scale (100 nm) range and subsequently show novel properties from their bulk materials.
- ❑ The most important characteristics, among many others, on a nanoscale are as follows:
 - ❑ First, the small size of the particles, which leads to an **increased surface area to volume ratio** and as a result the domain where quantum effects predominate is entered.
 - ❑ Second, the increasing surface area to volume ratio leads to an increase in the dominance of the **surface atoms** of the nanoparticle over those in its interior.
- ❑ However, broadly these all techniques essentially fall into **three categories**: (i) condensation from vapor, (ii) synthesis by chemical reaction, and (iii) solid-state processes such as milling.
- ❑ By using the above-mentioned techniques, not only pure nanoparticles but also hybrid or coated nanoparticles (with hydrophilic or hydrophobic materials depending on the suitability of the applications) can be synthesized.

❑ Bulk → single nanoparticles → heterogeneous, composite or sandwich colloidal

DIFFERENT SHAPED NANOPARTICLES

Figure: **Different core/shell nanoparticles:** (a)

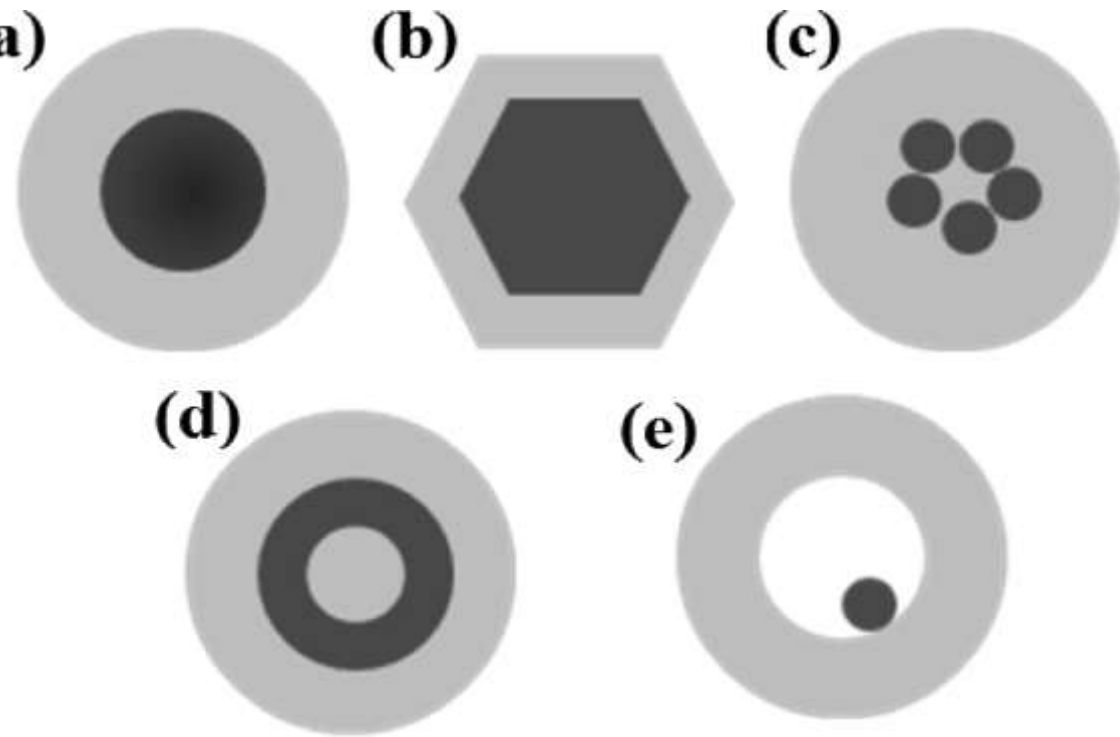
(a) spherical core/shell nanoparticles;

(b) hexagonal core/shell nanoparticles;

(c) multiple small core materials coated by single shell material;

(d) nanomatryushka material;

(e) movable core within hollow shell material.



The properties of nanoparticles are **not only size** dependent but are also linked with the actual **shape**.

For **example**, certain properties of magnetic nanocrystals such as the blocking temperature, magnetic saturation, and permanent magnetization are all dependent on particle size, but the coercivity of the nanocrystals totally depends on the particle shape because of surface anisotropy effects.

Other nanoparticle physical and chemical properties such as catalytic activity and selectivity, electrical and optical properties, sensitivity to surface-enhanced Raman scattering (SERS) and the plasmon resonance and melting point are also all highly shape-dependent.

IMPORTANCE OF CORE/SHELL NANOPARTICLES

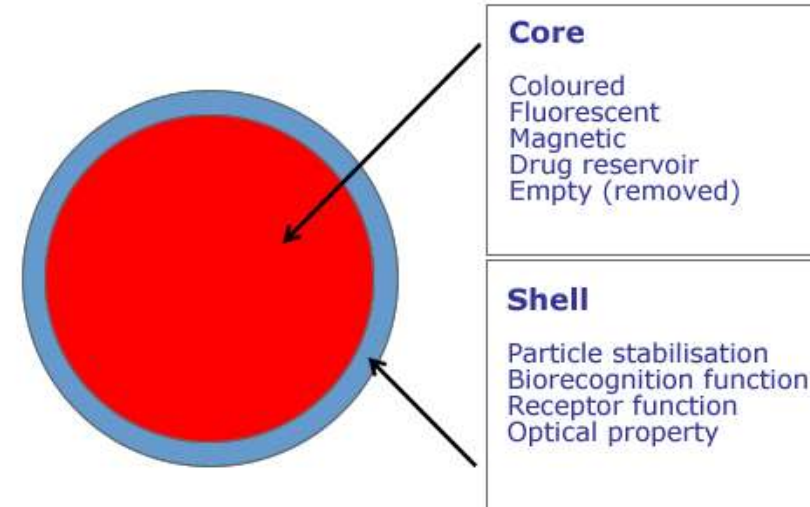
- ❑ Emerged at the frontier between materials chemistry and many other fields, such as electronics, biomedical, pharmaceutical, optics, and catalysis.
- ❑ Core/shell nanoparticles are highly functional materials with **modified properties**.
- ❑ Because of the shell material coating, the properties of the core particle such as reactivity decrease or thermal stability can be modified, so that the overall particle stability and dispersibility of the core particle increases.
- ❑ The purpose of the coating on the core particle are many fold, such as surface modification, the ability to increase the functionality, stability, and dispersibility, controlled release of the core, reduction in consumption of precious materials, and so on.
- ❑ Nano- and microsized hollow particles are used for different purposes such as microvessels, catalytic supports, adsorbents, lightweight structural materials and thermal and electric insulators.

CLASSES OF CORE/SHELL NANOPARTICLES

□ The core/shell type nanoparticles can be broadly defined as comprising a **core** (inner material) and **a shell** (outer layer material).

□ These can consist of a wide range of **different combinations** in close interaction, including

- inorganic/inorganic,
- inorganic/organic,
- organic/inorganic, and
- organic/organic materials.



□ The choice of shell material of the core/shell nanoparticle is generally strongly dependent on the end **application and use**.

□ **Multiple core core/shell particles** are formed when a single shell material is coated onto many small core particles together

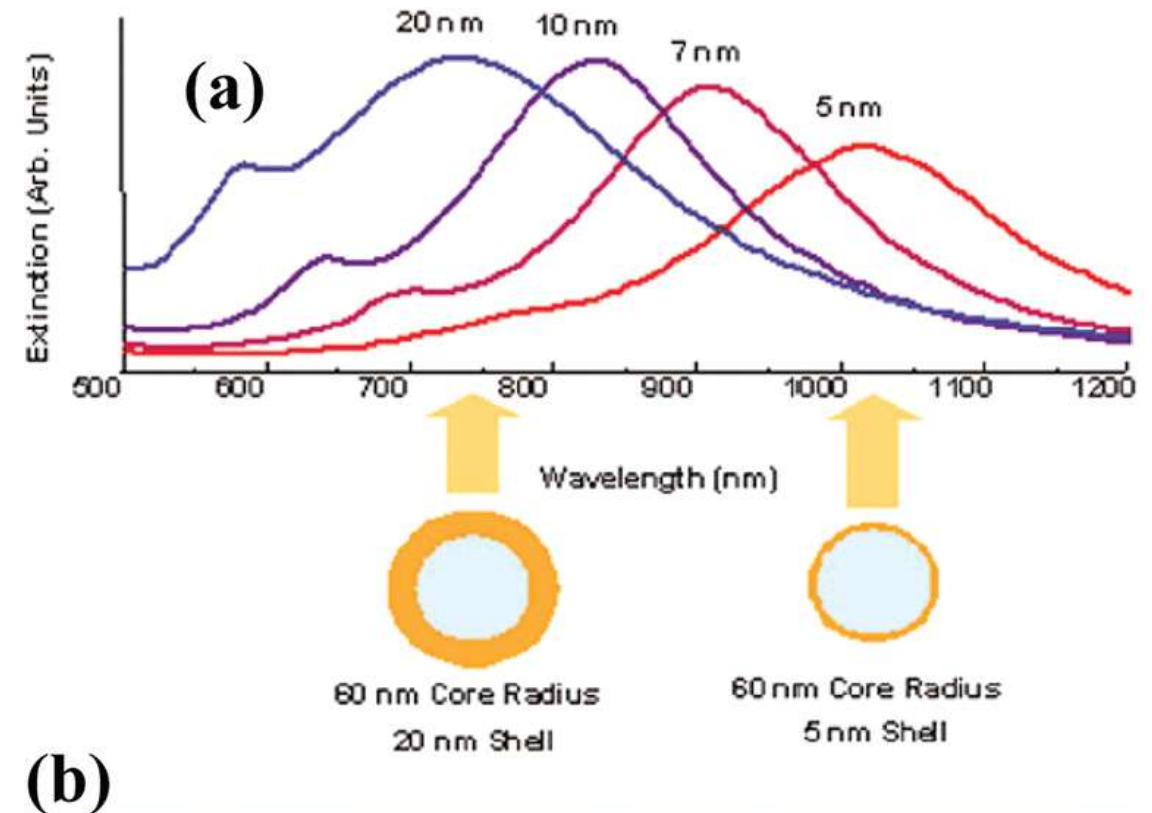
INORGANIC/INORGANIC CORE/SHELL NANOPARTICLES

- ❑ The most basic **advantages of the silica** coating compared with other inorganic (metal or metal oxide) or organic coatings are as follows:
 - ❑ It reduces the bulk conductivity and increases the suspension stability of the core particles.
 - ❑ In addition, silica is the most chemically **inert** material available; it can block the core surface without interfering in the redox reaction at the core surface.
- ❑ Silica coatings can also be used to modulate the position and intensity of the surface plasmon absorbance band since **silica is optically transparent**.
- ❑ As a result, chemical reactions at the core surface can be studied spectroscopically.
- ❑ **Gold coating** on any particles enhances many physical properties, such as the chemical stability by protecting the core material from oxidation and corrosion, the biocompatibility, the bioaffinity through functionalization of amine/thiol terminal groups, and the optical properties.
- ❑ **Other shell metals** such as Ni, Co, Pd, Pt and Cu are also important for some specific applications in the field of catalysis, solar energy absorption, permanent magnetic properties etc.

□ Similar to the **size-dependent color** of pure gold nanoparticles, the optical response of gold nanoshells depends dramatically on the relative size of the core nanoparticle as well as the thickness of the gold shell.

□ By varying the relative core and shell thicknesses, the color of such gold nanoshells can be varied across a broad range of the optical spectrum spanning the visible and the near-infrared spectral regions as shown in Figure.

□ Semiconductor Core/Shell Nanoparticles- particles are used for medical or bioimaging purposes, enhancement of optical properties, light-emitting devices, nonlinear optics, biological labeling, improving the efficiency of either solar cells or the storage capacity of electronics devices, modern electronics field applications



❑ **In Type I**, this category, the energy band gap of the shell material is wider than the band gap of the core material.

❑ The electrons and holes are confined within the core area because both the conduction and the valence band edges of the core are located within the energy gap of the shell.

❑ As a result, the emission energy, $\hbar\omega_{PL}$, is determined by **the energy gap of the core material**.

❑ The shell is used to passivate the surface of the core with the goal of improving its overall optical properties.

❑ Another role of the shell is to separate the more optically active core surface from its surrounding environment.

❑ The wider band gap shell material increases the stability against photobleaching of the semiconductor core.

❑ However, the increasing thickness of the shell layer reduces the material surface activity of the core surface; as a result, quantum yield also reduces.

❑ These types of semiconductor particles especially those made from CdSe/CdS,

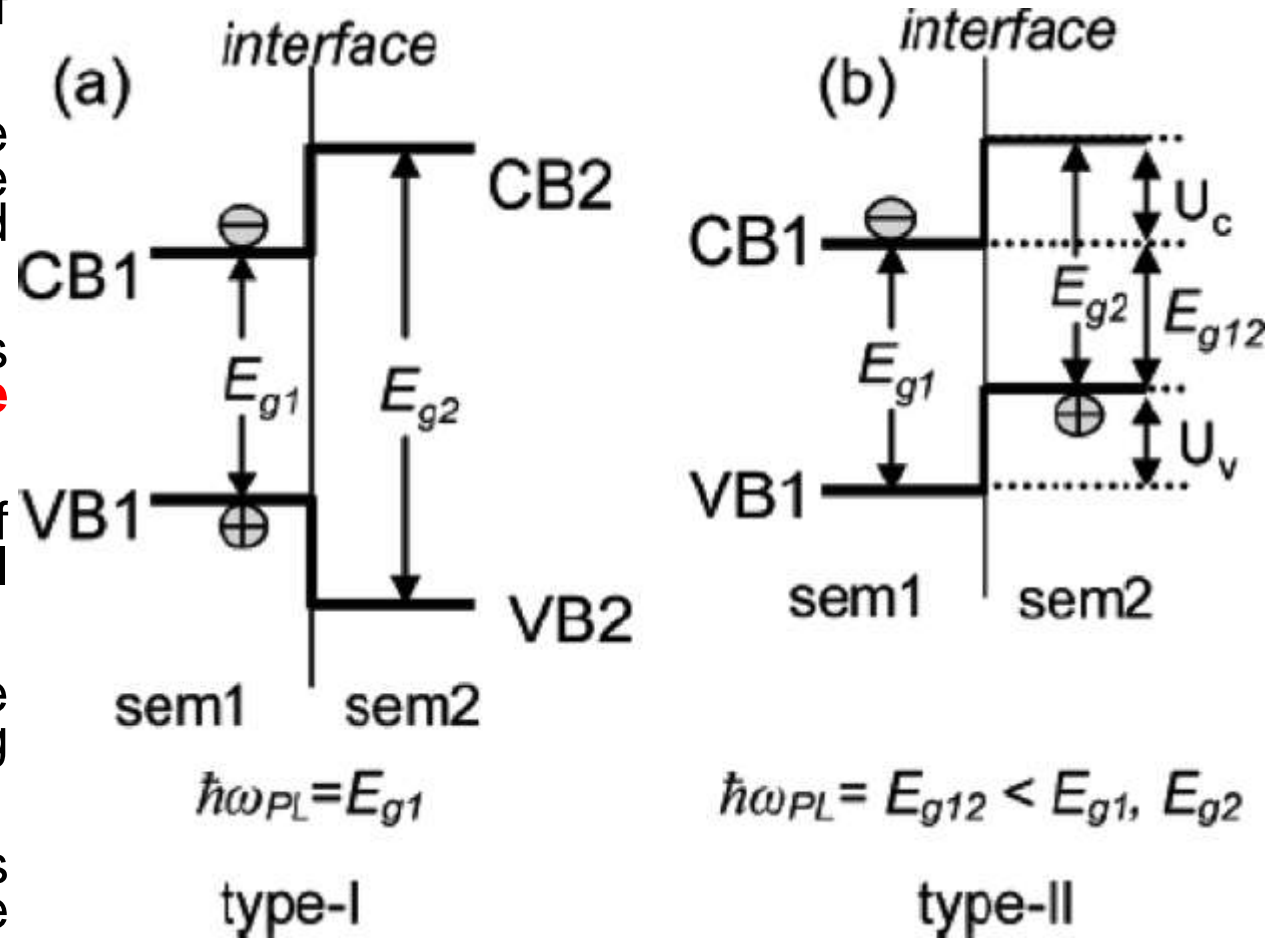


Figure: (a) Type I and (b) type II semiconductor/semiconductor core/shell materials. Sem1 = core material, Sem2 = shell material.

❑ **In type II**, the narrower band gap shell material is grown over the wider band gap core material.

❑ In this case, both hole and electron charges are partially localized on the shell materials and emission wavelengths can be tuned by changing the thickness of the shell.

❑ Within this category, the most extensively studied systems are CdS/CdSe and ZnS/CdSe.

❑ Here the types of particles have low quantum yields and higher resistance against photobleaching, whereas the quantum yield can be improved by coating another semiconductor material of a wider band gap.

❑ For example, the quantum yield (QY) of CdSe-coated CdS core/shell nanoparticles in aqueous media is 20%.

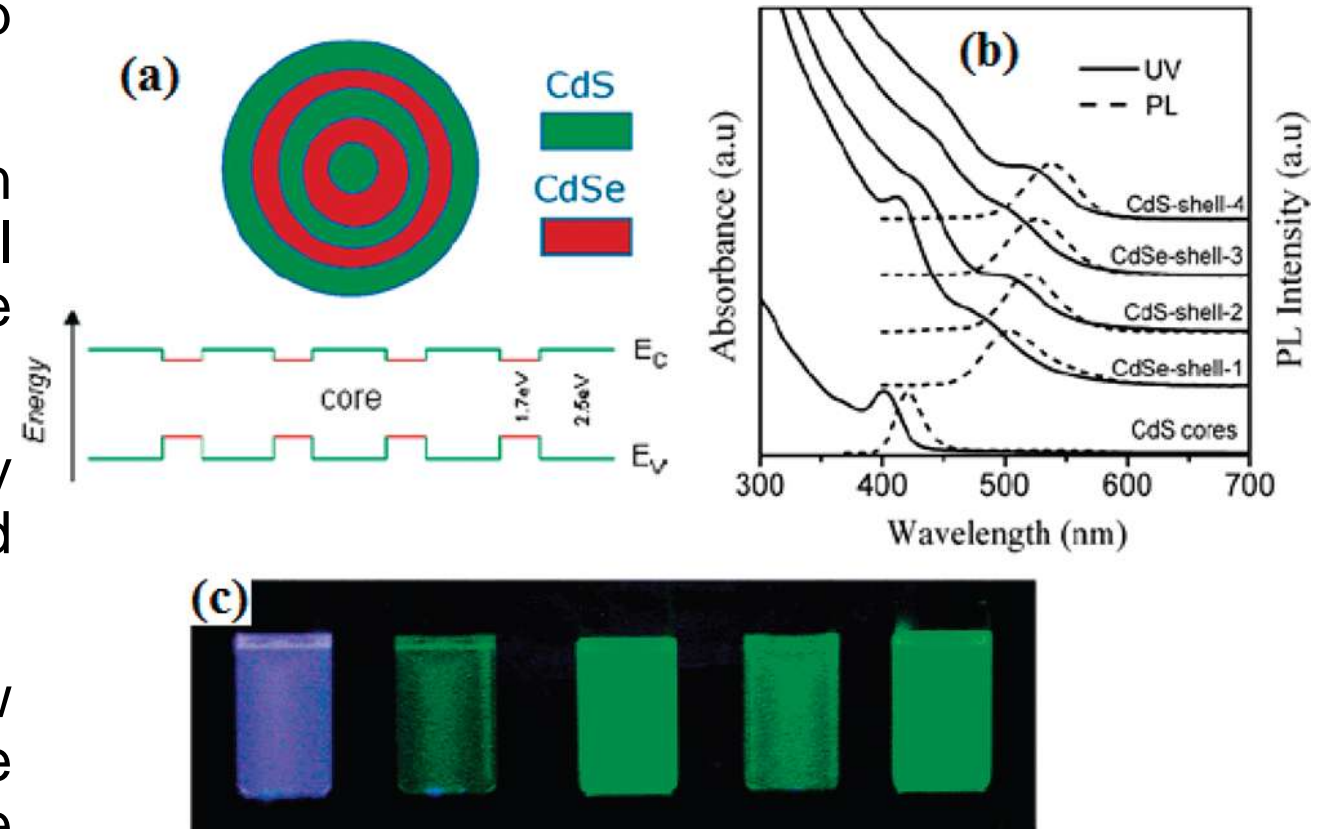


Figure: (a) Schematic diagram of an onion-like structure of alternate multifold CdS (1.7 eV)/CdSe (2.5 eV) structure and its corresponding energy diagram. (b) UV-vis absorption and PL spectra. (c) Corresponding luminescence image for the samples under UV lamp irradiation.

INORGANIC/ORGANIC CORE/SHELL NANOPARTICLES

- ❑ Inorganic/organic core/shell nanoparticles are made of metal, a metallic compound, metal oxide, or a silica core with a polymer shell or a shell of any other high density organic material.
- ❑ The advantages of the organic coating on the inorganic material are many fold.
- ❑ One example is the fact that the **oxidation stability** of the metal core is increased when otherwise the surface atoms of the metal core can be oxidized to the metal oxide in a normal environment.
- ❑ In addition, they exhibit enhanced biocompatibility for bioapplications.
- ❑ The polymer-coated inorganic materials have a broad spectrum of applications, ranging from catalysis to additives, pigments, paints, cosmetics, and inks.
- ❑ In many applications, the particles are coated to stabilize them in the suspension media, and the stability of such a colloidal suspension depends mainly on the attractive and repulsive forces between the particles.
- ❑ There are four different types of **forces**: (i) van der Waals forces, (ii) induced short-range isotropic attractions, (iii) electrostatic repulsion, and (iv) steric repulsion.

- ❑ Magnetic nanoparticles with any polymer coating are used mainly for magnetic recording, magnetic sealing, electromagnetic shielding, MRI, and especially in the biological field for specific drug targeting, magnetic cell separation, etc.
- ❑ **Dextran**, a polysaccharide polymer composed of exclusively R-D-glucopyranosyl units with varying degrees of chain length and branching, is also widely used as a shell coating.
- ❑ Dextran is used as a polymeric shell because of its high biocompatibility.
- ❑ It in turn increases the biocompatibility of the magnetic nanoparticles to the extent that they can be used in in vivo applications.
- ❑ Side-chain-functionalized dextran coated ultrasmall superparamagnetic iron oxides (USPIO) show a prolonged blood residence time, which allows these USPIO particles to access the macrophages located in deep pathological tissues (such as lymph nodes, kidney, brain, osteoarticular tissues, etc.).
- ❑ Dextran-coated Fe nanoparticles are also used for labeling red blood cells (RBC) in cell separation studies using high gradient magnetic chromatography (HGMC).

- ❑ The most common polymers used as organic coatings on silica cores are poly(methyl methacrylate) (PMMA), polystyrene (PS),³⁴⁷ poly(3-aminophenylboronic acid),³⁴⁸ and poly(vinyl chloride) (PVC) conductive polymers such as polyaniline (PANI), polypyrrole (PPy), and polythiophene (PTh), .
- ❑ Natural polymers such as cellulose
- ❑ Polymer-coated AgCl nanoparticles are useful for sensor applications.
- ❑ Polymer-coated CaCO₃ shows improved mechanical properties as a filler material and is useful in different applications.
- ❑ Polystyrene-coated CaCO₃ is widely used in the manufacture of paint, paper, rubber, plastics, etc.
- ❑ It was found that instead of pure CaCO₃, a poly(butylene tetracarboxylate) (PBT) coating on stearic acid-modified CaCO₃ improves the mechanical, thermal, and structural properties of the CaCO₃.
- ❑ As an example, the tensile strength of stearic acid-modified CaCO₃ increases from 56 to 58.9 MPa because of the PBT coating; 80% weight fraction of the overall material.

ORGANIC/INORGANIC CORE/SHELL NANOPARTICLES

- ❑ The core of this particular class of core/shell nanoparticles is made of a polymer, such as polystyrene, poly(ethylene oxide), polyurethane, poly(vinyl benzyl chloride), poly(vinyl pyrrolidone), dextrose, surfactant, and different copolymers, such as acrylonitrilebutadienestyrene, poly-(styreneacrylic acid), and styrenemethyl methacrylate.
- ❑ The shell can also be made from different materials, such as metals, metal oxides, metal chalcogenides or silica.
- ❑ The inorganic material, especially a metal oxide coating on an organic material, is beneficial in several respects, such as increased strength of the overall material, resistance to oxidation, thermal and colloidal stability, and abrasion resistance.
- ❑ At the same time, these particles also show polymeric properties such as excellent optical properties, flexibility, and toughness, and in addition they can improve the brittleness of the inorganic particles.
- ❑ Phadtare et al. synthesized gold-coated polyurethane microsized core/shell particles for applications where biocatalytic activity was required in such applications as pepsin digestion.
- ❑ Another interesting application of these types of particles is for the synthesis of hollow inorganic particles by using an organic material as the sacrificial core.

CORE/SHELL NANOPARTICLES

- ❑ In this category, both the core and shell particles are made of a polymer or another organic material.
- ❑ These classes of particles are known as “**smart particles**” and have a wide range of applications in different fields, such as drug delivery, biosensing, chemical separation, biomaterials, and catalysis.
- ❑ The advantages of having a polymer coating on another polymer is to modify the physical properties of the overall material, such as toughness or the glass transition temperature.
- ❑ The glass transition temperature is an important characteristic of a polymer because below this temperature polymers are in what is called a “**glassy state**”.
- ❑ When the temperature of the material crosses the glass transition temperature, the mechanical properties of the polymers change from those of a glass (brittle) to a rubber (elastic) material.
- ❑ For example, a polymer coating on a polymer with a different T_g is used to modify latex-based paints. A high T_g core material has the impact of improving the mechanical

- ❑ Polymer/polymer core/shell particles are also extensively used for controlled drug release applications in in vivo systems because of their good biodegradable and drug encapsulation property.
- ❑ Poly(D,L-lactic-co-glycolide) (PLGA) is a biodegradable organic polymer with a high capacity for encapsulating hydrophobic drugs.
- ❑ C-dots coated with a polymer are promising as tools for sensing and imaging subcellular agents because they can be delivered into the cell cytoplasm.

APPROACHES FOR CORE/SHELL NANOPARTICLE SYNTHESIS

- ❑ Approaches for nanomaterial synthesis can be broadly divided into two categories: “top-down” and “bottom-up”.
- ❑ The **“topdown”** approach often uses traditional workshop or microfabrication methods where externally controlled tools are used to cut, mill, and shape materials into the desired shape and order.
- ❑ For example, the most common techniques are lithographic techniques (e.g., UV, electron or ion beam, scanning probe, optical near field), laser-beam processing, and mechanical techniques (e.g., machining, grinding, and polishing).
- ❑ **“Bottom-up”** approaches, on the other hand, exploit the chemical properties of the molecules to cause them to self-assemble into some useful conformation.
- ❑ The most common bottom-up approaches are chemical synthesis, chemical vapor deposition, laser-induced assembly (i.e., laser tapping), self-assembly, colloidal aggregation, film deposition and growth etc.
- ❑ However, the bottom-up approach can produce much smaller sized particles and has the potential to be more cost-effective in the future because of the advantages of absolute precision, complete control over the process, and minimum energy loss compared with that of a topdown approach.

TECHNIQUES, CLASSIFICATION, AND MECHANISM OF CORE/SHELL NANOPARTICLE SYNTHESIS

- ❑ **In general**, core/shell nanoparticles are synthesized using a two-step process, first synthesis of core and second the synthesis of the shell.
- ❑ The synthesis techniques of core/shell nanoparticles can be classified into **two types** depending on the availability of core particles:
 - ❑ (i) the core particles are synthesized and separately incorporated into the system with proper surface modification for coating the shell material;
 - ❑ (ii) the core particles are synthesized in situ, and this is followed by coating of the shell material.
- ❑ The basic **advantage** of external core synthesis is the fact that core particles are available in pure form and hence there is less possibility of impurities on the core surface.
- ❑ Whereas, in in situ synthesis, the main **problem** is that some impurity from the reaction media may be trapped between the core and shell layer.
- ❑ The most important step during synthesis of core/shell particles is to maintain uniform coating and to control the shell thickness.
- ❑ Some of the various synthetic methods for core/ shell particles used by different research groups are precipitation, polymerization, microemulsion, sol-gel condensation, layer by layer adsorption techniques etc.

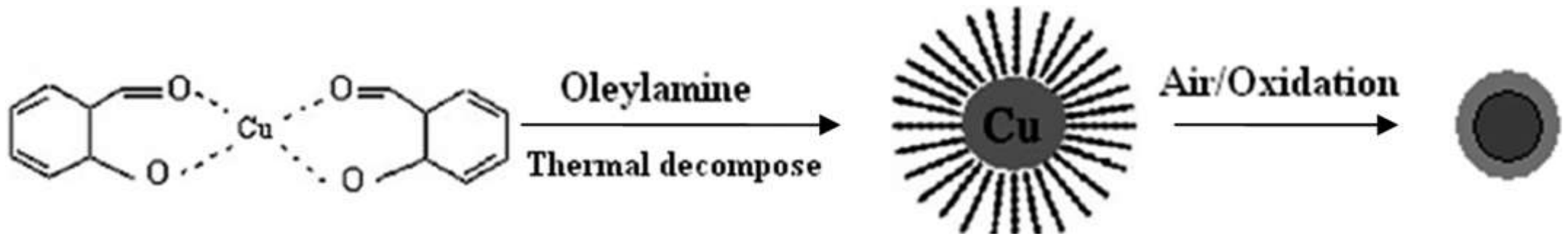


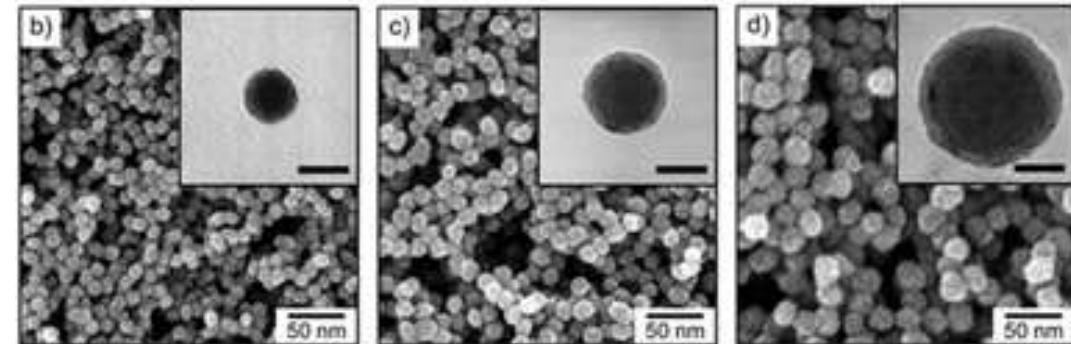
Figure: Schematic diagram for Cu/Cu₂O core/shell nanoparticle synthesis using the thermal decomposition of a metal organic complex

The main difficulties are

- (i) agglomeration of core particles in the reaction media,
- (ii) preferential formation of separate particles of shell material rather than coating the core,
- (iii) incomplete coverage of the core surface, and
- (iv) control of the reaction rate.

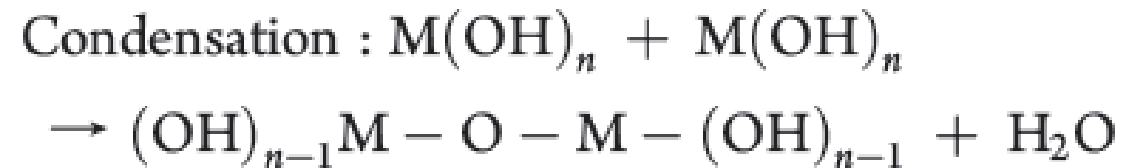
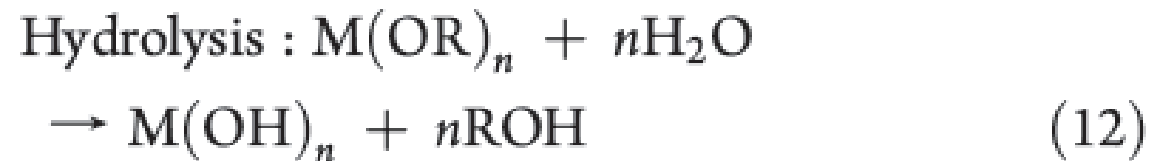


Fig. Silica/PT core/shell nanospheres: (a) a schematic illustration of silica/PT core/shell nanoparticles fabrication using seeded polymerization, and (b–d) SEM images with different diameters of silica nanoparticles (insets: TEM images of a single core/shell nanoparticle, scale bar indicates 10 nm): (b) 11 nm, (c) 16 nm, (d) 26 nm.



SOLGEL METHOD

Step 1. **Mixing.** For the first method, the suspension of colloidal powder or sol is formed by the mechanical mixing of colloidal particles in water at a suitable pH without any precipitation. For the other two methods, metal alkoxide or metal salt are used as precursors, which are hydrolyzed to form hydrated metal hydroxides in the presence of water, which subsequently undergo condensation to form an oxo bridge (MOM). When sufficient MOM bonds are formed in a region, then they cooperatively respond to form colloidal particles or sol. The size of the particles depends on the pH of the medium and the ratio of water to metal alkoxide or metal salt.



Step 2. **Casting.** Since the sol is a low-viscosity liquid, it can be cast into a mold.

Step 3. **Gelation.** With time, the colloidal particles and condensed species link together to form a three-dimensional network with increased viscosity which finally becomes solid.

- ❑ **Step 4. Aging.** The aging of the gel involves maintaining the cast object for a period of time, completely immersed in liquid for polycondensation, syneresis, coarsening and phase transformation.
- ❑ **Step 5. Drying.** The liquid is removed from the interconnected pore network during the drying process.
- ❑ **Step 6. Dehydration or chemical stabilization.** The surface metal-hydroxide bonds are removed in this step, and the material is converted into a stable ultraporous solid with sufficient interconnected porosity, optical transparency, and good mechanical strength.
- ❑ **Step 7. Densification.** After dehydration, solid materials are heated at high temperatures to increase density by reducing the internal porosity.
- ❑ During the last four steps, the shrinkage and densification occurs because of
 - ❑ (1) capillary contraction, (2) condensation, (3) structural relaxation, and (4) viscous sintering.
- ❑ In the first step, the rate of hydrolysis of metal or metalloid alkoxide or salt is affected by some physical parameters such as (i) pH, (ii) substituents, (iii) solvent, and (iv) water.

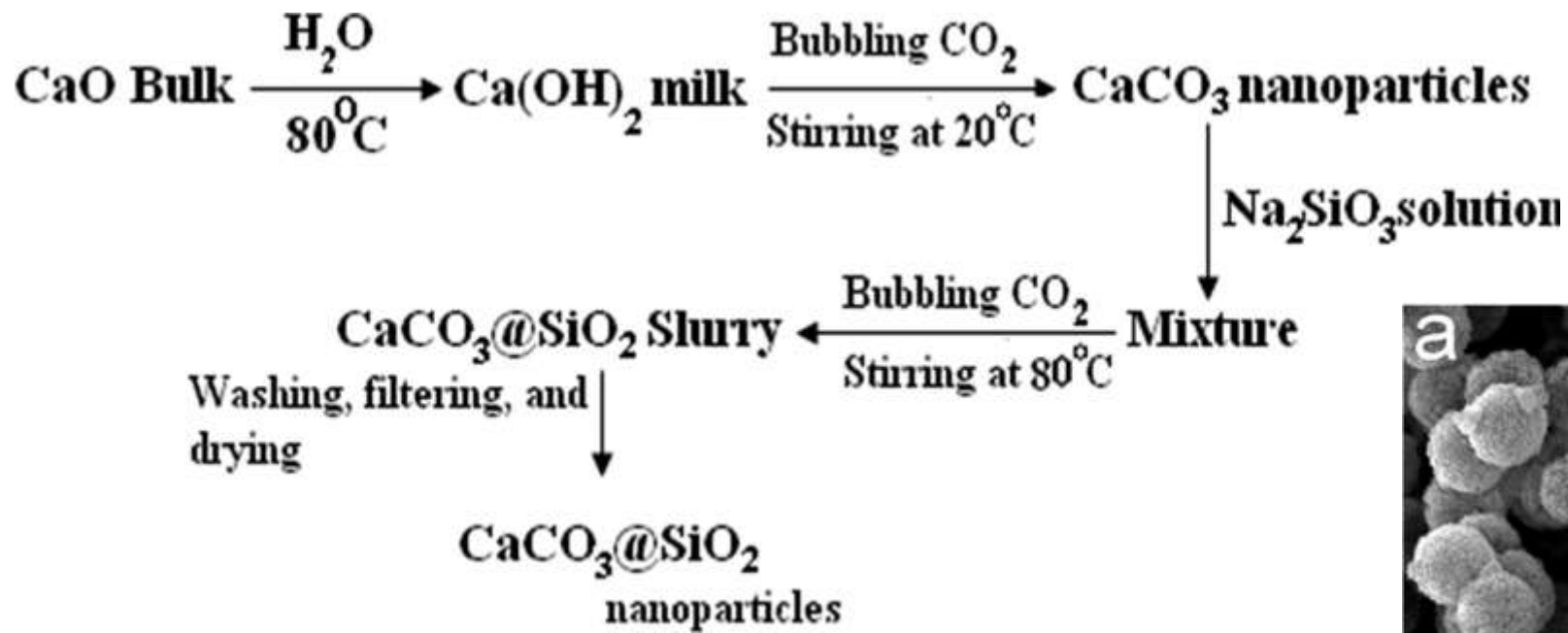


Figure: Reaction steps for $\text{CaCO}_3/\text{SiO}_2$ core/shell nanoparticle formation by precipitation reactions.

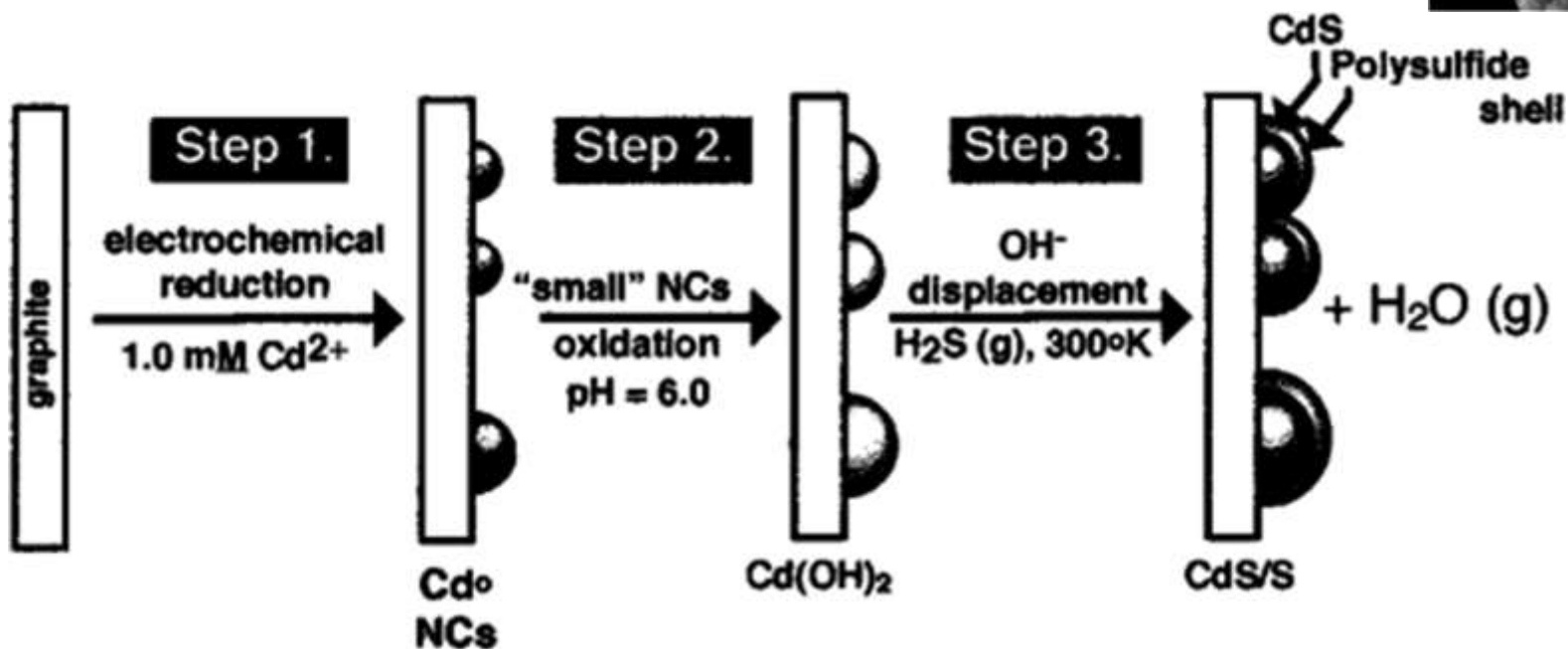
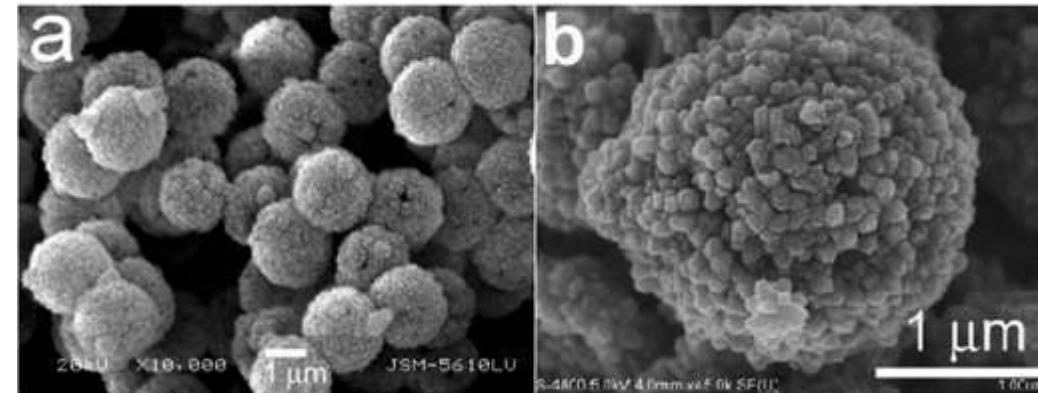
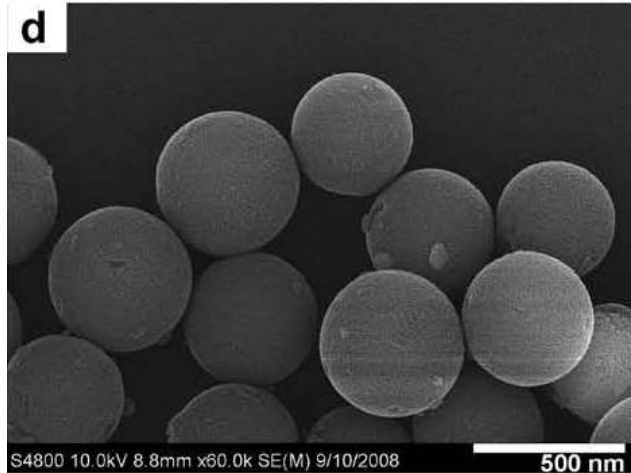
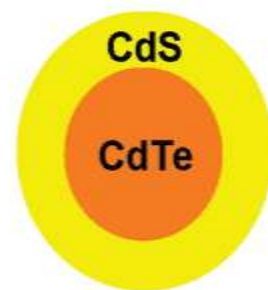
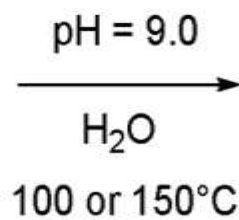


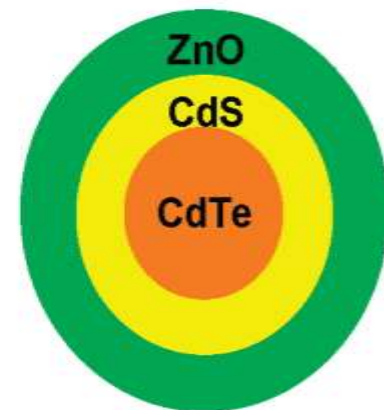
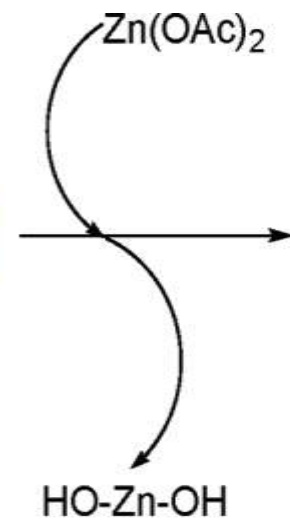
Figure: The electrochemical/chemical (E/C) synthesis of CdS/S core/shell nanocrystals.



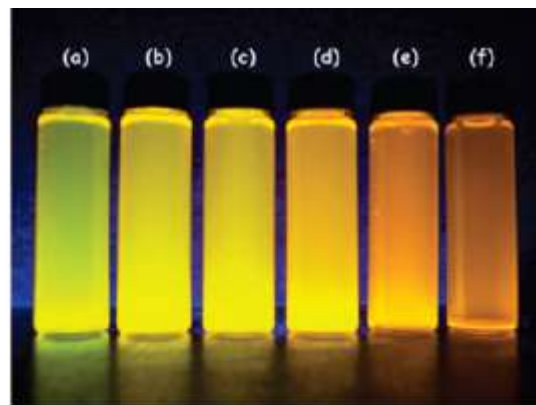
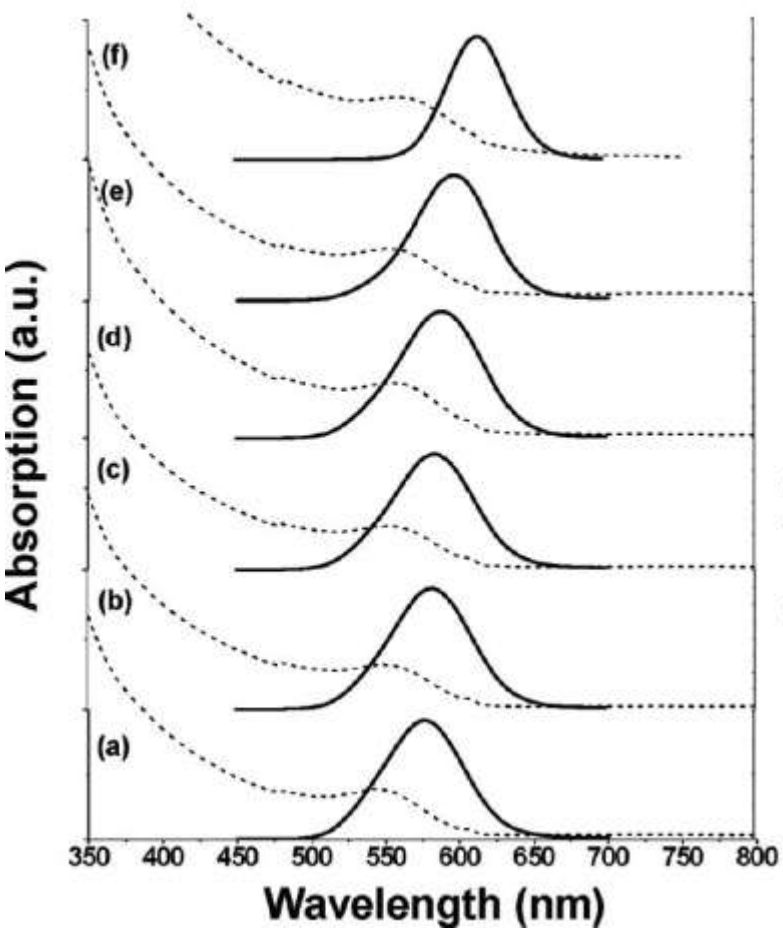
$\text{CdCl}_2 + \text{NaHTe}$



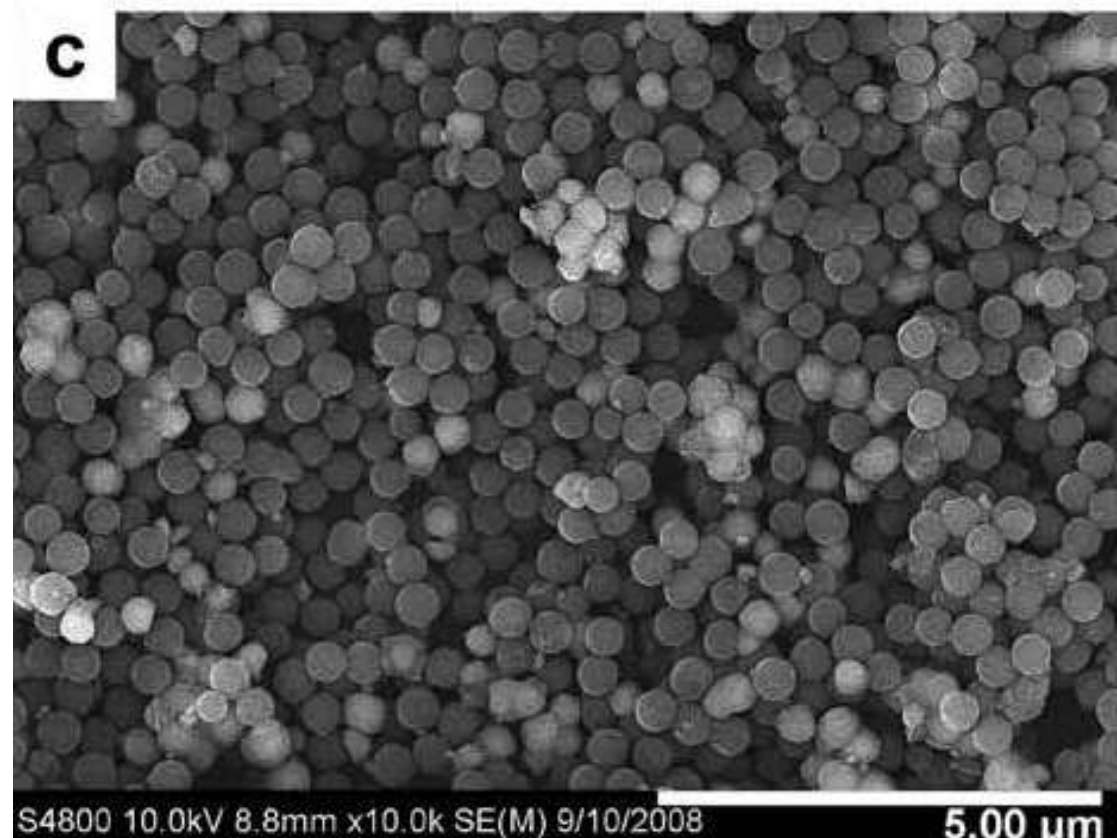
Core/Shell



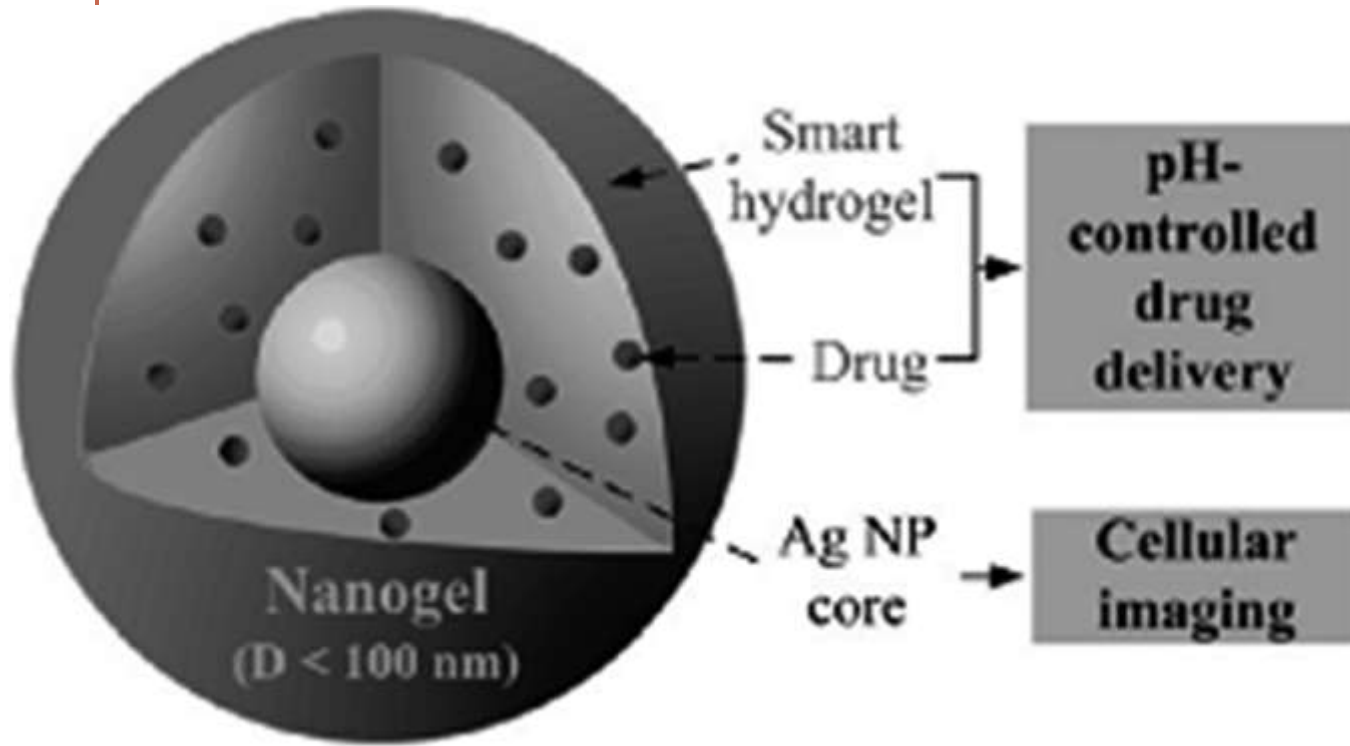
Core/Shell/Shell



QDs	λ_{abs} (nm)	λ_{em} (nm)	PL QY (%)
(a)	543	576	27
(b)	549	582	41
(c)	553	584	41
(d)	554	589	46
(e)	557	596	47
(f)	563	615	25



APPLICATIONS



- ❑ Catalytic, Electronic and Other Applications.
- ❑ By modulating the size, shape, and material of the core, the optics can be tuned and optimized for use in optical devices and applications such as LEDs, detectors, lasers, phosphors, and photovoltaics.

Biomedical Applications- Controlled Drug Delivery and Specific Targeting, Bioimaging, Sensors, Replacement, Support, and Tissues

CONCLUSIONS

- ❑ The future generations of core/shell nanoparticles will exhibit many new properties that will surely result in **new applications with improved performance**.
- ❑ Generally core/shell nanoparticles are well-known for **better stability**, for being able to protect the core material from the surrounding environment, for improved physical and chemical properties, for improved semiconductor properties, for easy biofunctionalization, etc.
- ❑ Most of the recent exciting discoveries show that there is tremendous scope in biomedical applications such as controlled drug delivery and release, targeted drug delivery, bioimaging, cell leveling, biosensors, diagnostics, immunoassays, and many more.
- ❑ In the near future, the development of new materials has the potential for improving the treatment of cancer and many other life threatening diseases.

REFERENCE

- Rajib Ghosh Chaudhuri and Santanu Paria, Core/Shell Nanoparticles: Classes, Properties, Synthesis Mechanisms, Characterization, and Applications, Chem. Rev. 2018, 118, 2272–2402

**CHEMICAL
REVIEWS**

REVIEW

pubs.acs.org/CR

**Core/Shell Nanoparticles: Classes, Properties, Synthesis Mechanisms,
Characterization, and Applications**

Rajib Ghosh Chaudhuri and Santanu Paria*

Thank you for **Kind** Attention