



# NANOLITHOGRAPHY & NANOPATTERNING

BY

ROHAN DEOKAR

# LITHOGRAPHY – A PREVIEW

- ▶ Lithography (Greek for the word *lithos* & *to write (graphein)*) refers to the process invented in 1796 by Aloys Senefelder, where patterns of desired designs were transferred on to a base substrate, mostly using masks.
- ▶ Photolithography is probably the most well established technique & is the main technology used by the microelectronics industry.
- ▶ Nanolithography was the driver in the microelectronics industry to maintain the Moore's Law.

# MOORE'S LAW

- ▶ An empirical observation made in 1965 by Gordon Moore: “number of transistors on an integrated circuit doubles every 24 months.”
- ▶ Nanolithography refers to the technique that allows to define patterns in a surface at ever decreasing length scales.

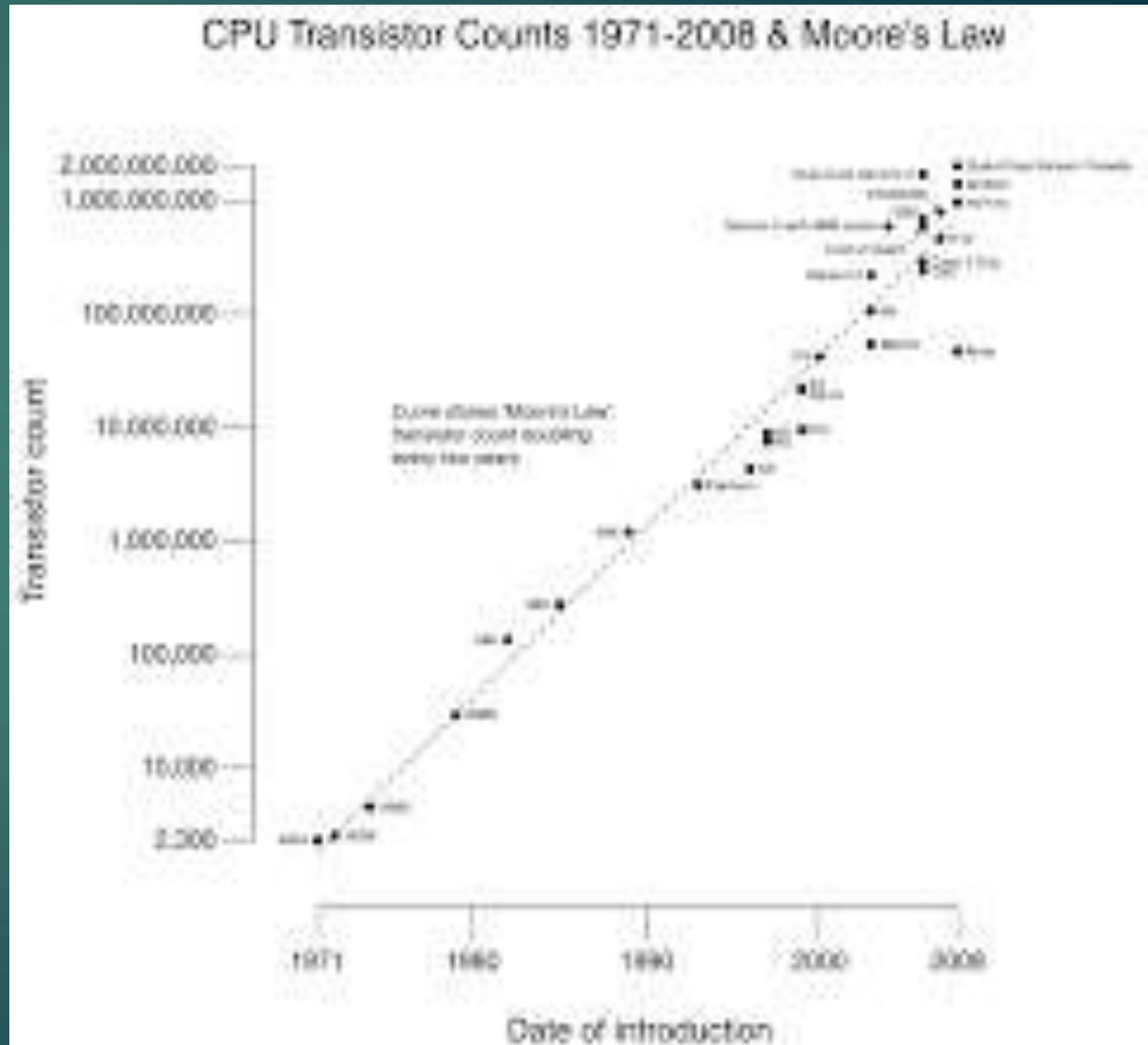

# WHAT IS NANOLITHOGRAPHY???

- ▶ Most experts feel that traditional optical lithography techniques will not be cost effective below 22 nm. At that point, it may be replaced by next generation lithography (NGL) techniques.
- ▶ Nanolithography is the branch of nanotechnology concerned with the study and application of fabricating nanometer-scale structures, meaning patterns with at least one lateral dimension between the size of an individual atom and approximately 100 nm.
- ▶ Nanolithography is used during the fabrication of nanocircuitry or nanoelectromechanical systems (NEMS).

# APPLICATIONS OF NANOLITHOGRAPHY

- ▶ Miniaturization of FET
- ▶ Surface gated quantum devices
- ▶ Quantum dots
- ▶ Wires
- ▶ Grating
- ▶ Zone plates
- ▶ Mask making

# ELECTRON BEAM LITHOGRAPHY

- ▶ Electron Beam Lithography is a specialized technique for creating extremely fine patterns (~ 50 nm).
- ▶ Derived from the early scanning electron microscopes, the technique consists of scanning a beam of electrons across a surface covered with a resist film sensitive to those electrons, thus depositing energy in the desired pattern in the resist film.
- ▶ It is a high resolution patterning technique in which high energy electrons (10-100 keV) are focussed into a narrow beam & are used to expose electron sensitive resists.

# BASIC INTERNAL SETUP

Image from –

[http://www.cnf.cornell.edu/cnf\\_spie1.html](http://www.cnf.cornell.edu/cnf_spie1.html)

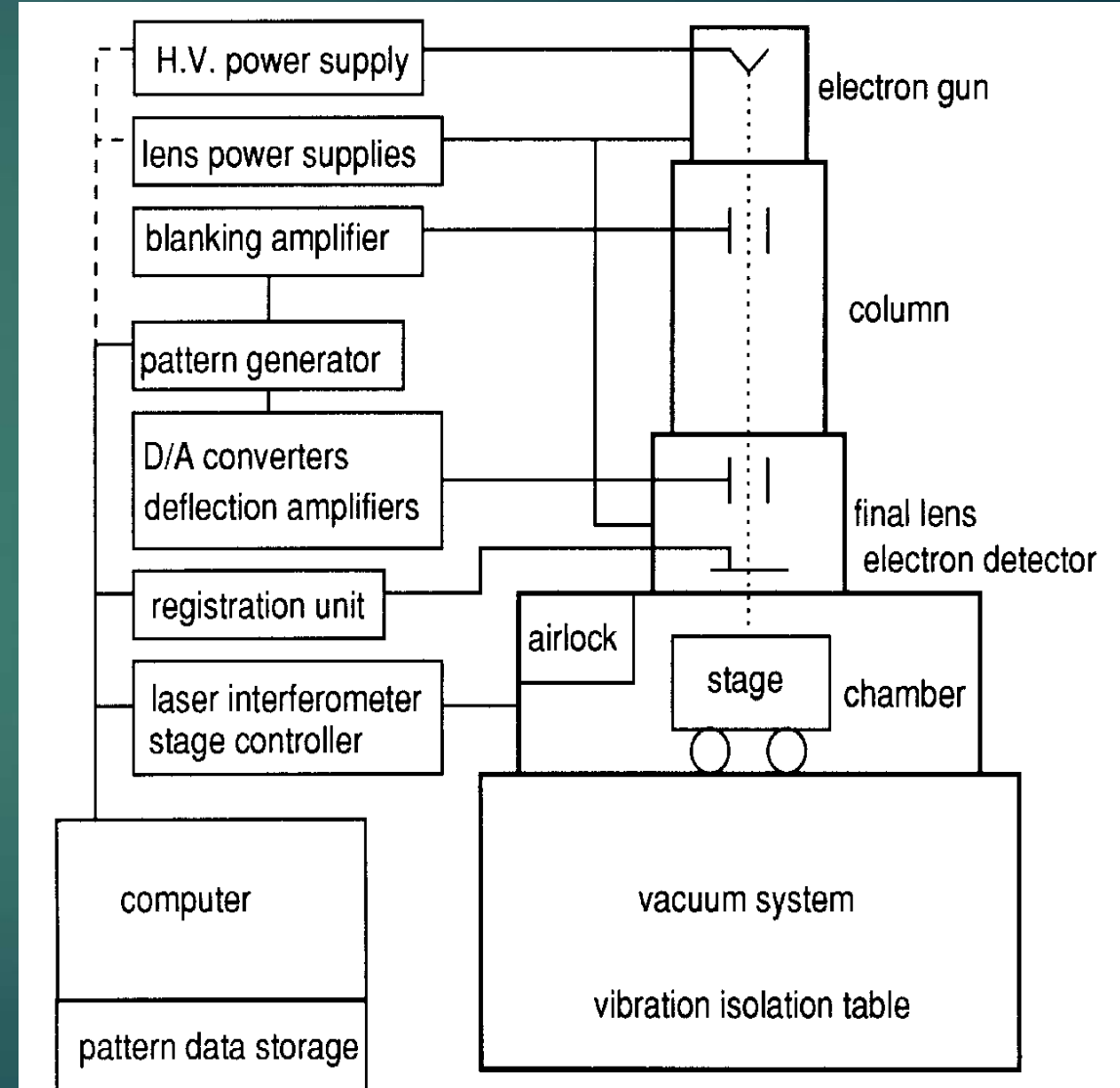

# CONSTRUCTION

A typical EBL system consists of the following parts –

- ▶ Electron source
- ▶ Electron column for shaping & focussing the beam
- ▶ A mechanical stage that positions the wafer under the electron beam
- ▶ A wafer handling system for automatically feeding & unloading the wafer
- ▶ A computer system for controlling the equipment.
- ▶ Additionally, a vacuum system is needed to maintain the appropriate vacuum level throughout, while a set of control electronics supplies power & signals to the various parts of the machine.



# A COMMERCIAL EBL SYSTEM

Image reference from –

<http://www.cnf.cornell.edu/image/spiefig2.jpg>

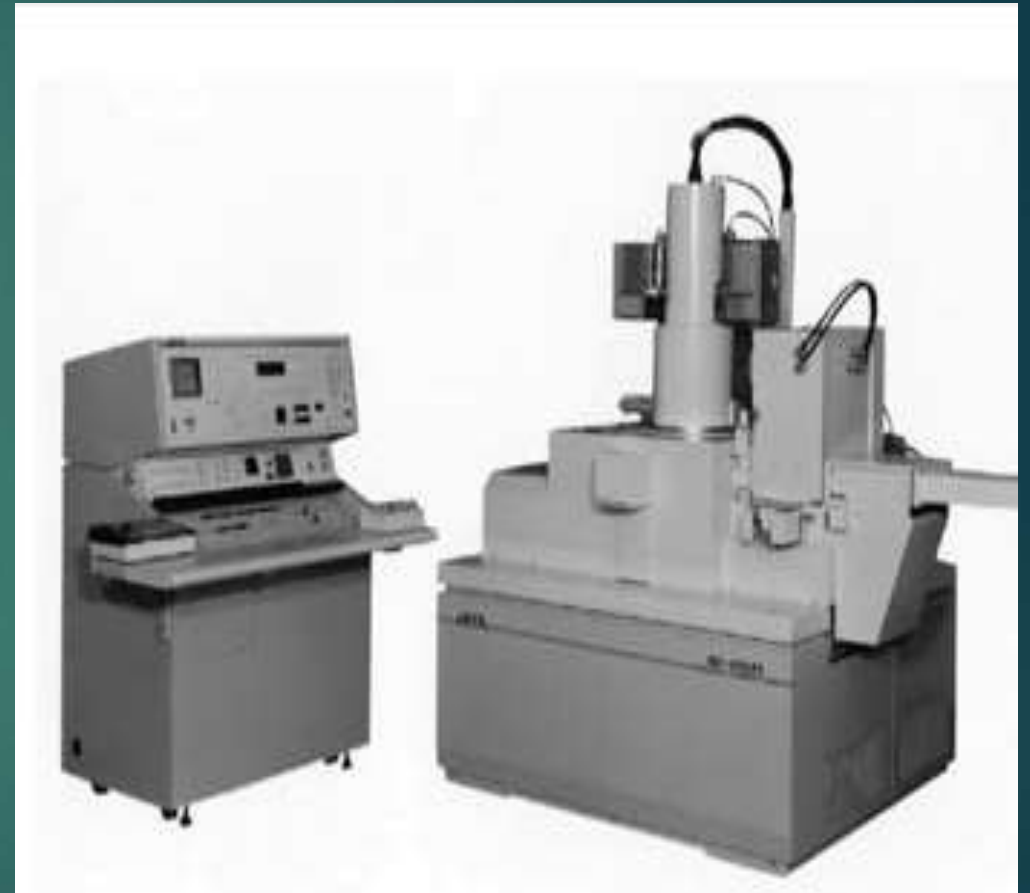
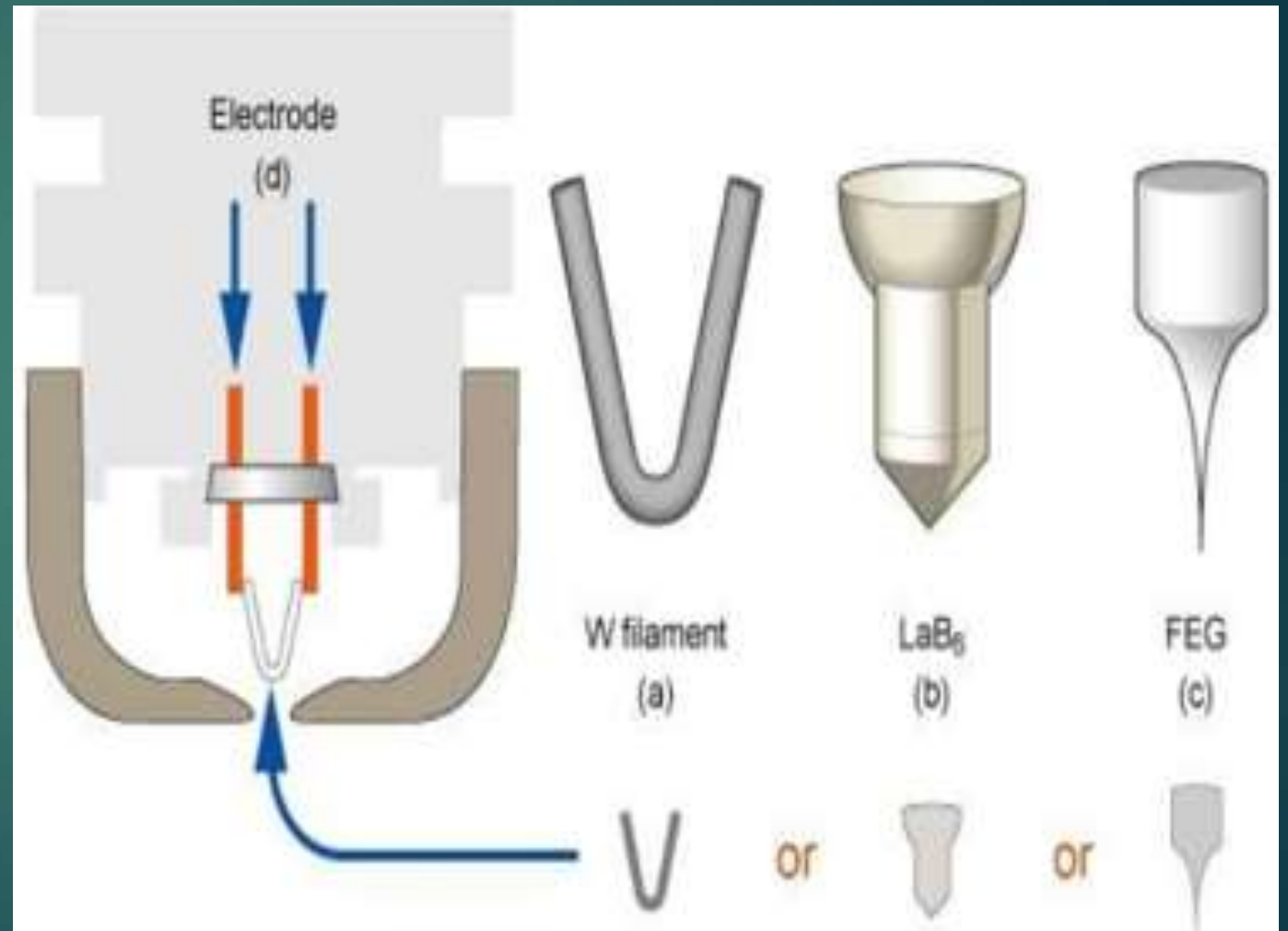

FIGURE 2.2. A commercial electron beam lithography tool.

# WORKING OF EBL SYSTEM

- ▶ The source of the beam is the electron gun, positioned at the top of the column.
- ▶ There are two basic types of electron guns: thermionic (lower resolution) and field emission (higher resolution).



# WORKING OF THE EBL SYSTEM

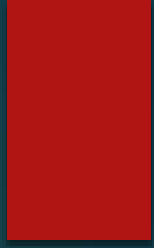

- ▶ A thermionic source is a heated wire from which electrons are given thermal energy to overcome the work function of the source, combined with an electric potential to give the newly free electrons direction and velocity.
- ▶ A field emission gun consists of a sharply pointed tungsten tip held at several kV negative potential relative to a nearby electrode, so that there is a very high potential gradient at the tungsten tip.
- ▶ The electron beam is then focused with several magnetic lenses and finally the beam hits the sample.

# BEAM SAMPLE INTERACTION

- ▶ Secondary electrons: low energy electrons emitted from the sample due to passage of beam electrons.
- ▶ Backscattered electrons: Back scattered electrons are primary beam electrons that have undergone collisions within the sample and have bounced around to re-emerge from the surface they came in.
- ▶ X-rays
- ▶ Cathodoluminescence

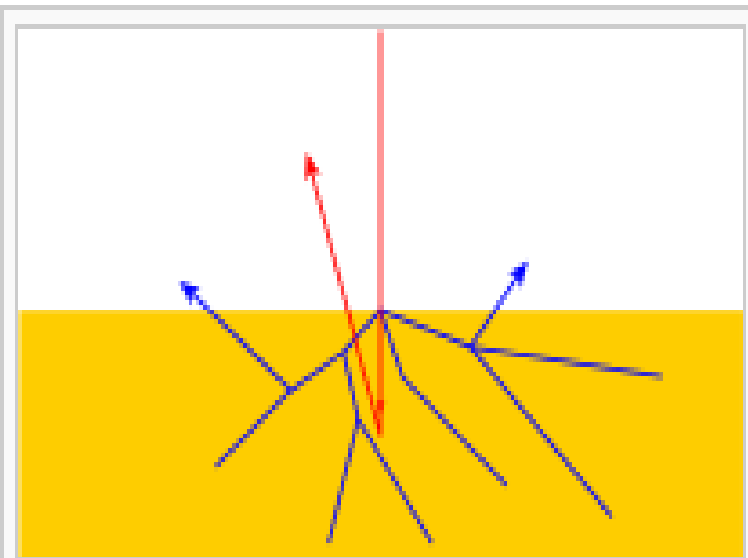

**Electron trajectories in resist:**   
An incident electron (red) produces secondary electrons (blue). Sometimes, the incident electron may itself be backscattered as shown here and leave the surface of the resist (amber).

# PROCESS STEPS

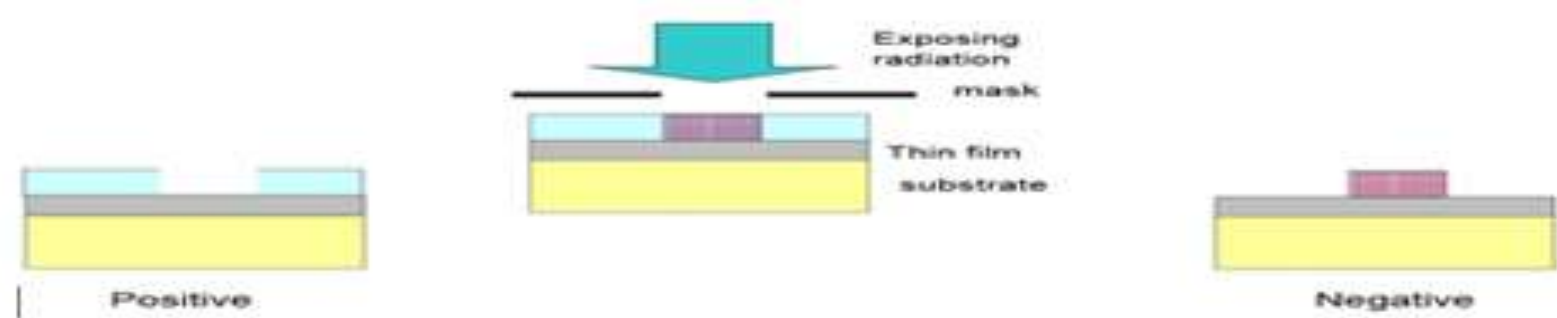

Figure 6- Types of Resist

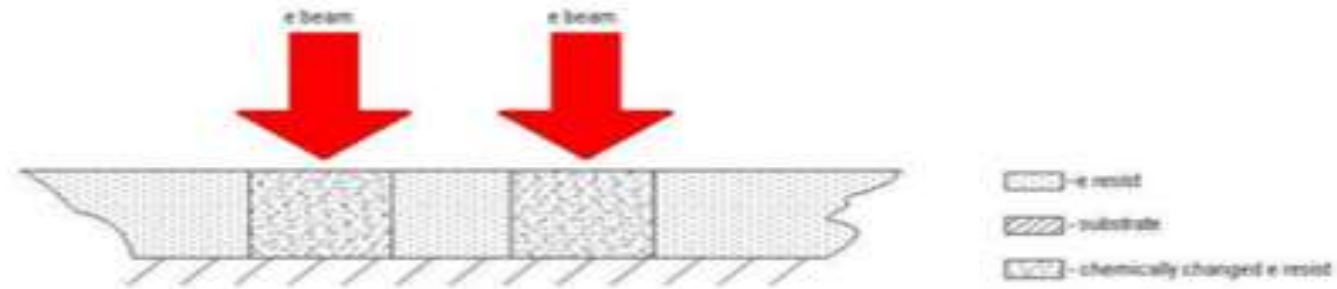

Figure 7 - Chemical changes in the exposed areas due to the electron beam



Figure 8 - Dissolution of the resist

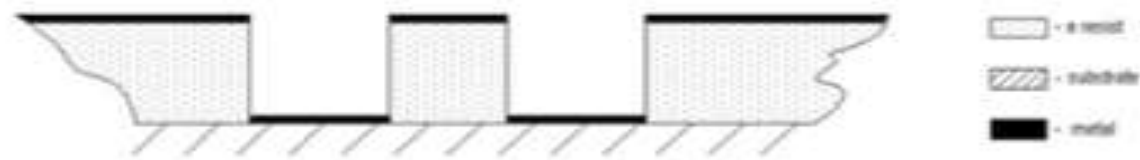

Figure 9 - Metal deposition



Figure 10 - Final Result

# RESISTS USED

- ▶ The most prevalent approach employs the exposure of resist materials which are most usually polymeric by energetic photons and particles.
- ▶ The exposed areas undergo structural or chemical modification such that they will have a differential solubility.

# TYPES OF RESIST

The first material developed for e-beam lithography was Polymethyl Methacrylate (PMMA), a positive resist with -

- ▶ Highest resolution
- ▶ No shelf life issues, inexpensive.
- ▶ Moderate glass transition temperature
- ▶ Other positive resists used are Toray EBR-9, ZEP series

NEB-31 - negative e-beam resist

- ▶ Sensitive to white light
- ▶ High contrast
- ▶ Other negative E beam resists are Microposit SAL601



# SUBSTRATE SELECTION CRITERIA

- ▶ A substrate for electron beam lithography must satisfy different (contradictory) conditions: it should be relatively conductive (in the opposite case the wafer would build up an electric charge, which would deflect the electron beam and thus distort the drawn pattern), on the other hand the base for electronic circuits should obviously be insulating (otherwise the entire circuit would be short circuited).
- ▶ Apparently a compromise must be made; the substrate should be as close to insulating as possible without distorting the drawn pattern.
- ▶ The most widely used substrate is silicon with a thin insulating layer of silicon dioxide on top or glass plates coated with metal where it should be grounded before drawing.



# COMPARISON TABLE

<b>ADVANTAGES</b>	<b>DISADVANTAGES</b>
<ul style="list-style-type: none"><li>• The resolution is not limited by diffraction.</li><li>• Can write smaller features</li><li>• Used to develop specialized devices</li><li>• Fast turn-around time</li><li>• No need of a physical mask</li><li>• Lower deflection densities</li><li>• Larger depth of focus due to continuous focussing</li></ul>	<ul style="list-style-type: none"><li>• Inefficient process for industrial processing</li><li>• Long time to pattern entire wafer</li><li>• High system cost</li><li>• System complexity due to requirement of vacuum</li><li>• Scattering and over exposure result in minimum feature being larger</li><li>• Slow throughput</li></ul>

# OTHER LITHOGRAPHY TECHNIQUES

- ▶ **X-ray lithography** can be extended to an optical resolution of 15 nm by using the short wavelengths of 1 nm for the illumination. The method is simple because it requires no lenses.
- ▶ **Double patterning** is a method of increasing the pitch resolution of a lithographic process by printing new features in between pre-printed features on the same layer. It is flexible because it can be adapted for any exposure or patterning technique. The feature size is reduced by non-lithographic techniques such as etching or sidewall spacers.
- ▶ **Extreme ultraviolet lithography** is a form of optical lithography using ultrashort wavelengths (13.5 nm).
- ▶ **Laser Printing of Single Nanoparticles** is a method where optical forces induced via scattering and absorption of photons on nanoparticles are used to direct single nanoparticles to specific locations on substrates and attach them via van-der Waals forces.
- ▶ **Neutral Particle Lithography** uses a broad beam of energetic neutral particle for pattern transfer on a surface.
- ▶ **Nanoimprint lithography** and its variants can be combined with contact printing and cold welding.

# OTHER LITHOGRAPHY TECHNIQUES

- ▶ **Charged-particle lithography**, such as ion or electron-projection lithographies (PREVAIL, SCALPEL), are capable of very-high-resolution patterning. Ion beam lithography uses a focused or broad beam of energetic lightweight ions (like  $\text{He}^+$ ) for transferring pattern to a surface.
- ▶ **Scanning probe lithography** is a tool for patterning at the deep nanometer-scale by manipulating individual atoms using the tip of a scanning tunneling microscope (STM).
- ▶ **Atomic Force Microscopic Nanolithography** is a chemomechanical surface patterning technique that uses an atomic force microscope.
- ▶ **Thermochemical Nanolithography** is an atomic force microscopy based technique, which uses hot tips to activate chemical reactions at the nanoscale.
- ▶ **Magnetolithography** is based on applying a magnetic field on the substrate using paramagnetic metal masks, which define the spatial distribution and shape of the applied magnetic field. The second component is ferromagnetic nanoparticles that are assembled onto the substrate according to the field induced by the magnetic mask.

# REFERENCES FROM -

- ▶ Nanolithography, Gunasekaran Venugopal and Sang-Jae Kim, <http://dx.doi.org/10.5772/55527>
- ▶ Introduction to Electron Beam Lithography
- ▶ Boštjan Berčič , Jožef Štefan Institute, Slovenia
- ▶ <http://Wikipedia.org>

THANK YOU !!!