

# ELECTRONIC DEVICES AND CIRCUIT THEORY

TENTH EDITION

BOYLESTAD

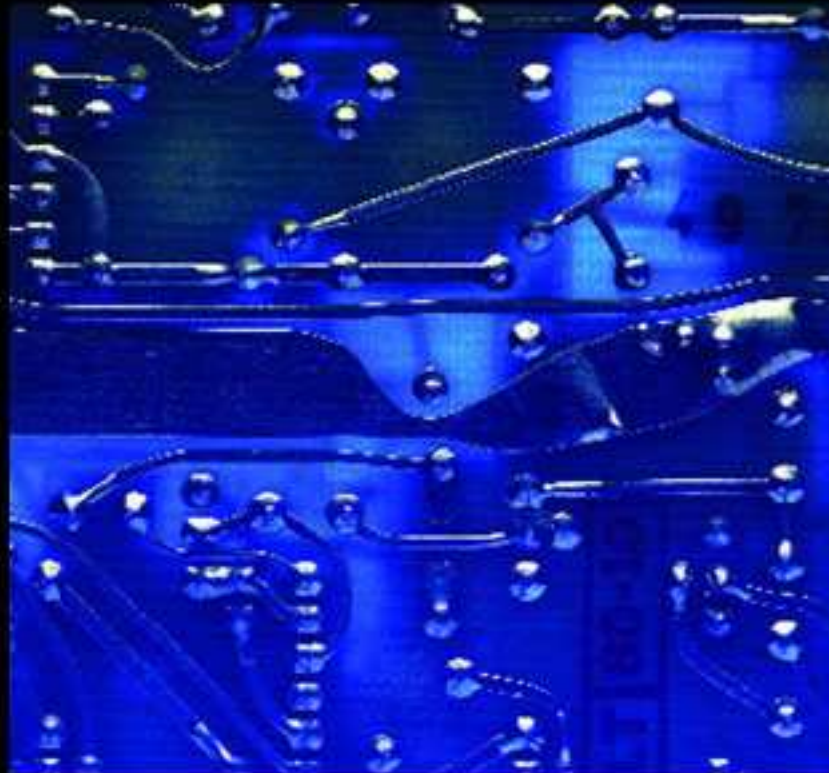

PEARSON

## Chapter 10: Operational Amplifiers

# Basic Op-Amp

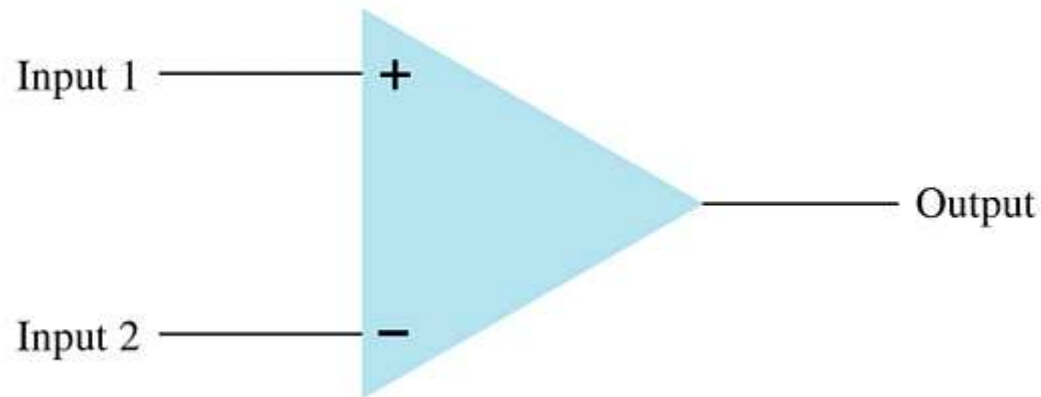

**Operational amplifier or op-amp, is a very high gain differential amplifier with a high input impedance (typically a few meg-Ohms) and low output impedance (less than 100  $\Omega$ ).**

**Note the op-amp has two inputs and one output.**

# Op-Amp Gain

**Op-Amps have a very high gain. They can be connected open-loop or closed-loop.**

- **Open-loop** refers to a configuration where there is no feedback from output back to the input. In the open-loop configuration the gain can exceed 10,000.
- **Closed-loop** configuration reduces the gain. In order to control the gain of an op-amp it must have feedback. This feedback is a negative feedback. A **negative feedback** reduces the gain and improves many characteristics of the op-amp.

# Inverting Op-Amp

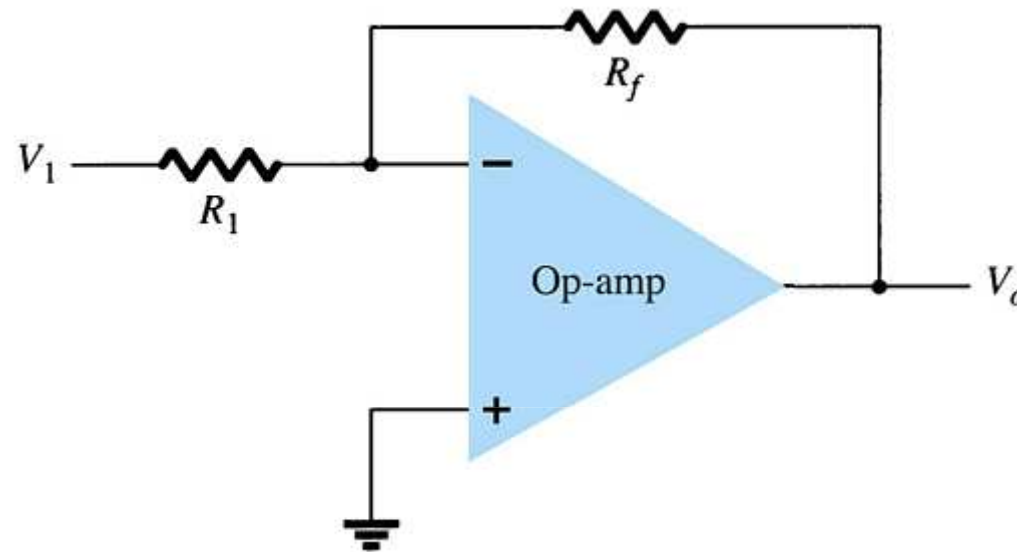

- The signal input is applied to the **inverting (-) input**
- The **non-inverting input (+)** is grounded
- The resistor  $R_f$  is the **feedback resistor**. It is connected from the output to the negative (inverting) input. This is **negative feedback**.

# Inverting Op-Amp Gain

Gain can be determined from external resistors:  $R_f$  and  $R_1$

$$A_v = \frac{V_o}{V_i} = \frac{R_f}{R_1}$$

Unity gain—voltage gain is 1

$$R_f = R_1$$

$$A_v = \frac{-R_f}{R_1} = -1$$

The negative sign denotes a 180° phase shift between input and output.

Constant Gain— $R_f$  is a multiple of  $R_1$

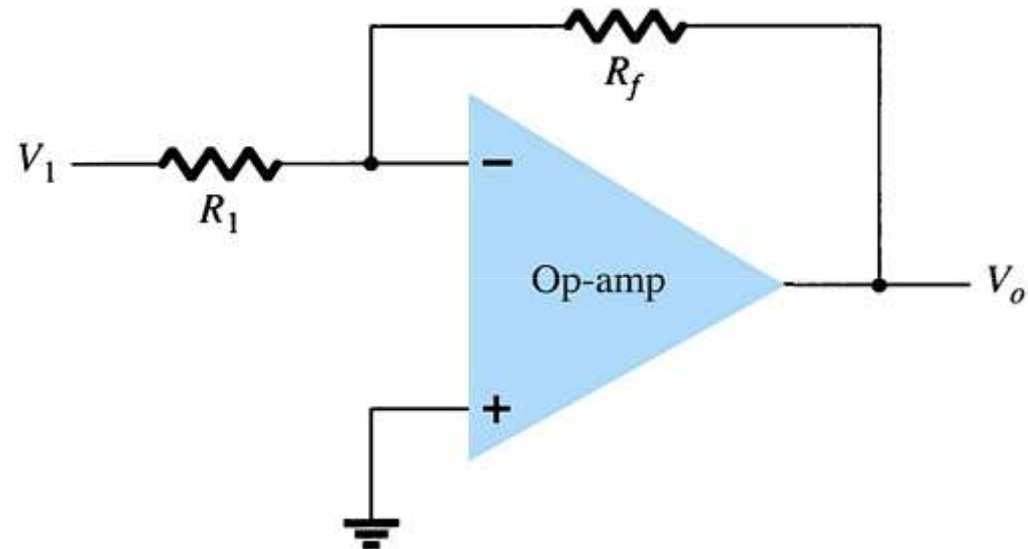

# Virtual Ground

An understanding of the concept of **virtual ground** provides a better understanding of how an op-amp operates.

The *non-inverting* input pin is at ground. The *inverting* input pin is also at 0 V for an AC signal.

The op-amp has such high input impedance that even with a high gain there is no current from inverting input pin, therefore there is no voltage from inverting pin to ground—all of the current is through  $R_f$ .

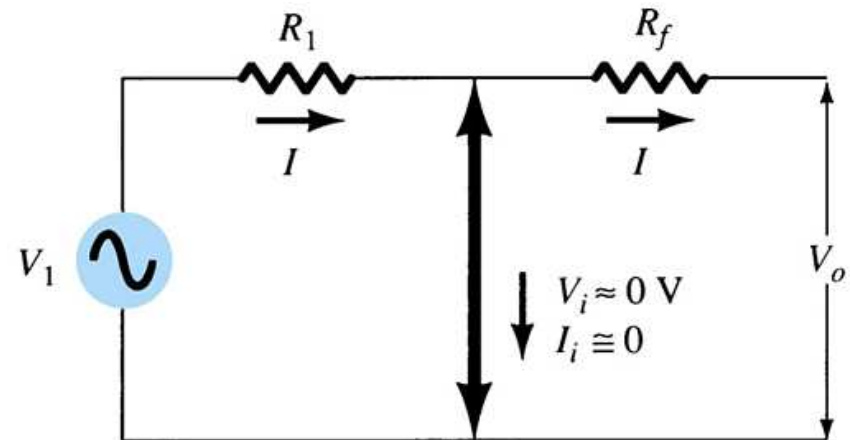
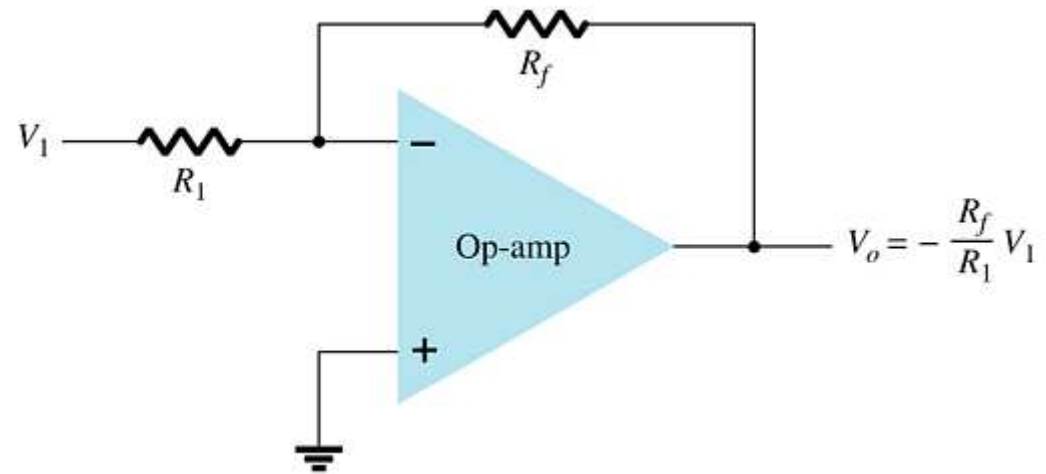

# Practical Op–Amp Circuits

Inverting amplifier  
Noninverting amplifier  
Unity follower  
Summing amplifier  
Integrator  
Differentiator

# Inverting/Noninverting Op-Amps

## Inverting Amplifier

$$V_o = \frac{-R_f}{R_1} V_1$$

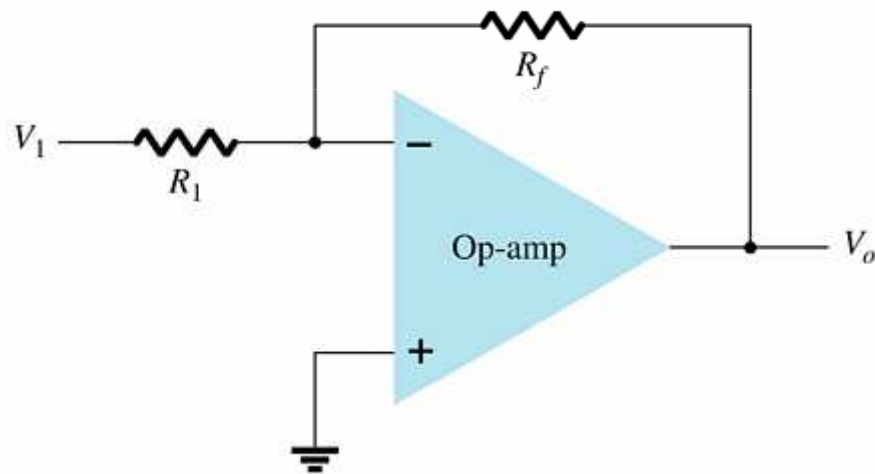

## Noninverting Amplifier

$$V_o = \left(1 + \frac{R_f}{R_1}\right) V_1$$

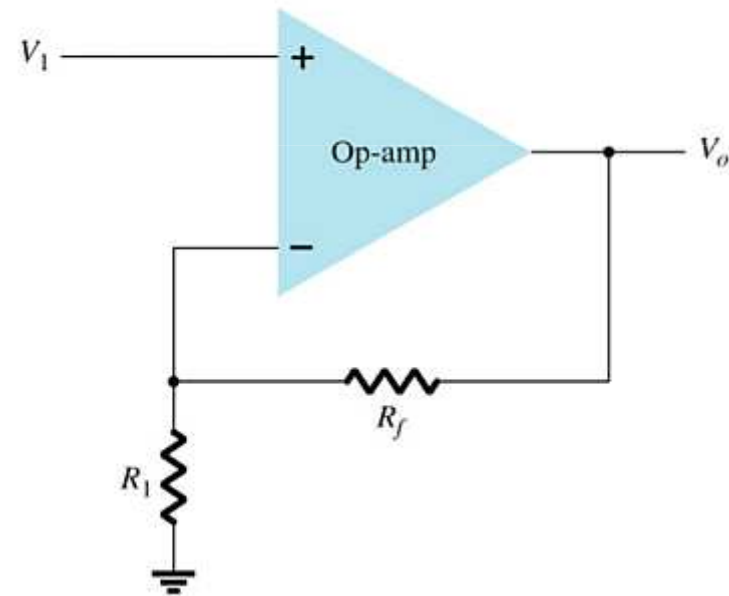



# Unity Follower

$$V_o = V_1$$

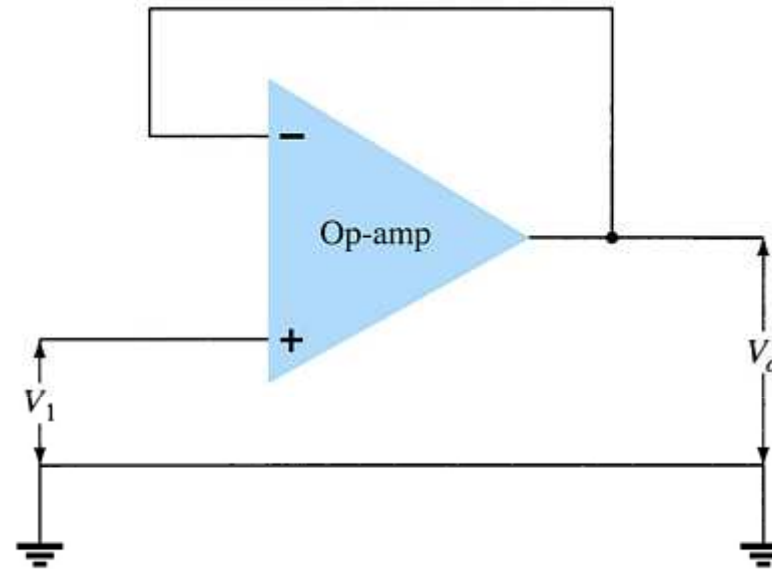

# Summing Amplifier

Because the op-amp has a high input impedance, the multiple inputs are treated as separate inputs.

$$V_o = -\left(\frac{R_f}{R_1} V_1 + \frac{R_f}{R_2} V_2 + \frac{R_f}{R_3} V_3\right)$$

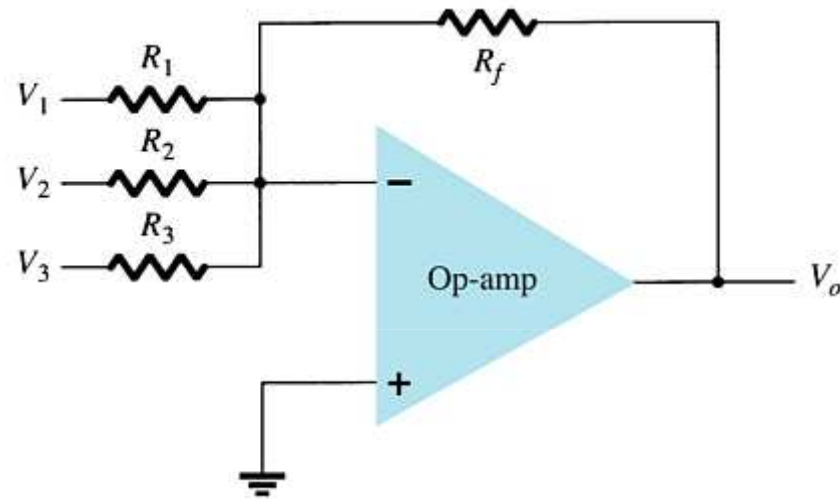

# Integrator

The output is the integral of the input. Integration is the operation of summing the area under a waveform or curve over a period of time. This circuit is useful in low-pass filter circuits and sensor conditioning circuits.

$$v_o(t) = -\frac{1}{RC} \int v_1(t) dt$$

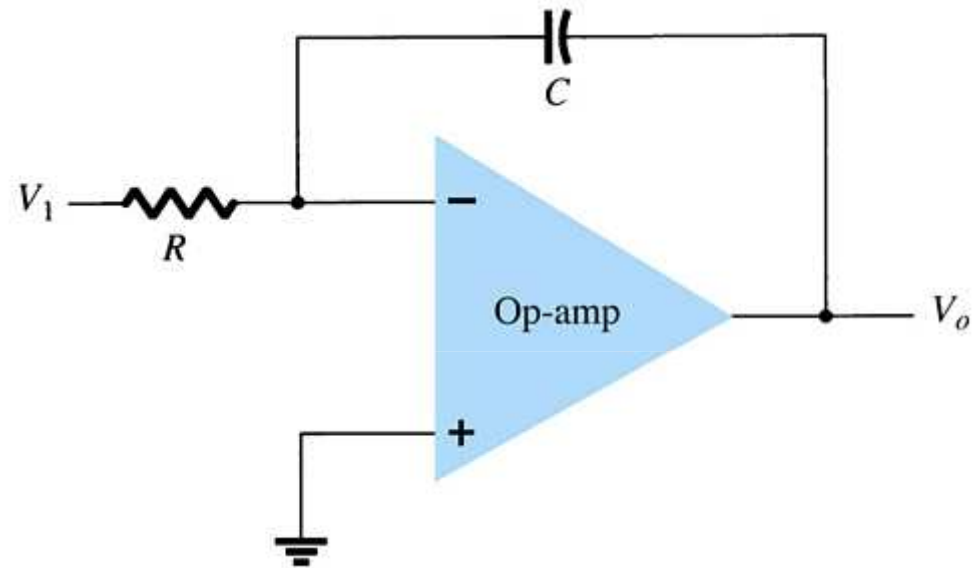

# Differentiator

The differentiator takes the derivative of the input. This circuit is useful in high-pass filter circuits.

$$v_o(t) = -RC \frac{dv_1(t)}{dt}$$

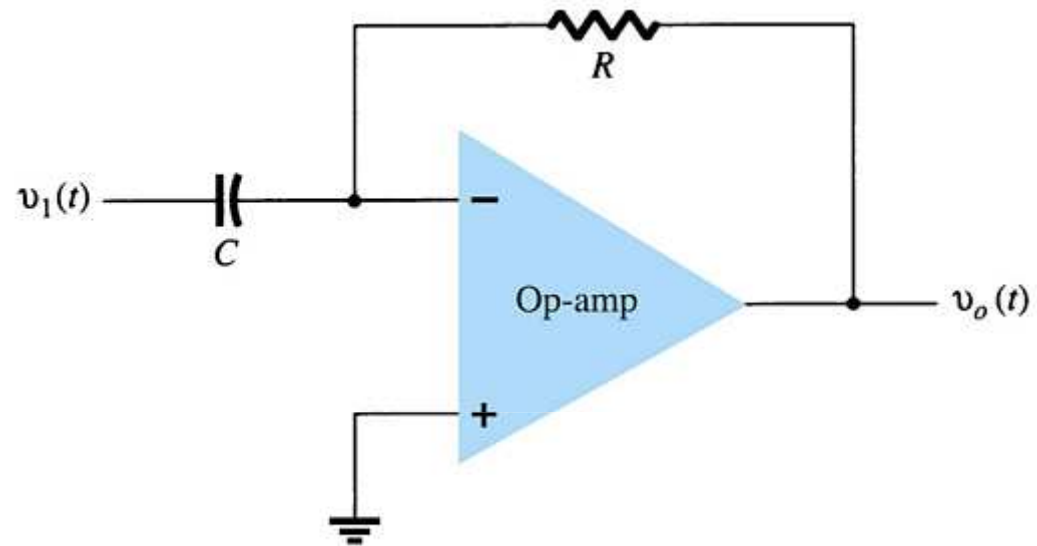

# Op-Amp Specifications—DC Offset Parameters

**Even when the input voltage is zero, there can be an output **offset**. The following can cause this offset:**

- Input offset voltage
- Input offset current
- Input offset voltage *and* input offset current
- Input bias current

# Input Offset Voltage ( $V_{IO}$ )

The specification sheet for an op-amp indicate an input offset voltage ( $V_{IO}$ ).

The effect of this input offset voltage on the output can be calculated with

$$V_{o(\text{offset})} = V_{IO} \frac{R_1 + R_f}{R_1}$$

# Output Offset Voltage Due to Input Offset Current ( $I_{IO}$ )

**If there is a difference between the dc bias currents for the same applied input, then this also causes an output offset voltage:**

- The input offset Current ( $I_{IO}$ ) is specified in the specifications for the op-amp.
- The effect on the output can be calculated using:

$$V_{o(\text{offset due to } I_{IO})} = I_{IO} R_f$$

# Total Offset Due to $V_{IO}$ and $I_{IO}$

**Op-amps may have an output offset voltage due to both factors  $V_{IO}$  and  $I_{IO}$ . The total output offset voltage will be the sum of the effects of both:**

$$V_o(\text{offset}) = V_o(\text{offset due to } V_{IO}) + V_o(\text{offset due to } I_{IO})$$



# Input Bias Current ( $I_{IB}$ )

A parameter that is related to input offset current ( $I_{IO}$ ) is called **input bias current** ( $I_{IB}$ )

The separate input bias currents are:

$$I_{IB}^- = I_{IB} - \frac{I_{IO}}{2} \qquad I_{IB}^+ = I_{IB} + \frac{I_{IO}}{2}$$

The total input bias current is the average:

$$I_{IB} = \frac{I_{IB}^- + I_{IB}^+}{2}$$

# Frequency Parameters

**An op-amp is a wide-bandwidth amplifier. The following affect the bandwidth of the op-amp:**

- **Gain**
- **Slew rate**

# Gain and Bandwidth

The op-amp's high frequency response is limited by internal circuitry. The plot shown is for an open loop gain ( $A_{OL}$  or  $A_{VD}$ ). This means that the op-amp is operating at the highest possible gain with no feedback resistor.

In the open loop, the op-amp has a narrow bandwidth. The bandwidth widens in closed-loop operation, but then the gain is lower.

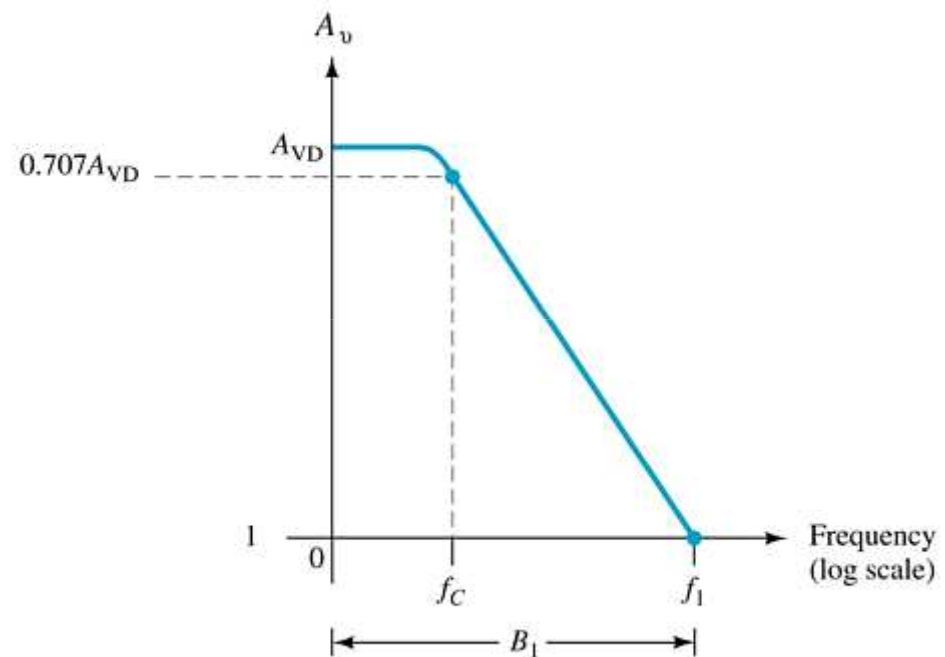

# Slew Rate (SR)

**Slew rate (SR)** is the maximum rate at which an op-amp can change output without distortion.

$$\text{SR} = \frac{\Delta V_o}{\Delta t} \quad (\text{in } V/\mu\text{s})$$

The SR rating is given in the specification sheets as V/μs rating.

# Maximum Signal Frequency

**The slew rate determines the highest frequency of the op-amp without distortion.**

$$f \leq \frac{SR}{2\pi V_p}$$

**where  $V_p$  is the peak voltage**

# General Op–Amp Specifications

**Other ratings for op-amp found on specification sheets are:**

- **Absolute Ratings**
- **Electrical Characteristics**
- **Performance**

# Absolute Ratings

**These are common maximum ratings for the op-amp.**

Absolute Maximum Ratings	
Supply voltage	6.22 V
Internal power dissipation	500 mW
Differential input voltage	6.30 V
Input voltage	6.15 V

# Electrical Characteristics

**TABLE 13.2** mA741 Electrical Characteristics:  $V_{CC} = \pm 15 \text{ V}$ ,  $T_A = 25^\circ\text{C}$

Characteristic	MIN	TYP	MAX	Unit
$V_{IO}$ Input offset voltage		1	6	mV
$I_{IO}$ Input offset current		20	200	nA
$I_{IB}$ Input bias current		80	500	nA
$V_{ICR}$ Common-mode input voltage range	$\pm 12$	$\pm 13$		V
$V_{OM}$ Maximum peak output voltage swing	$\pm 12$	$\pm 14$		V
$A_{VD}$ Large-signal differential voltage amplification	20	200		V/mV
$r_i$ Input resistance	0.3	2		M $\Omega$
$r_o$ Output resistance		75		$\Omega$
$C_i$ Input capacitance		1.4		pF
CMRR Common-mode rejection ratio	70	90		dB
$I_{CC}$ Supply current		1.7	2.8	mA
$P_D$ Total power dissipation		50	85	mW

**Note:** These ratings are for specific circuit conditions, and they often include minimum, maximum and typical values.



# CMRR

**One rating that is unique to op-amps is CMRR or **common-mode rejection ratio**.**

**Because the op-amp has two inputs that are opposite in phase (inverting input and the non-inverting input) any signal that is common to both inputs will be cancelled.**

**Op-amp CMRR is a measure of the ability to cancel out common-mode signals.**

# Op-Amp Performance

The specification sheets will also include graphs that indicate the performance of the op-amp over a wide range of conditions.

