

# ELECTRONIC DEVICES AND CIRCUIT THEORY

TENTH EDITION

BOYLESTAD



PEARSON

## Chapter 11 Op-Amp Applications

# Op-Amp Applications

**Constant-gain multiplier**  
**Voltage summing**  
**Voltage buffer**  
**Controlled sources**  
**Instrumentation circuits**  
**Active filters**

# Constant-Gain Amplifier

## Inverting Version

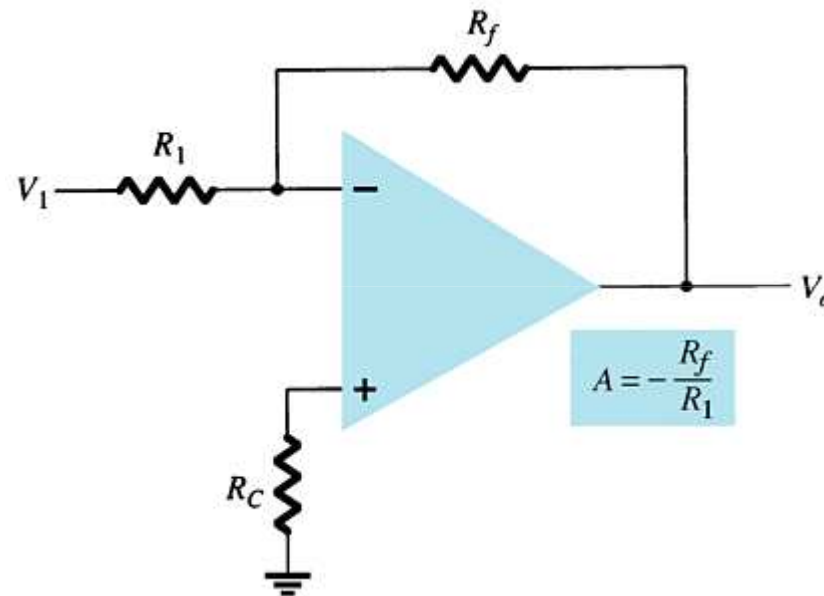

[more...](#)

# Constant-Gain Amplifier

## Noninverting Version

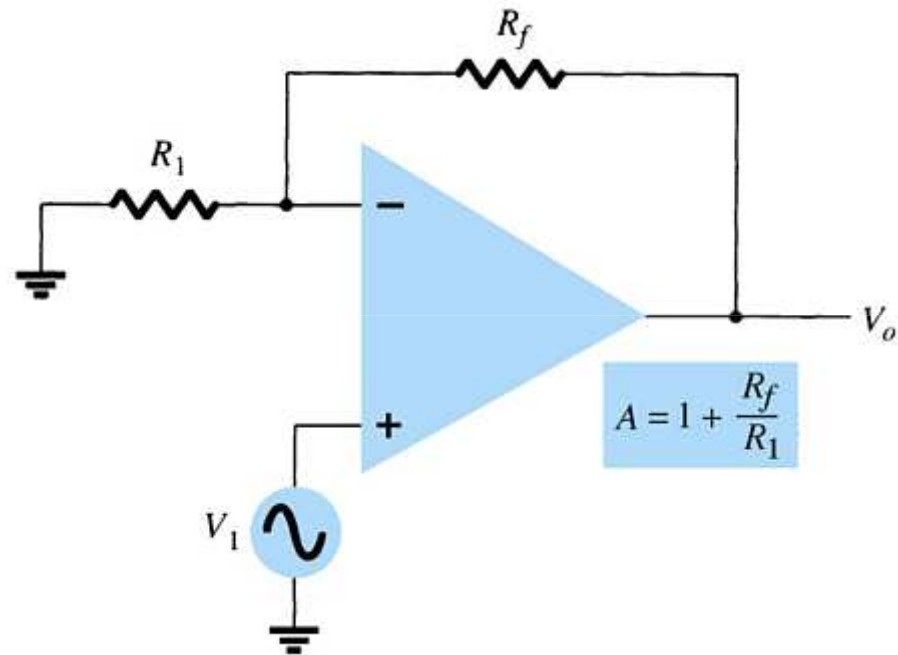

# Multiple-Stage Gains

The total gain (3-stages) is given by:

$$\mathbf{A} = \mathbf{A}_1 \mathbf{A}_2 \mathbf{A}_3$$

or

$$\mathbf{A} = \left( \mathbf{1} + \frac{\mathbf{R}_f}{\mathbf{R}_1} \right) \left( -\frac{\mathbf{R}_f}{\mathbf{R}_2} \right) \left( -\frac{\mathbf{R}_f}{\mathbf{R}_3} \right)$$

# Voltage Summing

The output is the sum of individual signals times the gain:

$$V_o = -\left(\frac{R_f}{R_1} V_1 + \frac{R_f}{R_2} V_2 + \frac{R_f}{R_3} V_3\right)$$

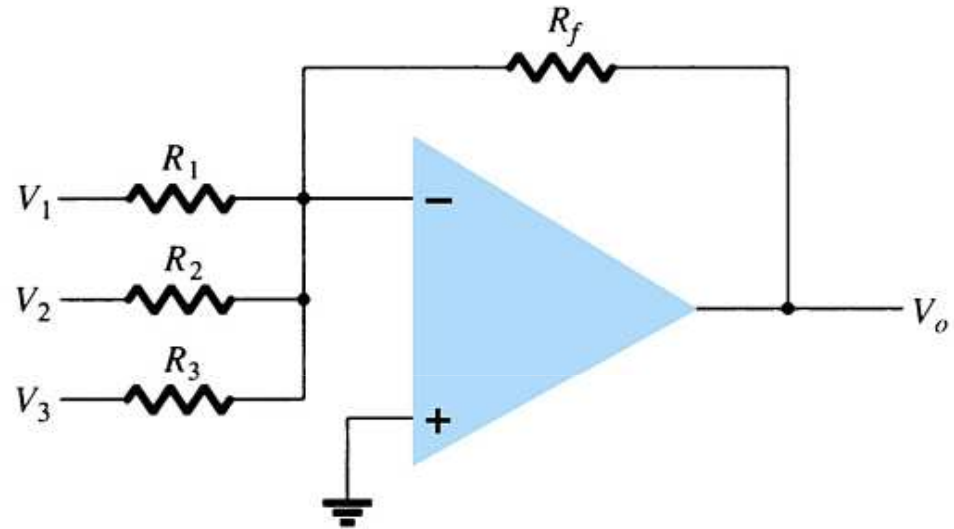

[Formula 14.3]

# Voltage Buffer

Any amplifier with no gain or loss is called a **unity gain amplifier**.

The advantages of using a unity gain amplifier:

- Very high input impedance
- Very low output impedance

Realistically these circuits are designed using equal resistors ( $R_1 = R_f$ ) to avoid problems with offset voltages.

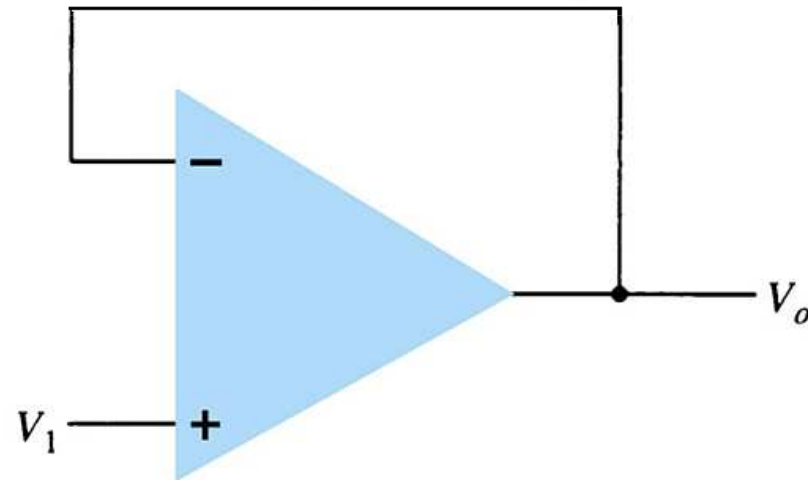

# Controlled Sources

**Voltage-controlled voltage source**  
**Voltage-controlled current source**  
**Current-controlled voltage source**  
**Current-controlled current source**



# Voltage-Controlled Voltage Source

The output voltage is the gain times the input voltage. What makes an op-amp different from other amplifiers is its impedance characteristics and gain calculations that depend solely on external resistors.

## Noninverting Amplifier Version

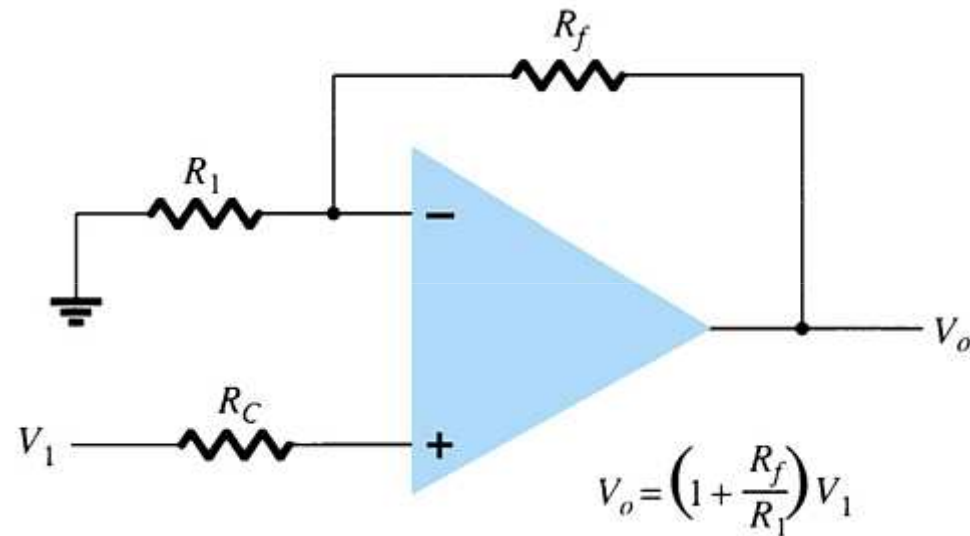

more...

# Voltage-Controlled Voltage Source

The output voltage is the gain times the input voltage. What makes an op-amp different from other amplifiers is its impedance characteristics and gain calculations that depend solely on external resistors.

## Inverting Amplifier Version

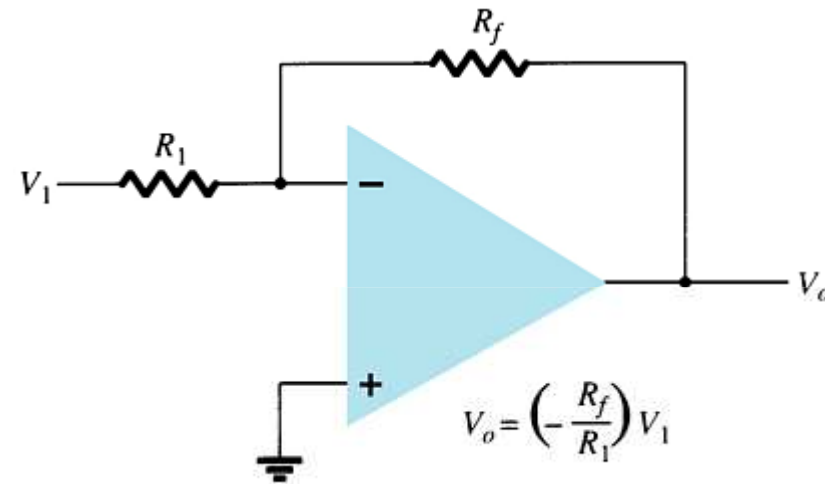

# Voltage-Controlled Current Source

The output current is:

$$I_o = \frac{V_1}{R_1} = kV_1$$

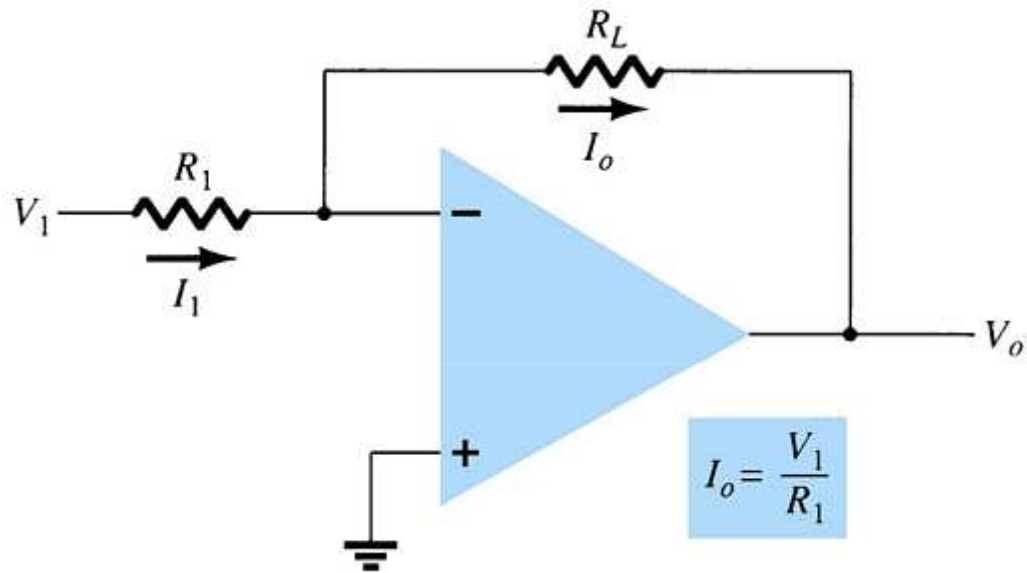

# Current-Controlled Voltage Source

This is simply another way of applying the op-amp operation. Whether the input is a current determined by  $V_{in}/R_1$  or as  $I_1$ :

$$V_{out} = \frac{-R_f}{R_1} V_{in}$$

or

$$V_{out} = -I_1 R_L$$

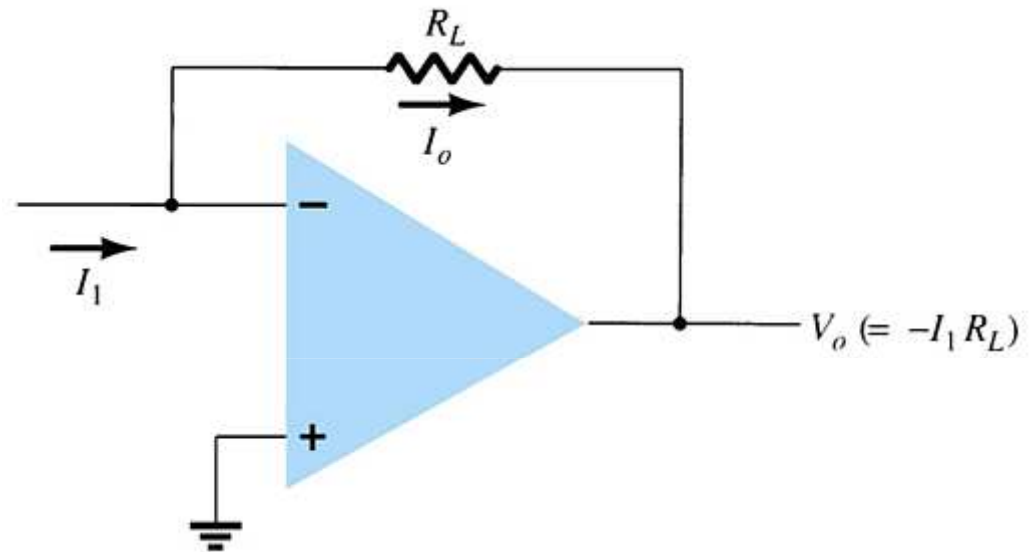

# Current-Controlled Current Source

This circuit may appear more complicated than the others but it is really the same thing.

$$V_{\text{out}} = -\left(\frac{R_f}{R_{\text{in}}}\right)V_{\text{in}}$$

$$I_o = -\frac{V_{\text{in}}}{R_1 \parallel R_2}$$

$$\frac{V_{\text{out}}}{R_f} = -\frac{V_{\text{in}}}{R_1 \parallel R_2}$$

$$I_o = -V_{\text{in}}\left(\frac{R_1 + R_2}{R_1 \times R_2}\right)$$

$$\frac{V_{\text{out}}}{R_f} = -\frac{V_{\text{in}}}{R_{\text{in}}}$$

$$I_o = -\frac{V_{\text{in}}}{R_1}\left(\frac{R_1 + R_2}{R_2}\right)$$

$$I_o = -I\left(1 + \frac{R_1}{R_2}\right) = kI$$

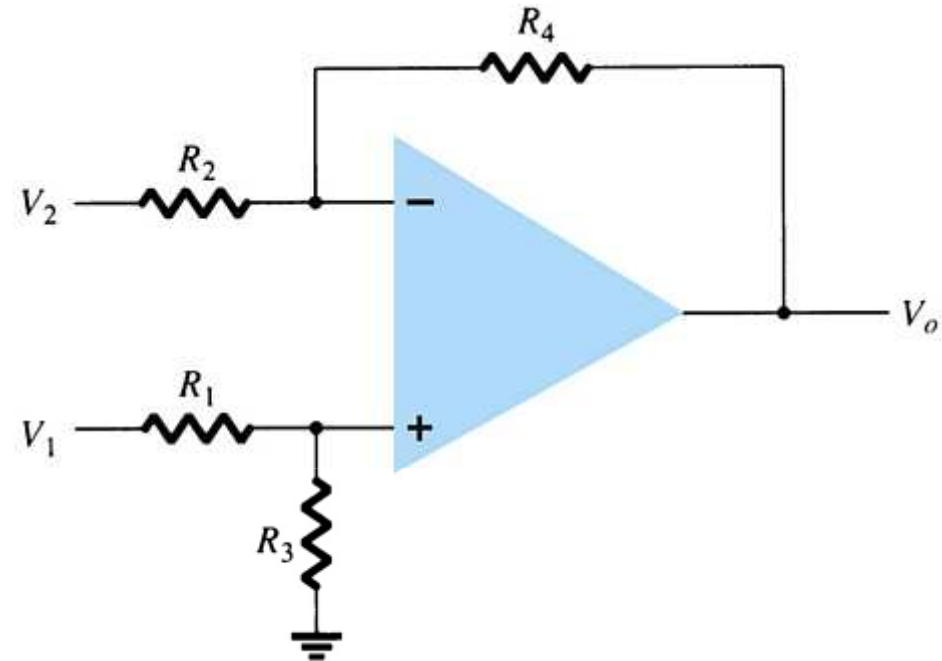

# Instrumentation Circuits

**Some examples of instrumentation circuits using op-amps:**

- **Display driver**
- **Instrumentation amplifier**

# Display Driver

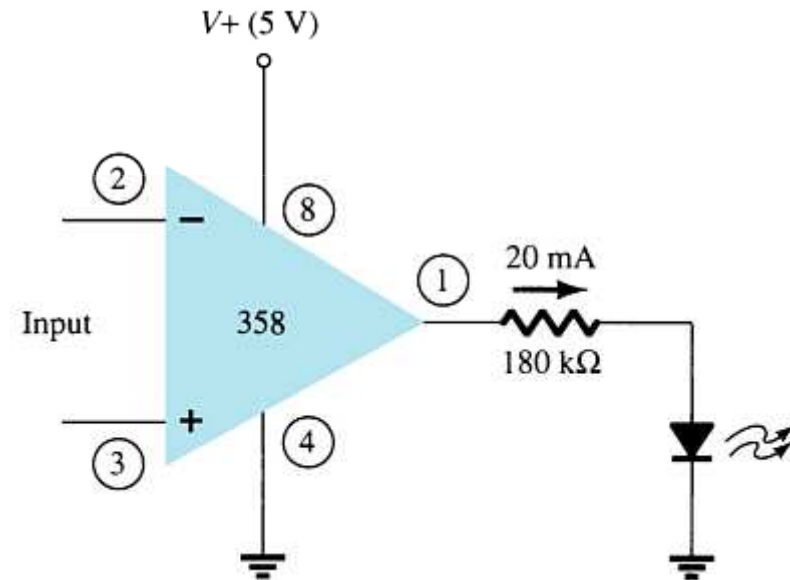
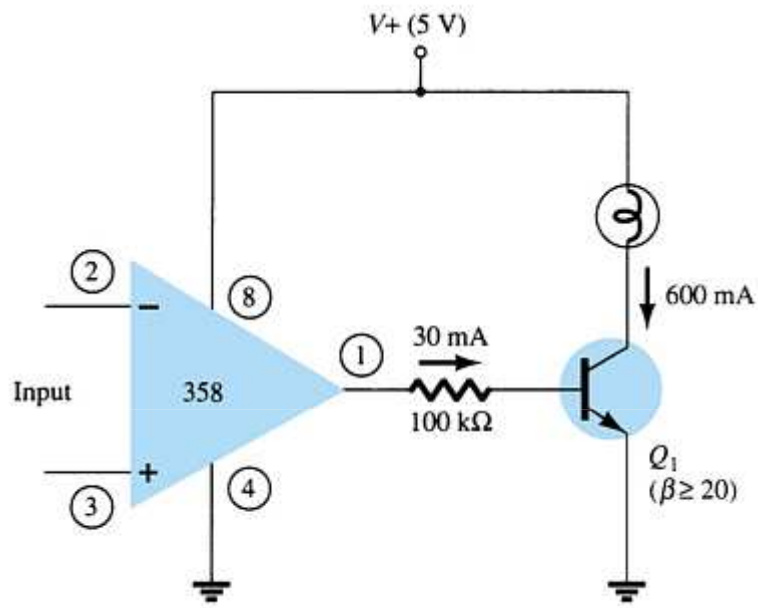

# Instrumentation Amplifier

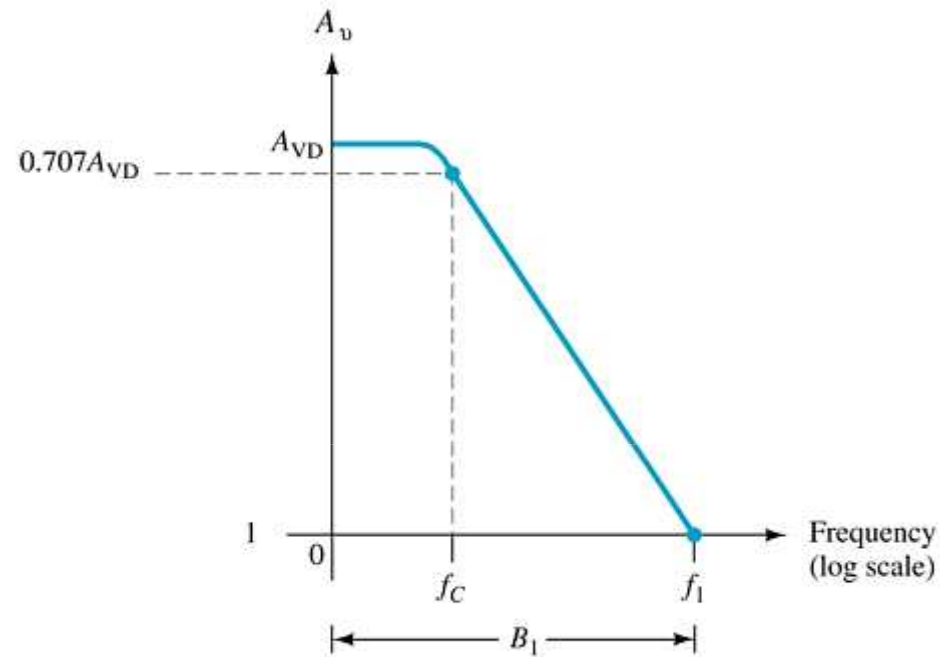

**For all  $R_s$  at the same value (except  $R_p$ ):**

$$V_o = \left( 1 + \frac{2R}{R_p} \right) (V_1 - V_2) = k(V_1 - V_2)$$



# Active Filters

**Adding capacitors to op-amp circuits provides external control of the cutoff frequencies. The op-amp active filter provides controllable cutoff frequencies and controllable gain.**

- **Low-pass filter**
- **High-pass filter**
- **Bandpass filter**

# Low-Pass Filter—First-Order

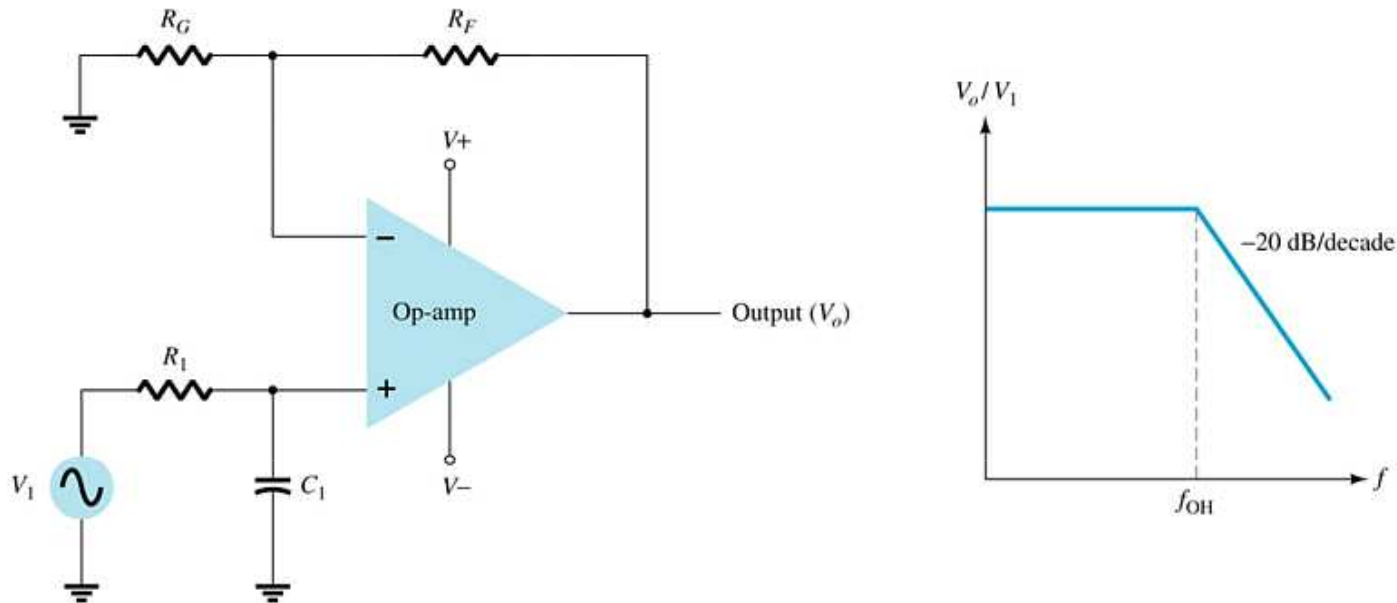

The upper cutoff frequency and voltage gain are given by:

$$f_{OH} = \frac{1}{2\pi R_1 C_1}$$

$$A_v = 1 + \frac{R_f}{R_1}$$

# Low-Pass Filter—Second-Order

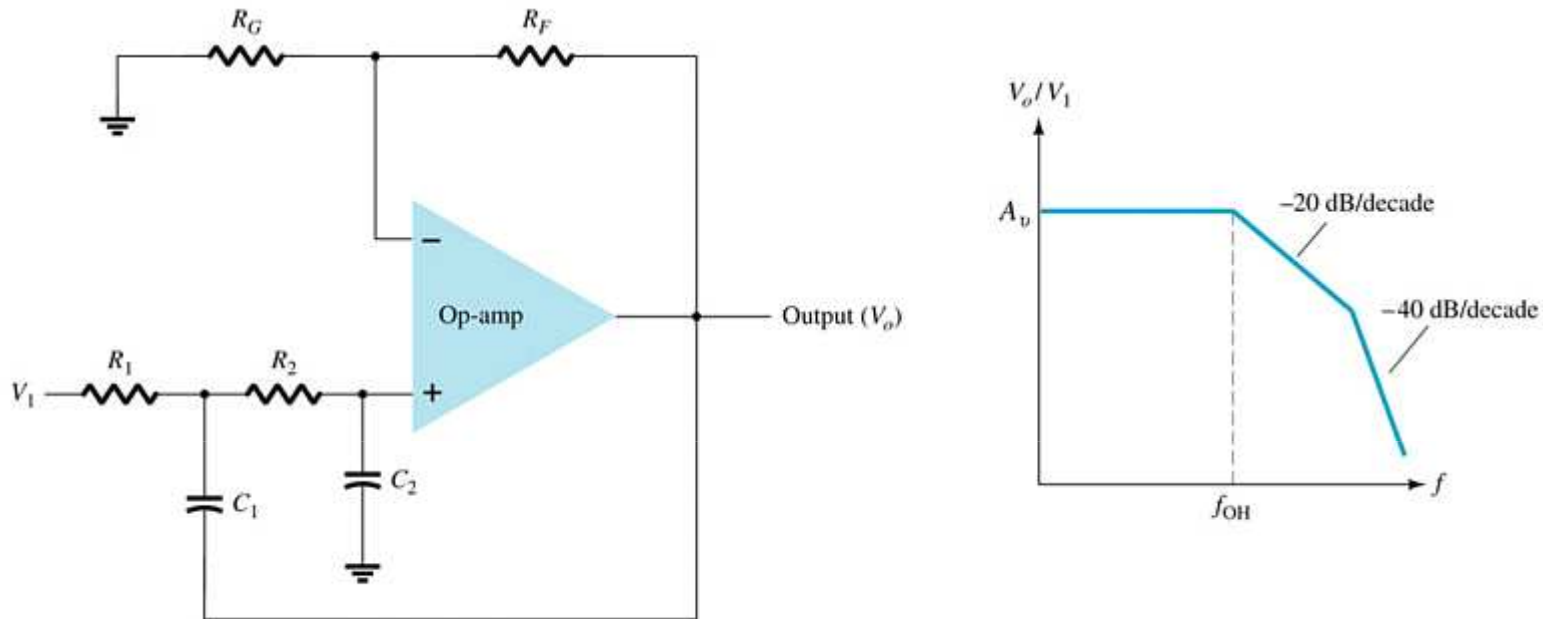

**The roll-off can be made steeper by adding more RC networks.**

# High-Pass Filter

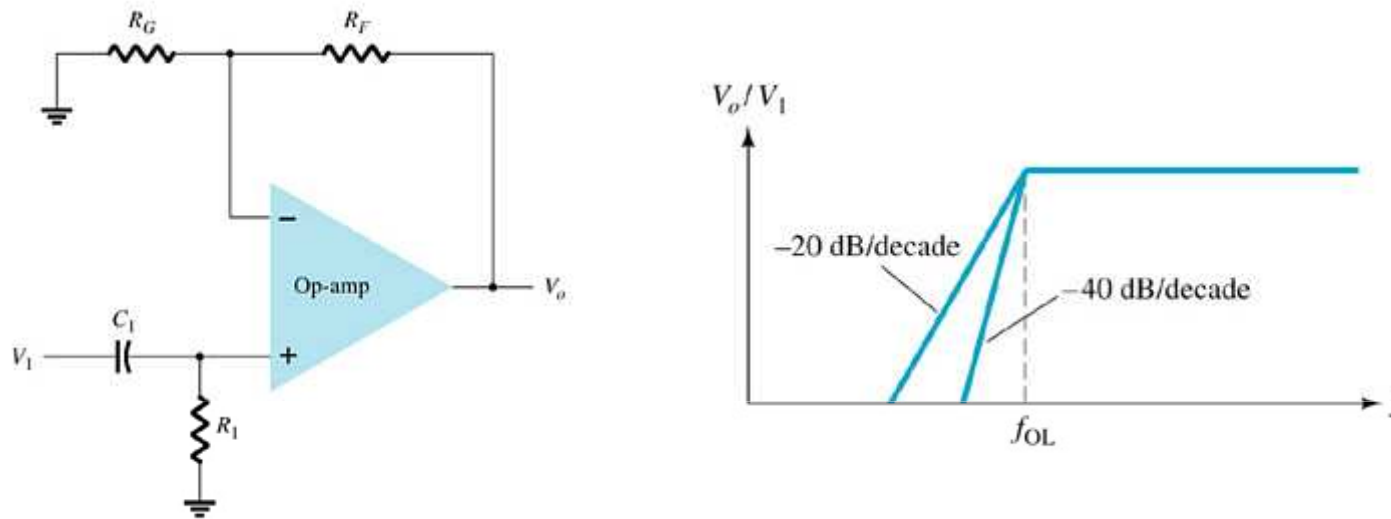

The cutoff frequency is determined by:

$$f_{OL} = \frac{1}{2\pi R_1 C_1}$$

# Bandpass Filter

There are two cutoff frequencies: upper and lower. They can be calculated using the same low-pass cutoff and high-pass cutoff frequency formulas in the appropriate sections.

