

ELECTRONIC DEVICES AND CIRCUIT THEORY

TENTH EDITION

BOYLESTAD



PEARSON

Chapter 2: Diode Applications

Load-Line Analysis

The load line plots all possible combinations of diode current (I_D) and voltage (V_D) for a given circuit. The maximum I_D equals E/R , and the maximum V_D equals E .

The point where the load line and the characteristic curve intersect is the Q-point, which identifies I_D and V_D for a particular diode in a given circuit.

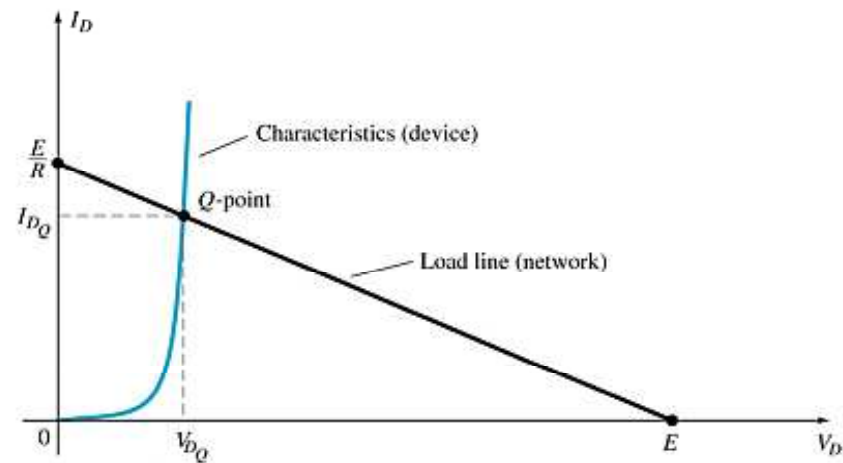

Series Diode Configurations

Forward Bias

Constants

- Silicon Diode: $V_D = 0.7 \text{ V}$
- Germanium Diode: $V_D = 0.3 \text{ V}$

Analysis (for silicon)

- $V_D = 0.7 \text{ V}$ (or $V_D = E$ if $E < 0.7 \text{ V}$)
- $V_R = E - V_D$
- $I_D = I_R = I_T = V_R / R$

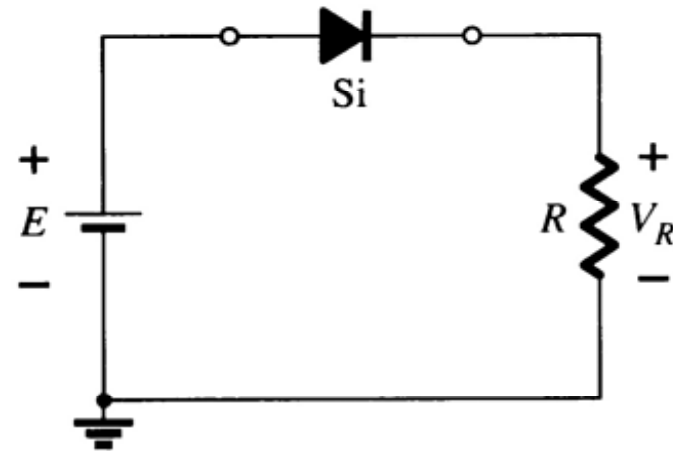

Series Diode Configurations

Reverse Bias

Diodes ideally behave as open circuits

Analysis

- $V_D = E$
- $V_R = 0 \text{ V}$
- $I_D = 0 \text{ A}$

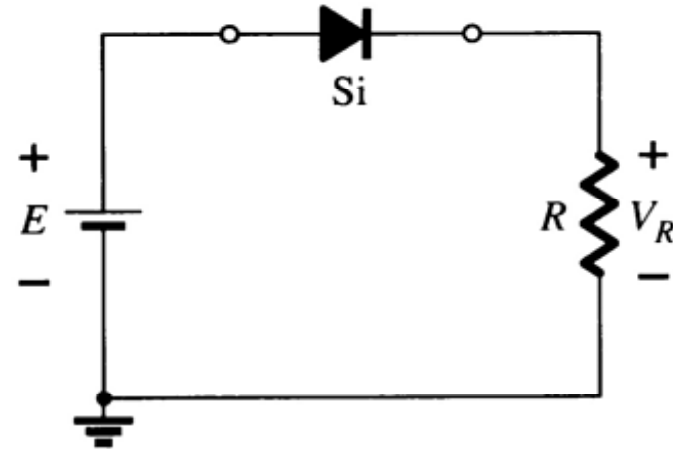

Parallel Configurations

$$V_D = 0.7 \text{ V}$$

$$V_{D1} = V_{D2} = V_O = 0.7 \text{ V}$$

$$V_R = 9.3 \text{ V}$$

$$I_R = \frac{E - V_D}{R} = \frac{10 \text{ V} - .7 \text{ V}}{.33 \text{ k}\Omega} = 28 \text{ mA}$$

$$I_{D1} = I_{D2} = \frac{28 \text{ mA}}{2} = 14 \text{ mA}$$

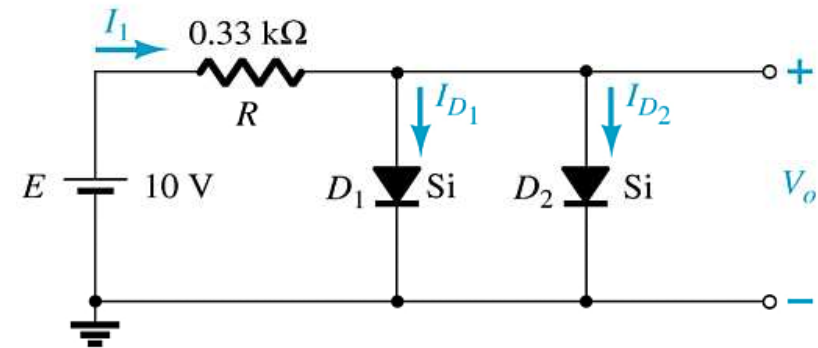

Half-Wave Rectification

The diode only conducts when it is forward biased, therefore only half of the AC cycle passes through the diode to the output.

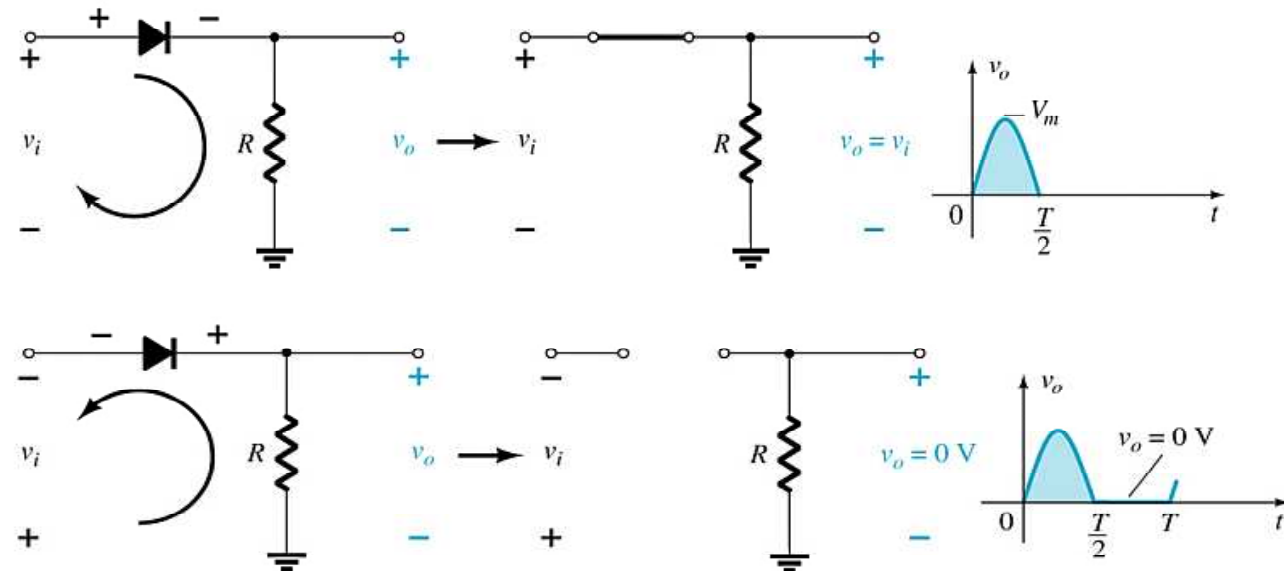

The DC output voltage is $0.318V_m$, where $V_m =$ the peak AC voltage.

PIV (PRV)

Because the diode is only forward biased for one-half of the AC cycle, it is also reverse biased for one-half cycle.

It is important that the reverse breakdown voltage rating of the diode be high enough to withstand the peak, reverse-biasing AC voltage.

$$\text{PIV (or PRV)} > V_m$$

- **PIV = Peak inverse voltage**
- **PRV = Peak reverse voltage**
- **V_m = Peak AC voltage**

Full-Wave Rectification

The rectification process can be improved by using a full-wave rectifier circuit.

Full-wave rectification produces a greater DC output:

- **Half-wave:** $V_{dc} = 0.318V_m$
- **Full-wave:** $V_{dc} = 0.636V_m$

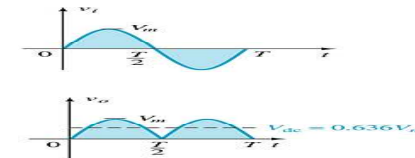

Full-Wave Rectification

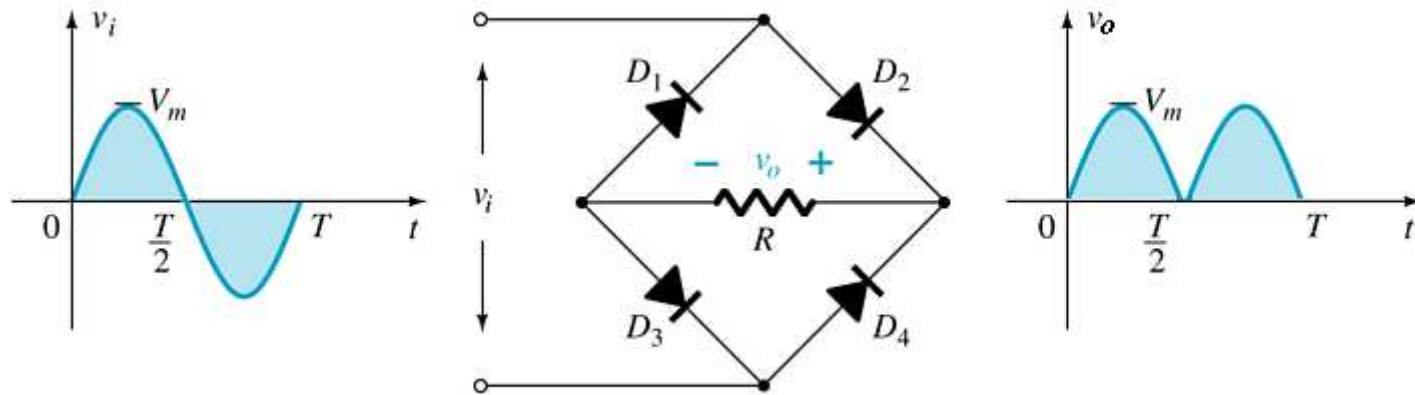

Bridge Rectifier

- Four diodes are connected in a bridge configuration
- $V_{DC} = 0.636V_m$

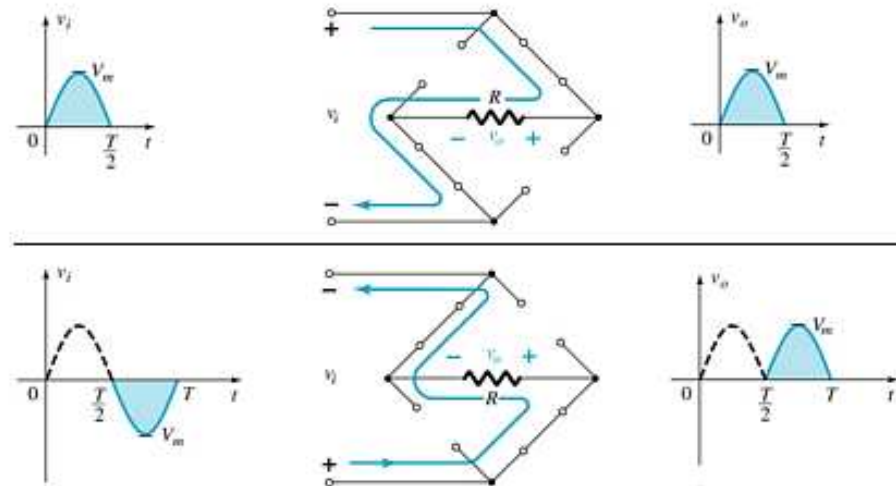

Full-Wave Rectification

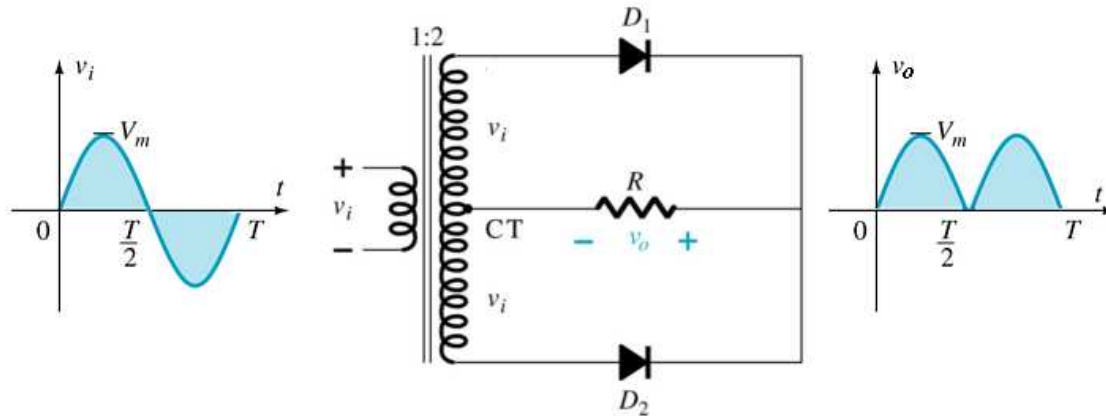

Center-Tapped Transformer Rectifier

Requires

- Two diodes
- Center-tapped transformer

$$V_{DC} = 0.636V_m$$

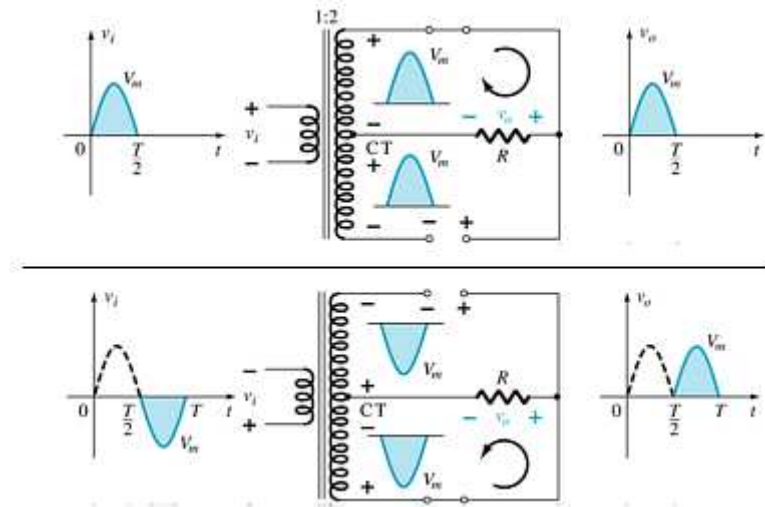

Summary of Rectifier Circuits

Rectifier	Ideal V_{DC}	Realistic V_{DC}
Half Wave Rectifier	$V_{DC} = 0.318V_m$	$V_{DC} = 0.318V_m - 0.7$
Bridge Rectifier	$V_{DC} = 0.636V_m$	$V_{DC} = 0.636V_m - 2(0.7 \text{ V})$
Center-Tapped Transformer Rectifier	$V_{DC} = 0.636V_m$	$V_{DC} = 0.636V_m - 0.7 \text{ V}$

V_m = peak of the AC voltage.

In the center tapped transformer rectifier circuit, the peak AC voltage is the transformer secondary voltage to the tap.

Diode Clippers

The diode in a **series clipper** “clips” any voltage that does not forward bias it:

- A reverse-biasing polarity
- A forward-biasing polarity less than 0.7 V (for a silicon diode)

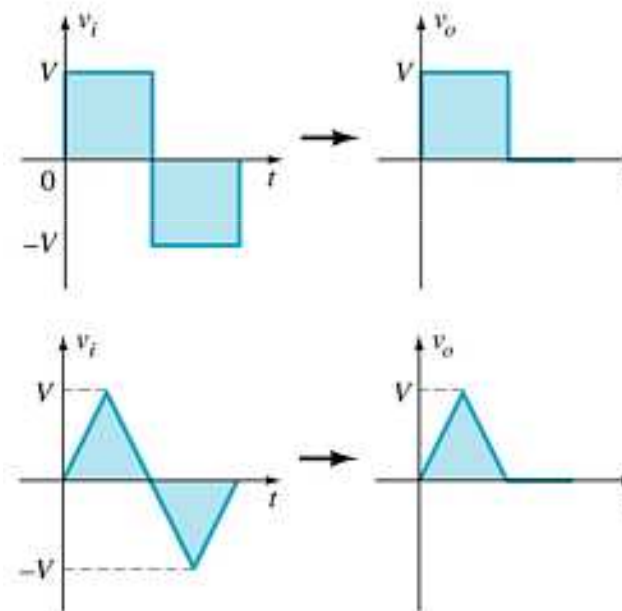
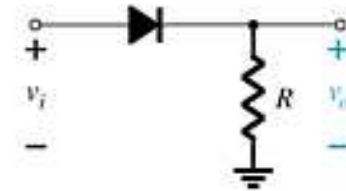

Biased Clippers

Adding a DC source in series with the clipping diode changes the effective forward bias of the diode.

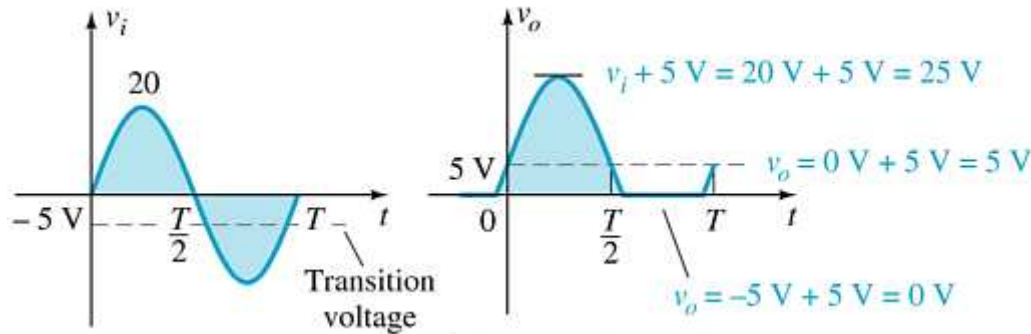
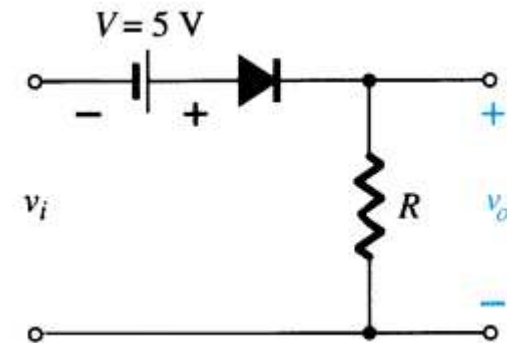
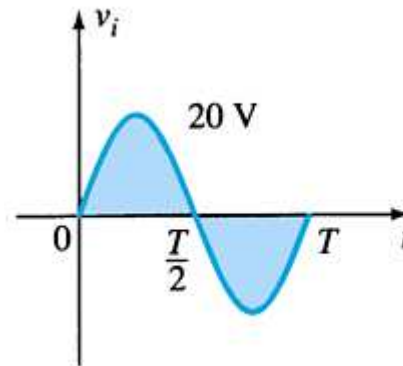

Parallel Clippers

The diode in a **parallel clipper** circuit “clips” any voltage that forward bias it.

DC biasing can be added in series with the diode to change the clipping level.

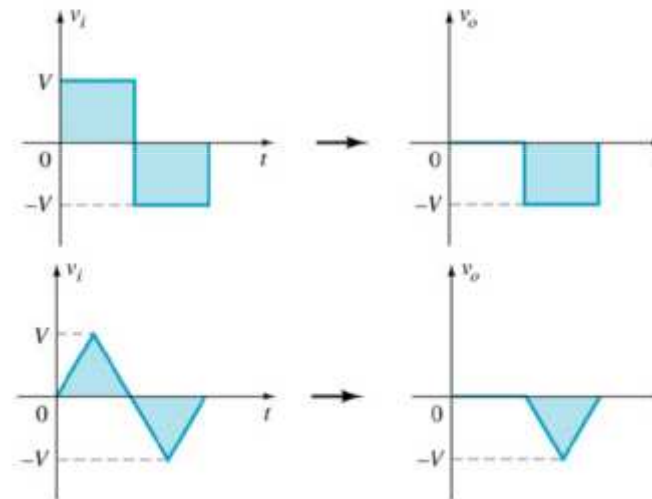
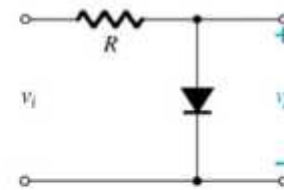

Summary of Clipper Circuits

Simple Parallel Clippers (Ideal Diodes)

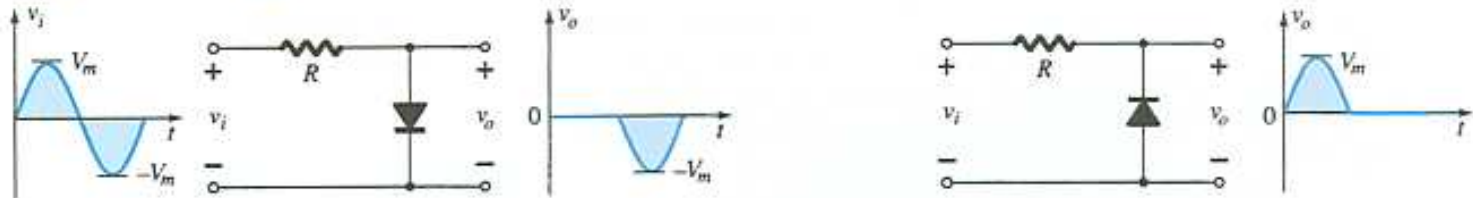

Biased Parallel Clippers (Ideal Diodes)

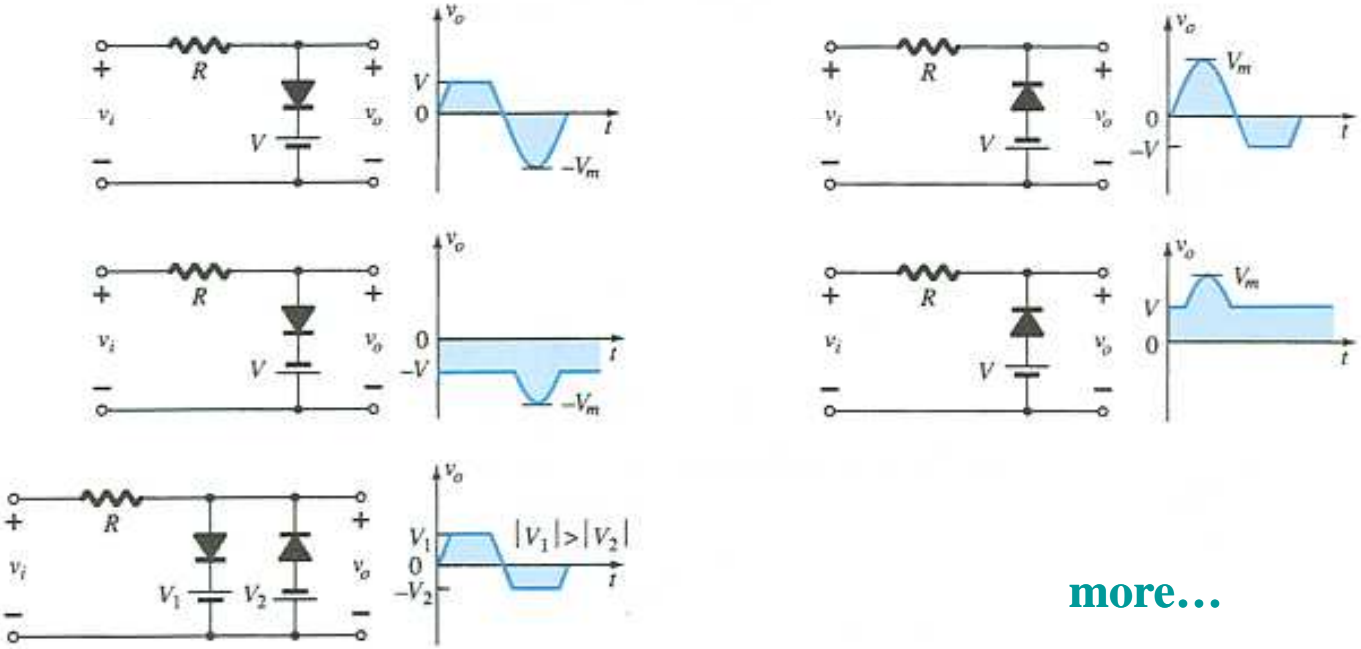

more...

Summary of Clipper Circuits

Simple Series Clippers (Ideal Diodes)

POSITIVE

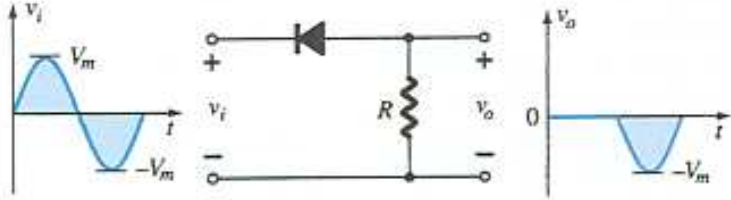

NEGATIVE

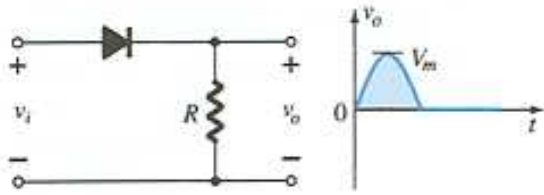

Biased Series Clippers (Ideal Diodes)

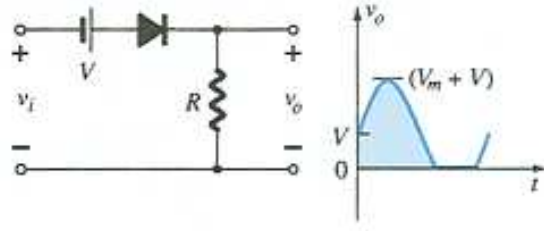
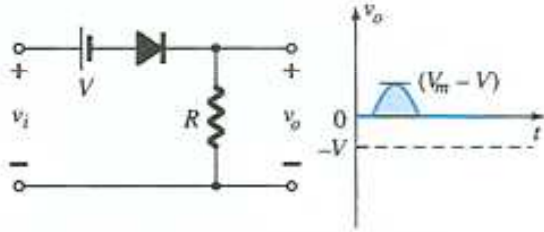
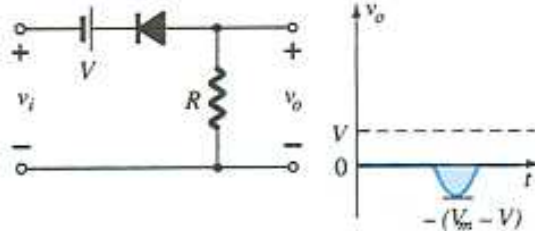
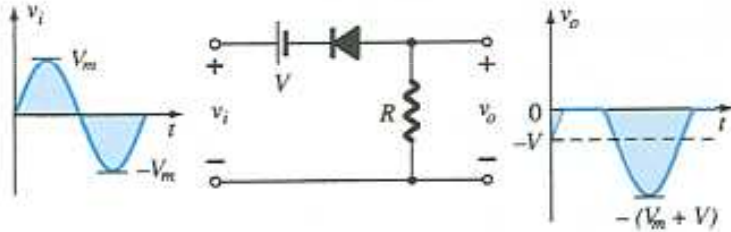

Clampers

A diode and capacitor can be combined to “clamp” an AC signal to a specific DC level.

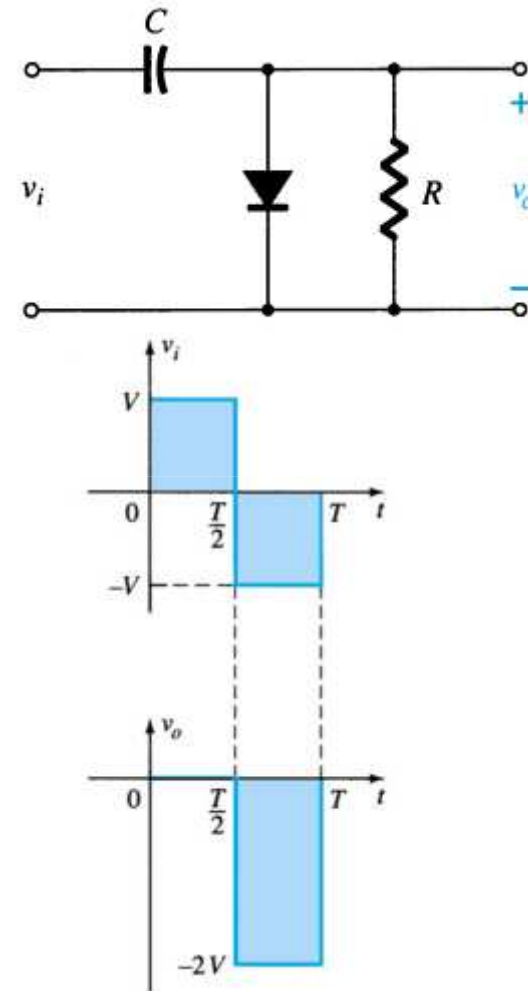

Biased Clamper Circuits

The input signal can be any type of waveform such as sine, square, and triangle waves.

The DC source lets you adjust the DC clamping level.

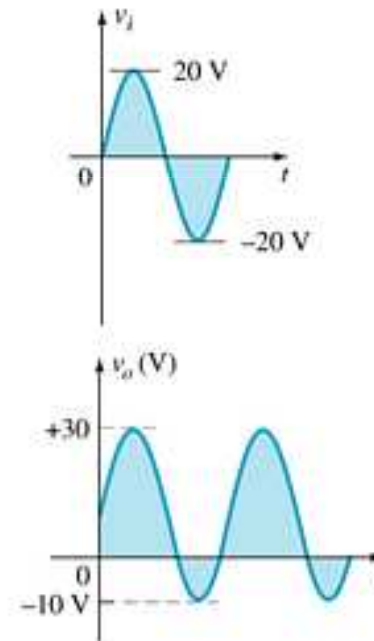
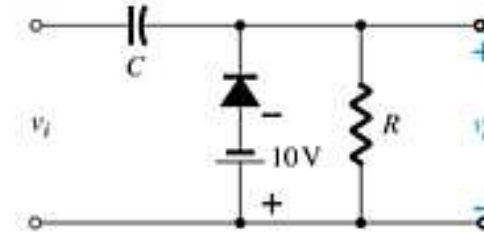

Summary of Clamper Circuits

Clamping Networks

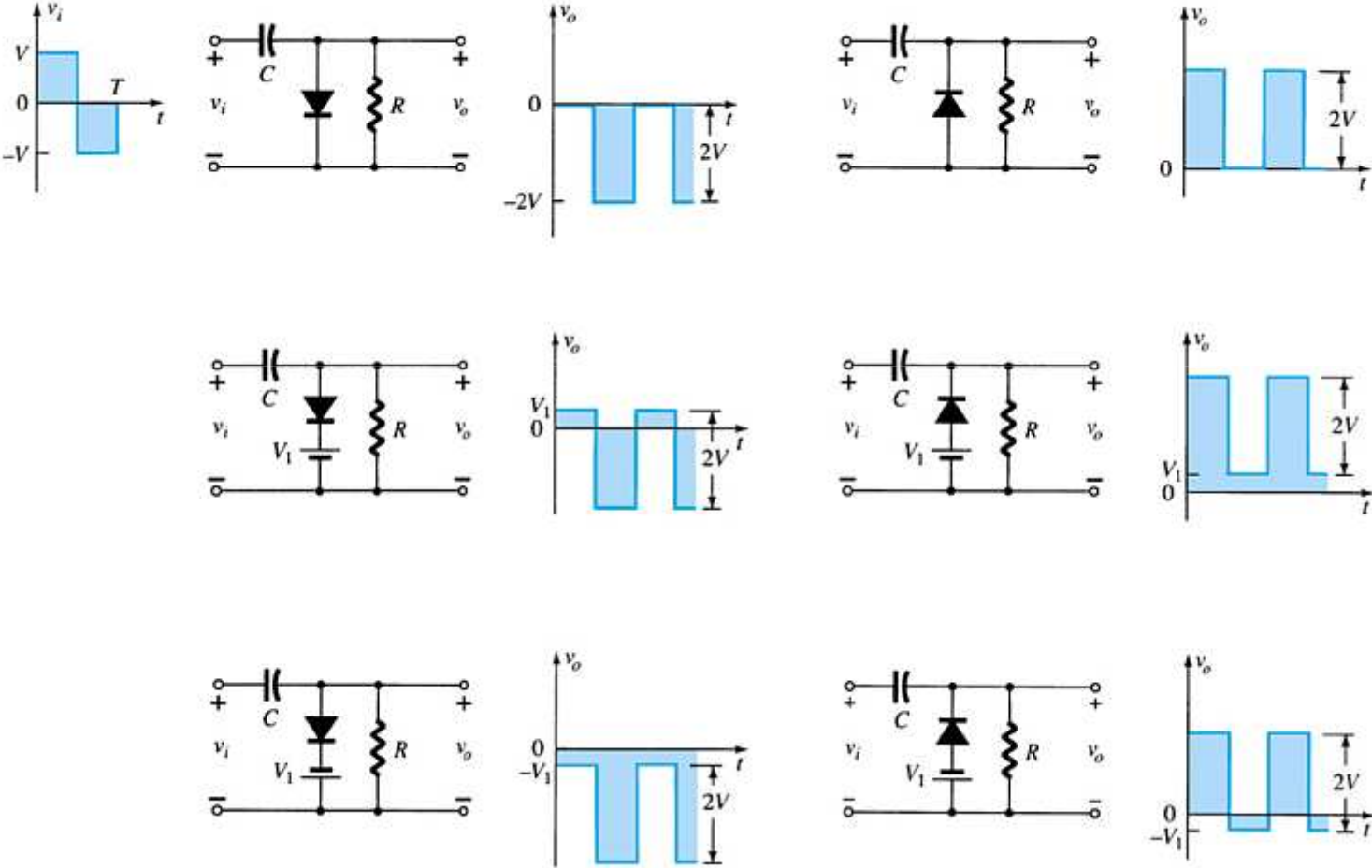

Zener Diodes

The Zener is a diode operated in reverse bias at the Zener Voltage (V_Z).

- When $V_i \geq V_Z$
 - The Zener is on
 - Voltage across the Zener is V_Z
 - Zener current: $I_Z = I_R - I_{RL}$
 - The Zener Power: $P_Z = V_Z I_Z$
- When $V_i < V_Z$
 - The Zener is off
 - The Zener acts as an open circuit

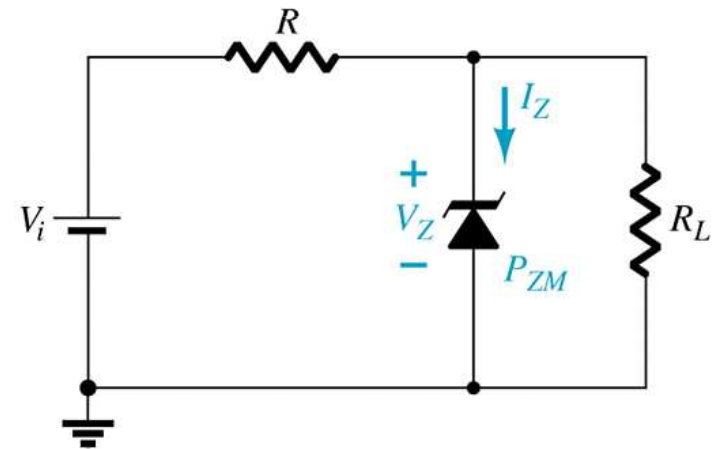
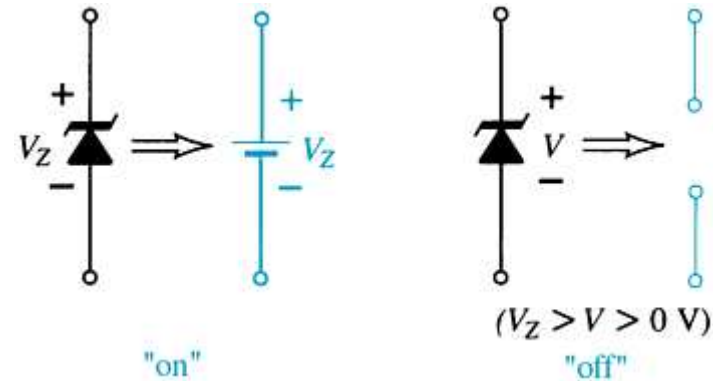

Zener Resistor Values

If R is too large, the Zener diode cannot conduct because the available amount of current is less than the minimum current rating, I_{ZK} . The minimum current is given by:

$$I_{Lmin} = I_R - I_{ZK}$$

The *maximum* value of resistance is:

$$R_{Lmax} = \frac{V_Z}{I_{Lmin}}$$

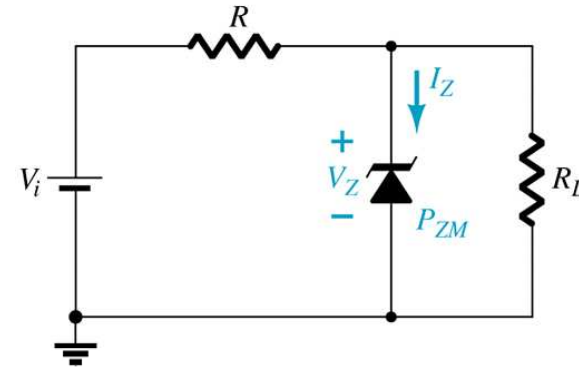

If R is too small, the Zener current exceeds the maximum current rating, I_{ZM} . The maximum current for the circuit is given by:

$$I_{Lmax} = \frac{V_L}{R_L} = \frac{V_Z}{R_{Lmin}}$$

The *minimum* value of resistance is:

$$R_{Lmin} = \frac{RV_Z}{V_i - V_Z}$$

Voltage-Multiplier Circuits

Voltage multiplier circuits use a combination of diodes and capacitors to step up the output voltage of rectifier circuits.

- **Voltage Doubler**
- **Voltage Tripler**
- **Voltage Quadrupler**

Voltage Doubler

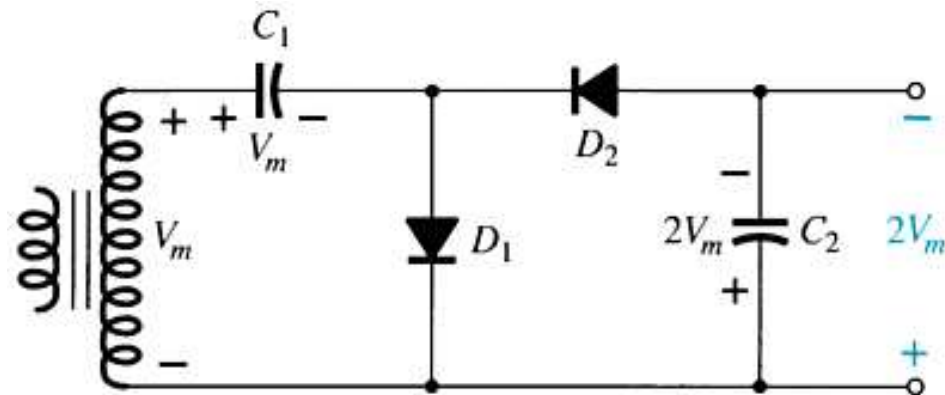

This half-wave voltage doubler's output can be calculated by:

$$V_{\text{out}} = V_{C2} = 2V_m$$

where V_m = peak secondary voltage of the transformer

Voltage Doubler

- **Positive Half-Cycle**
 - D_1 conducts
 - D_2 is switched off
 - Capacitor C_1 charges to V_m
- **Negative Half-Cycle**
 - D_1 is switched off
 - D_2 conducts
 - Capacitor C_2 charges to V_m

$$V_{\text{out}} = V_{C_2} = 2V_m$$

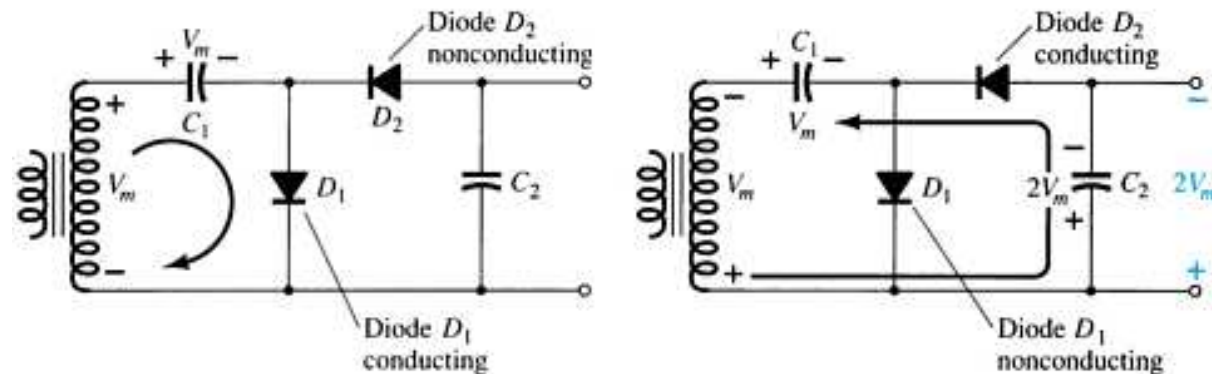

Voltage Tripler and Quadrupler

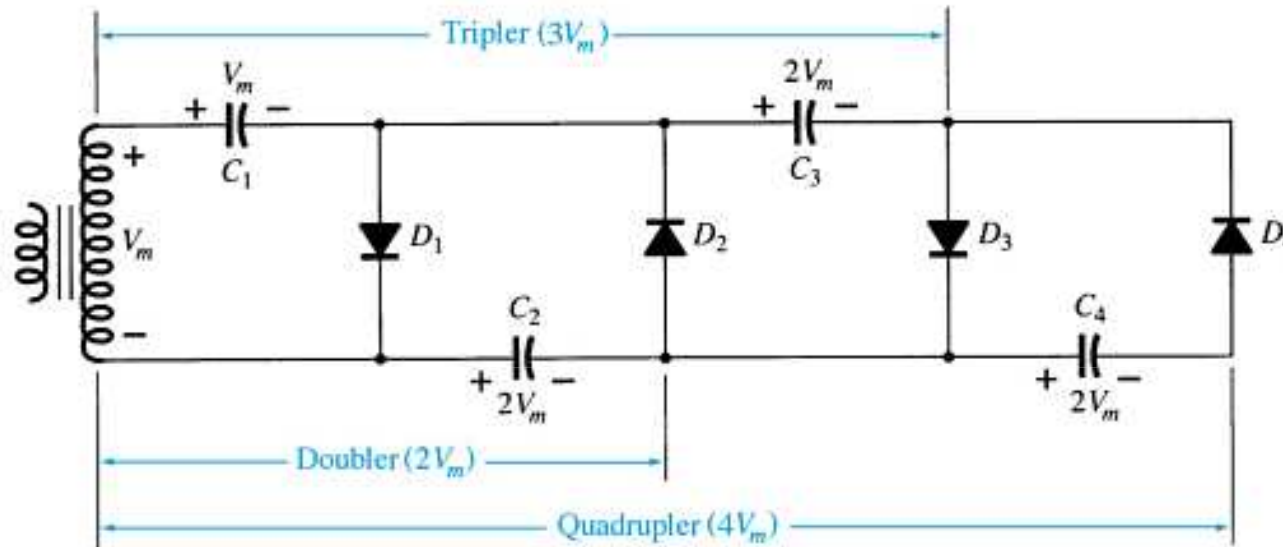

Practical Applications

- **Rectifier Circuits**
 - **Conversions of AC to DC for DC operated circuits**
 - **Battery Charging Circuits**
- **Simple Diode Circuits**
 - **Protective Circuits against**
 - **Overcurrent**
 - **Polarity Reversal**
 - **Currents caused by an inductive kick in a relay circuit**
- **Zener Circuits**
 - **Overvoltage Protection**
 - **Setting Reference Voltages**