

ELECTRONIC DEVICES AND CIRCUIT THEORY

TENTH EDITION

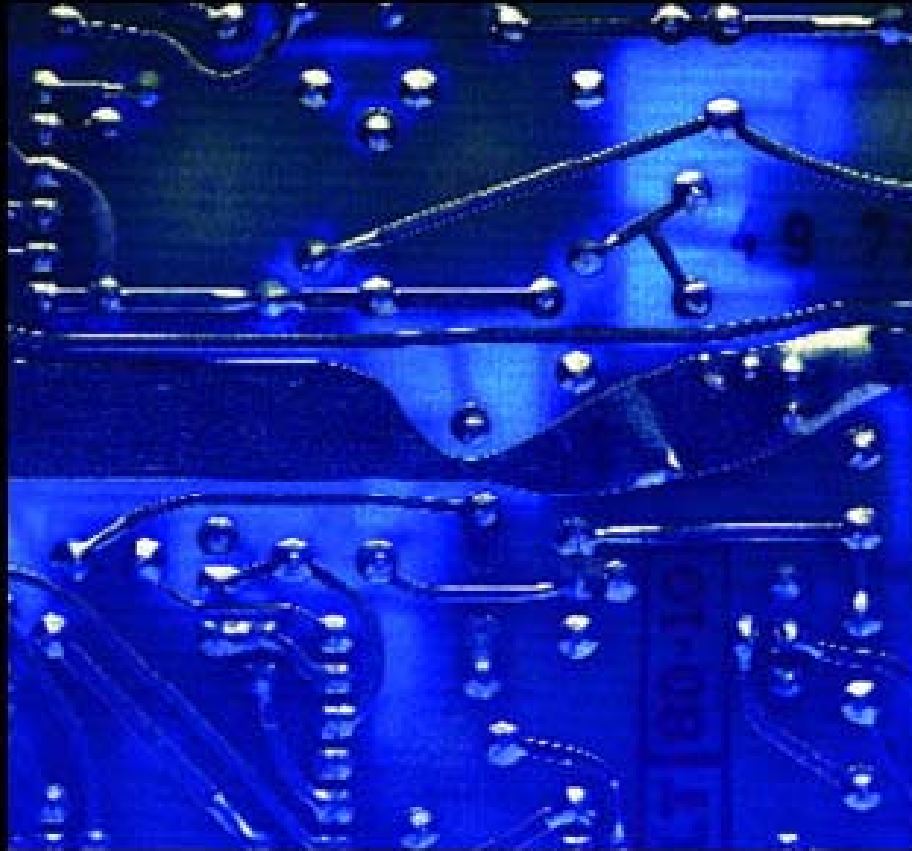

BOYLESTAD

PEARSON

Chapter 4 DC Biasing–BJTs

Biasing

Biasing: The DC voltages applied to a transistor in order to turn it on so that it can amplify the AC signal.

Operating Point

The DC input establishes an operating or *quiescent point* called the *Q-point*.

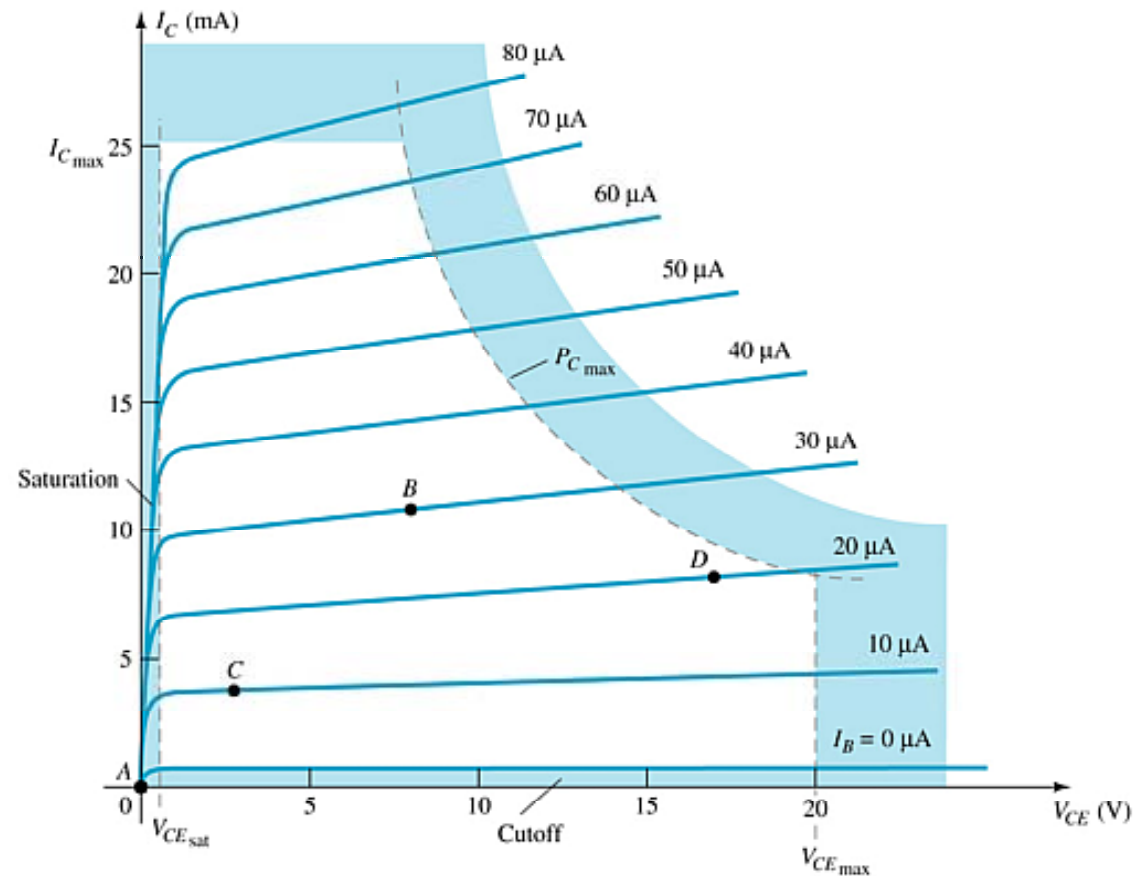

The Three States of Operation

- **Active or Linear Region Operation**

Base–Emitter junction is forward biased

Base–Collector junction is reverse biased

- **Cutoff Region Operation**

Base–Emitter junction is reverse biased

- **Saturation Region Operation**

Base–Emitter junction is forward biased

Base–Collector junction is forward biased

DC Biasing Circuits

- **Fixed-bias circuit**
- **Emitter-stabilized bias circuit**
- **Collector-emitter loop**
- **Voltage divider bias circuit**
- **DC bias with voltage feedback**

Fixed Bias

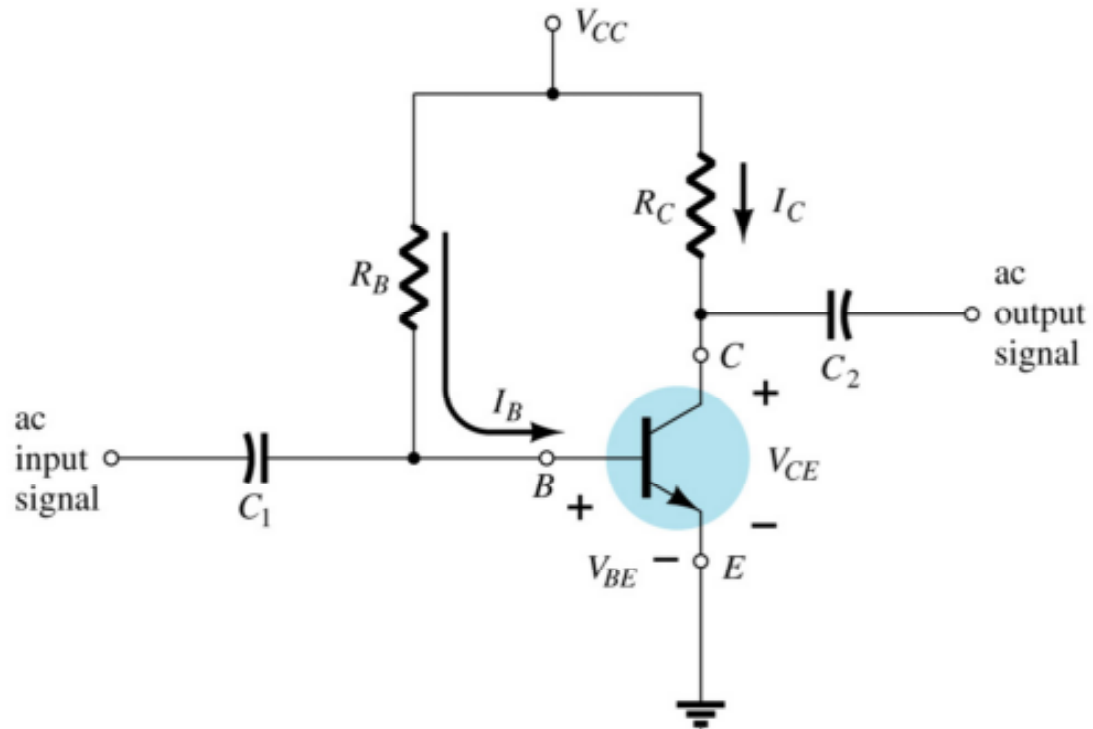

The Base-Emitter Loop

From Kirchhoff's voltage law:

$$+V_{CC} - I_B R_B - V_{BE} = 0$$

Solving for base current:

$$I_B = \frac{V_{CC} - V_{BE}}{R_B}$$

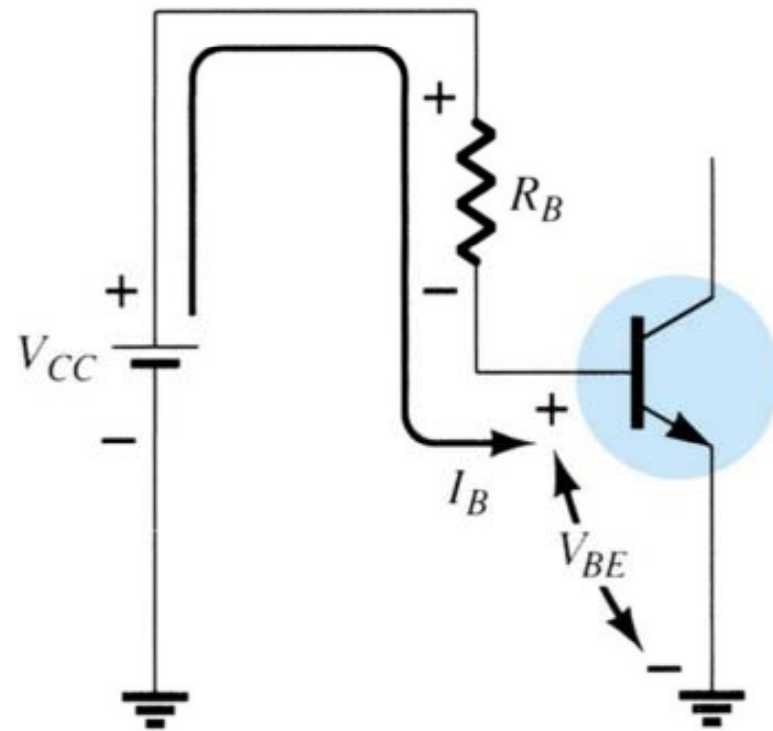

Collector-Emitter Loop

Collector current:

$$I_C = \beta I_B$$

From Kirchhoff's voltage law:

$$V_{CE} = V_{CC} - I_C R_C$$

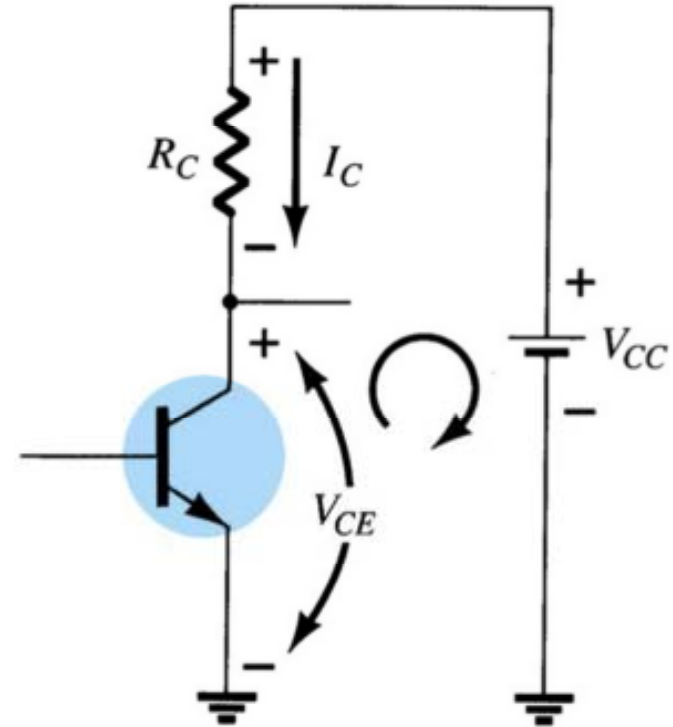

Saturation

When the transistor is operating in saturation, current through the transistor is at its *maximum* possible value.

$$I_{C\text{sat}} = \frac{V_{CC}}{R_C}$$

$$V_{CE} \cong 0 \text{ V}$$

Load Line Analysis

The end points of the load line are:

$I_{C\text{sat}}$

$$I_C = V_{CC} / R_C$$

$$V_{CE} = 0 \text{ V}$$

$V_{CE\text{cutoff}}$

$$V_{CE} = V_{CC}$$

$$I_C = 0 \text{ mA}$$

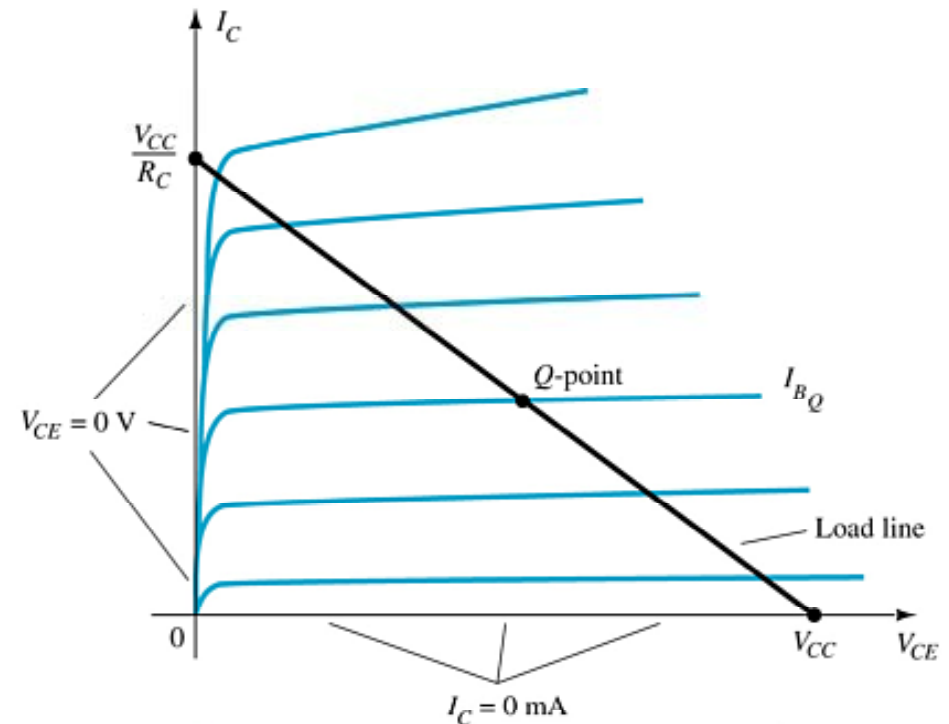

The Q -point is the operating point:

- where the value of R_B sets the value of I_B
- that sets the values of V_{CE} and I_C

Circuit Values Affect the Q-Point

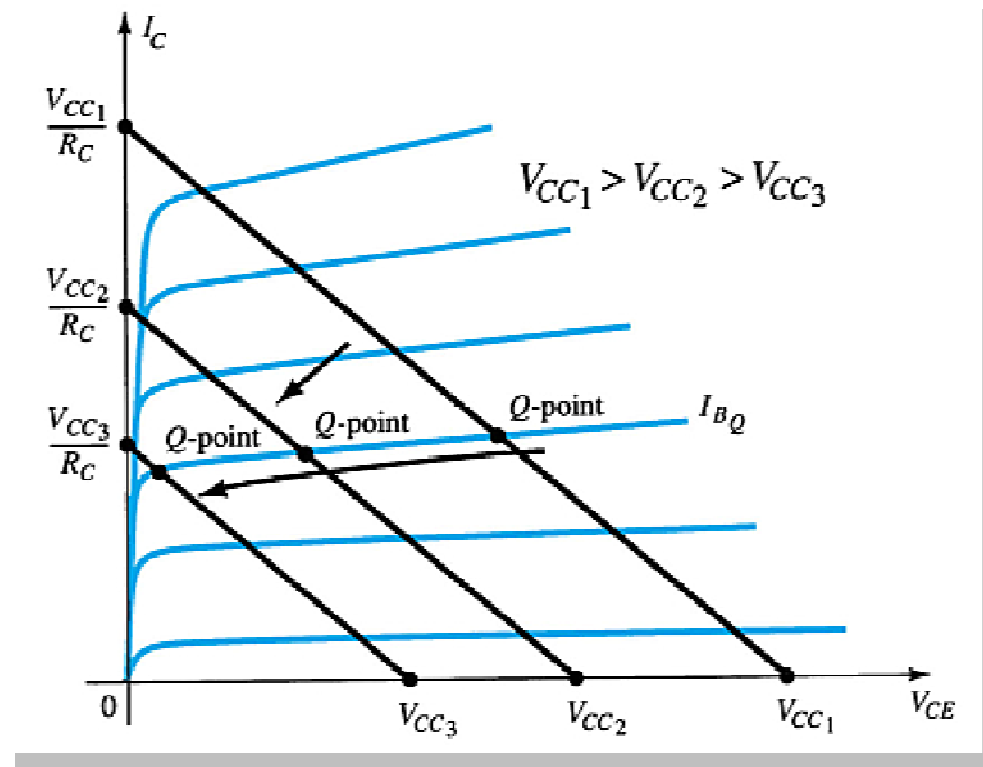

more ...

Circuit Values Affect the Q-Point

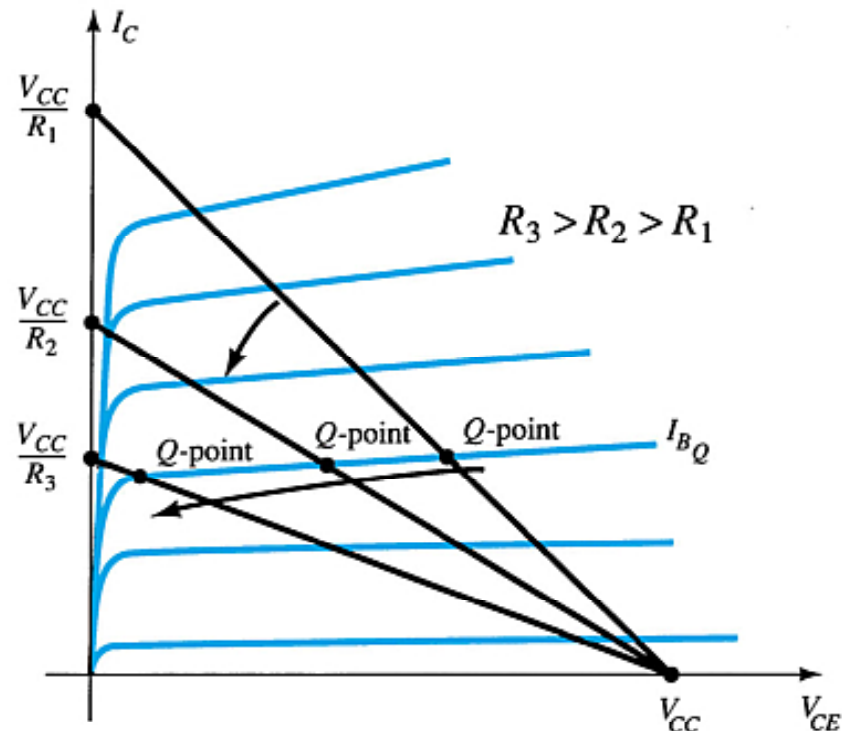

more ...

Circuit Values Affect the Q-Point

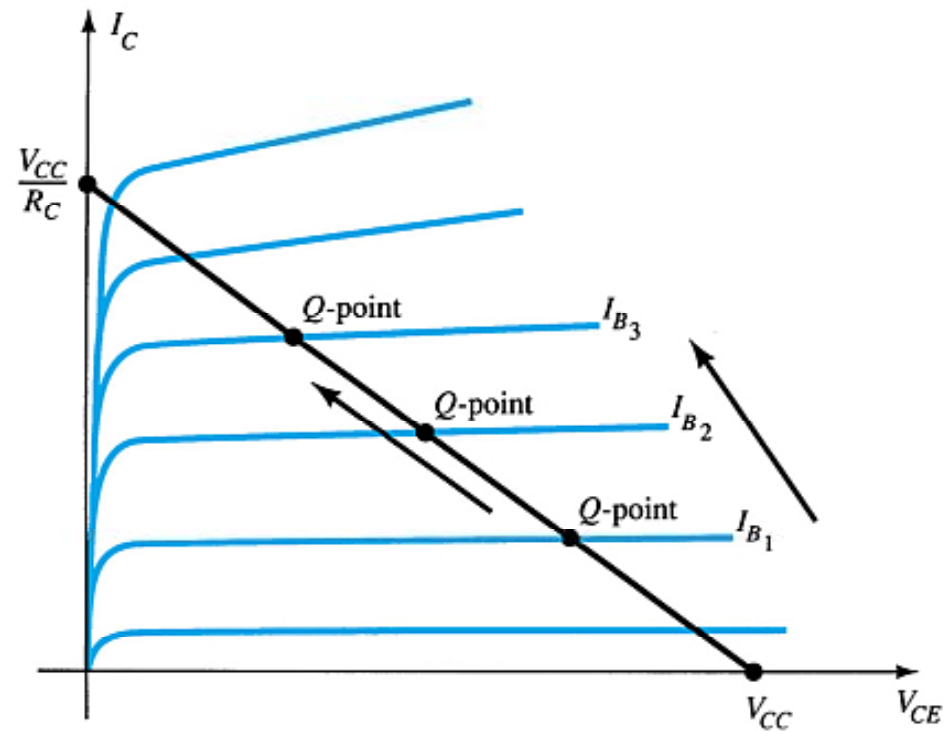

Emitter-Stabilized Bias Circuit

Adding a resistor (R_E) to the emitter circuit stabilizes the bias circuit.

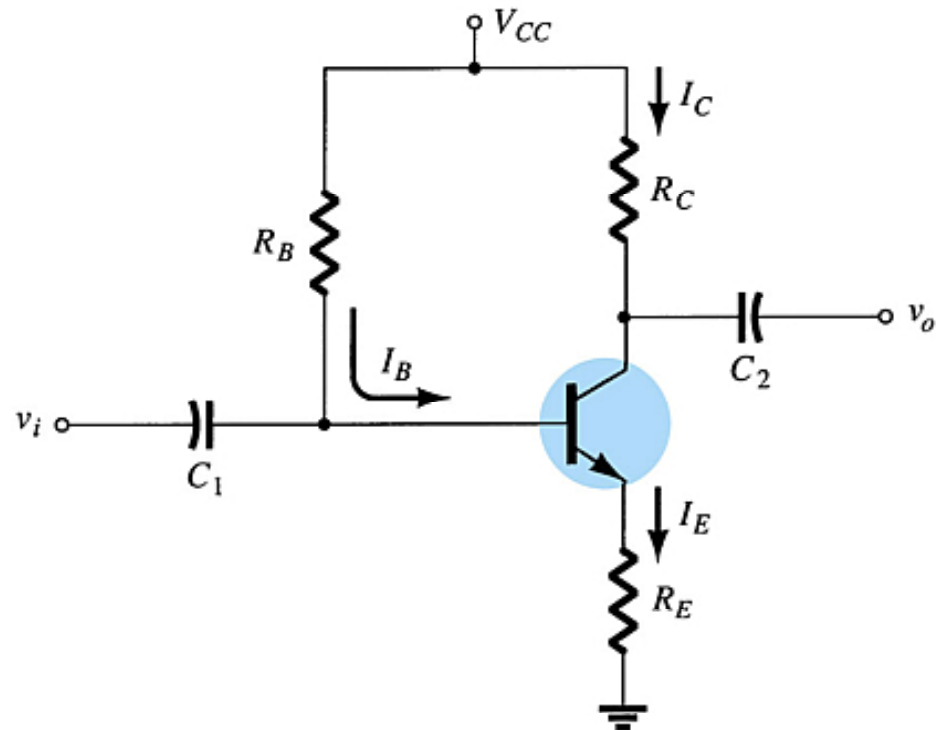

Base-Emitter Loop

From Kirchhoff's voltage law:

$$+ V_{CC} - I_E R_E - V_{BE} - I_E R_E = 0$$

Since $I_E = (\beta + 1)I_B$:

$$V_{CC} - I_B R_B - (\beta + 1)I_B R_E = 0$$

Solving for I_B :

$$I_B = \frac{V_{CC} - V_{BE}}{R_B + (\beta + 1)R_E}$$

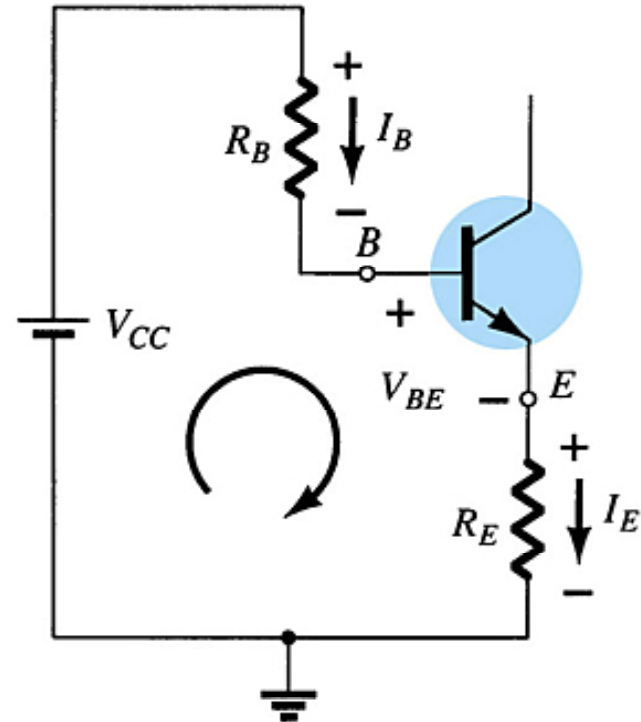

Collector-Emitter Loop

From Kirchhoff's voltage law:

$$I_E R_E + V_{CE} + I_C R_C - V_{CC} = 0$$

Since $I_E \cong I_C$:

$$V_{CE} = V_{CC} - I_C (R_C + R_E)$$

Also:

$$V_E = I_E R_E$$

$$V_C = V_{CE} + V_E = V_{CC} - I_C R_C$$

$$V_B = V_{CC} - I_R R_B = V_{BE} + V_E$$

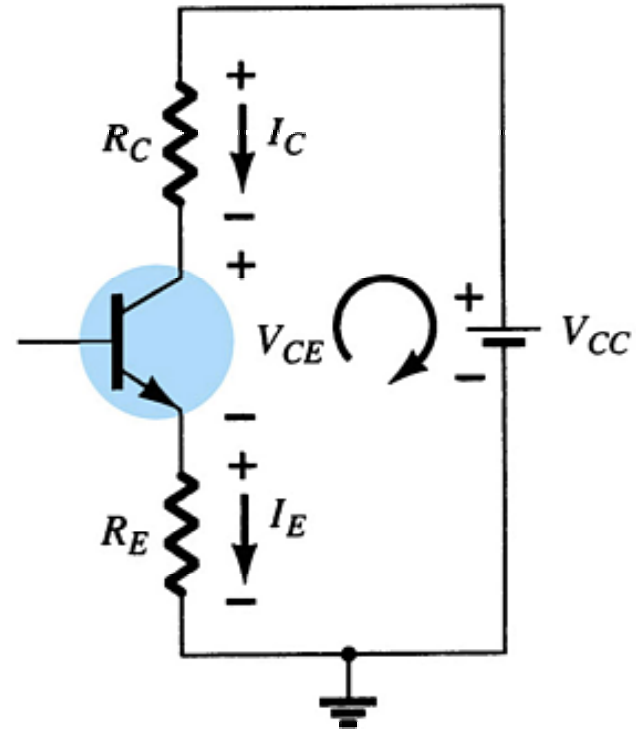

Improved Biased Stability

Stability refers to a circuit condition in which the currents and voltages will remain fairly constant over a wide range of temperatures and transistor Beta (β) values.

Adding RE to the emitter improves the stability of a transistor.

Saturation Level

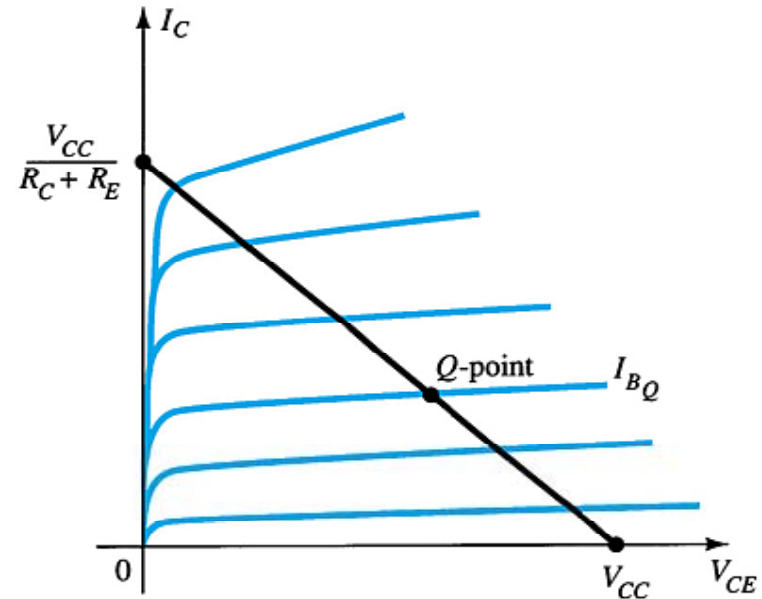
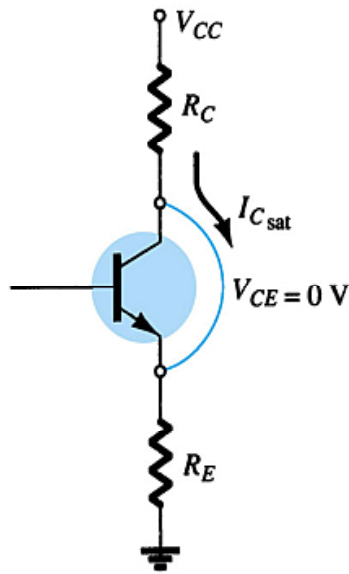

The endpoints can be determined from the load line.

$V_{CE\text{cutoff}}$:

$$V_{CE} = V_{CC}$$

$$I_C = 0 \text{ mA}$$

$I_{C\text{sat}}$:

$$V_{CE} = 0 \text{ V}$$

$$I_C = \frac{V_{CC}}{R_C + R_E}$$

Voltage Divider Bias

This is a very stable bias circuit.

The currents and voltages are nearly independent of any variations in β .

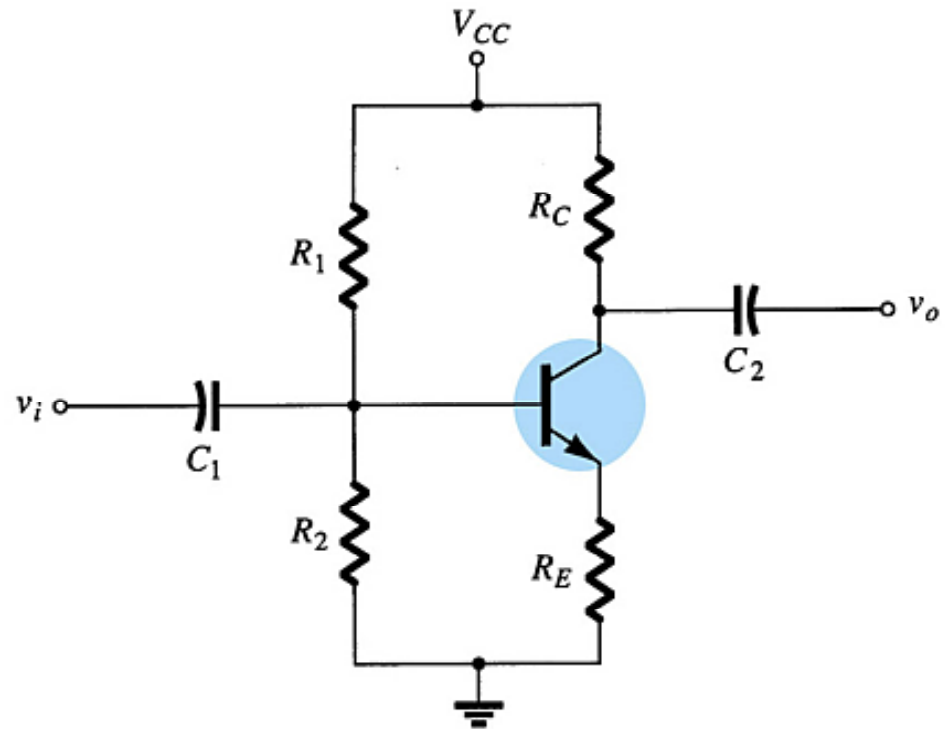

Approximate Analysis

Where $I_B \ll I_1$ and $I_1 \cong I_2$:

$$V_B = \frac{R_2 V_{CC}}{R_1 + R_2}$$

Where $\beta R_E > 10R_2$:

$$I_E = \frac{V_E}{R_E}$$

$$V_E = V_B - V_{BE}$$

From Kirchhoff's voltage law:

$$V_{CE} = V_{CC} - I_C R_C - I_E R_E$$

$$I_E \cong I_C$$

$$V_{CE} = V_{CC} - I_C (R_C + R_E)$$

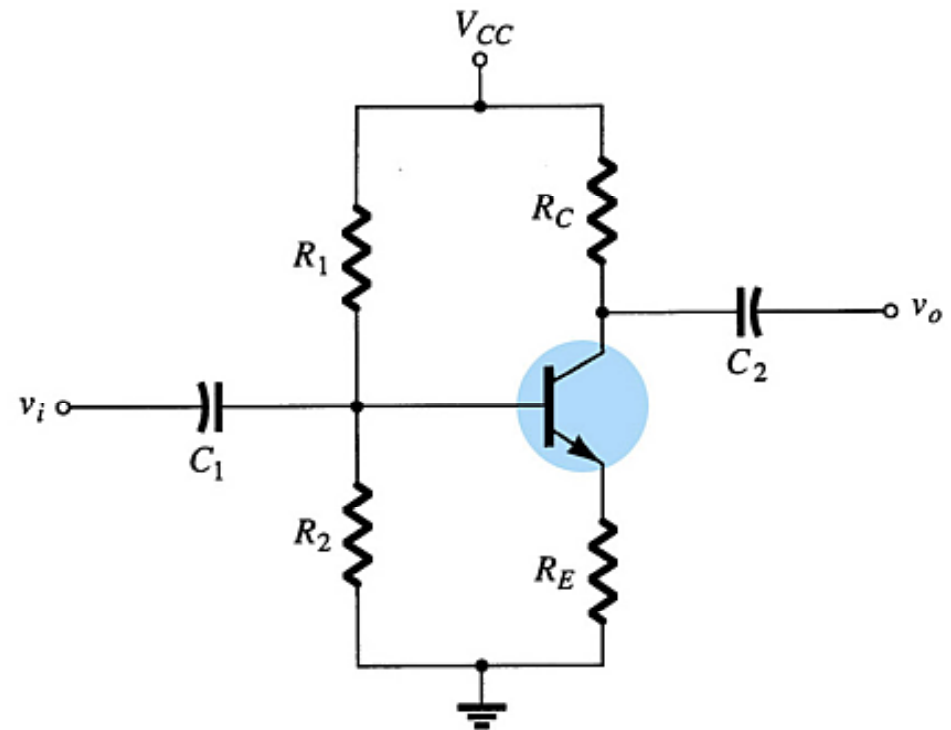

Voltage Divider Bias Analysis

Transistor Saturation Level

$$I_{C\text{sat}} = I_{C\text{max}} = \frac{V_{CC}}{R_C + R_E}$$

Load Line Analysis

Cutoff:

$$V_{CE} = V_{CC}$$

$$I_C = 0\text{mA}$$

Saturation:

$$I_C = \frac{V_{CC}}{R_C + R_E}$$

$$V_{CE} = 0\text{V}$$

DC Bias with Voltage Feedback

Another way to improve the stability of a bias circuit is to add a feedback path from collector to base.

In this bias circuit the Q-point is only slightly dependent on the transistor beta, β .

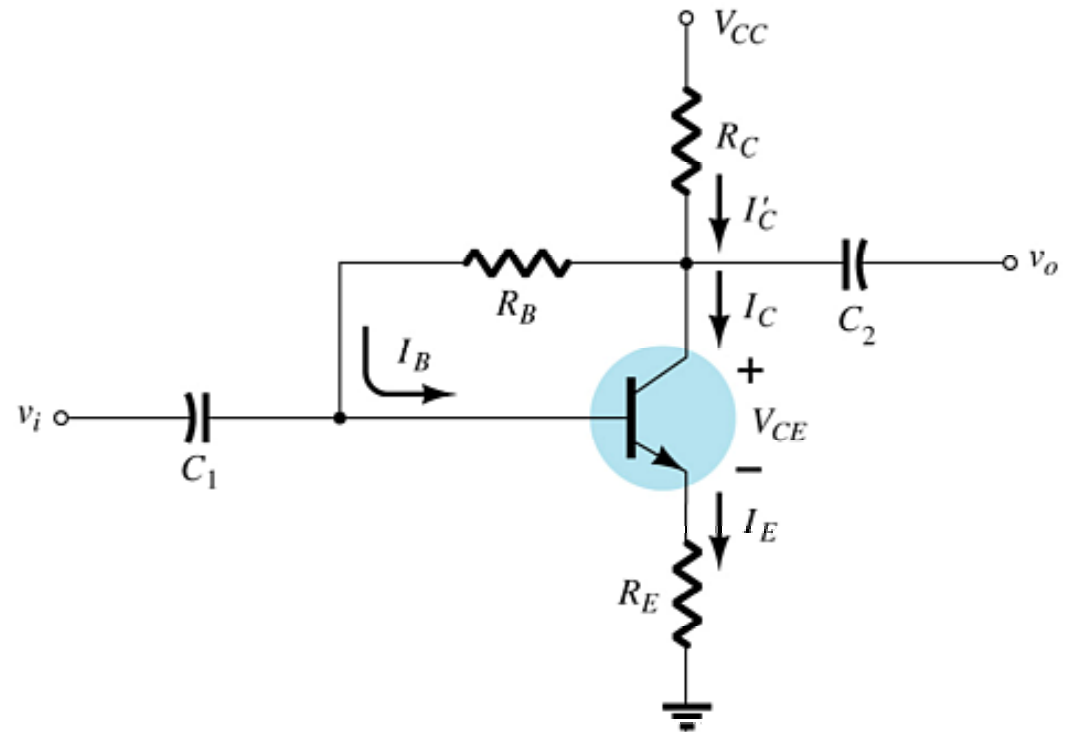

Base-Emitter Loop

From Kirchhoff's voltage law:

$$V_{CC} - I'_C R_C - I_B R_B - V_{BE} - I_E R_E = 0$$

Where $I_B \ll I_C$:

$$I'_C = I_C + I_B \cong I_C$$

Knowing $I_C = \beta I_B$ and $I_E \cong I_C$, the loop equation becomes:

$$V_{CC} - \beta I_B R_C - I_B R_B - V_{BE} - \beta I_B R_E = 0$$

Solving for I_B :

$$I_B = \frac{V_{CC} - V_{BE}}{R_B + \beta(R_C + R_E)}$$

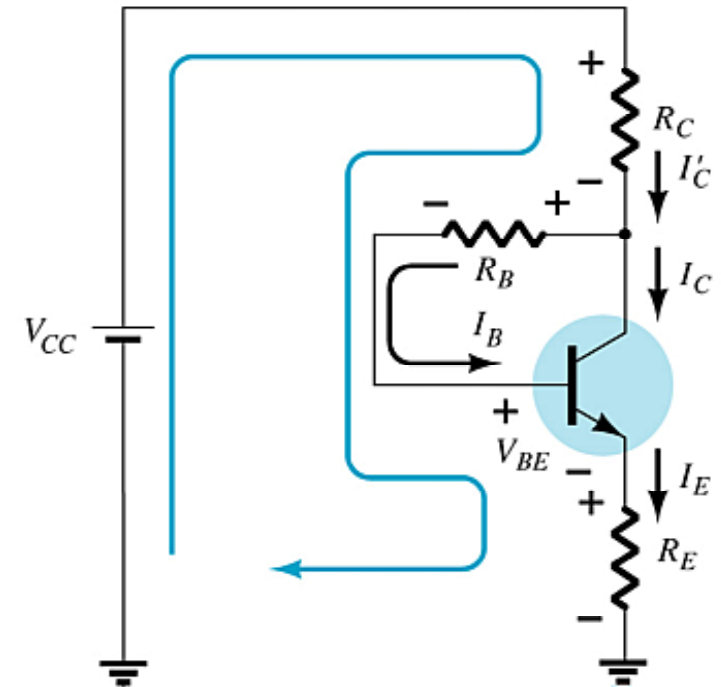

Collector-Emitter Loop

Applying Kirchoff's voltage law:

$$I_E + V_{CE} + I'_C R_C - V_{CC} = 0$$

Since $I'_C \cong I_C$ and $I_C = \beta I_B$:

$$I_C(R_C + R_E) + V_{CE} - V_{CC} = 0$$

Solving for V_{CE} :

$$V_{CE} = V_{CC} - I_C(R_C + R_E)$$

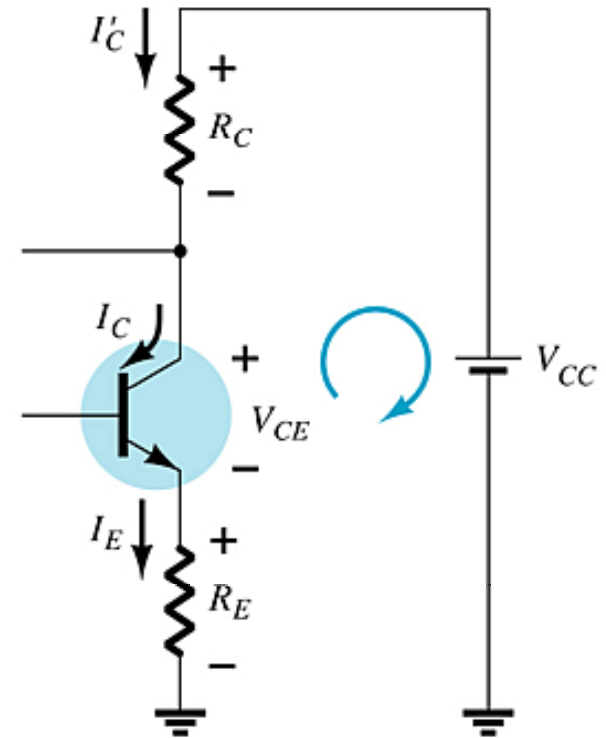

Base-Emitter Bias Analysis

Transistor Saturation Level

$$I_{C\text{sat}} = I_{C\text{max}} = \frac{V_{CC}}{R_C + R_E}$$

Load Line Analysis

Cutoff:

$$V_{CE} = V_{CC}$$
$$I_C = 0 \text{ mA}$$

Saturation:

$$I_C = \frac{V_{CC}}{R_C + R_E}$$
$$V_{CE} = 0 \text{ V}$$

Transistor Switching Networks

Transistors with only the DC source applied can be used as electronic switches.

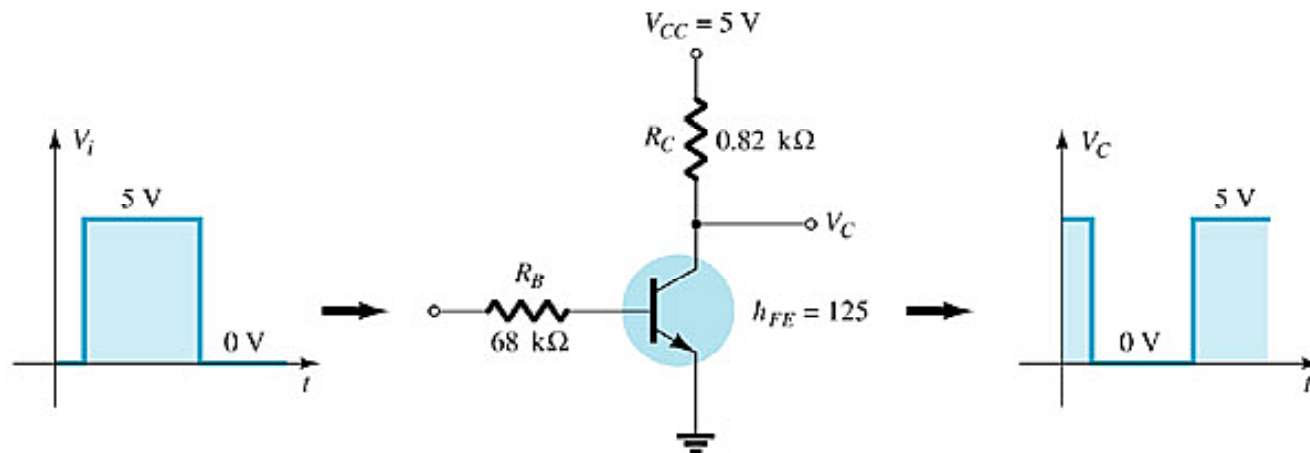

Switching Circuit Calculations

Saturation current:

$$I_{C\text{sat}} = \frac{V_{CC}}{R_C}$$

To ensure saturation:

$$I_B > \frac{I_{C\text{sat}}}{\beta_{dc}}$$

**Emitter-collector resistance
at saturation and cutoff:**

$$R_{\text{sat}} = \frac{V_{CE\text{sat}}}{I_{C\text{sat}}}$$

$$R_{\text{cutoff}} = \frac{V_{CC}}{I_{CEO}}$$

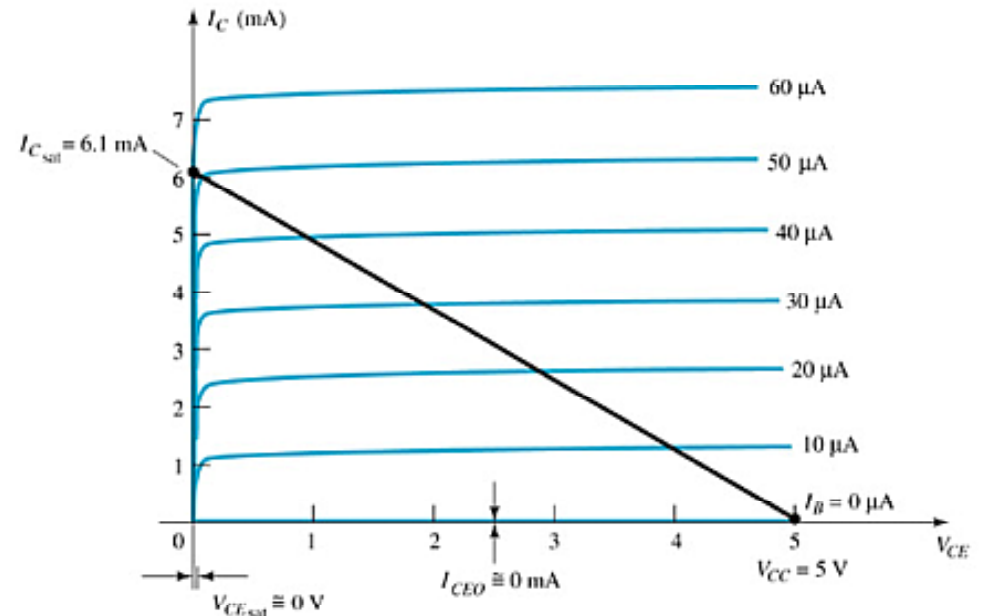

Switching Time

Transistor switching times:

$$t_{\text{on}} = t_r + t_d$$

$$t_{\text{off}} = t_s + t_f$$

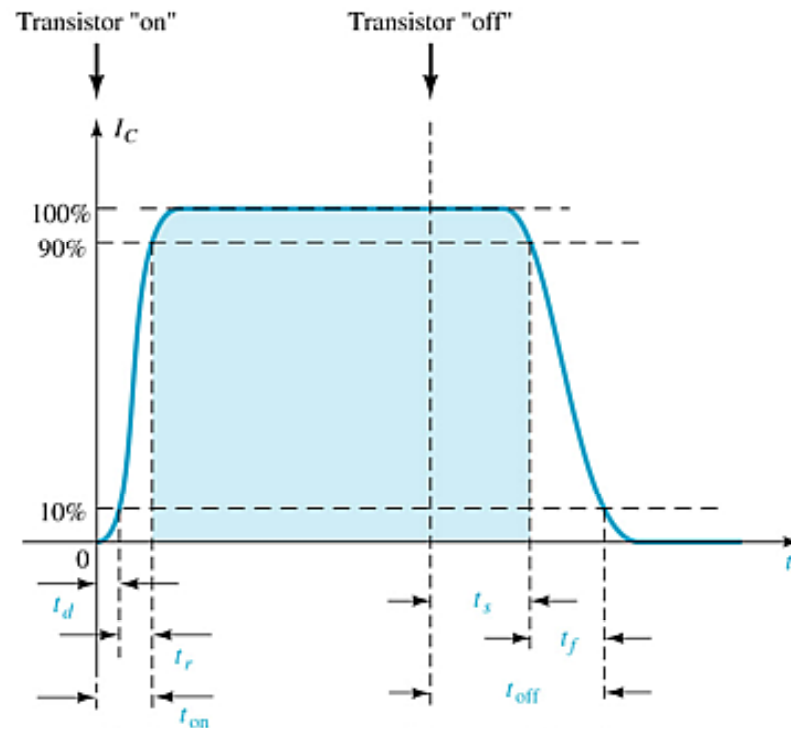

Troubleshooting Hints

- **Approximate voltages**
 - $V_{BE} \cong .7 \text{ V}$ for silicon transistors
 - $V_{CE} \cong 25\% \text{ to } 75\% \text{ of } V_{CC}$
- **Test for opens and shorts with an ohmmeter.**
- **Test the solder joints.**
- **Test the transistor with a transistor tester or a curve tracer.**
- **Note that the load or the next stage affects the transistor operation.**

PNP Transistors

The analysis for *pnp* transistor biasing circuits is the same as that for *nnp* transistor circuits. The only difference is that the currents are flowing in the opposite direction.