



Expression system

expression vector

- ◆ Definition :

An **expression vector**, otherwise known as an **expression construct**, is usually a plasmid or virus designed for protein expression in cells

pGEX-3X plasmid

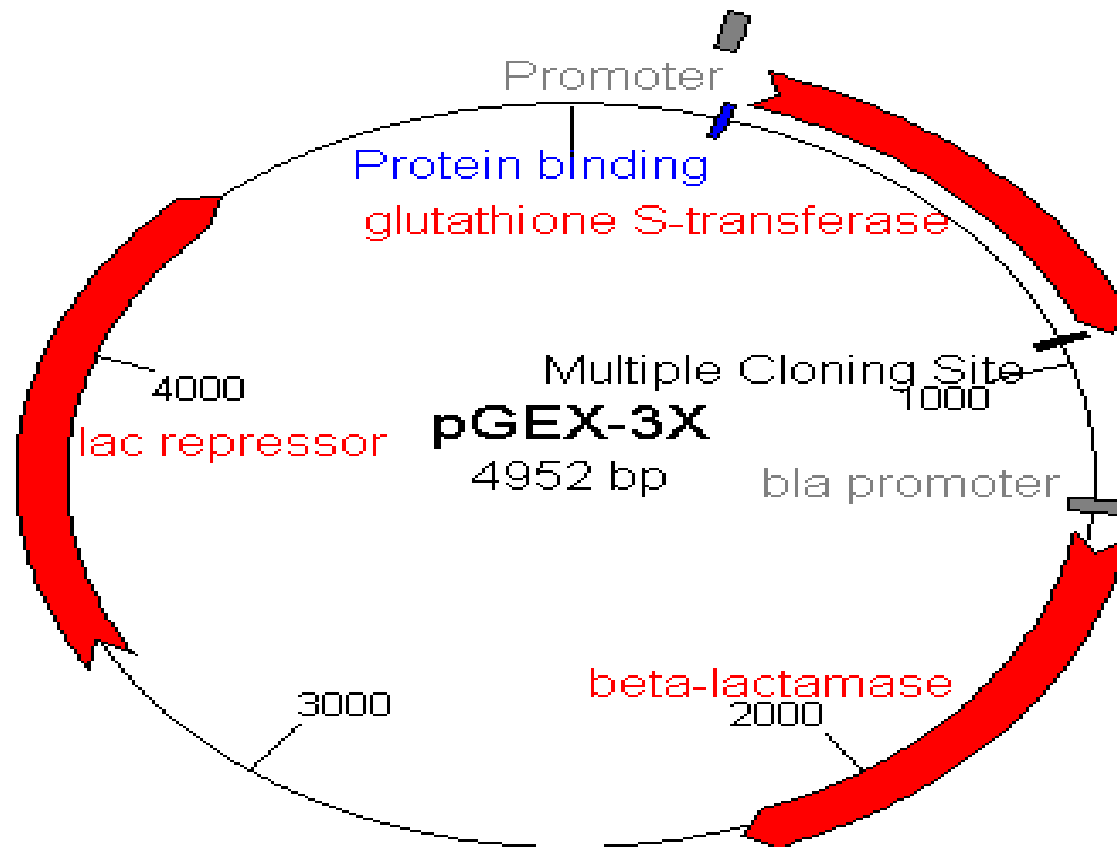

Difference between cloning vectors and expression vectors

- ◆ **Cloning vectors:**
- ◆ Cloning vectors are the DNA molecules that can carry a foreign dna segment in to the host cell. The vectors used in rDNA technology can be
- ◆ **Plasmids:** Self replicating, circular, extra chromosomal dna present in bacteria. plasmids have one or two copies per cell
- ◆ **Bacteriophages:** Virus infecting bacteria. bacteriophages have a high copy number per cell, so their copy number is also high in genome
- ◆ **Cosmids:** Hybrid vectors derived from plasmids which contain cos site of lambda phage

Expression vectors

- ◆ The cloning vector containing suitable expression signals to have maximum gene for expression is called expression vector.
- ◆ The following expression signals are introduced in to gene cloned vectors to get maximum expression:
 - ◆ Insertion of a strong promoter.
 - ◆ Insertion of a strong termination codon.
 - ◆ Adjustment of distance between promoter and cloned gene.
 - ◆ Insertion of transcription termination sequence.
 - ◆ Insertion of a strong translation initiation sequence.

Expression in Prokaryotes

Promoter – commonly used inducible promoters are promoters derived from *lac* operon and the T7 promoter.

Other strong promoters used include Trp promoter and Tac Promoter, which is a hybrid of both the Trp and Lac Operon promoters

Ribosome binding site (RBS) Follows the promoter, and promotes efficient translation of the protein of interest.

Translation initiation site: shine dalgarno sequence enclosed in the RBS, 8 base-pairs upstream of the AUG start codon

Posttranslational Modification

- Eukaryotic protein synthesis occurs in cytoplasm or on the endoplasmic reticulum.

- These proteins are further post translational processed that is required for protein activity and stability.

- Disulfide isomerase also makes sure that the proteins produced have the correct configuration.

- The proper glycosylation that are necessary for protein conformation, localization by interacting with specific receptor and increase stability.

Eukaryotic Expression Systems

- ◆ Eukaryotic expression vectors require sequences that encode for:
- ◆ **Polyadenylation tail**: Creates a polyadenylation tail at the end of the transcribed pre-mRNA that protects the mRNA from exonucleases and ensures transcriptional and translational termination: stabilizes mRNA production.
- ◆ **Minimal UTR length**: UTRs contain specific characteristics that may impede transcription or translation, and thus the shortest UTRs or none at all are encoded for in optimal expression vectors.
- ◆ **Kozak sequence**: Vectors should encode for a Kozak sequence in the mRNA, which assembles the ribosome for translation of the mRNA

- The major features of a eukaryotic expression vector are a promoter, a multiple cloning site, DNA segment for termination and polyadenylation, selectable marker, origin of replication in *E. coli* and eukaryotic cell and Amp^r for marker in *E. coli*.

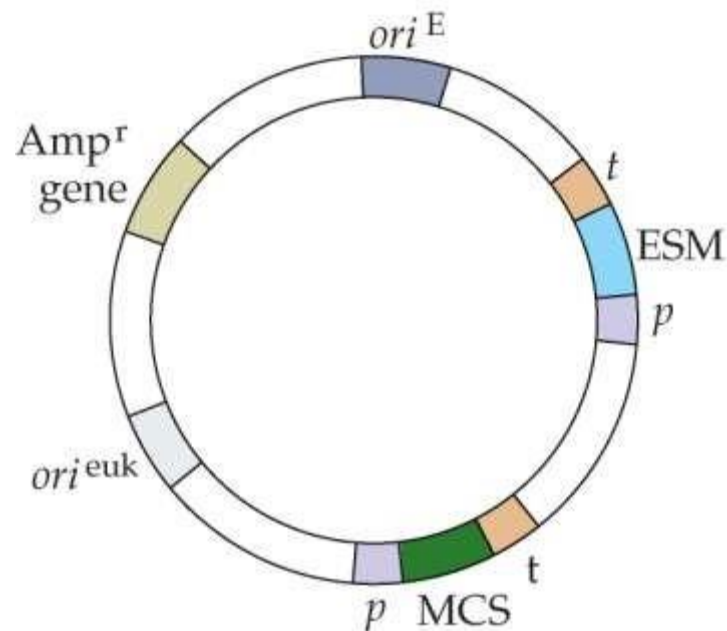

Different types of expression system:

- ◆ **Prokaryotic expression systems**
- ◆ Escherichia coli
- ◆ Lactococcus lactis
- ◆ Other bacteria, e.g. Bacillus species

- ◆ **Insect cells**
- ◆ Baculovirus
- ◆ Stable recombinant cell lines
- ◆ Schneider cells (Drosophila)
- ◆ **In vitro expression systems**
- ◆ Rabbit reticulocyte lysate (red blood cells)
- ◆ Wheat germ extract
- ◆ Escherichia coli extract

yeast

- Pichia pastoris
- Pichia methanolica
- Saccharomyces cerevisiae

mammalian cells

- Viral infection,
e.g adeno virus, retero virus ,lenti virus etc

others

- Xenopus oocytes and cell-free extract
- Transgenic mice, plants
- Milk of transgenic animals

Eukaryotic Expression Systems

- *Saccharomyces cerevisiae*
- *Pichia pastoris*
- Baculovirus-insect cell lines
- Mammalian systems

Saccharomyces cerevisiae

- It is the most common eukaryotic system and there is a great deal of study about this organism.
- It is a single-celled and behaves like a bacterial culture and can be grown in relatively simple media in both small and large-scale production.
- Well characterized with many strong regulatable promoters with naturally occurring plasmids.
- Carry out post-translational modifications.
- Secretes very few of its own proteins.
- Recognized as safe by USDA and FDA.

TABLE 7.1 Recombinant proteins produced by *S. cerevisiae* expression systems

Vaccines

Hepatitis B virus surface antigen
Malaria circumsporozoite protein
HIV-1 envelope protein

Diagnostics

Hepatitis C virus protein
HIV-1 antigens

Human therapeutic agents

Epidermal growth factor
Insulin
Insulin-like growth factor
Platelet-derived growth factor
Proinsulin
Fibroblast growth factor
Granulocyte-macrophage colony-stimulating factor
 α_1 -Antitrypsin
Blood coagulation factor XIIIa
Hirudin
Human growth factor
Human serum albumin

HIV-1, human immunodeficiency virus type 1.

Saccharomyces cerevisiae

- There are three main classes of *S. cerevisiae* expression vectors.
 - Yeast episomal plasmids (YEps).
 - Yeast integrating plasmids (YIps)
 - Yeast artificial chromosomes (YACs)
- Yeast episomal plasmids have been used extensively for the production of either intra- or extracellular heterologous proteins.
- Typically, vectors function in both *E. coli* and *S. cerevisiae*.

Saccharomyces cerevisiae

- The YEps vectors are based on the high-copy-number 2 μ m plasmids.
 - The vectors replicate independently via a single origin of replication.
 - There are more than 30 copies per cell.
 - Selection scheme rely on mutant host strains that require a particular amino acid (histidine, tryptophan, or leucine) or nucleotide (uracil).
 - When a Yep with a wild-type *LEU2* gene is transformed into a mutant *leu2* host cell, only cells that carry plasmid will grow.

- Generally, tightly regulatable, inducible promoters are preferred for producing large amounts of recombinant protein at a specific time during large-scale growth.

TABLE 7.2 Promoters for *S. cerevisiae* expression vectors

Promoter	Expression conditions	Status
Acid phosphatase (<i>PH05</i>)	Phosphate-deficient medium	Inducible medium
Alcohol dehydrogenase I (<i>ADHI</i>)	2–5% Glucose	Constitutive
Alcohol dehydrogenase II (<i>ADHII</i>)	0.1–0.2% Glucose	Inducible
Cytochrome <i>c</i> ₁ (<i>CYC1</i>)	Glucose	Repressible
Gal-1-P Glc-1-P uridyltransferase	Galactose	Inducible
Galactokinase (<i>GAL1</i>)	Galactose	Inducible
Glyceraldehyde-3-phosphate dehydrogenase (<i>GAPD</i> , <i>GAPDH</i>)	2–5% Glucose	Constitutive
Metallothionein (<i>CUP1</i>)	0.03–0.1 mM Copper	Inducible
Phosphoglycerate kinase (<i>PGK</i>)	2–5% Glucose	Constitutive
Triosephosphate isomerase (<i>TPI</i>)	2–5% Glucose	Constitutive
UDP-galactose epimerase (<i>GAL10</i>)	Galactose	Inducible

Saccharomyces cerevisiae

- Most heterologous genes are provided with a DNA coding sequence for signal peptide that facilitates the secretion of protein through cell membranes and external environment.
- Other sequence that protect the recombinant protein from proteolytic degradation, and provide a affinity tag is also used.
- These extra amino acid sequences are equipped with a protease cleavage site so that they can be removed from the recombinant protein.

Saccharomyces cerevisiae

- Plasmid-based yeast expression systems are often unstable under large-scale growth conditions even in the presence of selection pressure.
- A Yip vector is used to integrate a heterologous gene into the host genome to provide a more reliable production system.
- The plasmid does not usually carry an origin of replication.
- The disadvantage is the low yield of recombinant protein from a single gene copy.

Integration of DNA with a Yip vector

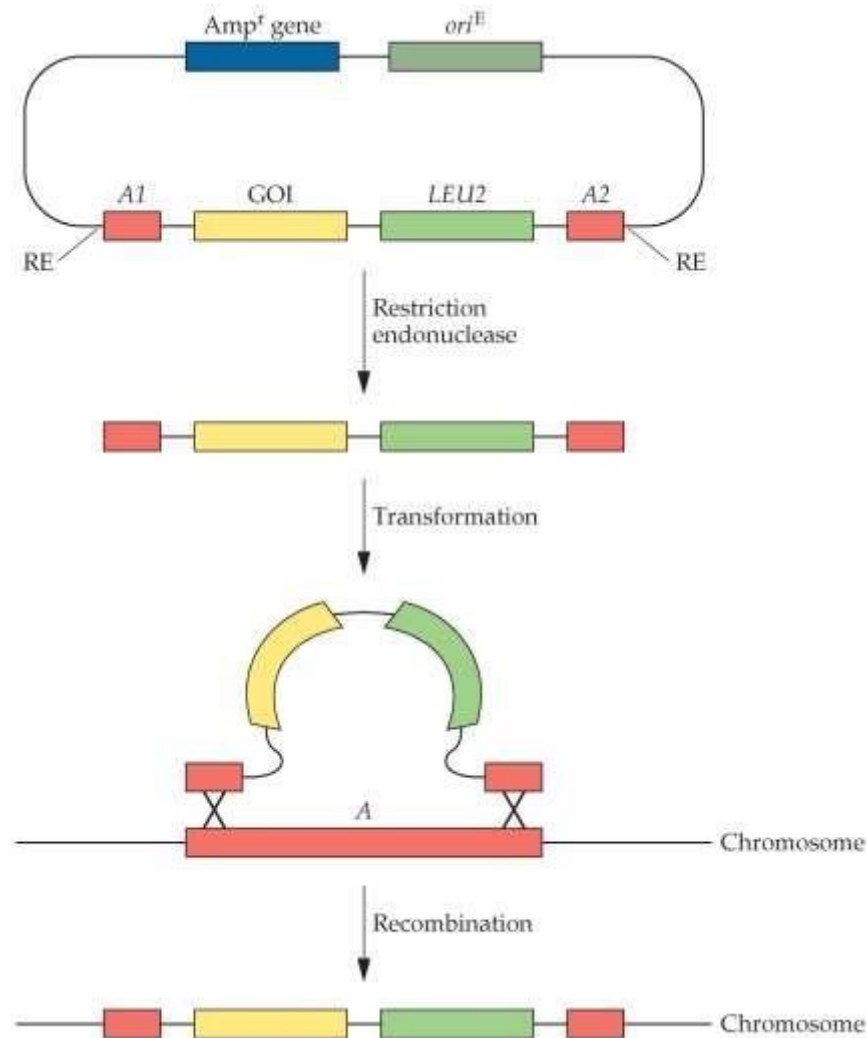

YAC cloning system

- A YAC is designed to clone a large segment of DNA (100 kb), which is then maintained as a separate chromosome in the host yeast cell.
- It is highly stable and has been used for the physical mapping of human genomic DNA, the analysis of transcription units, and genomic libraries.
- It has a sequences that act as ARS for replication, centromere for cell division, and telomere for stability.
- To date, they have not been used as expression systems for the commercial production.

YAC cloning system

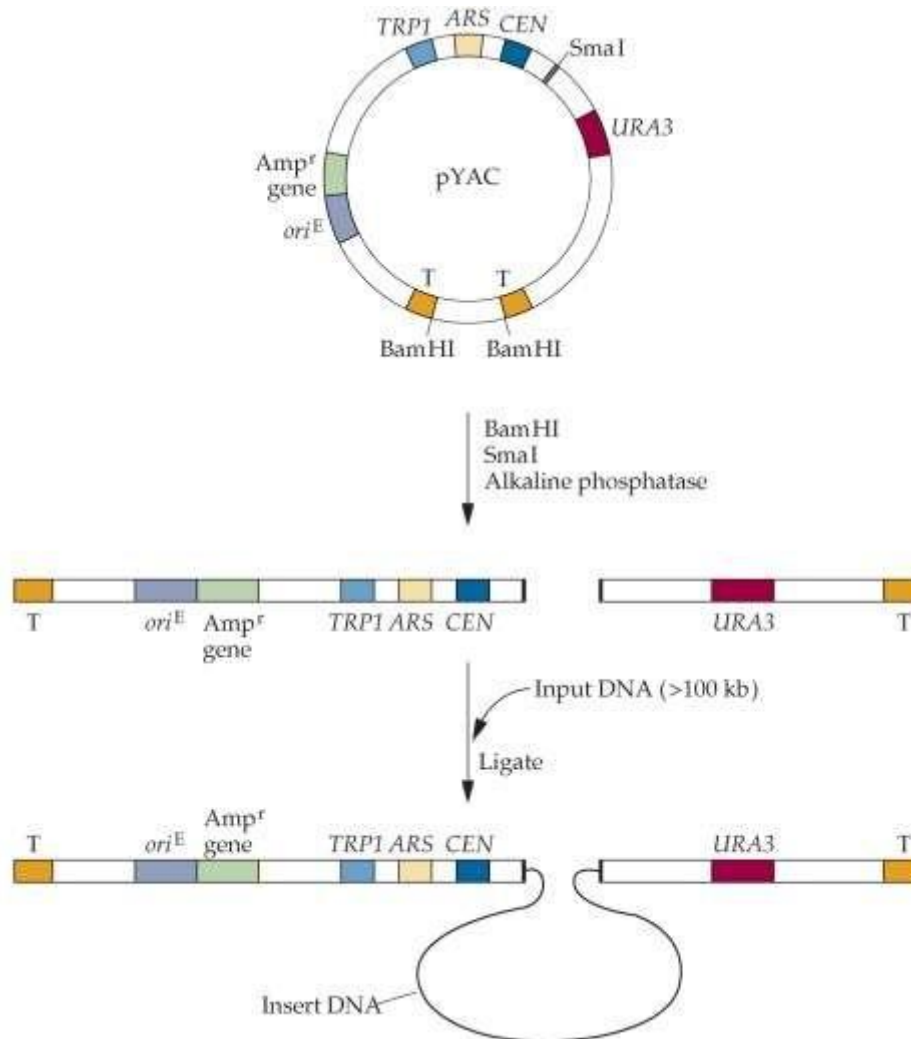

Intercellular Production in Yeast

- Human Cu/Zn SOD cDNA was cloned between the promoter and termination-polyadenylation sequence of the yeast *GAPD* gene and subsequently used to transform LEU⁻ mutant host cell.

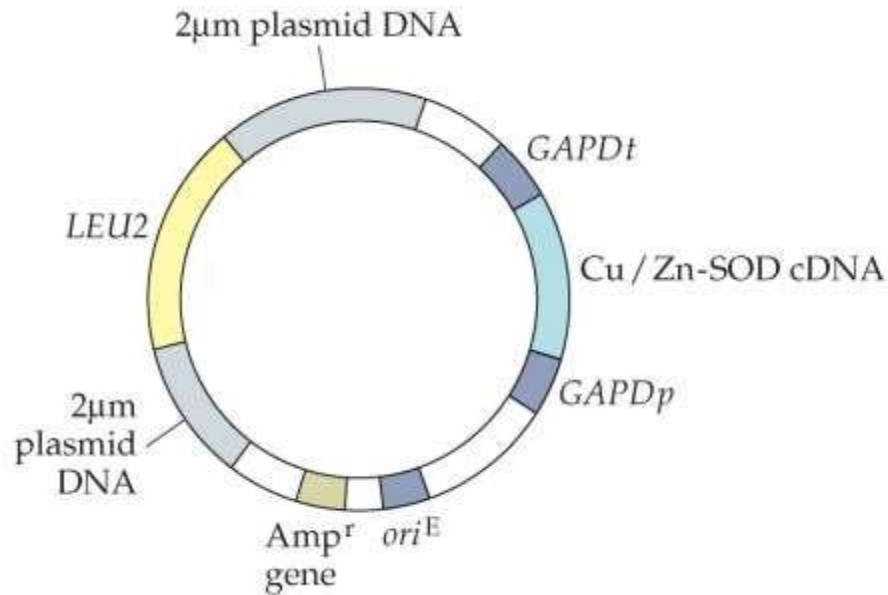

Secretion of Heterologous Proteins

- Proteins may also be produced for secretion.
- In this system, any glycosylated protein is secreted (O or N linked).
- The coding sequences of recombinant proteins must be cloned downstream of a leader sequence, the yeast mating type factor α -factor.
- Under these conditions, correct disulfide bond formation, proteolytic removal of the leader sequence, and appropriate posttranslational modifications occur, and an active recombinant protein is secreted.
- The leader peptide is removed by endoprotease that recognizes the Lys-Arg.

Secretion of Heterologous Proteins

- For example, a properly processed and active form of the protein hirudin; a powerful anticoagulant protein cloned from a leech, was synthesized and secreted by an *S. cerevisiae*.
- A YEp vector that had the prepro- α -factor sequence added to the hirudin coding sequence to allow expression that is cleaved away in processing.
- Leaves active hirudin which is secreted.
- Producing a recombinant protein for use in human therapeutics in yeast rather than in bacteria is to ensure the proper folding.

Secretion of Heterologous Proteins

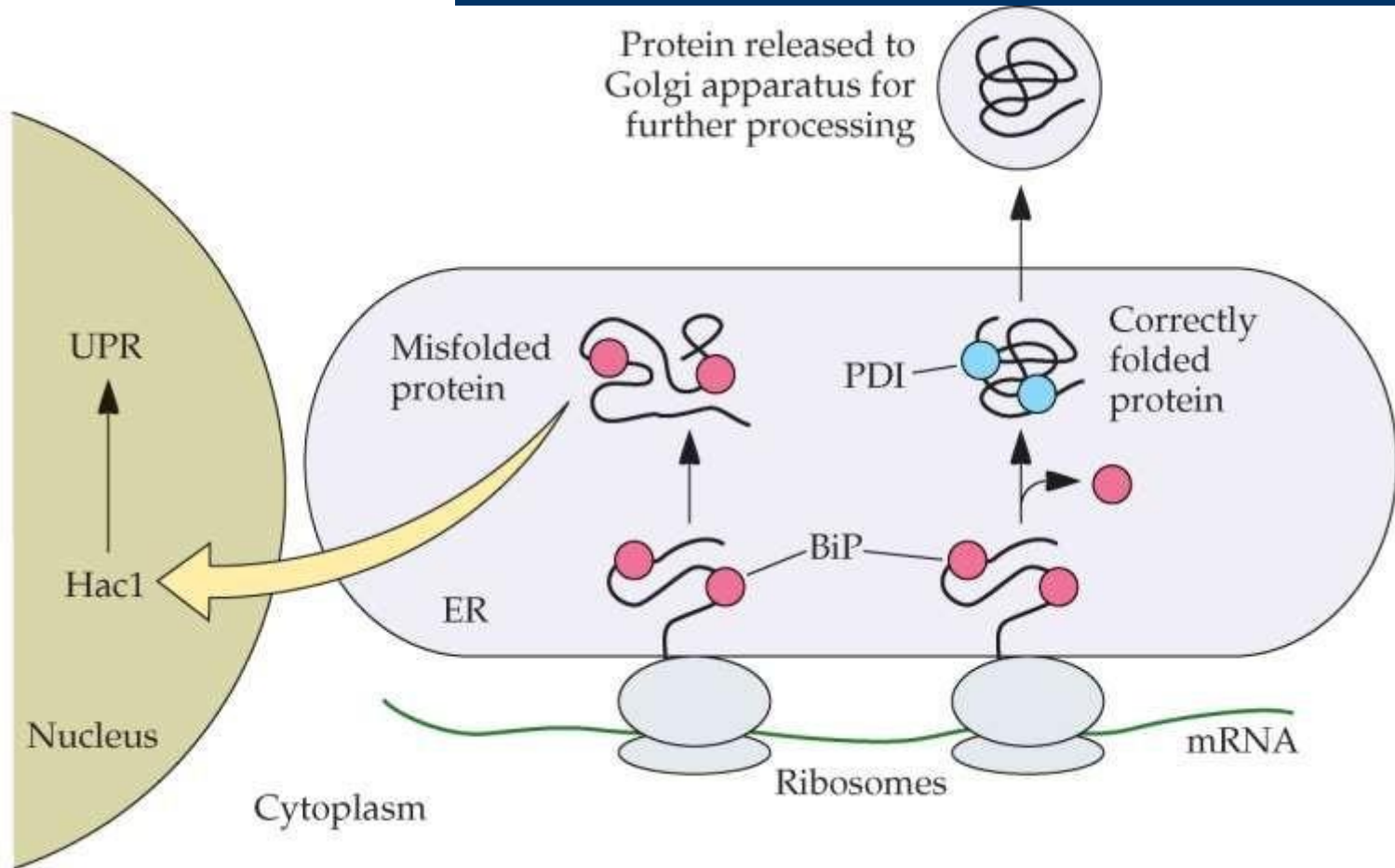

Pichia pastoris Expression Systems

- Though *S. cerevisiae* is successfully used to produce recombinant proteins for human, it has major drawbacks.
- The level of protein production is low.
- There is the tendency for hyperglycosylation resulting in change of protein function.
- Proteins are often retained in periplasm, increasing time and cost for purification.
- It produces ethanol at high cell densities, which is toxic to cells.

Pichia pastoris Expression Systems

- *P. pastoris* is a methylotrophic yeast that is able to utilize methanol as a source of carbon and energy.
- Glycosylation occurs to a lesser extent and the linkages between sugar residues are of the α -1,2 type.
- *P. pastoris* strain was extensively engineered with the aim of developing a “humanized” strain that glycosylate proteins in a manner identical to that of human cells.
- It does not produce ethanol.
- It normally secretes very few proteins, thus simplifying the purification of secreted recombinant proteins.

Pichia pastoris Expression Systems

- A double recombination event between the *AOX1p* and *AOX1* regions of the vector and the homologous segments of chromosome DNA results in the insertion of the DNA carrying the gene of interest and the *HIS4* gene.

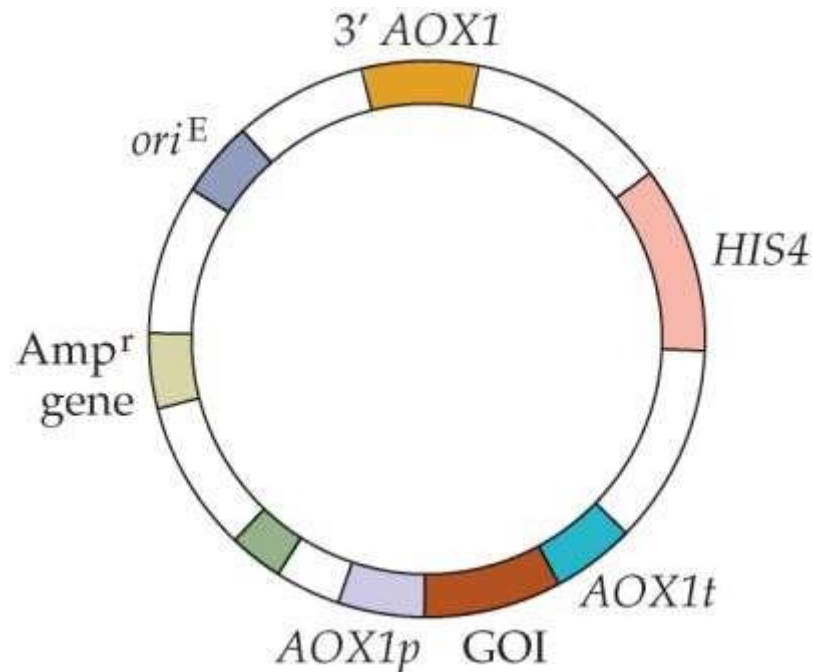

Pichia pastoris Expression Systems

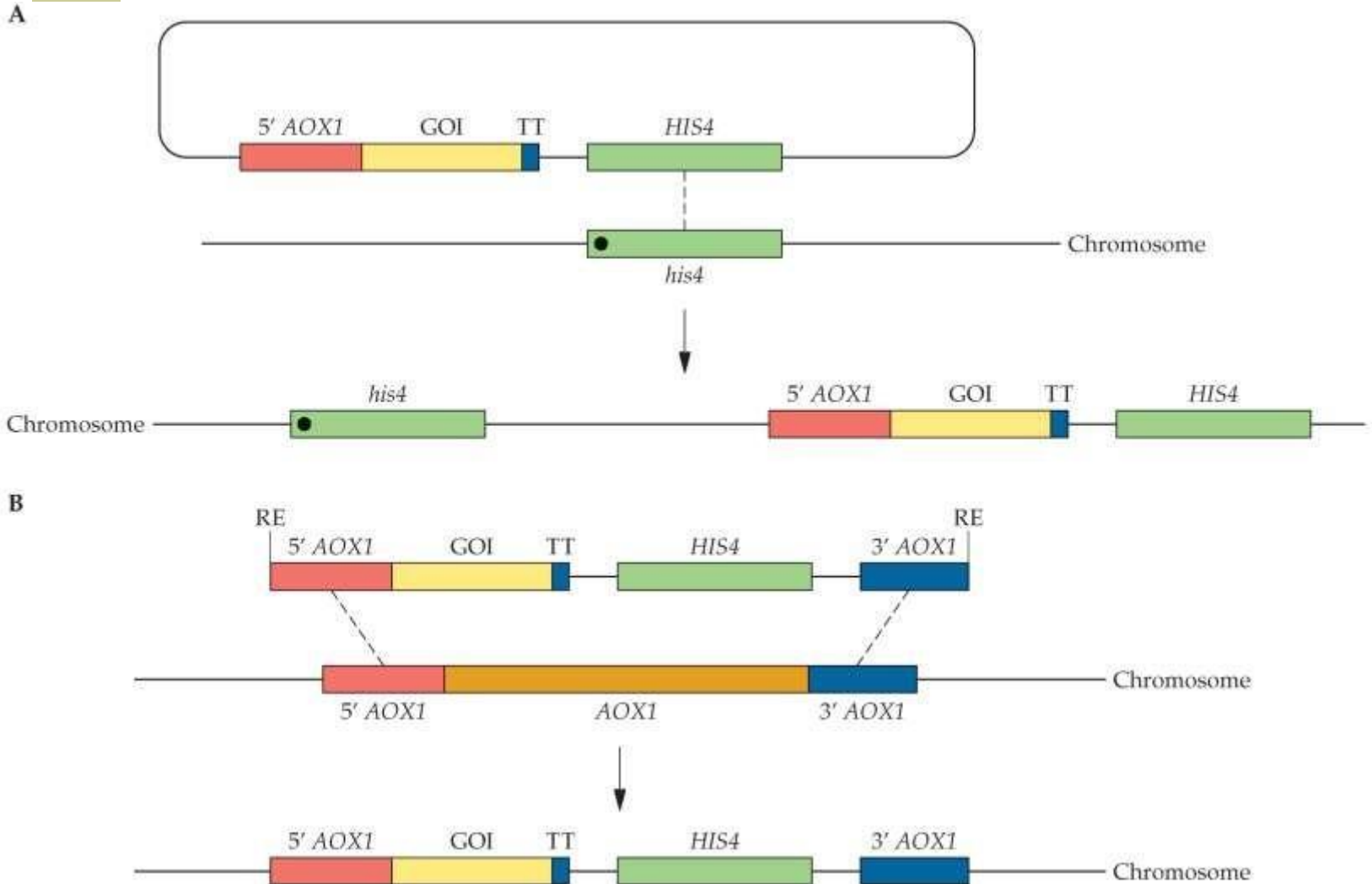

Baculovirus-Insect Cell Expression

- Baculoviruses are a large, diverse group of viruses that specifically infect arthropods, and are not infectious to other animals.
- During the infection cycle, two forms of baculovirus are produced.
 - A single nucleocapsid (virus particle) which can infect more midgut cells.
 - Clusters of nucleocapsids that are produced outside of the cells (virions) in a protein matrix (polyhedrin).

Baculovirus-Insect Cell Expression

- The polyhedrin gene is replaced with a coding sequence for a heterologous protein, followed by infection of cultured insect cells, resulting in the production of the heterologous protein.

TABLE 7.6 Some of the recombinant proteins that have been produced by the baculovirus expression vector system

α -Interferon	G-protein-coupled receptors	Malaria proteins
Adenosine deaminase	HIV-1 envelope protein	Mouse monoclonal antibodies
Anthrax antigen	HSV capsid proteins	Multidrug transporter protein
β -Amyloid precursor protein	Human alkaline phosphatase	Poliovirus proteins
β -Interferon	Human DNA polymerase α	Pseudorabies virus glycoprotein 50
Bovine rhodopsin	Human pancreatic lipase	Rabies virus glycoprotein
Cystic fibrosis transmembrane conductance regulator	Influenza virus hemagglutinin	Respiratory syncytial virus antigen
Dengue virus type 1 antigen	Interleukin-2	Simian rotavirus capsid antigen
Erythropoietin	Lassa virus protein	Tissue plasminogen activator

HIV-1, human immunodeficiency virus type 1; HSV, herpes simplex virus.

Baculovirus-Insect Cell Expression

- Constructs have been made using the polyhedrin promoter to produce large quantities of extracellular protein.
- Most proteins are modified and secreted properly.
- Grows very well in many insect cell lines allowing easy production.
- Minor problem that doesn't process certain mammalian glycosylation types correctly (galactose and sialic acid; N-linked.)

Baculovirus Expression Vectors

- The specific baculovirus that has been used extensively is *Autographa californica* multiple nuclear polyhedrosis virus (AcMNPV.)
- A gene of interest is inserted into the MCS and the transfer vector is propagated in *E. coli*.
- Next, insect cells in culture are cotransfected with AcMNPV DNA and the transfer vector carrying the cloned gene.

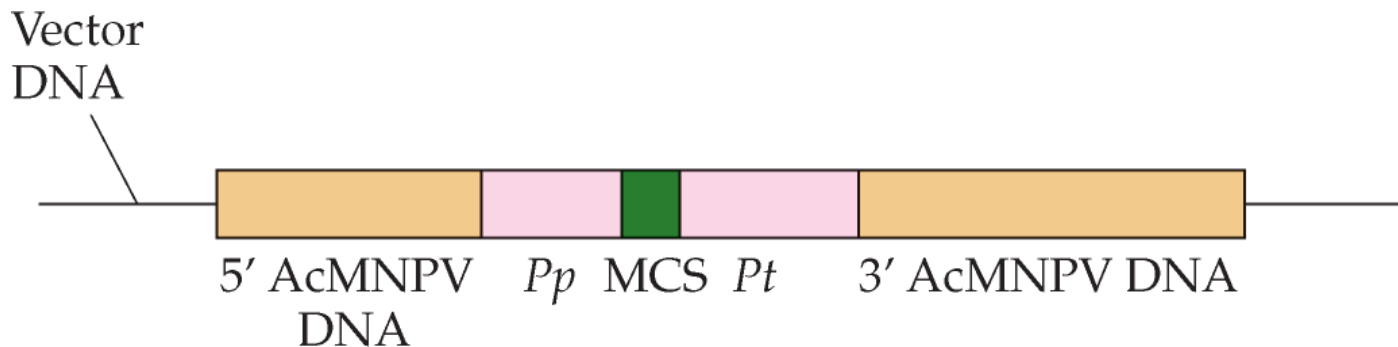

Baculovirus Expression Vectors

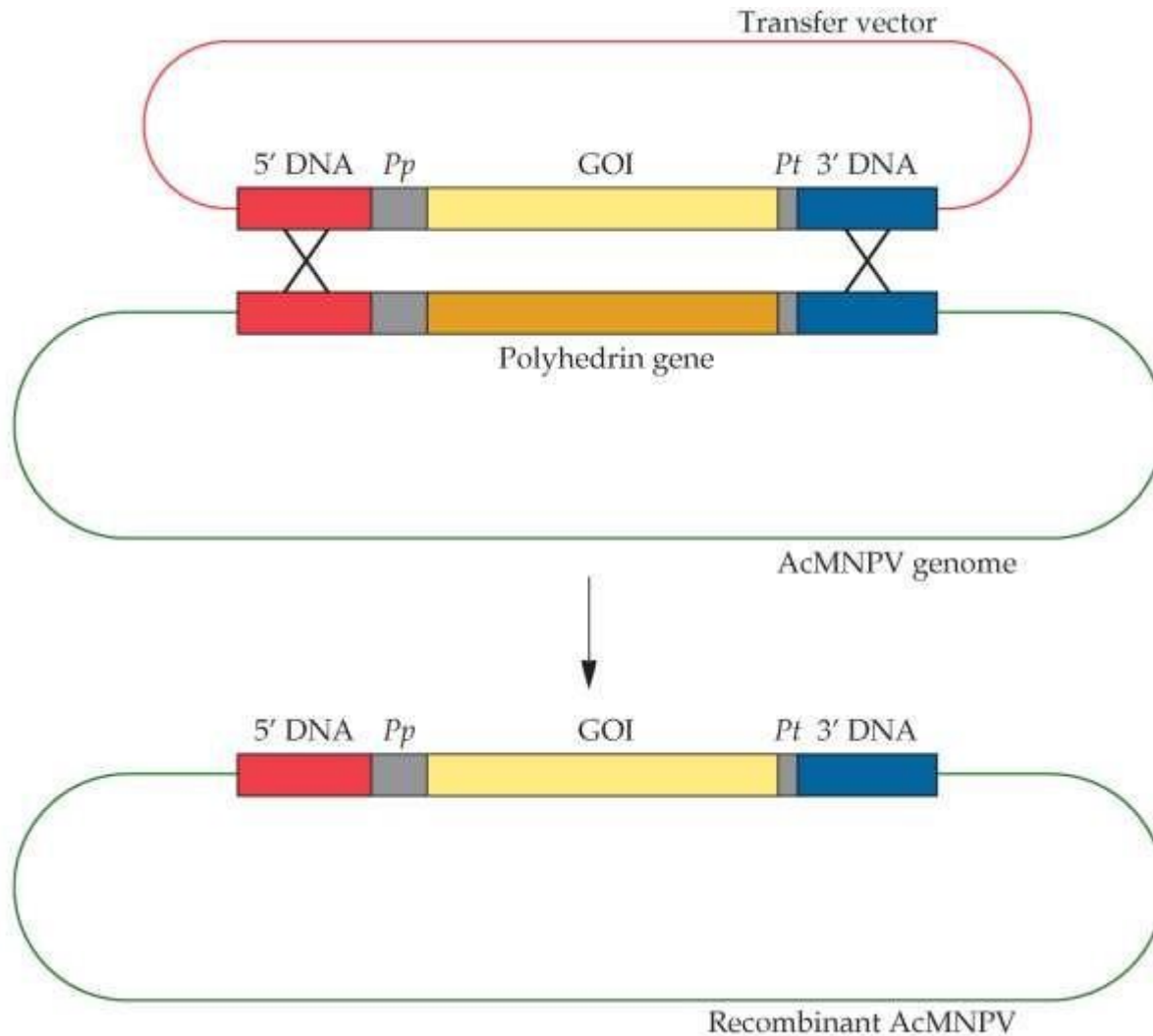

Increasing the Yield of Recombinant Baculovirus

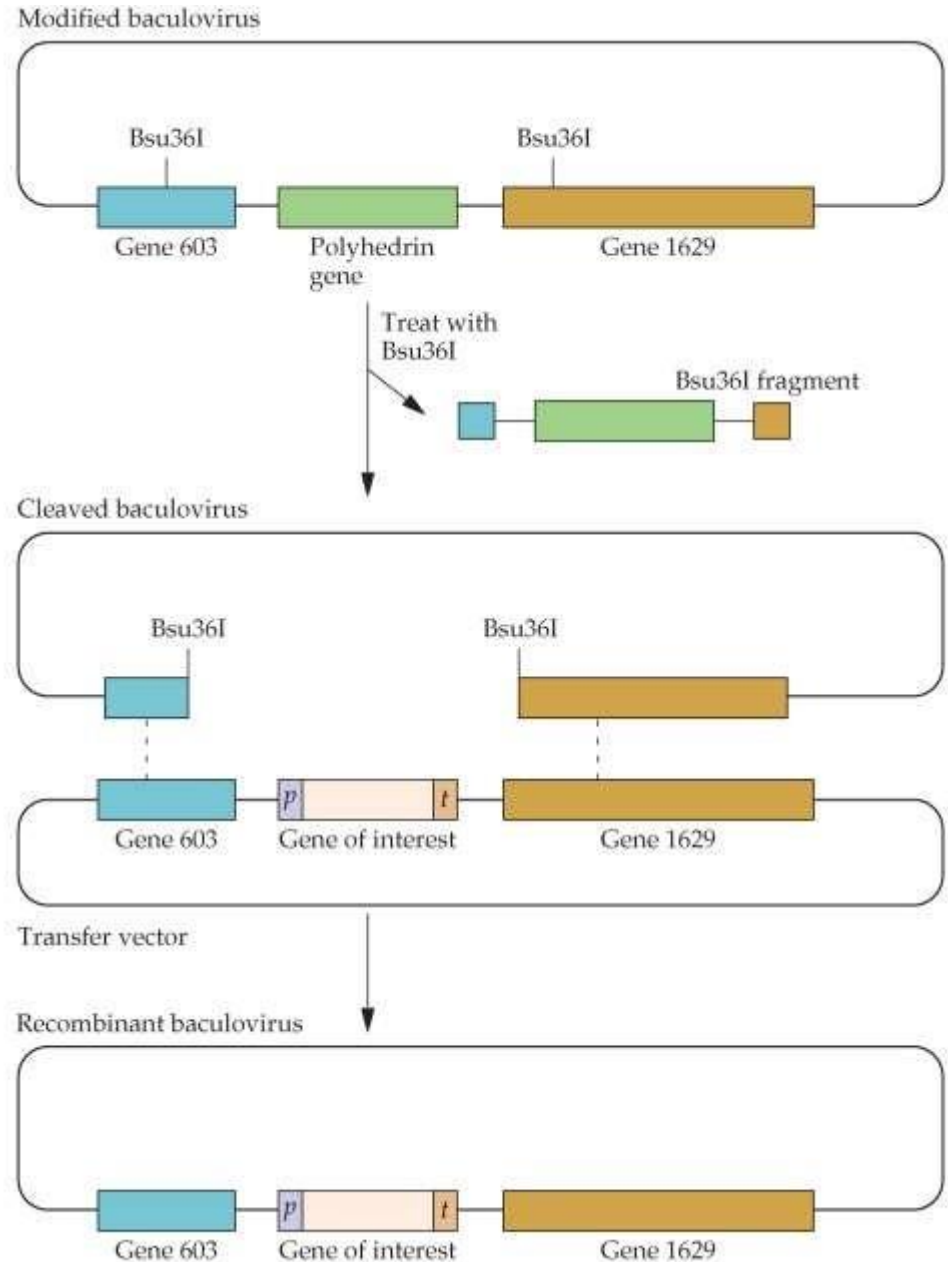

Mammalian Cell Expression Systems

- Important for producing proteins with all post-translational modifications.
- Many established cell lines are useful.
- Transient expression: African green monkey, baby hamster, & human embryonic (all kidney tissue cell lines.)
- Long-term expression: Chinese hamster ovary and mouse myeloma cells.

Mammalian Cell Expression Systems

- Expression vectors in these systems are usually derived from an animal virus such as SV40 (simian virus 40).
- Can be used for expression of single polypeptides, homooligomers, and heterooligomers.
- The latter is made possible by transforming with two or more separate cloned genes.
- Industrial production is however costly.

Vector Design

- Generalized mammalian expression vector.
- The MCS and SMG are under the control of eukaryotic promoter, polyadenylation, and terminal sequence.
- An intron enhances the production of heterologous protein.
- The Amp^r gene is used for selecting transformed *E. coli*.

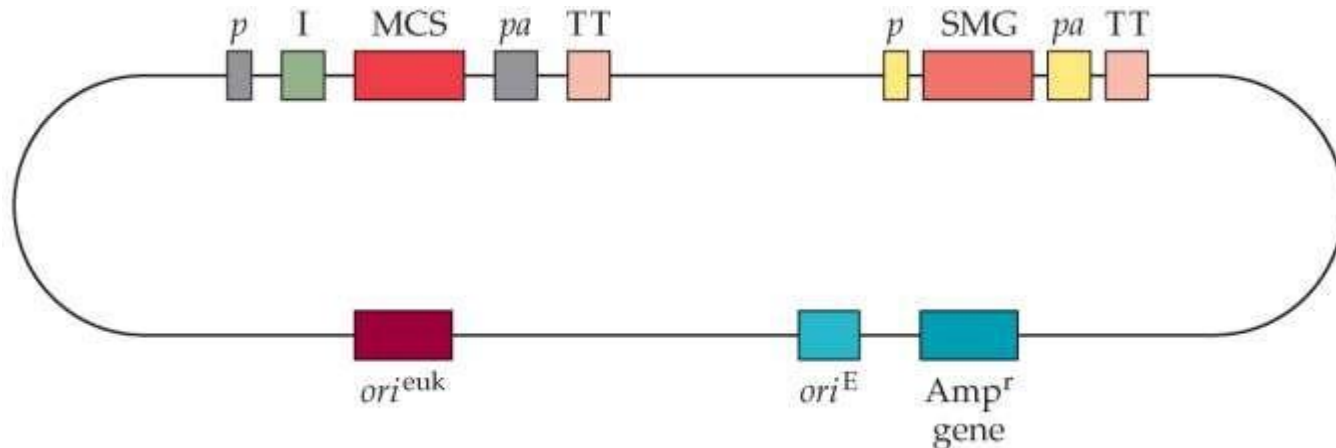

- For the best results, a gene of interest must be equipped with translation control sequences.
- A gene of interest can be fitted with various sequences that enhance translation and facilitate both secretion and purification.
- A Kozak sequence, specific sequence surrounding the AUG start codon, signal sequence, protein affinity tag for purification, proteolytic cleavage site, and stop codon.
- The 5' and 3' UTR increase the efficiency of translation and contribute to mRNA stability.



Two-Vector Expression System

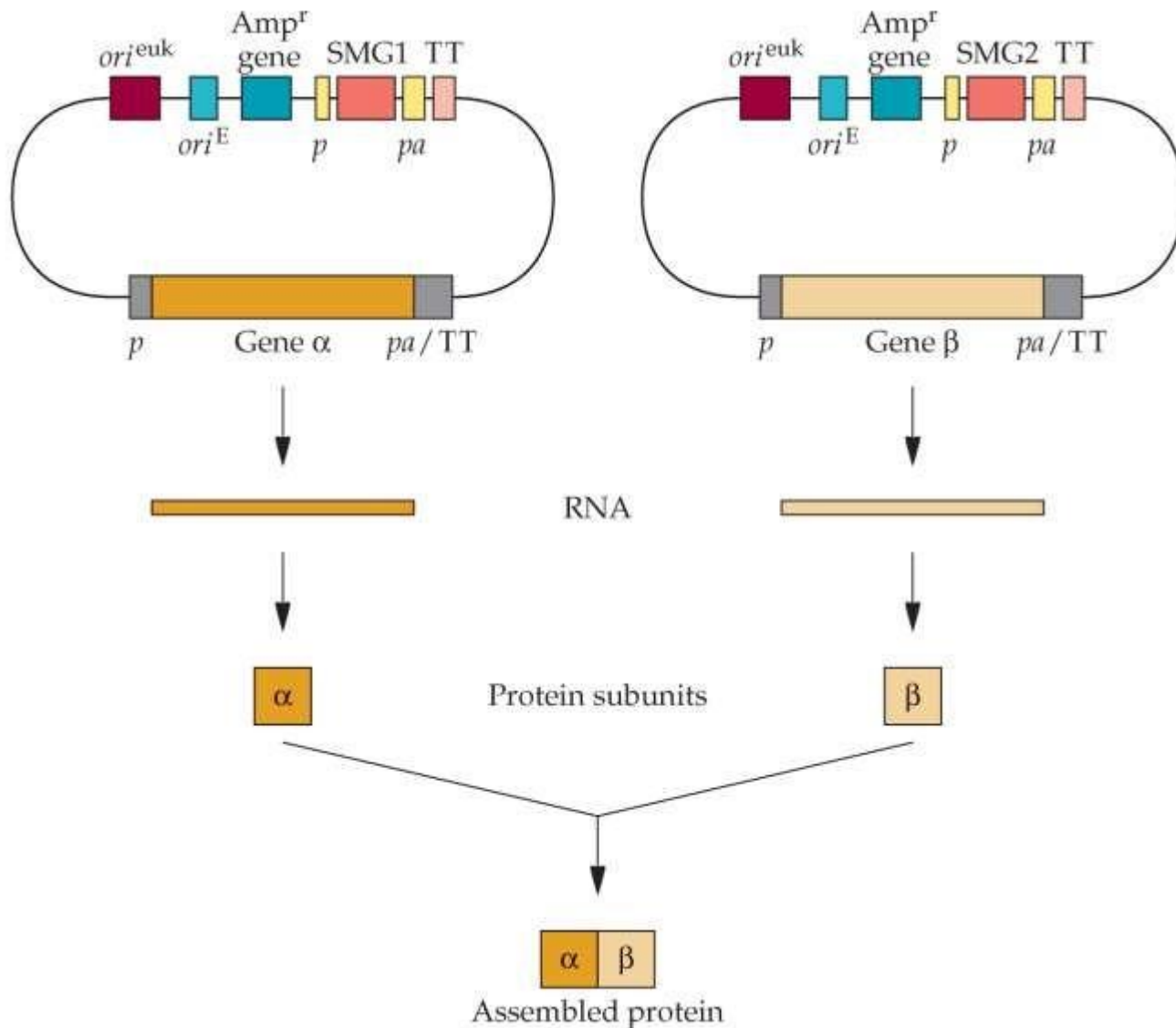

Two-Vector Expression System

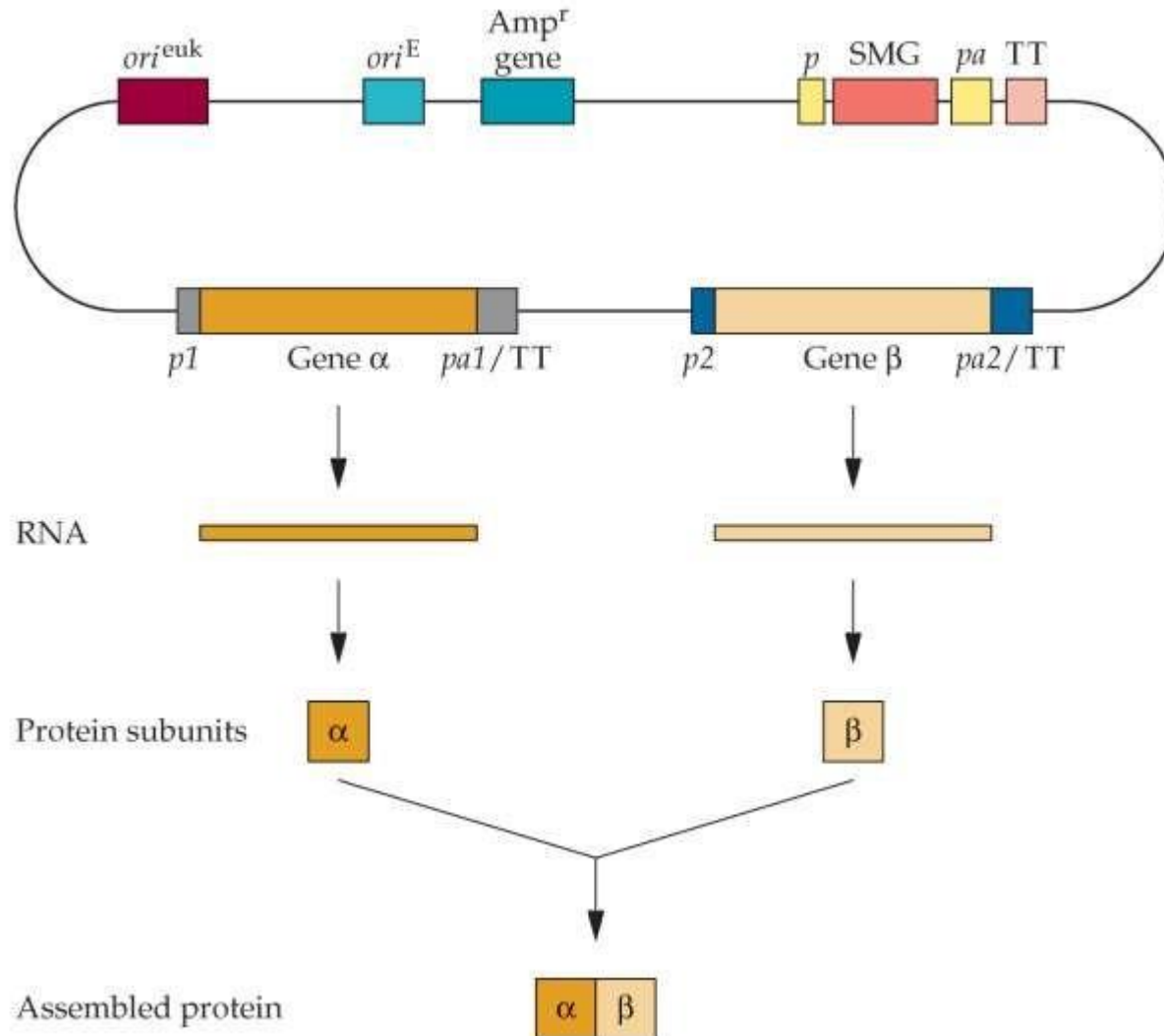

Baculovirus Vector in Mammalian Cells

- It is possible to use some of the baculovirus vector to express target proteins in mammalian cells
- Because baculovirus cannot replicate in mammalian cells and the polyhedron-deficient strains employed as vectors cannot infect insects. It is a safe system.
- For stable long-term expression, the target gene is inserted between sequences for adeno-associated virus inverted terminal repeat to facilitate the integration into the host cells.

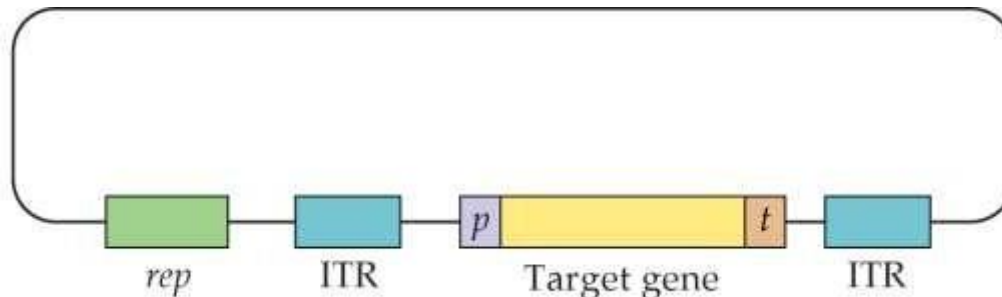

Selectable Markers for mammalian Expression Vectors

TABLE 7.7 Selective marker gene systems for mammalian cells

Selective agent	Action of selective agent	Marker gene	Action of marker gene protein
Xyl-A	Damages DNA	Adenine deaminase (<i>ada</i>)	Deaminates Xyl-A
Blasticidin S	Inhibits protein synthesis	Blasticidin S deaminases (<i>Bsr</i> , <i>BSD</i>)	Deaminates blasticidin S
Bleomycin	Breaks DNA strands	Bleomycin-binding protein (<i>Ble</i>)	Binds to bleomycin
G-418 (Geneticin)	Inhibits protein synthesis	Neomycin phosphotransferase (<i>neo</i>)	Phosphorylates G-418
Histidinol	Produces cytotoxic effects	Histidinol dehydrogenase (<i>hisD</i>)	Oxidizes histidinol to histidine
Hygromycin B	Inhibits protein synthesis	Hygromycin B phosphotransferase (<i>Hph</i>)	Phosphorylates hygromycin B
MSX	Inhibits glutamine synthesis	Glutamine synthetase (<i>GS</i>)	Cells that produce excess glutamine synthetase survive.
MTX	Inhibits DNA synthesis	Dihydrofolate reductase (<i>dhfr</i>)	Cells that produce excess dihydrofolate reductase survive.
PALA	Inhibits purine synthesis	Cytosine deaminase (<i>codA</i>)	Lowers cytosine levels in the medium by converting cytosine to uracil
Puromycin	Inhibits protein synthesis	Puromycin <i>N</i> -acetyltransferase (<i>Pac</i>)	Acetylates puromycin

MSX, methionine sulfoximine; MTX, methotrexate; PALA, *N*-(phosphoacetyl)-L-aspartate; Xyl-A, 9- β -D-xylofuranosyl adenine.



Thank You