

EXTRAOCULAR MUSCLES

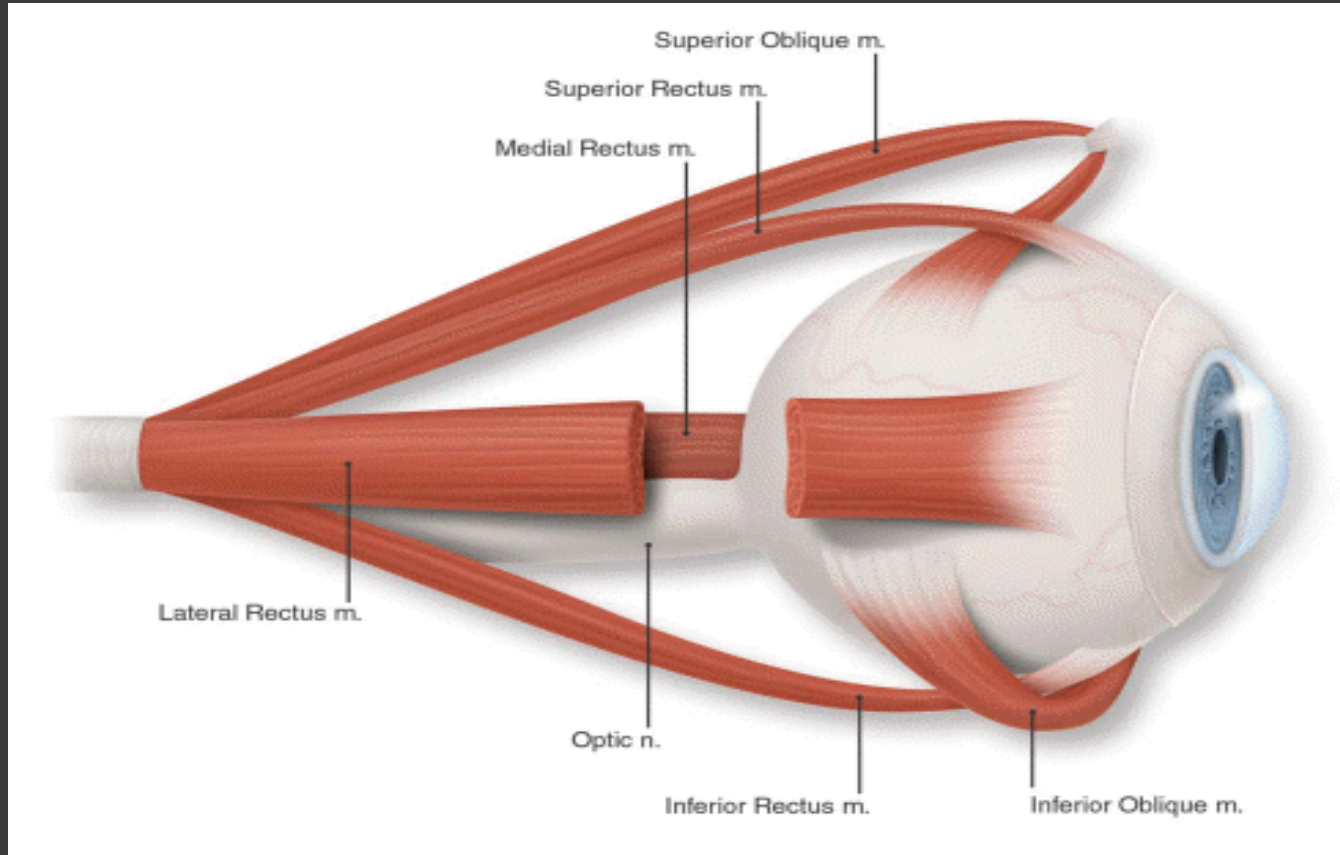

ORBITAL MUSCLES

INTRA-
OCULAR

EXTRA-
OCULAR

CILIARY
MUSCLES

INVOLUNTARY

VOLUNTARY

1. Superior tarsal muscle.
2. Inferior tarsal muscle

1. Levator Palpebrae Superioris
2. Superior rectus
3. Inferior rectus
4. Medial rectus
5. Lateral rectus
6. Superior oblique
7. Inferior oblique

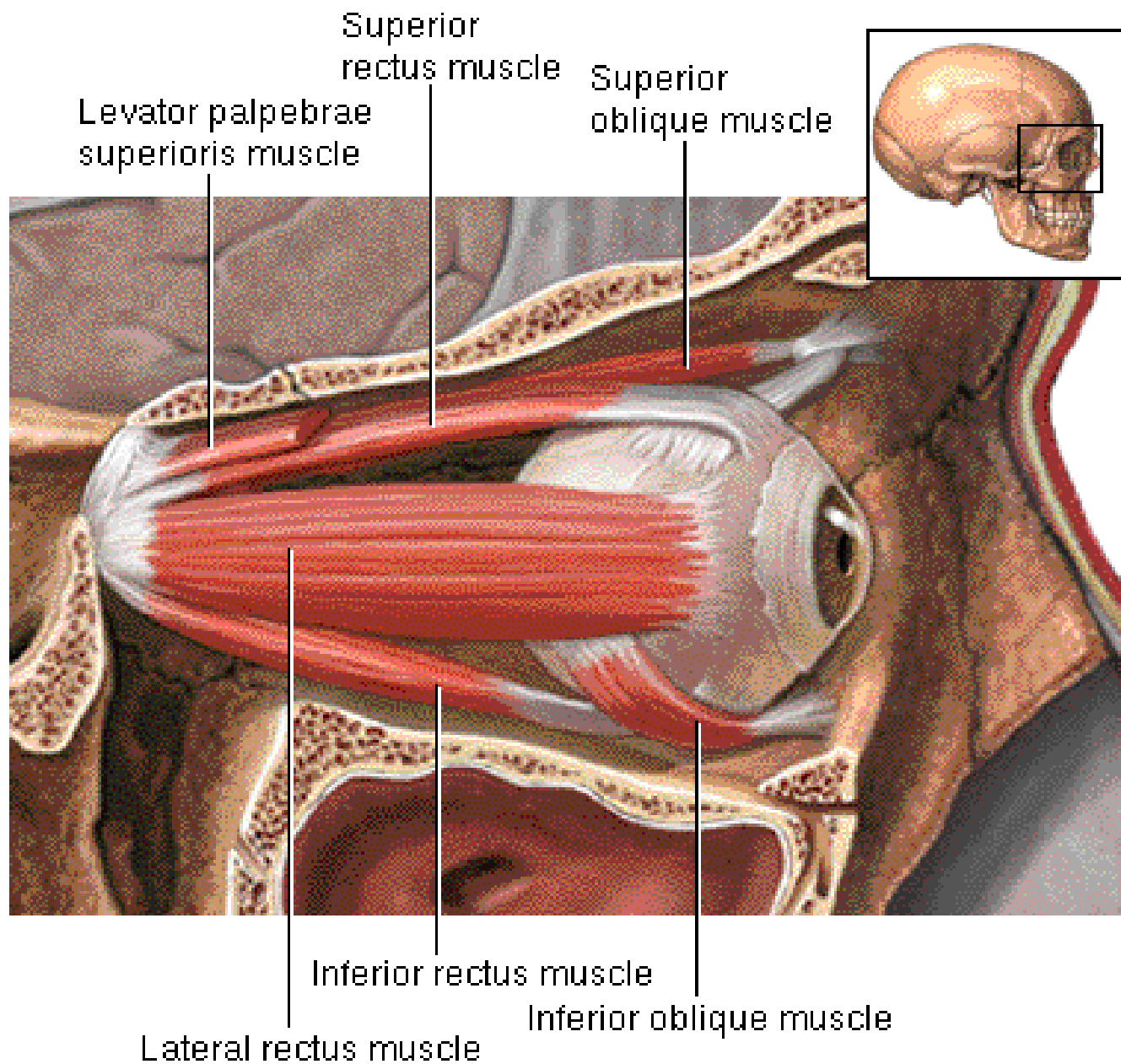

LEVATOR PALPEBRAE SUPERIORIOS

Origin-

Inferior surface of lesser wing of sphenoid.

Insertion-

- Upper lamina (Voluntary) - Anterior surface of superior tarsus & skin of upper eyelid.
- Middle lamina (Involuntary) - Superior margin of superior tarsus.
(Superior Tarsus Muscle / Muller muscle)
- Lower lamina (Involuntary) - Superior conjunctival fornix

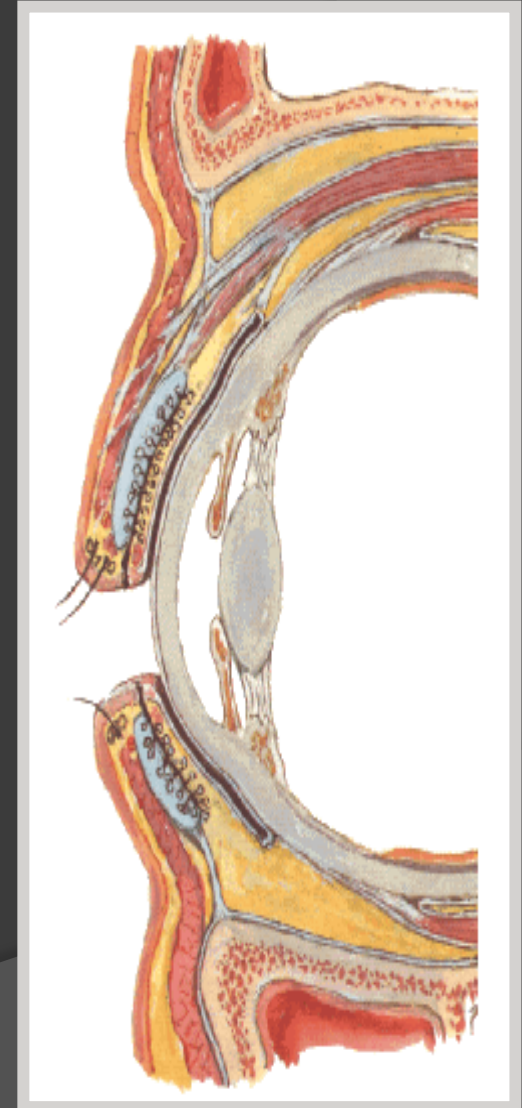

Nerve Supply :-

- ⦿ Voluntary part – Oculomotor Nerve
- ⦿ Involuntary part – Sympathetic

ACTION :- Elevation of upper eye lid

C/S :- Drooping of upper eyelid.

- ⦿ Congenital ptosis due to localized myogenic dysgenesis
- ⦿ Complete ptosis - Injury to oculomotor nerve.
- ⦿ Partial ptosis - disruption of postganglionic sympathetic fibres from superior cervical sympathetic ganglion.



Extra ocular Muscles : Origin

Levator palpebrae superioris

Superior Oblique

Superior Rectus

Lateral Rectus

Medial Rectus

Inferior Rectus

Inferior Oblique

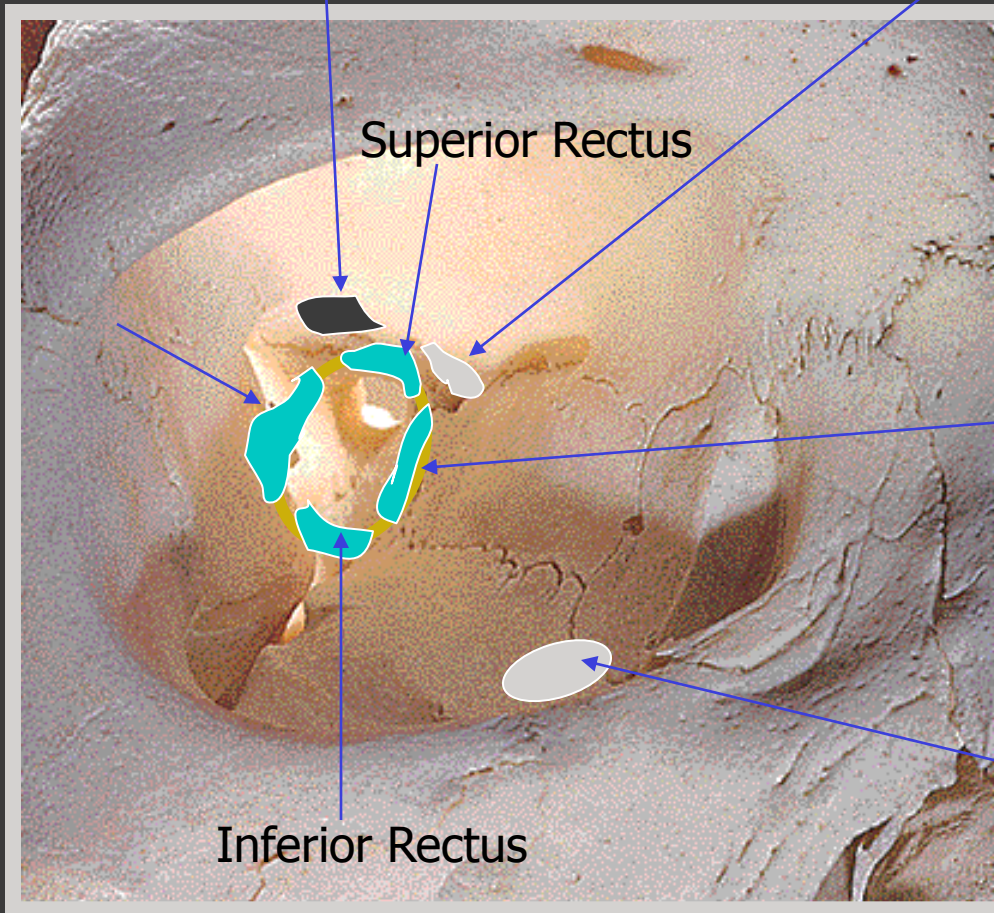

RECTUS MUSCLES : ORIGIN

- Arises from a common tendinous ring known as ANNULUS OF ZINN
- Common ring of connective tissue
- Anterior to optic foramen
- Forms a muscle cone

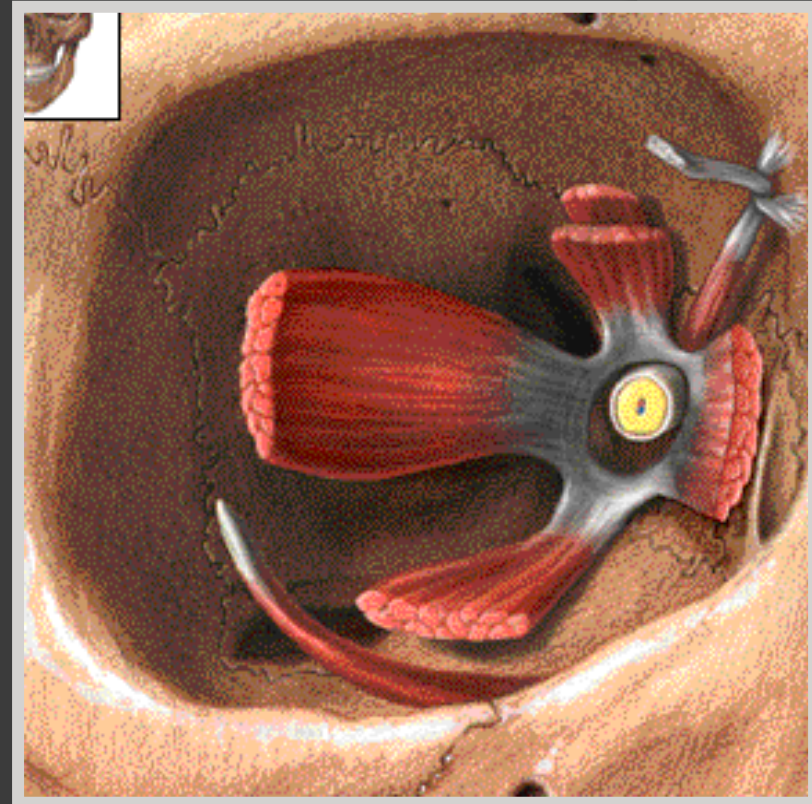

Clinical Significance

⦿ Retrobulbar neuritis

- Origin of SUPERIOR AND MEDIAL RECTUS are closely attached to the dural sheath of the optic nerve, which leads to pain during upward & inward movements of the globe.

⦿ Thyroid orbitopathy

- Medial & Inf.rectus thicken. especially near the orbital apex
- compression of the optic nerve as it enters the optic canal adjacent to the body of the sphenoid bone.

⦿ Ophthalmoplegia

- Proptosis occur due to muscle laxity.

Medial Rectus

Origin :- Annulus of Zinn (upper & Lower limb of common tendinous sheath)

Insertion :- Sclera , 5.3 mm away from limbus

Fascial expansion from muscle sheath forms the medial check ligament and attach to medial wall of orbit

B/S :- Medial muscular Art. Branch of cerebral part of IC + lacrimal art.

N/S :- 3rd CN Nrv.

Superior Rectus

Origin :- Superior limb of the tendinous ring, and optic nerve sheath.

Insertion :- Sclera 7.7 mm away from limbus obliquely making an angle of 23 d with saggital axis.

(Expansion of the SR is attached to the LPS. Thus when the SR makes the eye look up ,the upper lid is also raised.)

B/S :- Lateral Muscular Art. Branch of cerebral part of IC

N/S :- 3rd CN Nrv.

*Separated from roof by LPS

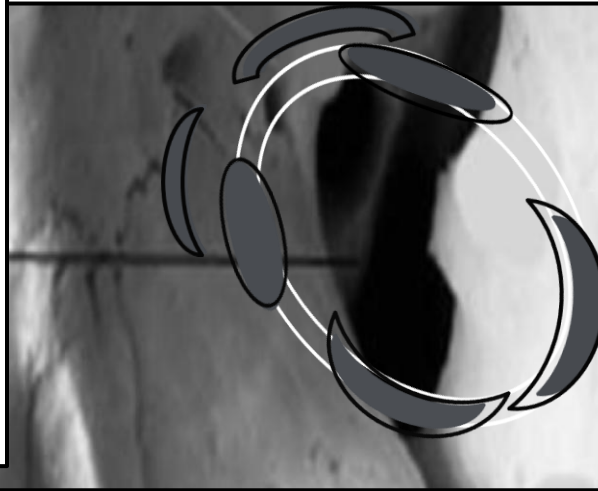

Lateral Rectus

Origin :- Upper and lower limb of Annulus of Zinn, AND a process of the greater wing of the sphenoid bone.

Insertion :- Sclera , 6.9 mm away from limbus.

Fascial expansion from muscle sheath forms the lateral check ligament and attach to lateral wall of orbit at Whitnalls tubercle

B/S :- Lateral Muscular Art. Branch of cerebral part of IC

N/S :- 6th CN Nrv.

Inferior Rectus

Origin :- Annulus of Zinn

Insertion :- Sclera ,6.8 mm away from limbus

B/S :- Medial Muscular Art. Branch of cerebral part of IC

N/S :- 3rd CN Nrv.

BLOOD SUPPLY

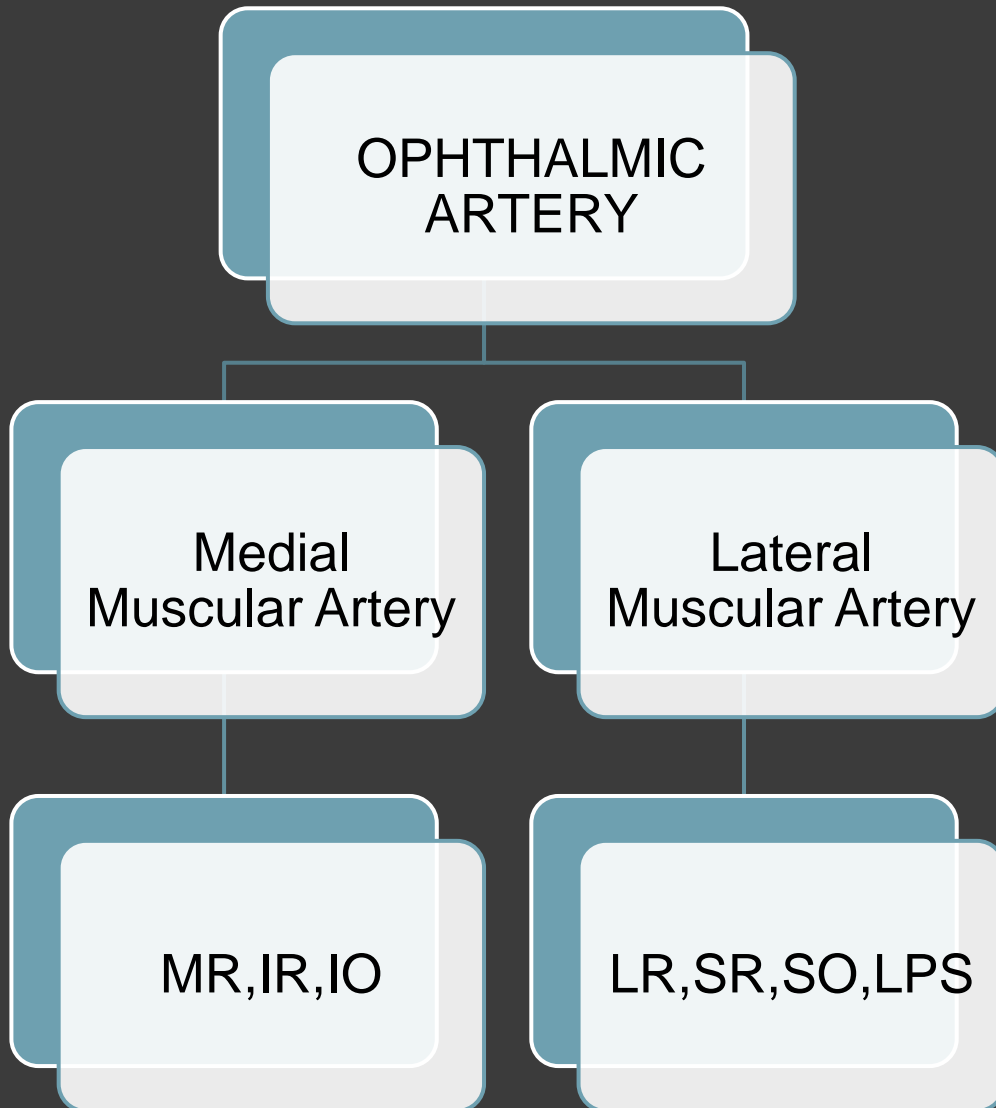

- Additional Ciliary arteries also arise from these muscular arteries
- Seven branches
- Two for each recti except lateral rectus which receives only one branch

SPIRAL OF TILLAUX

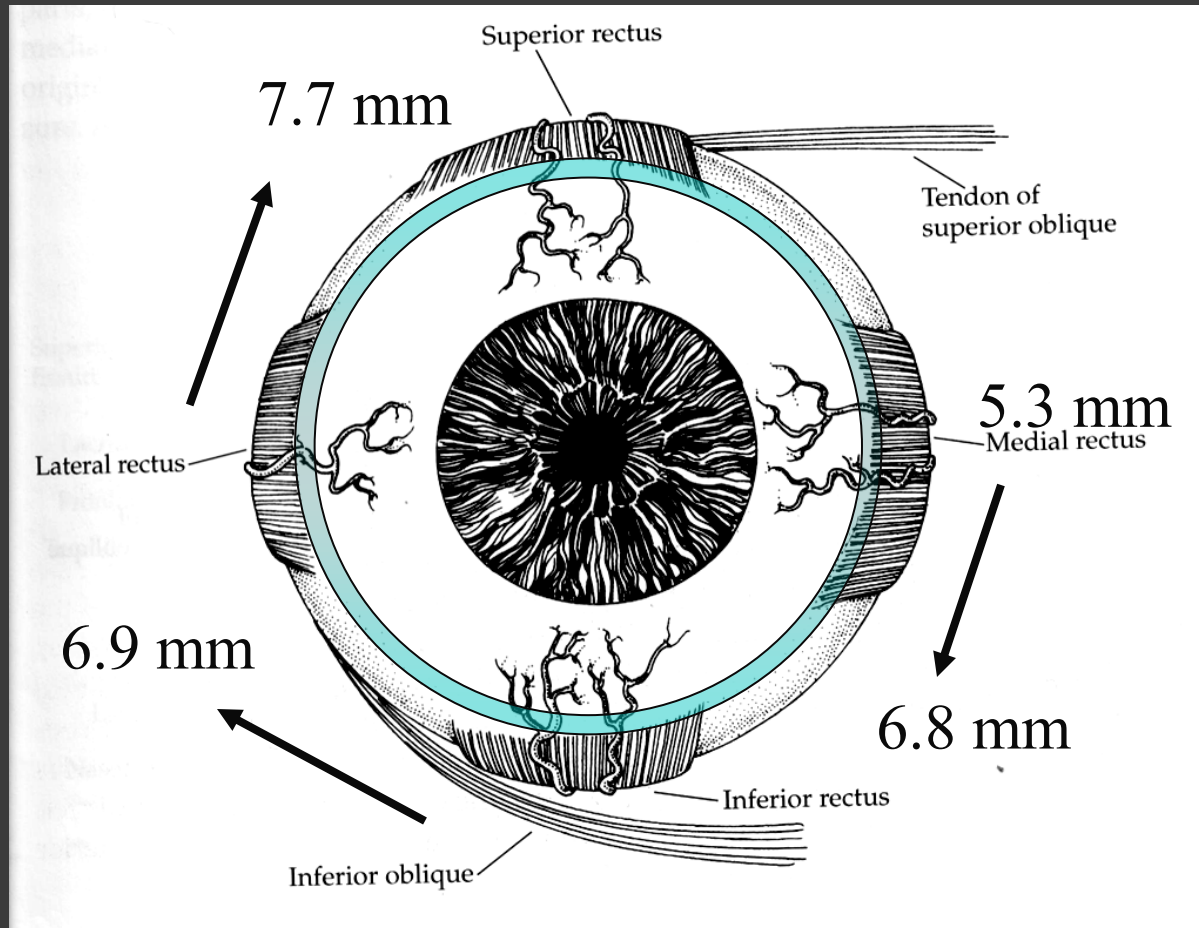

- Medial rectus inserts closest to the limbus and is therefore susceptible to injury during ant. segment surgery.
- Inadvertent removal of the MR is a well known complication of Pterygium removal
- The Scleral thickness behind the rectus insertion is the thinnest, being only 0.3 mm thick -> chances of scleral perforation while suturing

SUPERIOR ORBITAL FISSURE SYNDROME

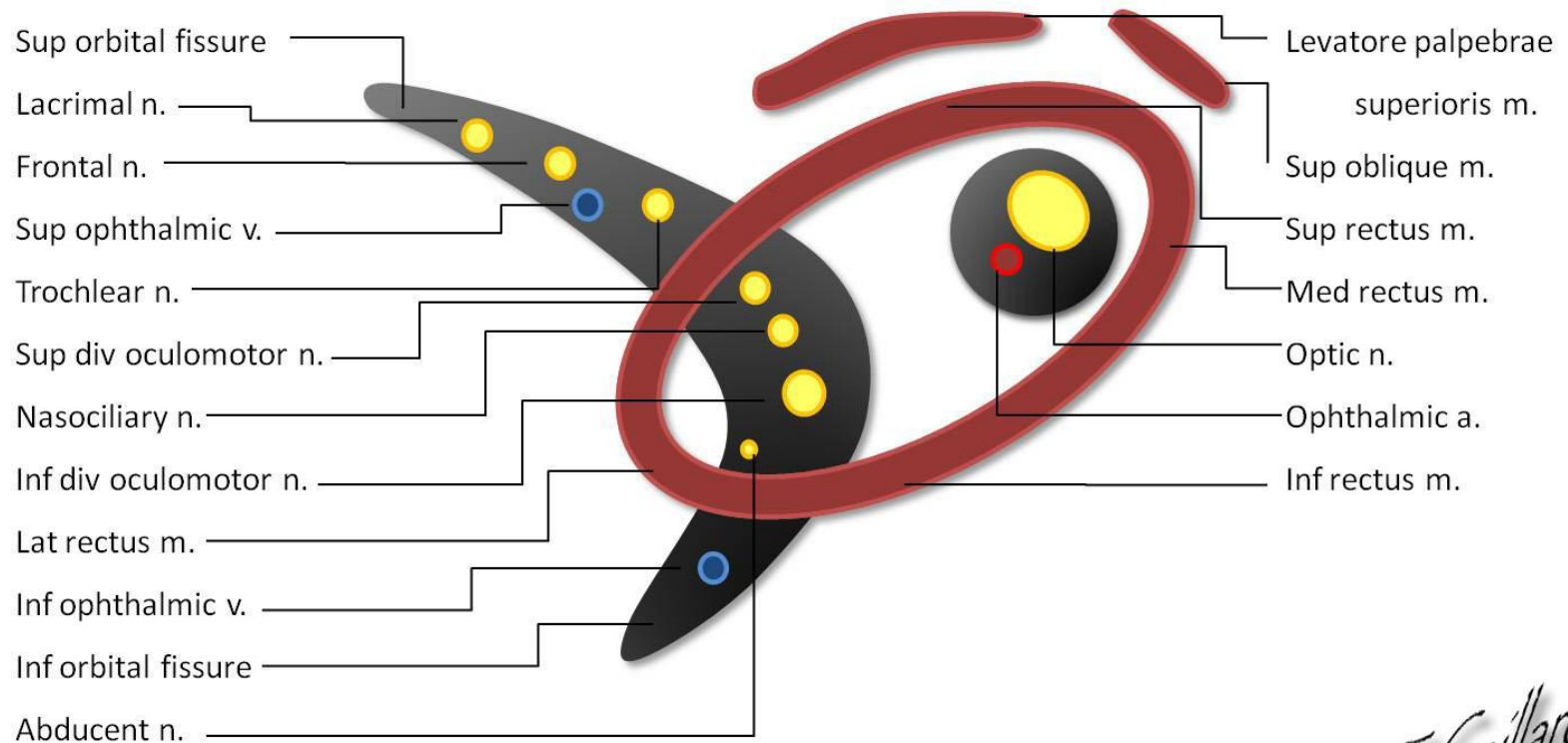

*FGaillard
2007*

SUPERIOR OBLIQUE

Origin

Anatomical origin :- Lesser wing of the sphenoid bone.

Physiological origin is the trochlea, a cartilagenous “U” on the superior medial wall of the orbit

Insertion: The insertion line is curved with its concavity facing the trochlea.

Ant. end lies 12 to 14 mm behind the limbus

Post. end lies 17 to 19 mm behind the limbus

B/S: Lateral muscular Art.

N/S: 4th CN Nerve.

- Longest and thinnest EOM

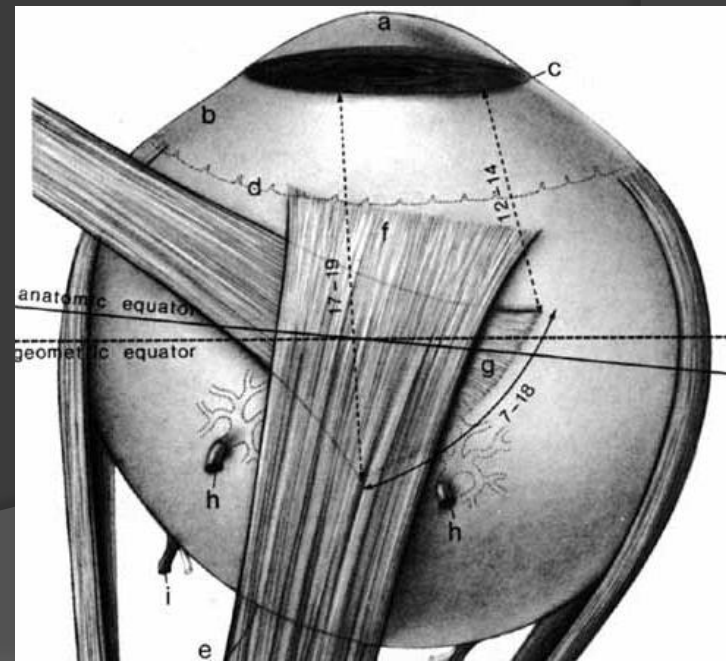
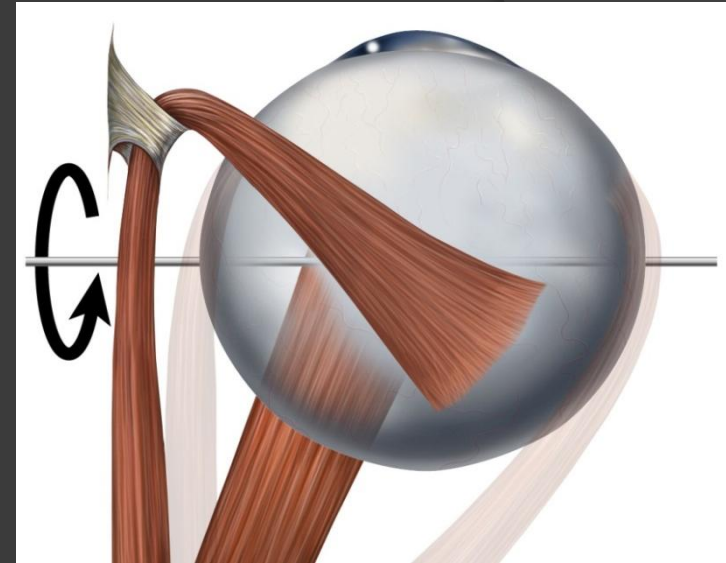

INFERIOR OBLIQUE

Origin

- From a shallow depression on the orbital plate of maxilla
- Just lateral to the lacrimal sac
- The ONLY EOM originating in the anterior orbit.

Insertion

- Lower and outer part of sclera behind the equator

B/S: Medial Muscular Art.

N/S Oculomotor nerve – inferior division

- Fibres travel along the pupillary fibres in the inferior division of oculomotor nerve

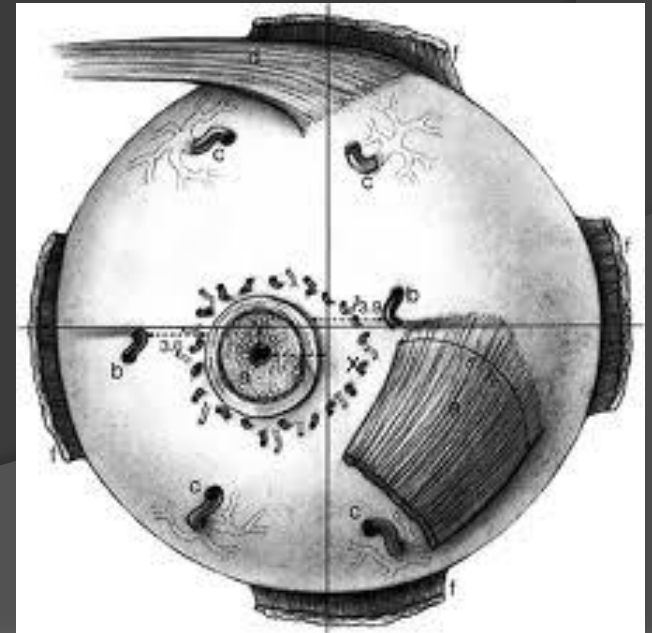
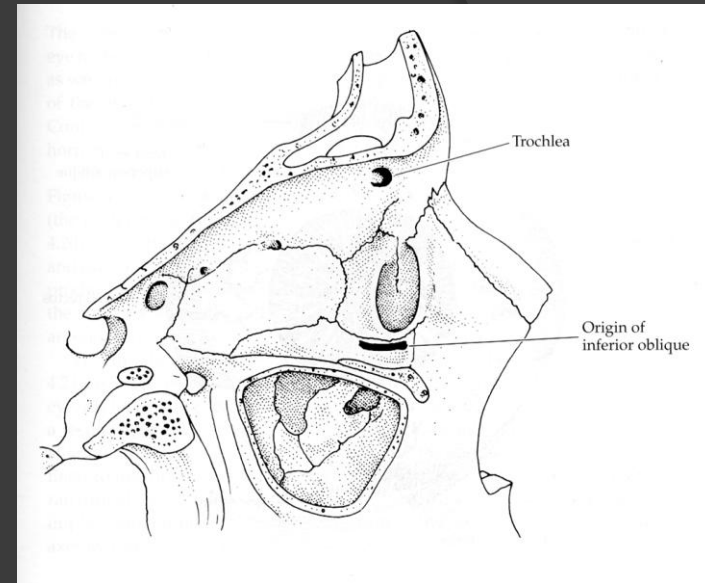

OCULAR MOTILITY AND MECHANISM

◎ Positions Of Gaze

- Primary position
- Secondary positions
- Tertiary positions



FICK'S AXES

- X (horizontal) axis
 - Lies horizontally when head is upright
 - Elevation / Depression
- Y (antero-posterior) axis
 - Torsional movements
 - Extorsion / Intorsion
- Z (vertical axis)
 - Adduction / Abduction

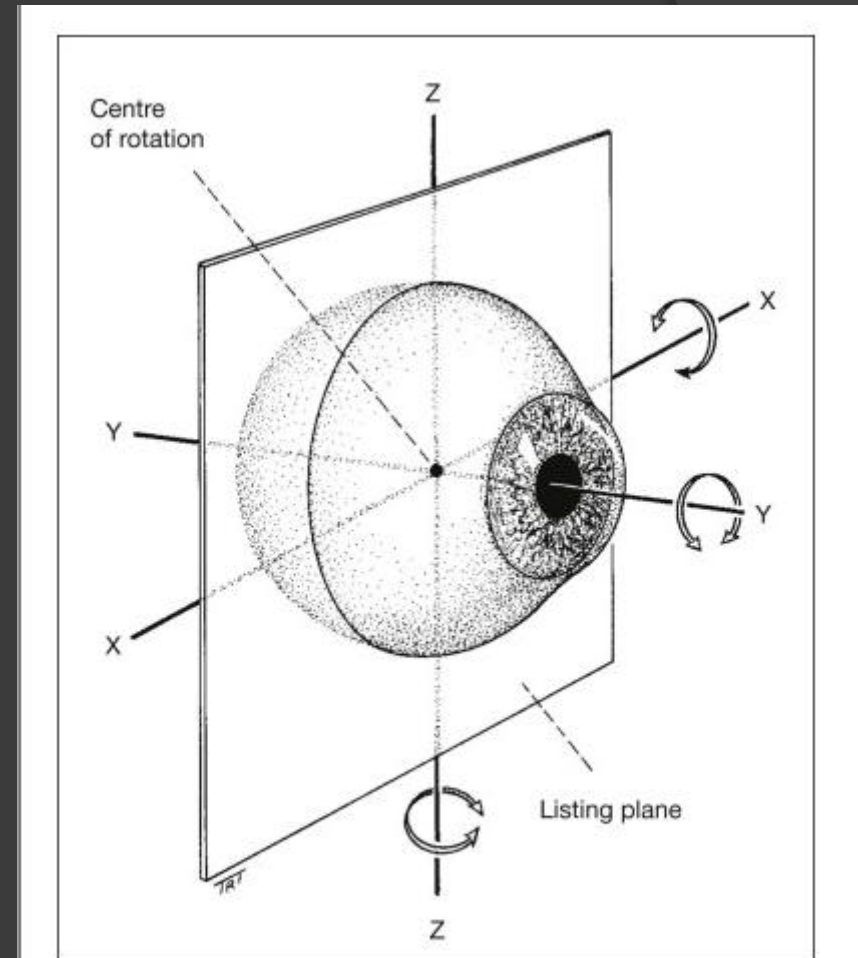

Fig. 18.3 The listing plane and axes of Fick

Factors involved in mechanics of EOM action

1. Cross sectional area of the muscle
(Muscles exert force in proportion to their cross sectional area)
2. Length of the muscle
3. Distance between the anatomic and physiologic insertion is called the arc of contact
(The power of the muscle is proportionate to its length and arc of contact)

OCULAR MOVEMENTS

MONOCULAR

1. Abduction
2. Adduction
3. Elevation
4. Depression
5. Intorsion
6. Extorsion

BINOCULAR

1. Version
2. Vergence

MUSCLES CAUSING MONOCULAR MOVEMENTS

- ⦿ Extra-ocular muscles can have primary, secondary and tertiary actions
- ⦿ Primary muscle action is the main and most powerful direction in which the eye moves when the muscle is contracted
- ⦿ Secondary muscle action is the second direction in which the eye moves when that muscle is contracted, but is not the main or most important action
- ⦿ Tertiary muscle action is the least powerful direction in which the eye moves as a result of contraction of the muscle

Actions of Recti Muscles

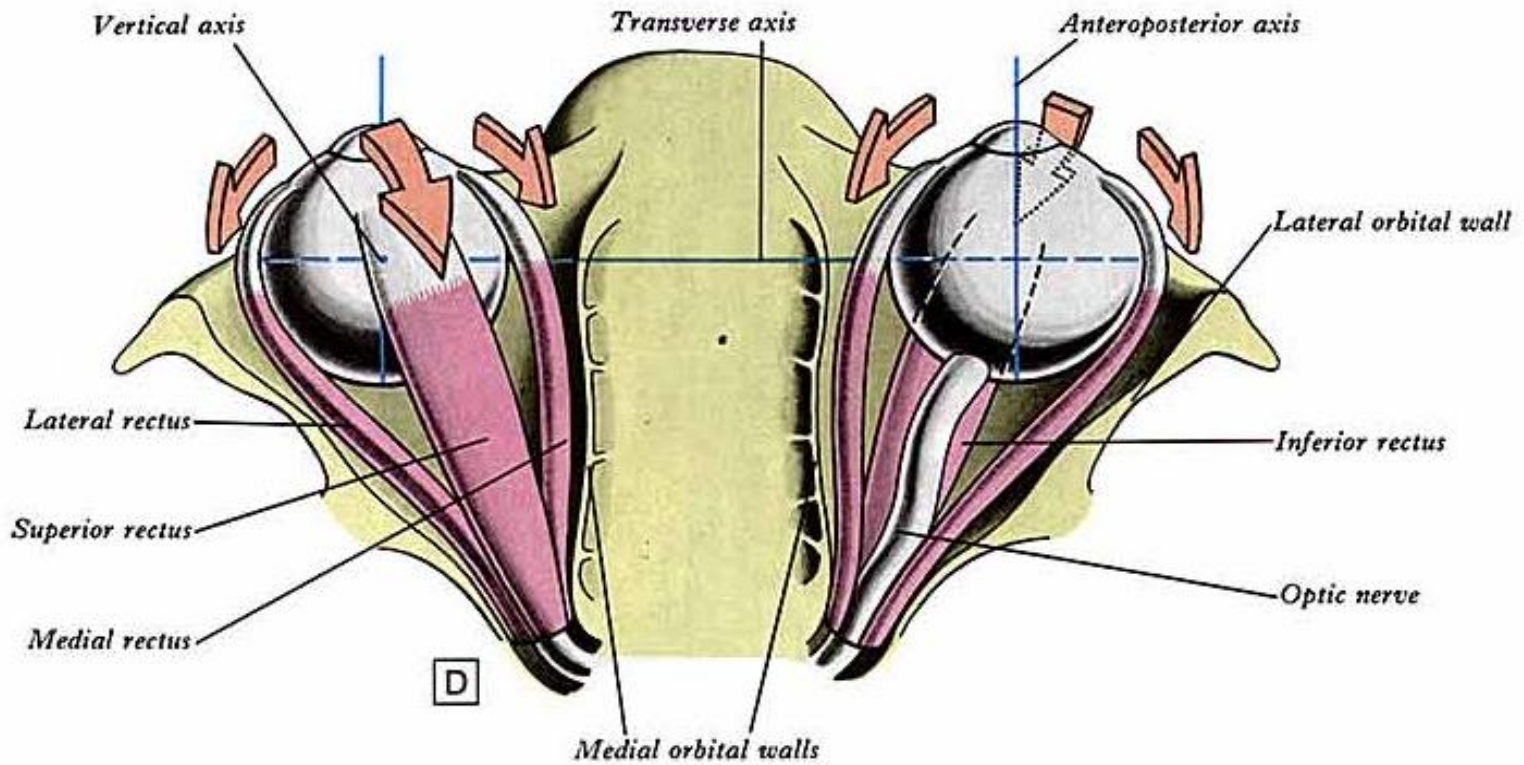

Actions of Recti Muscles

Superior rectus:

Elevation; Intorsion; Adduction

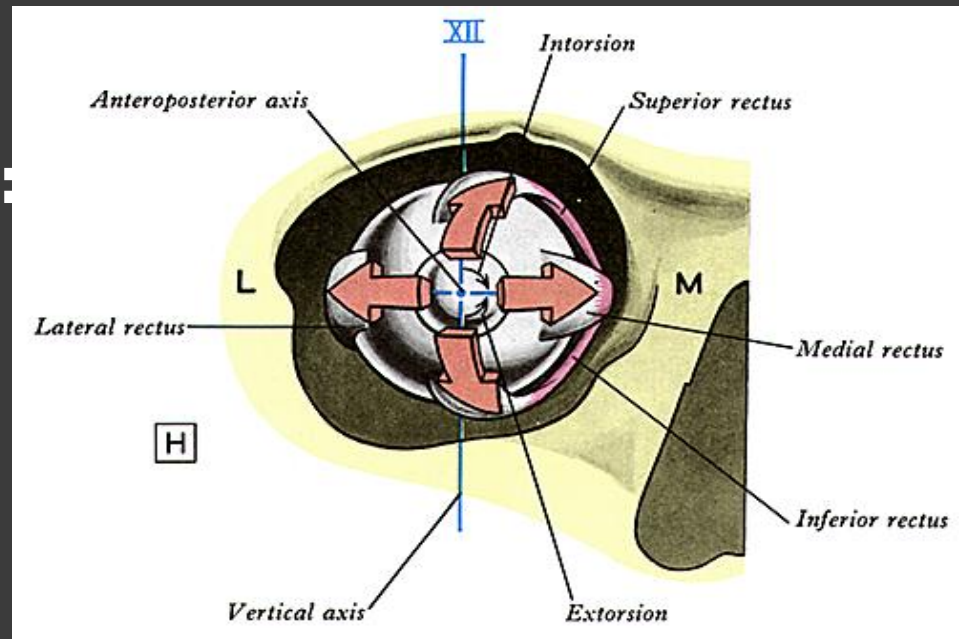

Medial rectus:
Adduction;

Inferior rectus:

Depression; Extorsion; Adduction

Lateral rectus:
Abduction

Actions of Oblique Muscles

Superior Oblique:

Intortion,
Depression,
Abduction

Inferior Oblique:

Extortion,
Elevation,
Abduction

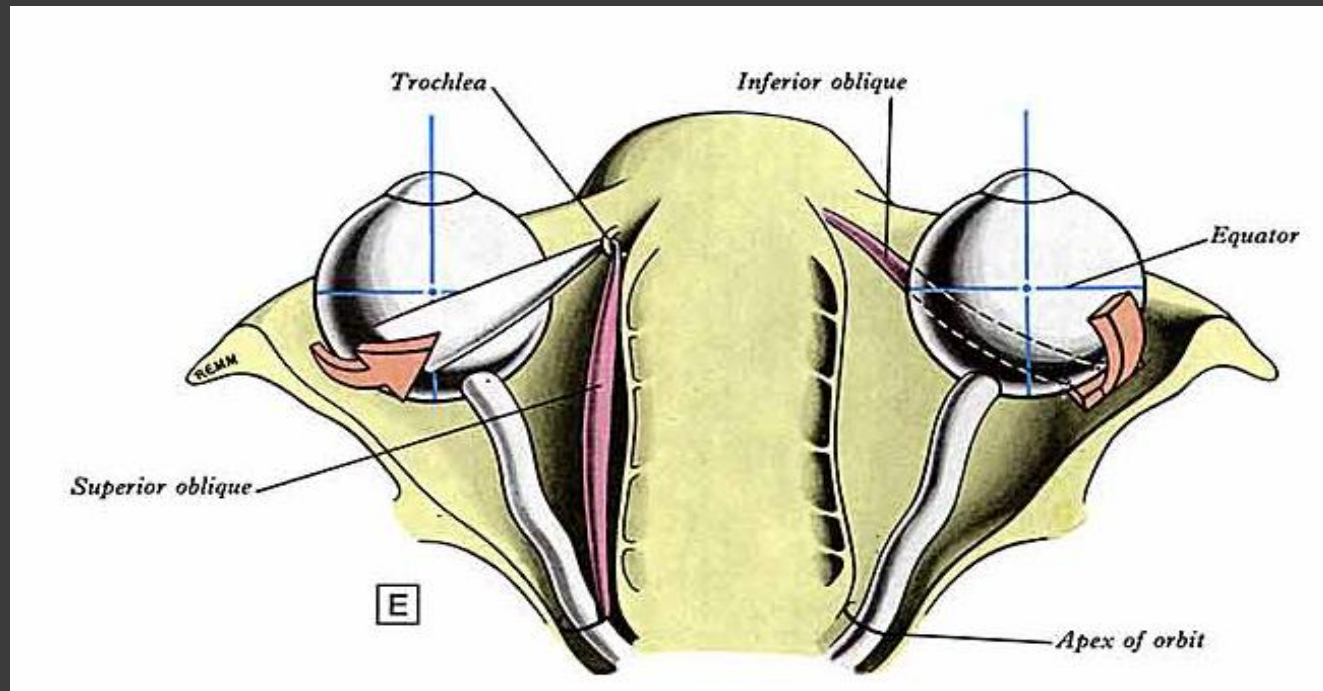

Actions of Oblique Muscles

Superior Oblique: :
Intortion
(Anterior Fibers)

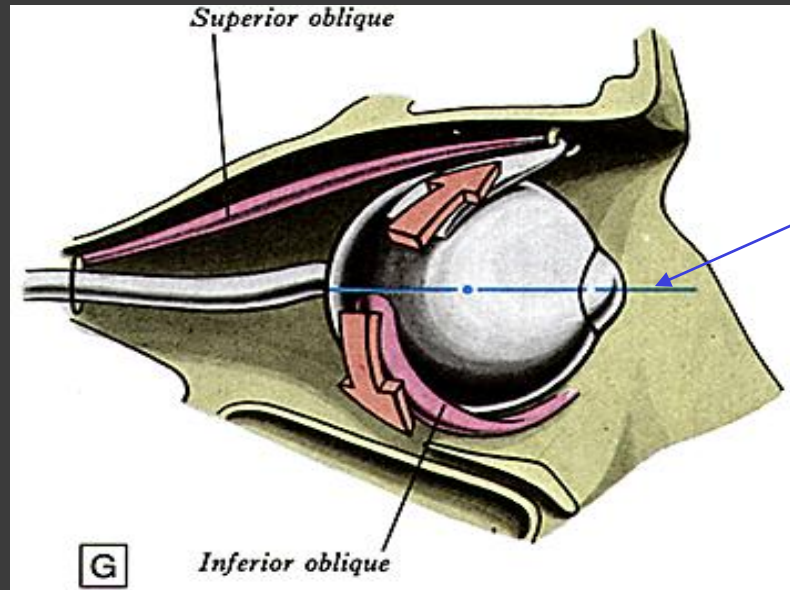

Anteroposterior axis

Inferior Oblique :
Extortion

Actions of Oblique Muscles

Vertical axis

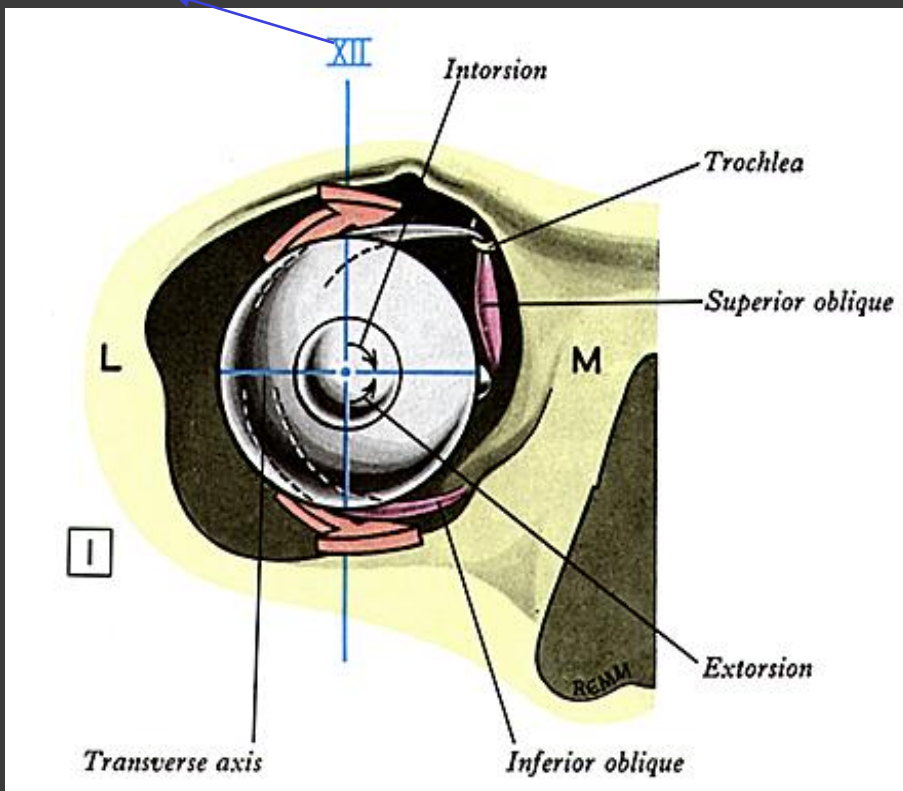

Both oblique muscles pull the posterolateral quadrant anteromedially; thus abduct the eyeball.



MUSCLE	PRIMARY ACTION	SECONDARY ACTION	TERTIARY ACTION
MR	ADDUCTION	_____	_____
LR	ABDUCTION	_____	_____
SR	ELEVATION	INTORSION	ADDUCTION
IR	DEPRESSION	EXTORSION	ADDUCTION
SO	INTORSION	DEPRESSION	ABDUCTION
IO	EXTORSION	ELEVATION	ABDUCTION

SIN

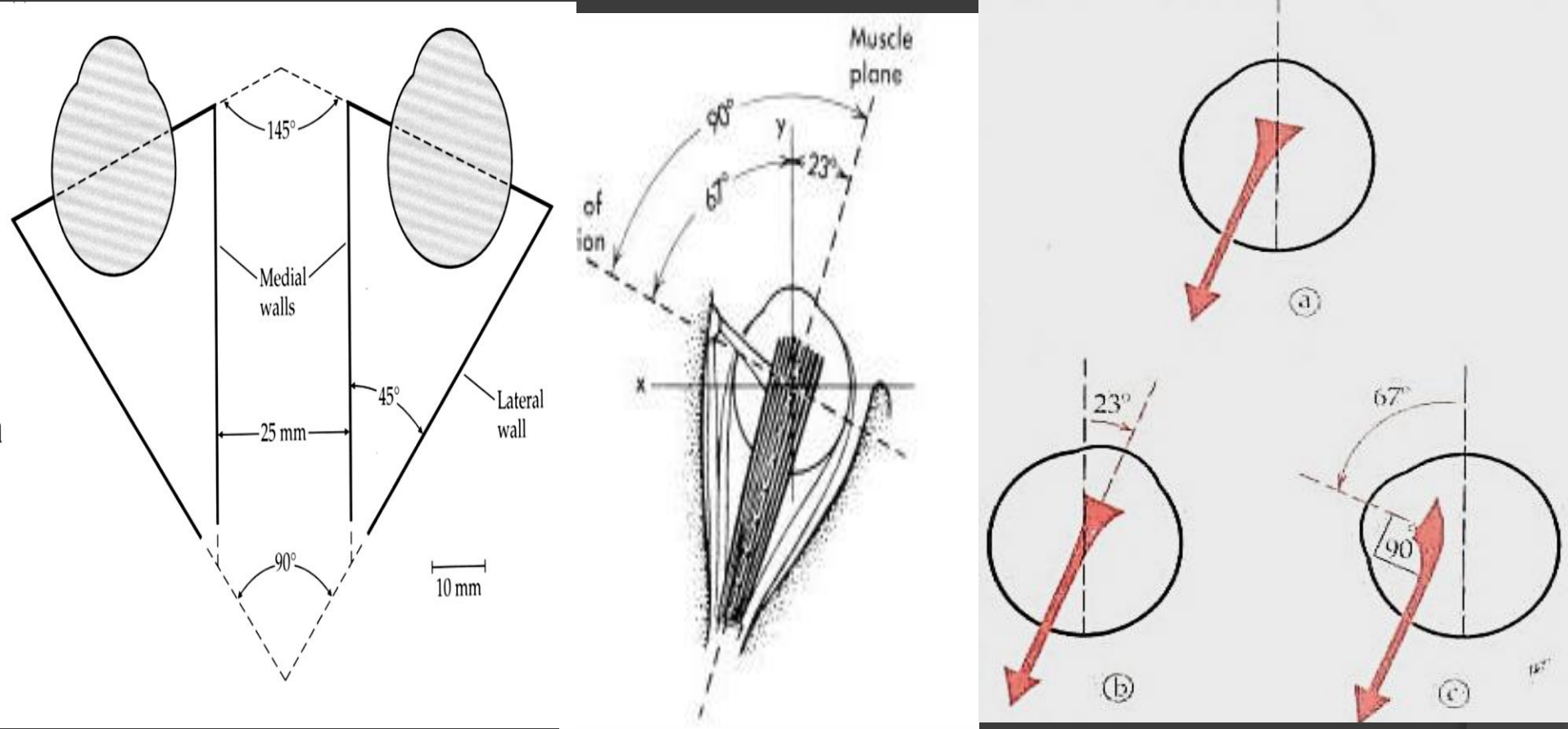

- When the globe is abducted to 23° , the visual and orbital axis coincide. In this position superior rectus acts as a pure elevator.
- If the globe were adducted to 67° the angle between the visual and orbital axis would be 90° . In this position SR would act as a pure intorter.

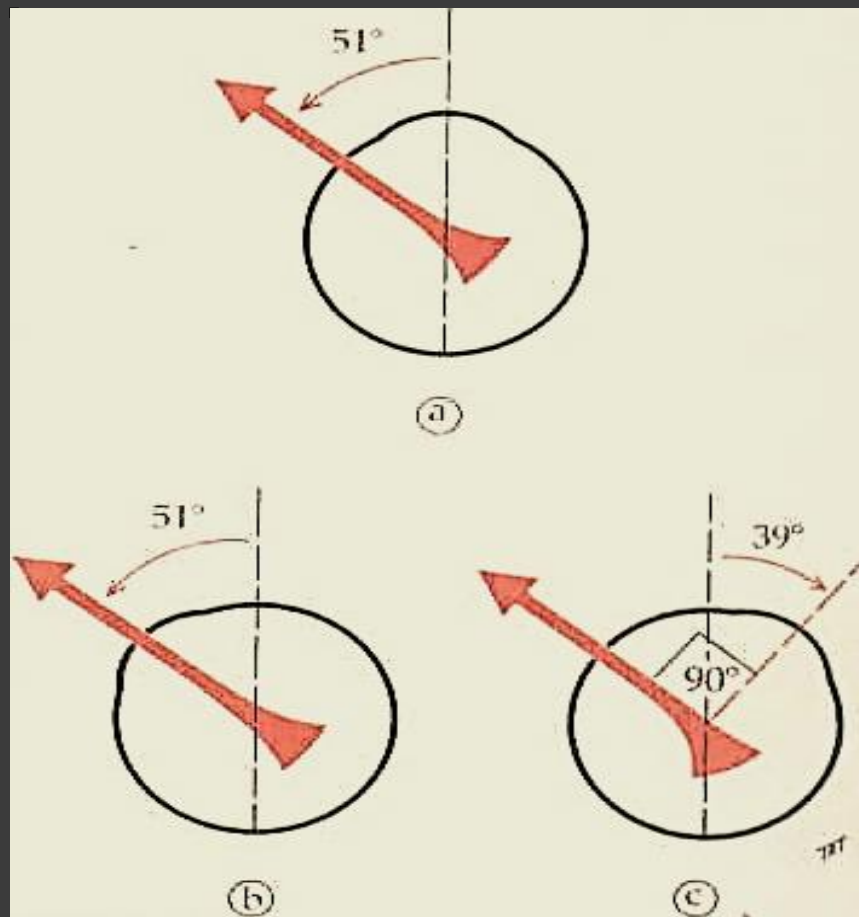

- When the globe is adducted to 51° , the visual axis coincides with the line of pull of the muscle, the SO acts as a depressor
- When the globe is abducted to 39° , the visual axis and the SO make an angle of 90° , the SO causes only intorsion

CARDINAL POSITIONS OF GAZE

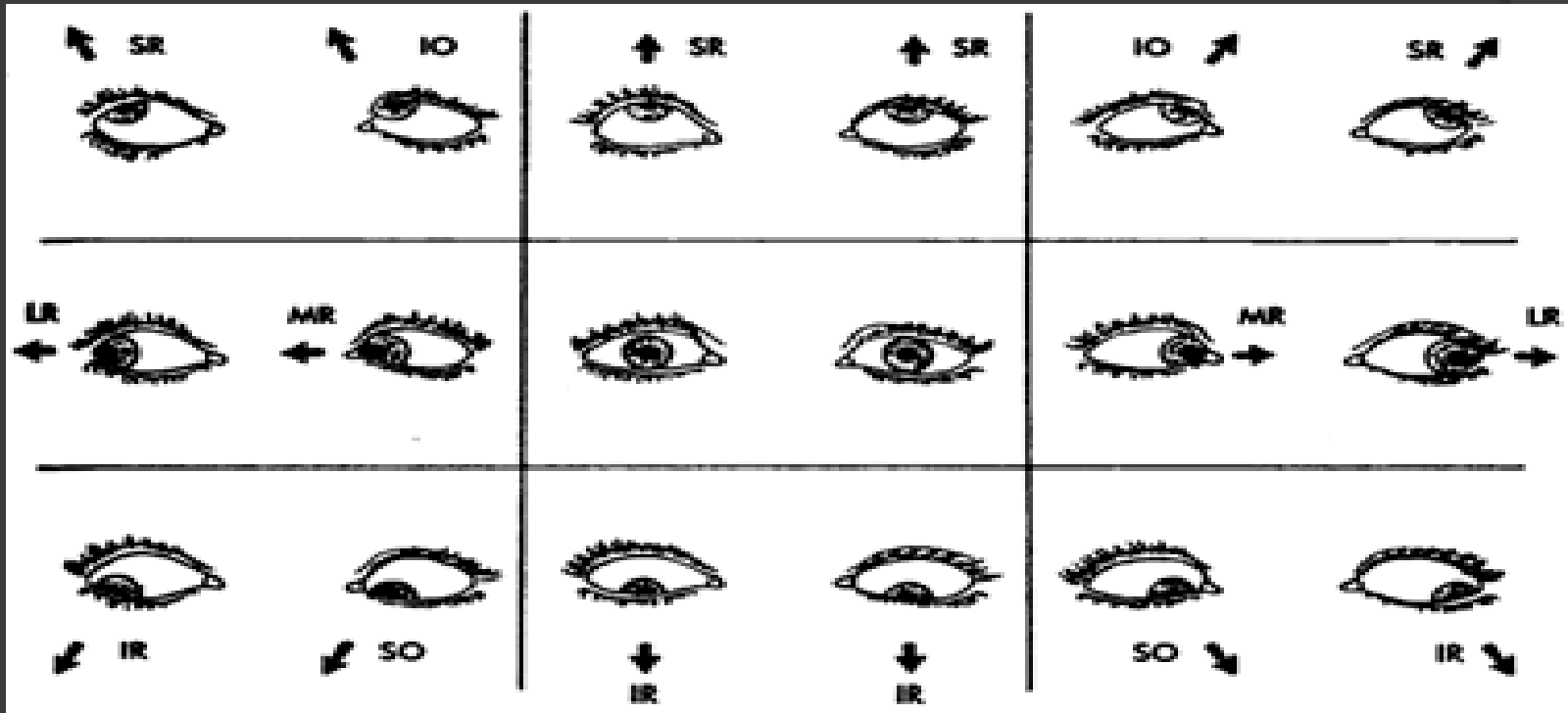

- Allows examination of each of the extraocular muscles in their main field of actions
- Six cardinal positions of gaze i.e. dextroversion, levoersion, dextrolevation, levoelevation, dextrodepression and levodepression

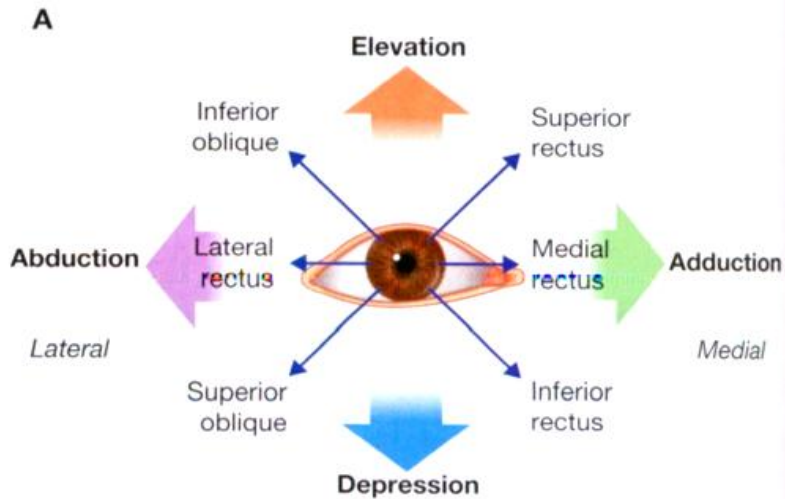

B

Muscle tested		Movement
Inferior Oblique		Look laterally and upward
Superior Oblique		Look laterally and downward
Lateral rectus		Look laterally
Medial rectus		Look medially
Superior rectus		Look medially and upward
Inferior rectus		Look medially and downward

Fig. 8.91 Actions of muscles of the eyeball. **A.** Action of individual muscles (Anatomical action). **B.** Movement of eye when testing specific muscle. (Clinical testing).

Laws of ocular motility

- ⊙ Agonist
 - Any particular EOM producing specific ocular movement
 - Ex. Right LR for right eye abduction
- ⊙ Synergists
 - Muscles of the same eye that move the eye in the same direction
 - Ex. Right SR and right IO for right eye elevation

⦿ Antagonists

- A pair of muscles in the same eye that move the eye in opposite directions
- Ex. right LR and right MR.

⦿ Yoke muscles (contralateral synergists)

- Pair of muscles, one in each eye , that produce conjugate ocular movements
- Ex. right LR and left MR in dextroversion

Listing's Law

Listing's plane

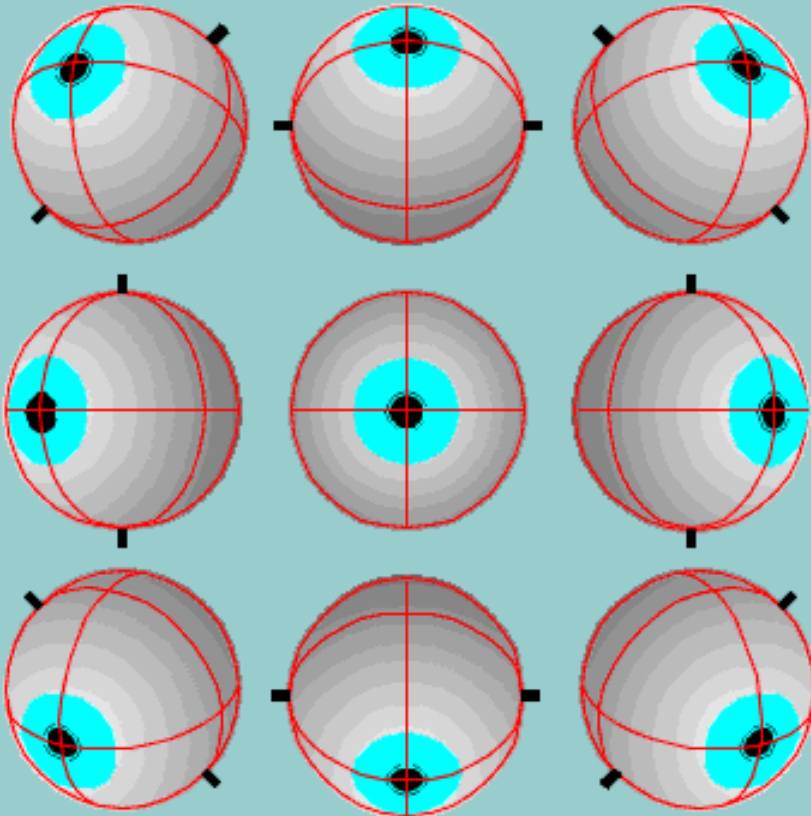

Tweed, Cadera & Vilis 1990

- ⊙ All achieved eye orientations can be reached by starting from one specific "primary" reference orientation and then rotating about an axis that lies within the plane orthogonal to the primary orientation's gaze direction (line of sight / visual axis).
- ⊙ This plane is called Listing's plane.
- ⊙ According to Listing cycloverision is 0

HERING'S LAW OF EQUAL INNERVATION

- ⦿ An equal and simultaneous innervation flows from the brain to a pair of **yoke muscles** which contracts simultaneously in different binocular movements
- ⦿ Ex. Right LR and Left MR during dextroversion
- ⦿ Applies to all normal eye movements

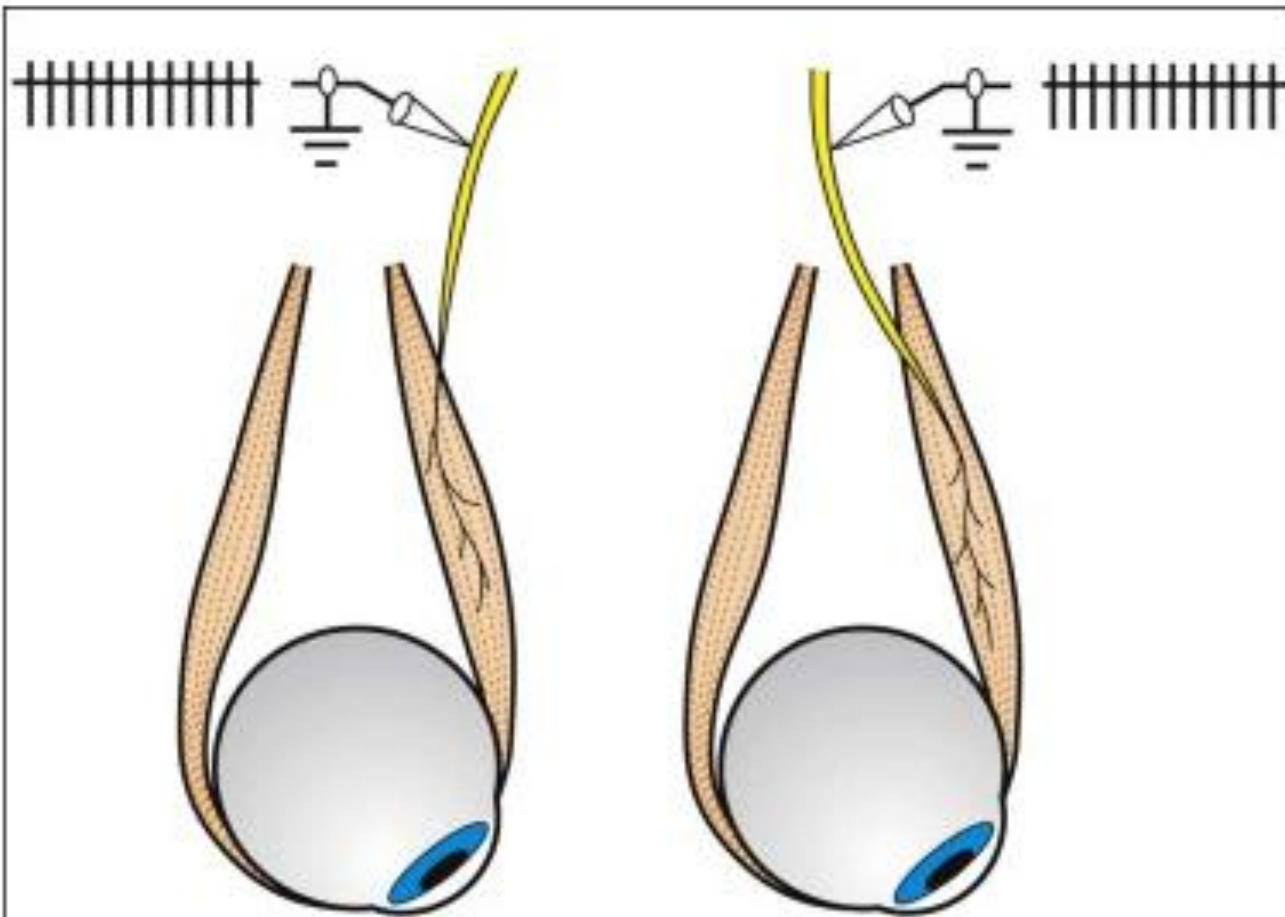

Equal innervation is supplied to yoke muscles to move both eyes into the same direction of gaze

Fig. 18.11 Hering law of equal innervation of yoke muscles

Clinical Applications

- ① Secondary Deviation in patient with paralytic squint is more than the primary deviation
- ① Excess innervation is required to the paralysed muscle to fixate
- ① Concomitant excess supply leads to more secondary deviation

SHERRINGTON'S LAW OF RECIPROCAL INNERVATION

- States that increased innervation to a contracting agonist muscle is accompanied by reciprocal inhibition of its antagonist
- Ex. During detroversion there is increased innervation to right LR and left MR accompanied by decreased flow to right MR and left LR

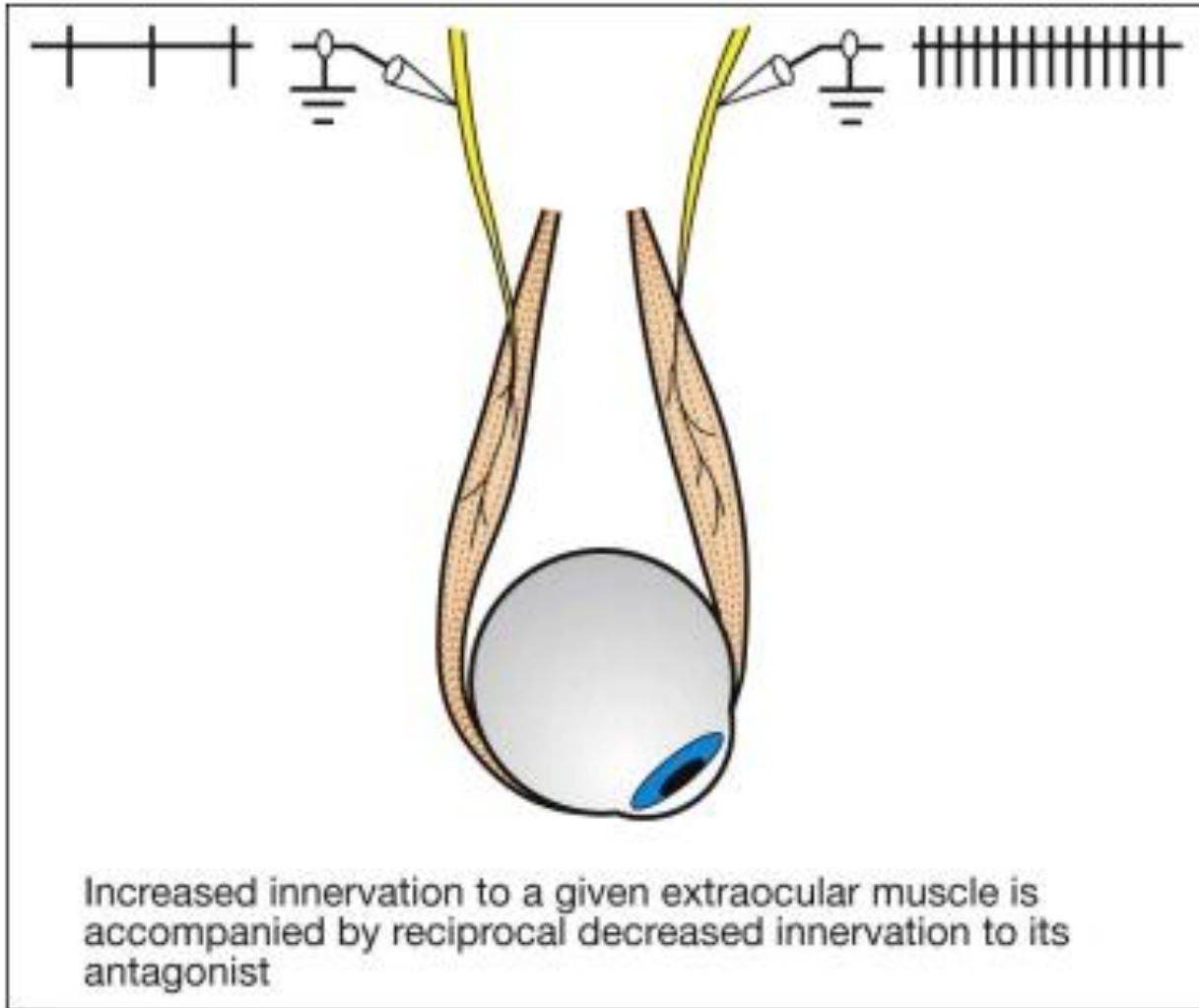

Fig. 18.10 Sherrington law of reciprocal innervation

- Occurrence of strabismus following paralysis of EOM is explained by the law
- Reciprocal innervation must be kept in mind while performing surgery of extraocular muscles
- Exceptions
 - Duane's retraction syndrome

Thank you!