

HANOI UNIVERSITY OF SCIENCE AND  
TECHNOLOGY

Center for Training of Excellent Students  
Advanced Training Program

ADVANCED LITHOGRAPHY:  
ION-BEAM  
LITHOGRAPHY

group: Hoàng Văn Tiến  
Nguyễn Đình Trung  
Phạm Đức Thịnh  
Class : MSE-K54

## ❑ Chip Fabrication Processes

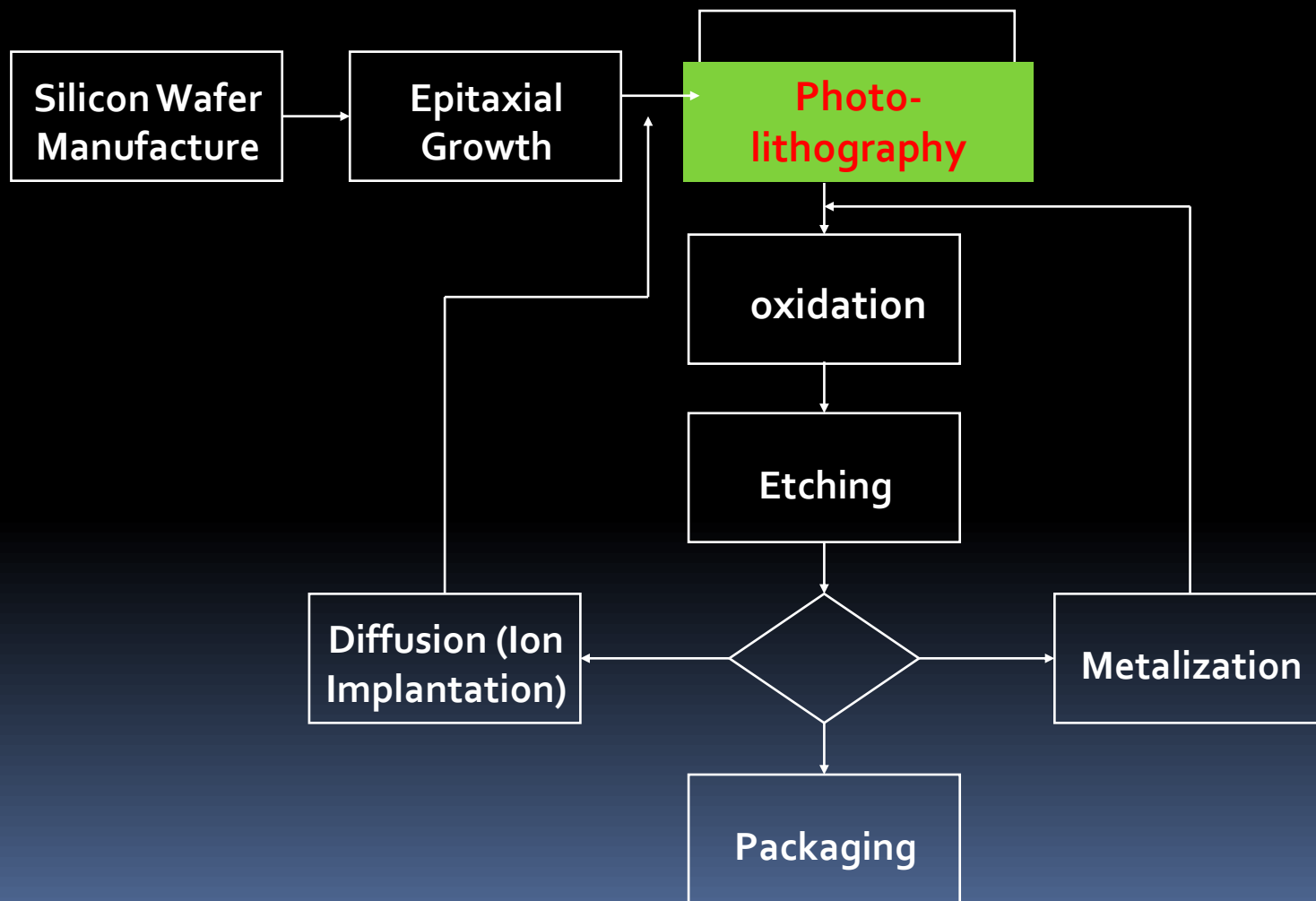

# Ion beam lithography

- **Ion beam lithography** is the practice of scanning a focused beam of ions in a patterned fashion across a surface in order to create very small structures such as integrated circuits or other nanostructures.
- Ion beam (focus ion beam) lithography has high potential to play an important role in nanometer technology because of the lack of backscattered electrons.

# Why use Ion beam lithography?

- Ions have heavy mass than electrons
- less proximity effects(due to back scattering)
- less scattering effect
- offers higher resolution patterning than UV, X-ray, or electron beam lithography because these heavier particles have more momentum.
- This gives the ion beam a smaller wavelength than even an e-beam and therefore almost no diffraction.
- The momentum also reduces scattering in the target and in any residual gas. There is also a reduced potential radiation effect to sensitive underlying structures compared to x-ray and e-beam lithography.

- Ion beam sources:

- Gas source : Hydrogen, helium,...

- Metal sources :

- The most common used source metal is Ga

- Au/Si and Au/Si/Be alloys have also been used for lithography because these sources can supply lighter mass ions

- Several implementations:

- Focused IBL (direct writing)

- Masked IBL (beam passes through ion-transparent membrane, patterned with absorber material, positioned close to coated substrate)

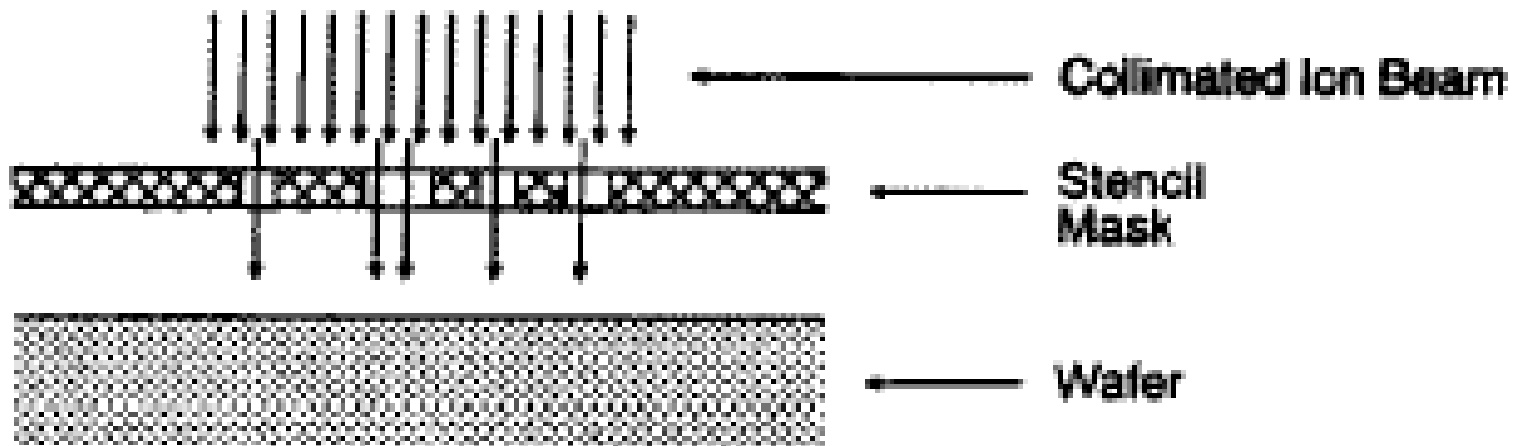

- 
- -Resists: Polymethylmethacrylate (PMMA) is most common, Poly(butene-1-sulfone), Poly(2,2,2-trifluoroethyl- $\alpha$ -chloroacrylate)
  - Features :
    - Penetration of the particle beam is small, compared to electron beam
    - Reduce blurring resulting from beam scattering (reduce proximity effect; increase localization, precision)

# Focus ion beam lithography

- Simple columns:
  - Ion source
  - Single electrostatic lens
  - Electrostatic detectors
- Two types :
  - **Low acceleration voltage (< 50 kV) columns without mass separation** (designed for applications such as mask repair, microcircuit modification, and scanning ion microscopes using a Ga LMIS)
  - **High acceleration voltage (> 100 kV) columns with mass separators.**(designed for applications such as ion implantation and lithography with an alloy LMIS)

# Low voltage column without mass separator

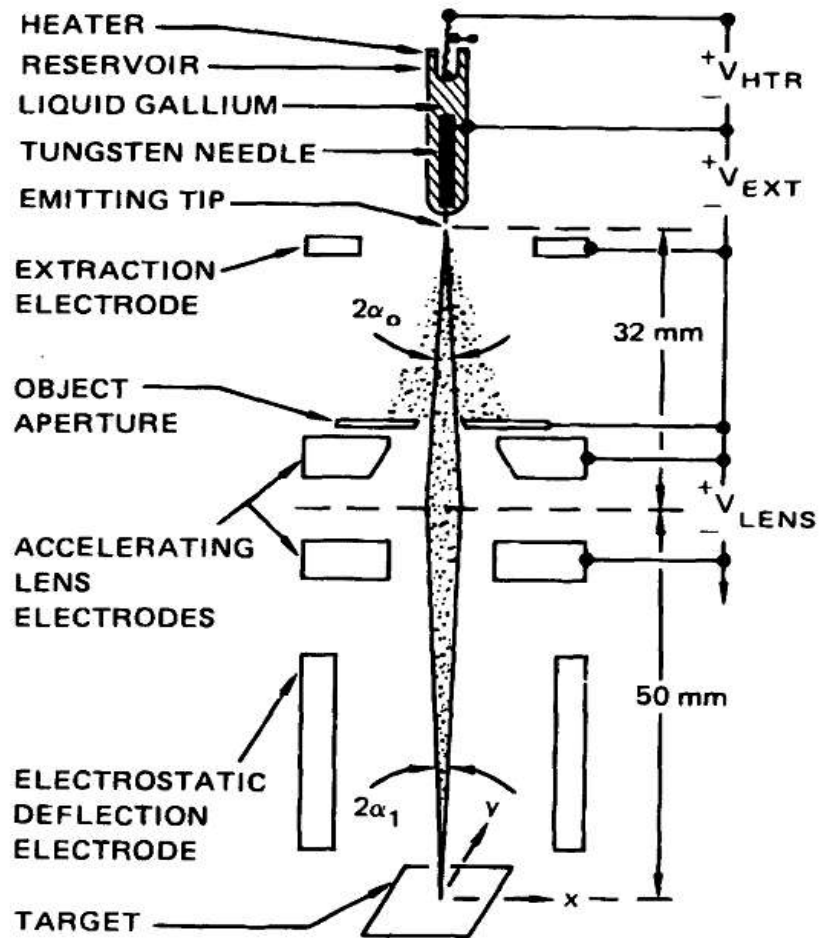

Schematic of the low voltage focusing column without mass separator [13].



## High acceleration voltage (< 50 kV) columns without mass separation

- Ions from the LMIS are focused to a crossover at an intermediate aperture by the condenser lens.
- Crossed electric and magnetic ( $E \times B$ ) fields act as a velocity filter, effectively separating the ion species by mass.
- The  $E \times B$  filter is then adjusted to allow only the desired ion species to pass through the intermediate aperture and the rest of optical column
- The objective lens then focuses the mass-selected beam onto the target.

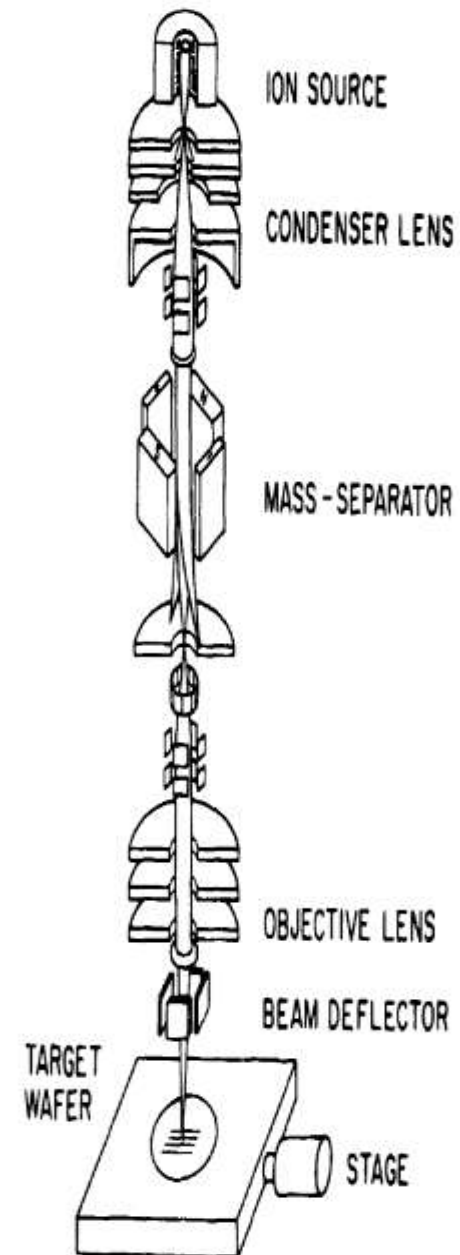

1.8: Schematic of the high voltage focusing column with mass separator [27].

# Ion sources

- **Electron bombardment ion source:** Electron beam is directed onto a gas. Produce low- energy beams of noble gas ions ( $\text{Ar}^+$ ,  $\text{He}^+$ ...)
- **Gas discharge ion source:** ions are created by plasma or by electric discharge . Used in high energy accelerators and ion implanters for semiconductor manufacture.
- **Field ionization source :** operate by desorption of ions from a sharp tip in a strong electric field .
- **Liquid metal ion source :** operate by desorption of metal ions from liquid metal under a strong electrical field

# Ion metal sources

- Emitter :
  - Small end radius
  - Coated with metal having a high surface tension and low vapor pressure at its melting point
  - The emitter is heated to the melting point of the metal while a high positive voltage is placed on it relative to an extraction electrode.
  - The liquid metal is drawn into a conical shape by the balance between the electrostatic and surface tension forces.
  - The apex of the liquid cone is drawn to an end radius so small that the high electric field causes ions to begin to form through field evaporation.
  - The cone apex is believed to have a radius of about 5 nm
  - The most common source metal is Ga.
  - Au/Si and Au/Si/Be alloys have also been used for lithography because these sources can supply lighter mass ions.

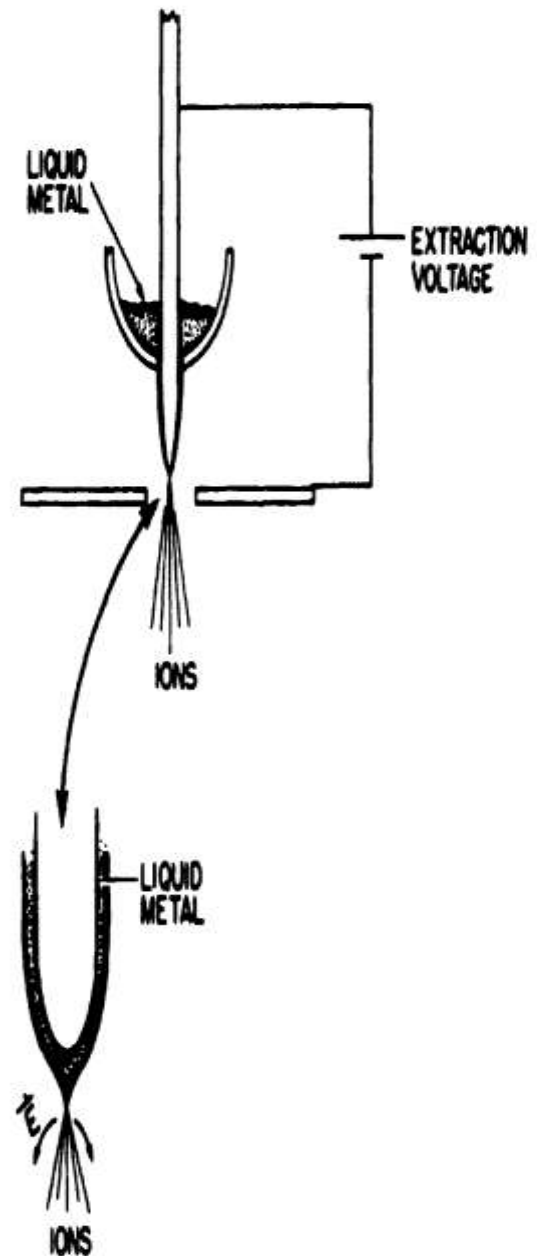

Schematic of liquid metal ion source with enlarged view of tip showing liquid pulled into a cusp by the electric field [10].

# Gas ion sources

- Ionization region: plasma formed
- Potential placed at extraction region removes ions from chamber

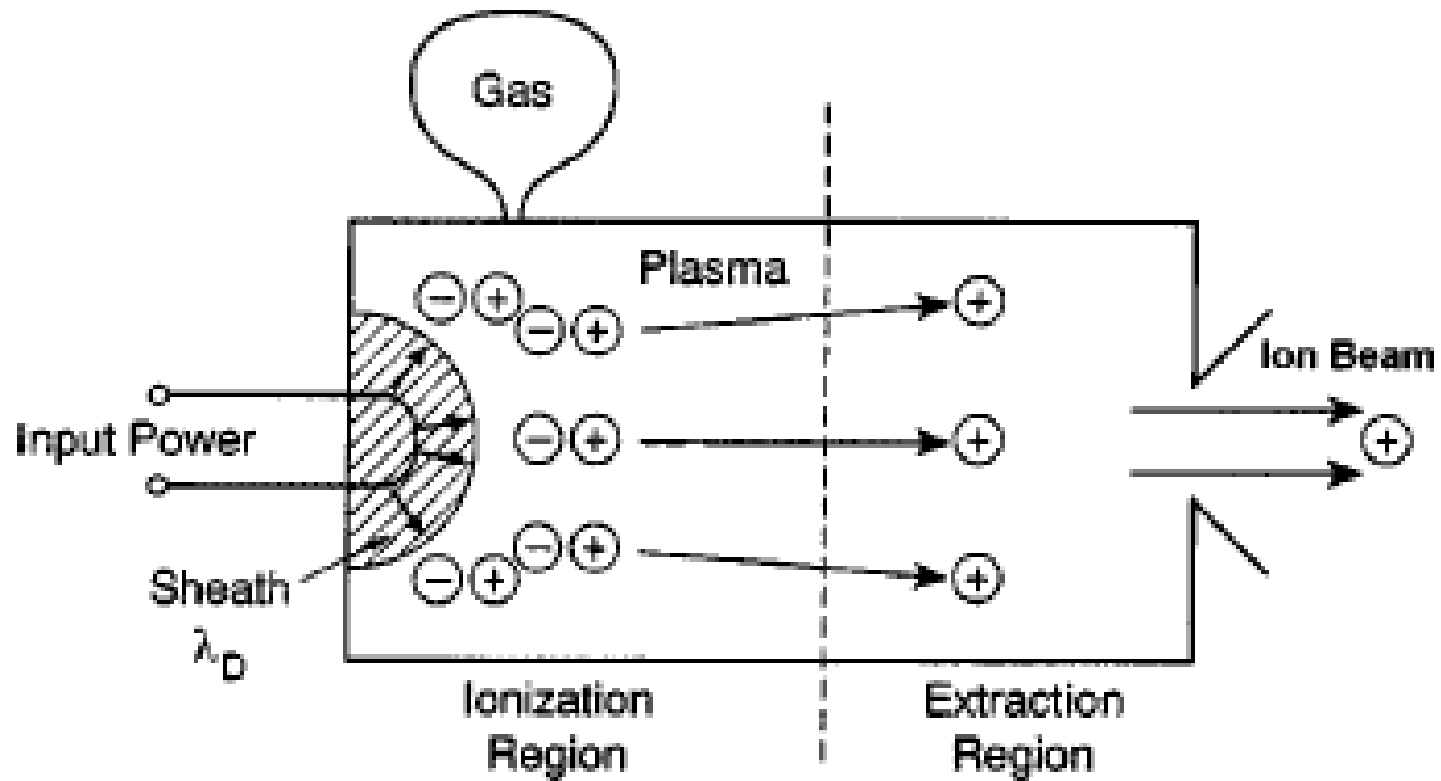

# Lithography

- Lithography is employed to defined a patterns inside a target.
- Patterns can be defined by:
  - Physically sputtering the target atoms (**FIB milling**)
  - Striggering chemical reactions inside an adsorbed layer of a precursor gas (**gas-assisted processing**)
  - Ion implantation

# FIB milling and gas-assisted processing

-When an ion hits the target, surface elastic and inelastic scattering processes will take place

- Inelastic processes are responsible for the generation of photons and secondary electron
- Elastic processes scattering will transfer kinetic energy from the ion to the target atoms

-The energy transfer will cause the displacement of the target atoms and trigger a recoil cascade whereby kinetic energy is transferred from one atom to another by elastic scattering processes

-Number of target atoms a single ion is able to remove is largely dependent on the target material, the ion species, its energy and the angle of incidence of ion beams

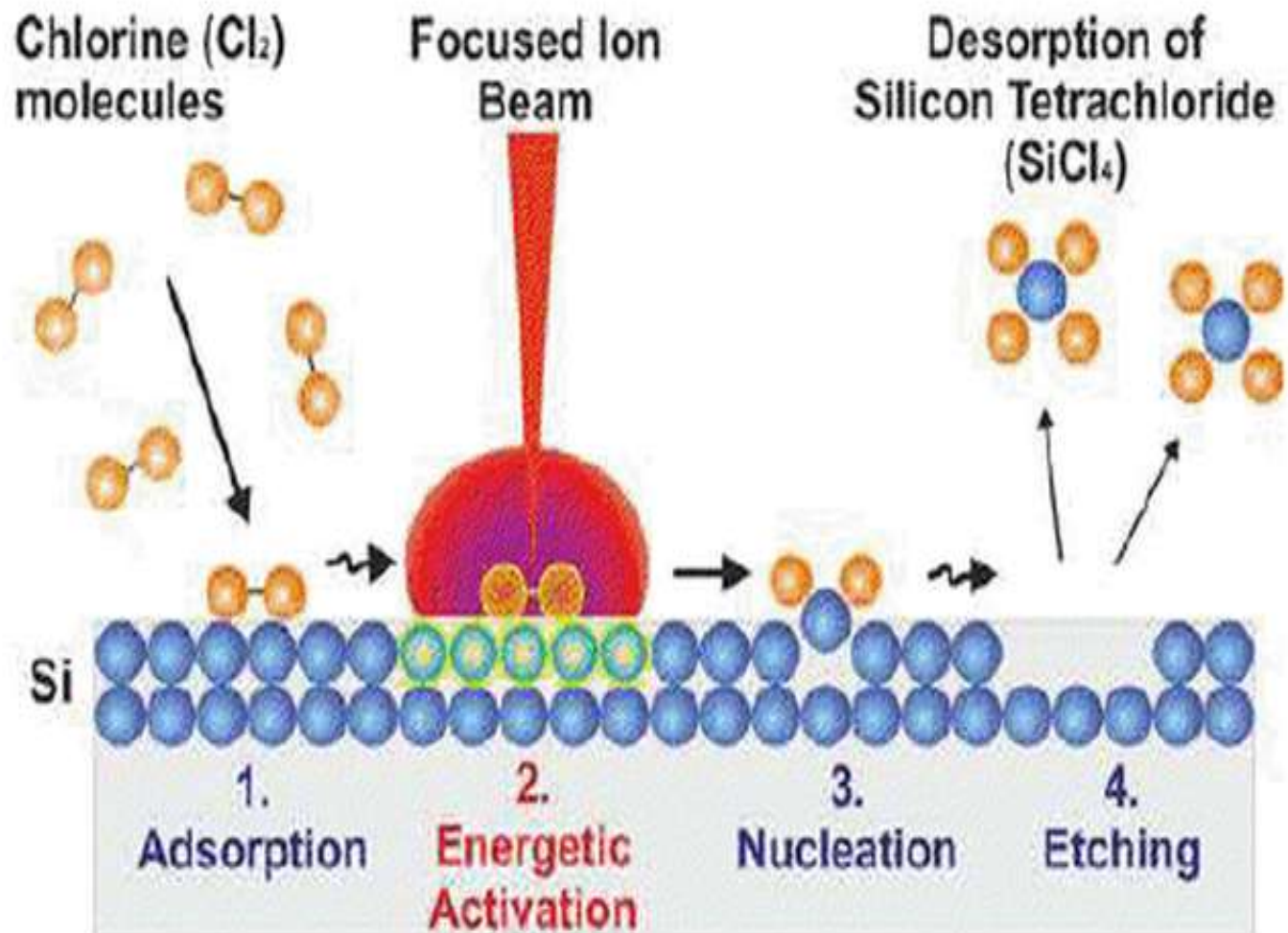

7. Schematic illustration of the FIB-induced etching process

# Ion milling

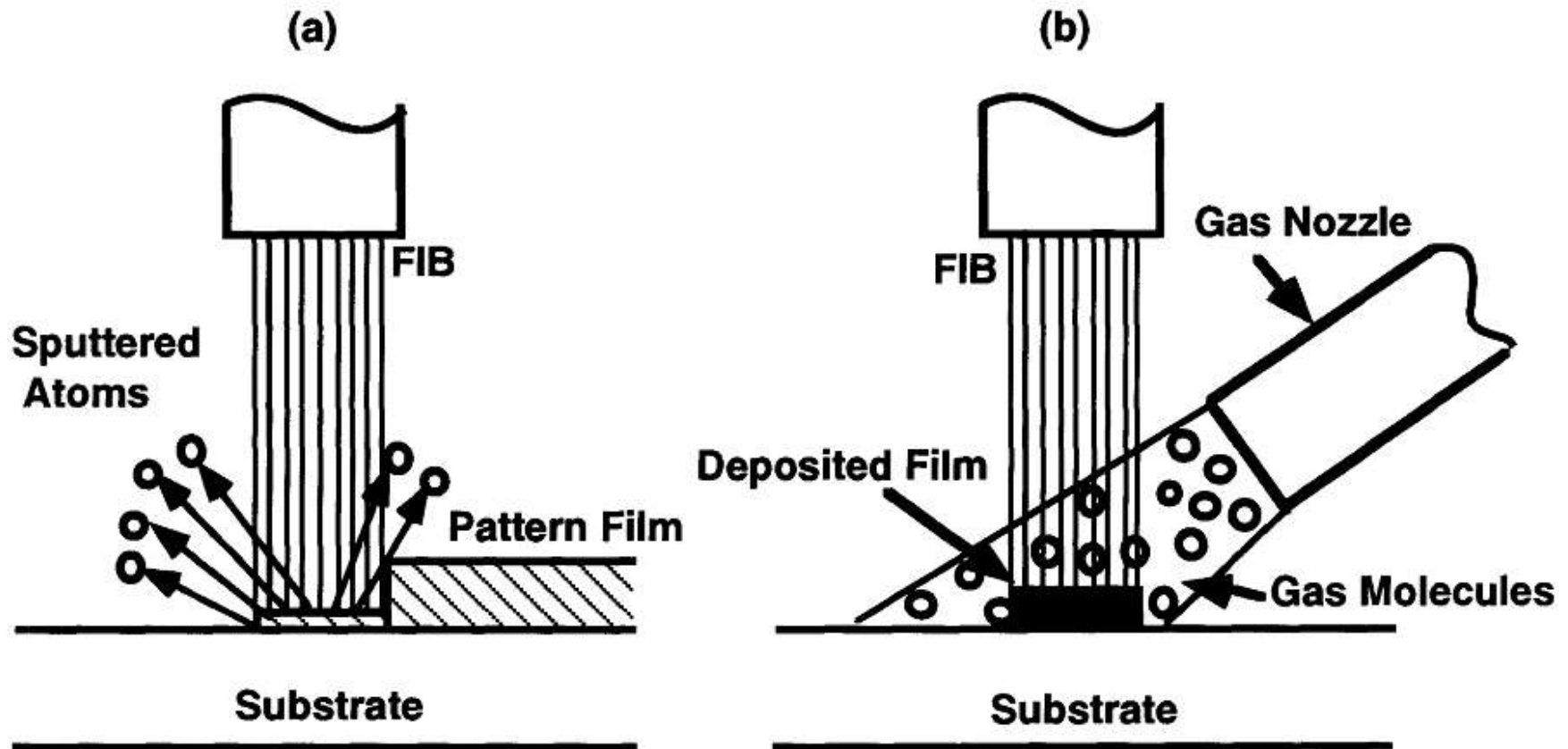
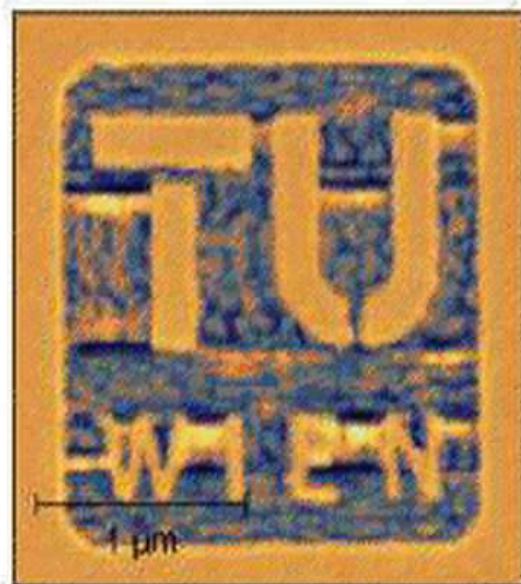
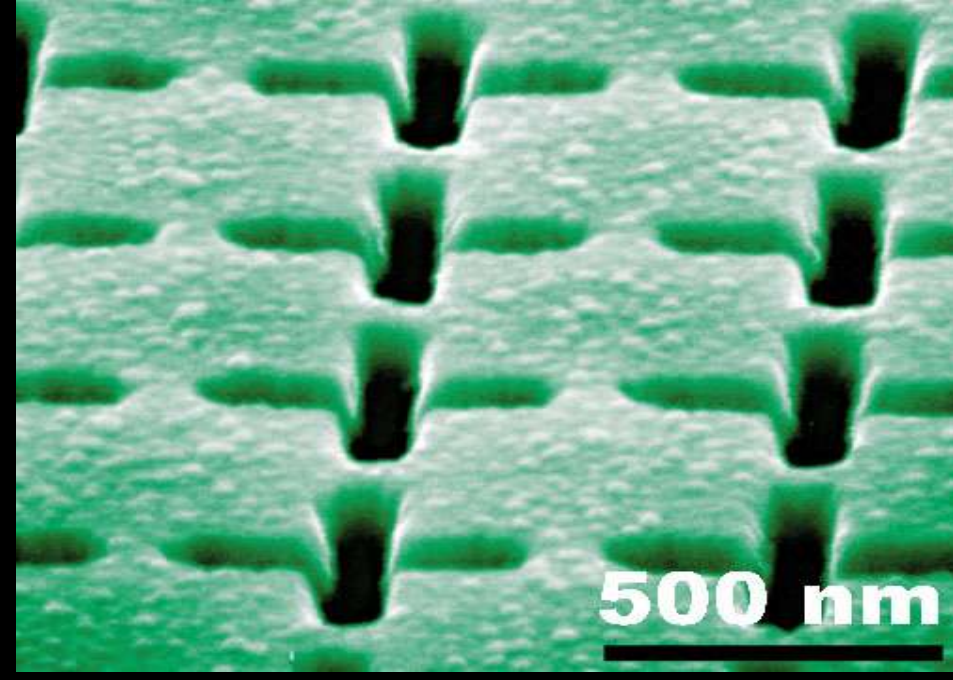
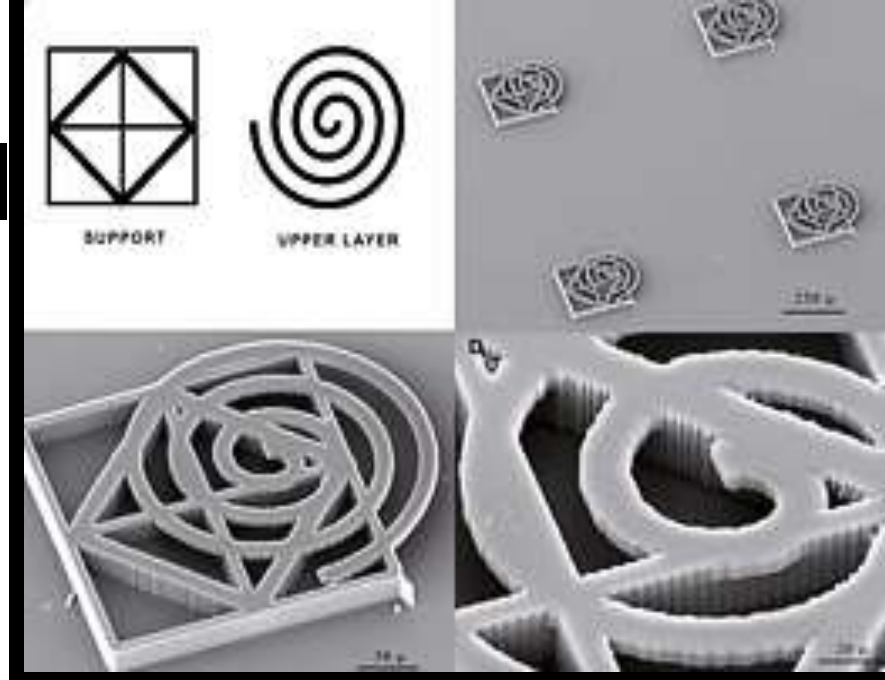

Fig. 1.10: Schematics of (a) FIB milling and (b) FIB induced deposition.





a) Ruthenium



b) Aluminium doped zinc oxide (AZO)



# Advantages and disadvantages

- Advantages:
  - High exposure sensitivity: 2 or more orders of magnitude higher than that of electron beam lithography
  - Negligible ion scattering in the resist
  - Low back scattering from the substrate
  - Can be used as physical sputtering etch and chemical assisted etch.
  - Can also be used as direct deposition or chemical assisted deposition, or doping .
- Disadvantages:
  - Lower throughput, extensive substrate damage



# Conclusions

- Ion beam lithography is a versatile technique with several variations of the process .
- Ion beam lithography has been found to be useful for transferring high-fidelity patterns on three-dimensional surfaces
- This process can anyway be an advantage in the applications where larger surface areas are needed.

# References

- L. F. Thompson, C. G. Willson, and M. J. Boeden, Introduction Microlithography (American Chemical Society, Washington, D. C., 1983)
- [www.wikipedia.org](http://www.wikipedia.org)
- <http://www.intechopen.com/books/recent-advances-in-nanofabrication-techniques-and-applications/focused-ion-beam-lithography>
- [www.physics.ucdavis.edu/.../Lithography2.pd](http://www.physics.ucdavis.edu/.../Lithography2.pd)
- [www.seminarprojects.net/.../ion-beam-lithography](http://www.seminarprojects.net/.../ion-beam-lithography)



**Thank for your  
listening**