

## **Chapter Four**

### **Layout planning**

#### **4-1-Introduction**

Layout planning *is deciding on the best physical arrangement of all resources that consume space within a facility*. These resources might include a desk, a work center, a cabinet, a person, an entire office, or even a department. Decisions about the arrangement of resources in a business are not made only when a new facility is being designed; they are made any time there is a change in the arrangement of resources, such as a new worker being added, a machine being moved, or a change in procedure being implemented. Also, layout planning is performed any time there is an expansion in the facility or a space reduction.

The arrangement of resources in a facility can significantly affect the *productivity* of a business. A lot of wasted time, energy, and confusion can result from a *poor layout*. There are also other reasons layout planning is important. In many work environments, such as office settings, face-to-face interaction between workers is important. Proper layout planning can be critical in building good working relationships, increasing the flow of information, and improving communication. Similarly, in retail organizations layout can affect sales by promoting visibility of key items and contributing to customer satisfaction and convenience. Layout planning affects many areas of a business, and its importance should not be underestimated.

#### **Layout Planning**

The term '**layout planning**' can be applied at various levels of planning:

**Plant location planning** (where you are concerned with location of a factory or a warehouse or other facility.) This is of some importance in design of multi-nationally cooperating, Global-supply Chain systems.

**Department location Planning:** This deals with the location of different departments or sections within a plant/factory. This is the problem we shall study in a little more detail, below.

**Machine location problems:** which deal with the location of separate machine tools, desks, offices, and other facilities within each cell or department.

**Detailed planning:** The final stage of a facility planning is the generation, using CAD tools or detailed engineering drawings, of scaled models of the entire floor plans, including details such as the location of power supplies, cabling for computer networks and phone lines, etc.

**The Department Location Problem:** A department is defined as any single, large resource, with a well defined set of operations, and fixed material entry and exit points. Examples range from a large machine tool, or a design department. The aim is to develop a BLOCK PLAN showing the relative locations of the departments.

## 4-2- Principles of Plant Layout

**The primary criteria** for evaluating any layout will be the: minimization of material handling costs.

MH cost components: depreciation of MH equipment, variable operating costs, and labor expenses. Also, MH costs are typically directly proportional to (a) the frequency of movement of material, and (b) The length over which material is moved.

1. Principle of integration: A good layout is one that integrates men, materials, machines and supporting services and others in order to get the optimum utilisation of resources and maximum effectiveness.
2. Principle of minimum distance: This principle is concerned with the minimum travel (or movement) of man and materials. The facilities

should be arranged such that, the total distance travelled by the men and materials should be minimum and as far as possible straight line movement should be preferred.

3. Principle of cubic space utilisation: The good layout is one that utilise both horizontal and vertical space. It is not only enough if only the floor space is utilised optimally but the third dimension, i.e., the height is also to be utilised effectively.
4. Principle of flow: A good layout is one that makes the materials to move in forward direction towards the completion stage, i.e., there should not be any backtracking.
5. Principle of maximum flexibility: The good layout is one that can be altered without much cost and time, i.e., future requirements should be taken into account while designing the present layout.
6. Principle of safety, security and satisfaction: A good layout is one that gives due consideration to workers safety and satisfaction and safeguards the plant and machinery against fire, theft, etc.
7. Principle of minimum handling: A good layout is one that reduces the material handling to the minimum.

**Advantages of the criteria (reduced material movements):**

1. Reduction of Aisle space required.
2. Lower WIP levels.
3. Lower throughput times.
4. Less product damage and lower obsolescence.
5. Reduced storage space.
6. Simplified material control and scheduling.
7. Less overcrowding in system.

### **4-3-CLASSIFICATION OF LAYOUT**

Layouts can be classified into the following five categories:

1. Process layout also called Functional layout
2. Product layout also called Assembly lines layout
3. Combination layout
4. Fixed position layout also called project type
5. Group layout or Cellular Layout

#### **4-3-1-Process Layout/ / Functional layouts**

Process layouts are layouts that group resources *based on similar processes or functions*. This type of layout is seen in companies with intermittent processing systems. Process layout is recommended for batch production. All machines performing similar type of operations are grouped at one location in the process layout e.g., all lathes, milling machines, etc. are grouped in the shop will be clustered in like groups. Thus, in process layout the arrangement of facilities are grouped together according to their functions. A typical process layout is shown in Fig.(4.1).The flow paths of material through the facilities from one functional area to another vary from product to product. Usually the paths are long and there will be possibility of backtracking.

Process layout is normally used when the production volume is not sufficient to justify a product layout. Typically, job shops employ process layouts due to the variety of products manufactured and their low production volumes. *The challenge in process layouts is to arrange resources to maximize efficiency and minimize waste of movement.* If the process layout has not been designed properly, many products will have to *be moved long distances*, often on a daily basis.

## Advantages

1. In process layout machines are better utilized and fewer machines are required.
2. Flexibility of equipment and personnel is possible in process layout.

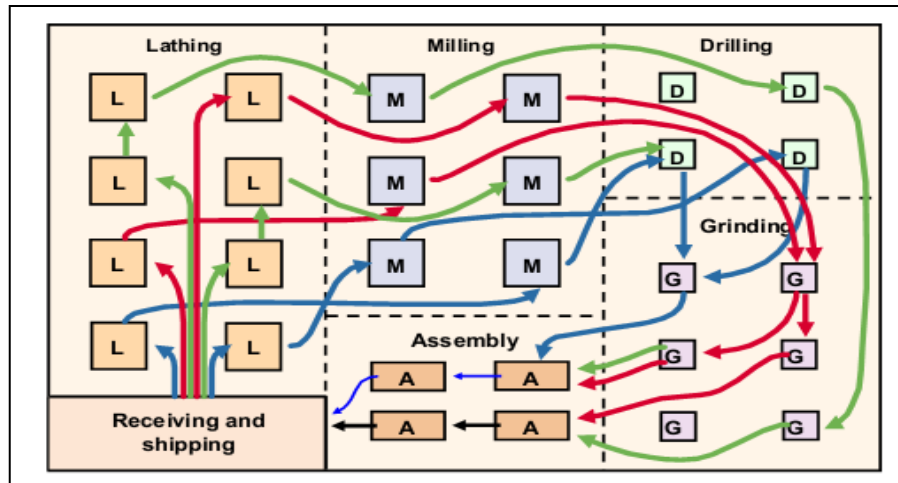

Fig. (4.1) Process layout

3. Lower investment on account of comparatively less number of machines and lower cost of general purpose machines.
4. Higher utilization of production facilities.
5. A high degree of flexibility with regards to work distribution to machineries and workers.
6. The diversity of tasks and variety of job makes the job challenging and interesting.
7. Supervisors will become highly knowledgeable about the functions under their department.

## Limitations

1. Backtracking and long movements may occur in the handling of materials thus, reducing material handling efficiency.

2. Material handling cannot be mechanized which adds to cost.
3. Process time is prolonged which reduce the inventory turnover and increases the in-process inventory.
4. Lowered productivity due to number of set-ups.
5. Throughput (time gap between in and out in the process) time is longer.
6. Space and capital are tied up by work-in-process.

### 4-3-2 - Product Layout / (assembly lines layout)

In this type of layout, machines and auxiliary services are located according to the processing sequence of the product. If the volume of production of one or more products is large, the facilities can be arranged to achieve efficient flow of materials and lower cost per unit. Special purpose machines are used which perform the required function quickly and reliably.

The product layout is selected when the volume of production of a product is high such that a separate production line to manufacture it can be justified. In a strict product layout, machines are not shared by different products. Therefore, the production volume must be sufficient to achieve satisfactory utilization of the equipment. See Table 4-1 for the comparison between process and product layout. A typical product layout is shown in Fig. (4.2).

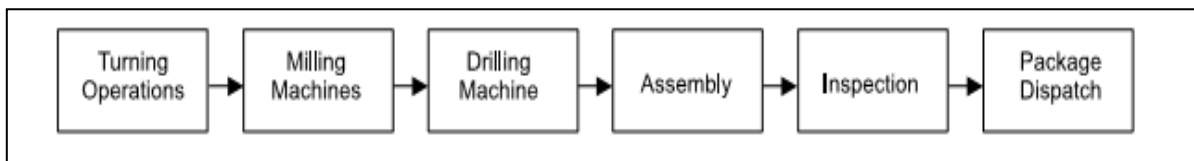

Fig. (4.2) Product layout

### Advantages

1. The flow of product will be smooth and logical in flow lines.

2. In-process inventory is less.
3. Throughput time is less.
4. Minimum material handling cost.
5. Simplified production, planning and control systems are possible.
6. Less space is occupied by work transit and for temporary storage.
7. Reduced material handling cost due to mechanized handling systems and straight flow.
8. Perfect line balancing which eliminates bottlenecks and idle capacity.
9. Manufacturing cycle is short due to uninterrupted flow of materials.
10. Small amount of work-in-process inventory.
11. Unskilled workers can learn and manage the production.

**Limitations**

1. A breakdown of one machine in a product line may cause stoppages of machines in the downstream of the line.
2. A change in product design may require major alterations in the layout.
3. The line output is decided by the bottleneck machine.
4. Comparatively high investment in equipments is required.
5. Lack of flexibility. A change in product may require the facility modification.

Table ( 4-1) Characteristics of Process and Product Layouts

Process Layouts	Product Layouts
Able to produce a large number of different products.	Able to produce a small number of products efficiently.
Resources used are general purpose.	Resources used are specialized.
Facilities are more labor intensive.	Facilities are more capital intensive.
Greater flexibility relative to the market.	Low flexibility relative to the market.
Slower processing rates.	Processing rates are faster.
High material handling costs.	Lower material handling costs.
Higher space requirements.	Lower space requirements.

### 4-3-3 - Combination Layout

A combination of process and product layouts combines the advantages of both types of layouts.

A combination layout is possible where an item is being made in different types and sizes. Here machinery is arranged in a process layout but the process grouping is then arranged in a sequence to manufacture various types and sizes of products. It is to be noted that the sequence of operations remains same with the variety of products and sizes. Figure 4.3 shows a combination type of layout for manufacturing different sized gears.

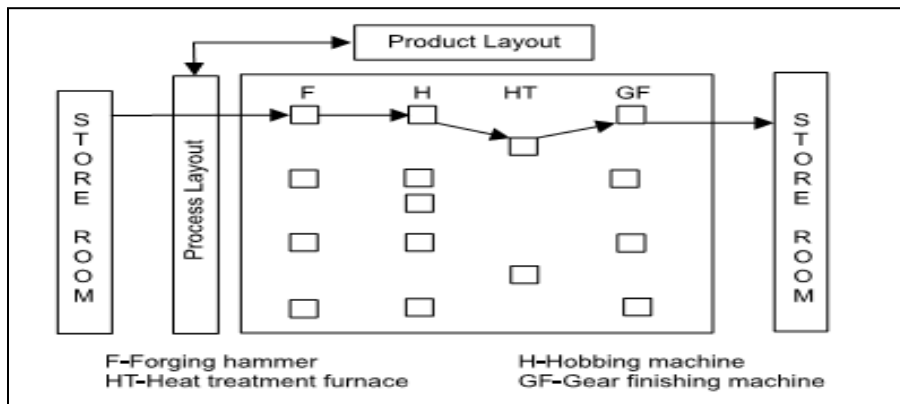

Figure ( 4.3) a combination layout

### 4-3-4 - Fixed Position Layout / project type

This is also called the project type of layout. See Fig. ( 4.4). In this type of layout, the material, or major components remain in a fixed location and tools, machinery, men and other materials are brought to this location. This type of layout is suitable when one or a few pieces of identical heavy products are to be manufactured and when the assembly consists of large number of heavy parts, the cost of transportation of these parts is very high as in ships and airplanes assembly.

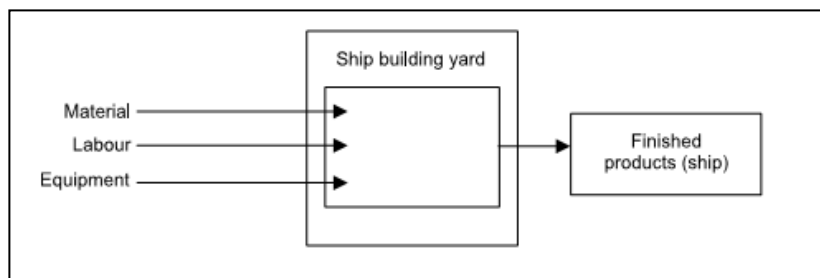

Fig. 4.4  
Fixed position layout



## **Advantages**

The major advantages of this type of layout are:

1. Helps in job enlargement and upgrades the skills of the operators.
2. The workers identify themselves with a product in which they take interest and pride in doing the job.
3. Greater flexibility with this type of layout.
4. Layout capital investment is lower.

### **4-3-5 - Group Layout (or Cellular Layout)**

There is a trend now to bring an element of *flexibility* into manufacturing system as regards to variation in batch sizes and sequence of operations. A grouping of equipment for performing a sequence of operations on family of similar components or products has become all the important.

Group Technology (GT) is the analysis and comparisons of items to group them into *families with similar characteristics*. GT can be used to develop a hybrid between pure process layout and pure flow line (product) layout. This technique is very useful for companies that produce variety of parts in small batches to enable them to take advantage and economics of flow line layout.

The application of group technology involves *two basic steps*; first step is to determine component families or groups. The second step in applying group technology is to arrange the plants equipment used to process a particular family of components. This represents small plants within the plants. The group technology reduces production planning time for jobs. It reduces the set-up time. Thus group layout is a combination of the product layout and process layout. It combines the advantages of both layout systems. If there are  $m$  -machines and  $n$  -components, in a group layout (Group-Technology Layout), the  $m$ -machines and  $n$ -components will be divided into distinct number of machine-component cells (group) such that all the components assigned to a cell are almost

processed within that cell itself. Here, the *objective is to minimize the inter-cell movements*.

The basic aim of a group technology layout is to identify families of components that require similar of satisfying all the requirements of the machines are grouped into cells. Each cell is capable of satisfying all the requirements of the component family assigned to it. See fig (4.5). In-group technology layout, the objective is to minimize the sum of the cost of transportation and the cost of equipments. So, this is called as multi-objective layout.

**Advantages of Group Technology Layout:**

Group Technology layout can **increase:**

1. Component standardization and rationalization.
2. Effective machine operation and productivity.
3. Customer service.

**It can decrease the:**

1. Paper work and overall production time.
2. Work-in-progress and work movement.
3. Overall cost.

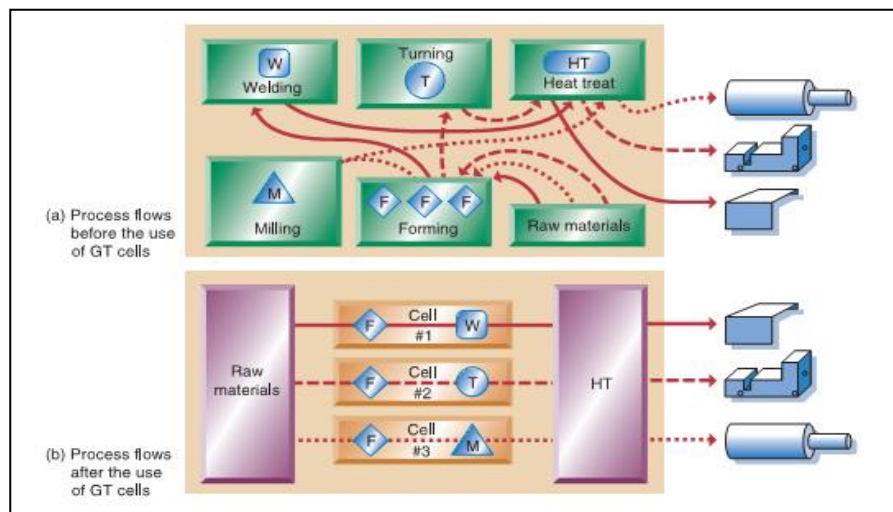

Fig. 4.5 Process flows before and after the use of GT

## 4-4- Types of Flow Patterns

### 4-4-1- Flow Patterns: Flow within Workstations

*Motion studies and ergonomics* considerations are important in establishing the flow within workstations. Flow within workstations should be:

- Simultaneous: coordinated use of hands, arms and feet.
- Symmetrical: coordination of movements about the center of the body.
- Natural: movements are continuous, curved, and make use of momentum.
- Rhythmical and Habitual: flow allows a methodological and automatic sequence of activities. It should reduce mental, eye and muscle fatigue, and strain.

### 4-4-2- Flow Patterns: Flow within Departments

- The flow pattern within departments depends on the type of department.
- In a product and/or product family department, the flow follows the product flow.
- In a process department, little flow should occur between workstations within departments.

### 4-4-3- Flow Pattern: Flow between Departments

- Flow between departments is a criterion often used to evaluate flow within a facility.
- Flow typically is a combination of the basic horizontal flow patterns shown below. An important consideration in combining the flow patterns is the location of the entrance (receiving department) and exit (shipping).

In the facilities layout problem, the decision regarding placement of the machines is typically made. Depending on the application and availability of space, the machines are placed in one of the following pattern:

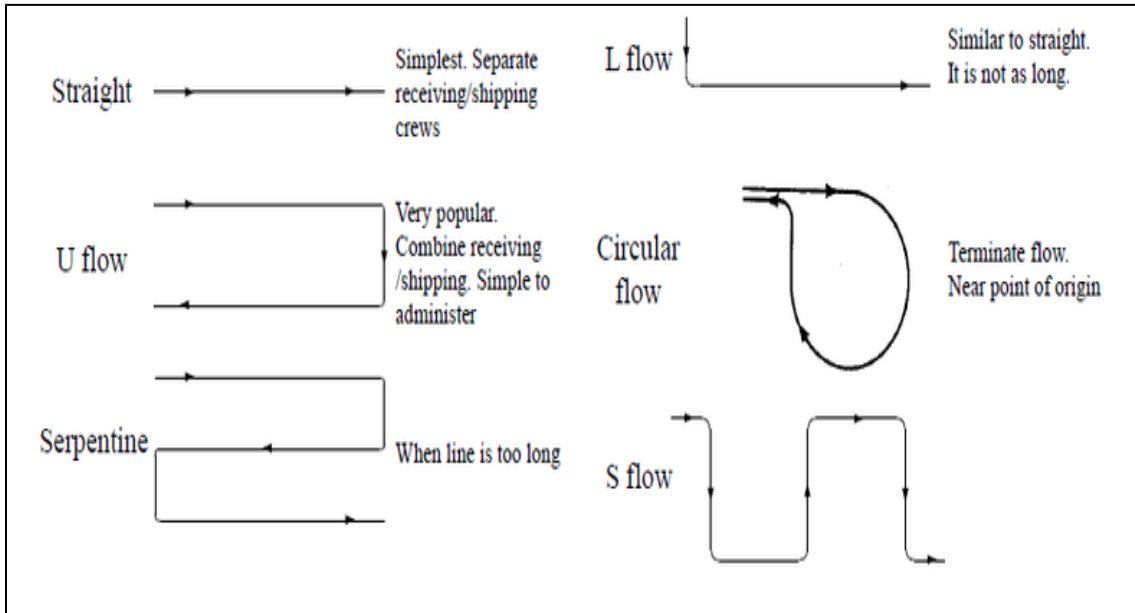

### Vertical Flow Pattern

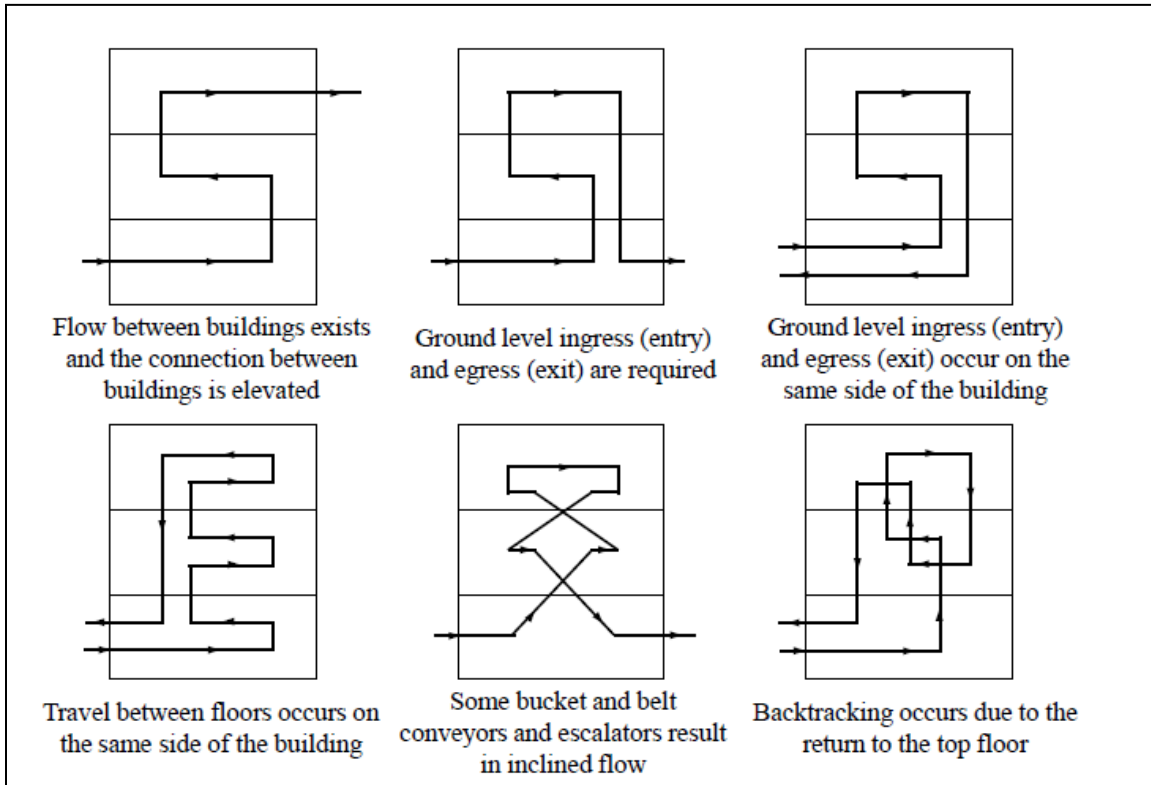

Table 4-2 The advantages and disadvantages of the basic layout types

	<i>Advantages</i>	<i>Disadvantages</i>
<b>Fixed-position</b>	Very high mix and product flexibility Product or customer not moved or disturbed High variety of tasks for staff	Very high unit costs Scheduling of space and activities can be difficult Can mean much movement of plant and staff
<b>Functional</b>	High mix and product flexibility Relatively robust in the case of disruptions Relatively easy supervision of equipment or plant	Low facilities utilization Can have very high work-in-progress or customer queuing Complex flow can be difficult to control
<b>Cell</b>	Can give a good compromise between cost and flexibility for relatively high-variety operations Fast throughput Group work can result in good motivation	Can be costly to rearrange existing layout Can need more plant and equipment Can give lower plant utilization
<b>Product</b>	Low unit costs for high volume Gives opportunities for specialization of equipment Materials or customer movement is convenient	Can have low mix flexibility Not very robust if there is disruption Work can be very repetitive

#### 4-5- DESIGNING PROCESS LAYOUTS

When designing a process layout, the most common tactic is to arrange departments or work centers so that the cost of material handling is minimum. For this, departments with large flows of parts or people between them should be placed next to one another. Material handling costs in this approach depend on:

- The number of loads or people to be moved between two departments during some period of time, and
- The distance linked costs of moving loads or people between departments. Cost is considered to be a function of distance between departments.

*The objective function can be written as follows:*

$$\text{Minimize cost} = \sum_{i=1}^n \sum_{j=1}^n X_{ij} C_{ij}$$

where  $n$  = total number of work centers or departments

$i, j$  = individual departments

$X_{ij}$  = number of loads moved from department  $i$  to department  $j$

$C_{ij}$  = cost to move a load between department  $i$  to department  $j$ .

The term  $C_{ij}$  combines distance and other costs into one factor. We thereby assume that the difficulty of movement is equal and the pickup and set down costs are constant.

**Example 4.1.** A company management wants to arrange the six departments of its factory in a way that will minimize interdepartmental material handling costs. They make an initial assumption (to simplify the problem) that each department is  $20 \times 20$  feet and that the building is 60 feet long and 40 feet wide. The process layout procedure that they follow involves six steps:

**Step-1:** Construct a ‘from-to-matrix’ showing the flow of parts or materials from department to department (see the Table).

Department	Assembly	Painting	Machine shop	Receiving	Shopping	Testing
Assembly (1)	$\alpha$	50	100	0	0	20
Painting (2)		$\alpha$	30	50	10	0
Machine shop (3)			$\alpha$	20	0	100
Receiving (4)				$\alpha$	50	0
Shopping (5)					$\alpha$	0
Testing (6)						$\alpha$

**Step-2:** Determine the space requirements for each department (Figure-3.5 shows the available plant space).

**Step-3:** Develop an initial schematic diagram showing the sequence of departments through which parts must move. Try to place departments with a heavy flow of materials or parts next to one another (Figure-3.6).

**Step-4:** Determine the cost of this layout by using the material handling cost equation:

$$\text{Cost} = \sum_{i=1}^n \sum_{j=1}^n X_{ij} C_{ij}$$

For this problem, the company assumes that a forklift carries all interdepartmental loads. The cost of moving one load between adjacent departments is estimated to be \$1. Moving a load between nonadjacent departments costs \$2. Thus, looking at Table 3.4, we see that the handling cost between departments 1 and 2 is \$50 (i.e., \$1 × 50 loads), the handling cost between departments 1 and 3 is \$200 (i.e., \$2x100 loads), and the handling cost between departments 1 and 6 is \$40 (i.e., \$2 × 20 loads), and so on. The total cost for this layout is shown in Table 3.5.

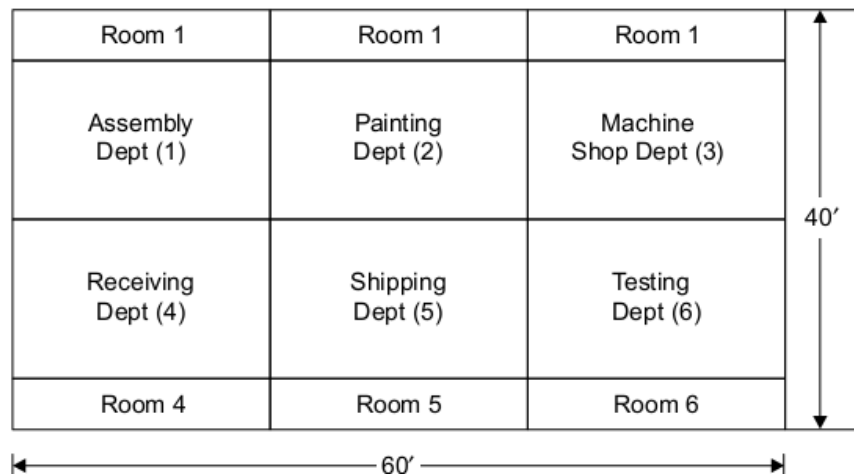

Figure 4.6. Building Dimensions and a Possible Layout.

**Step-5:** By trial and error, try to improve the layout shown in Figure-3.6 to establish a reasonably good arrangement of departments.

Table 4.5

<i>Movement Route</i>	<i>Cost for route (\$)</i>
1-2	$1 \times 50 = 50$
1-3	$2 \times 100 = 200$
1-6	$2 \times 20 = 40$
2-3	$1 \times 30 = 30$
2-4	$1 \times 50 = 50$
2-5	$1 \times 10 = 10$
3-4	$2 \times 20 = 40$
3-6	$1 \times 100 = 100$
4-5	$1 \times 50 = 50$
Total cost	570

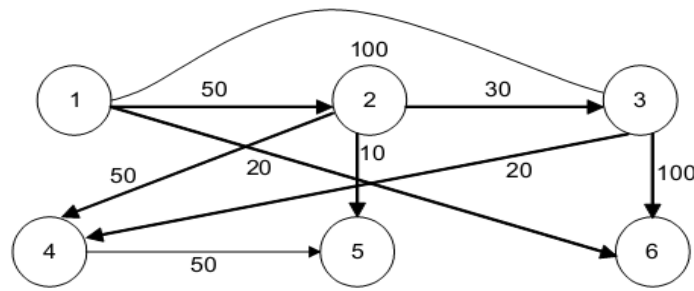

Figure 4.7. Interdepartmental flow graph with number of loads per week.

By looking at both the flow graph (Figure 4.7) and the cost calculations, it is obvious that placing departments 1 and 3 together seem desirable. They are presently nonadjacent, and due to the high volume of flow between them the material handling cost is high. One possibility is to exchange the position of 1 and 2. Doing this will change the cost which is shown in Table 4.6.



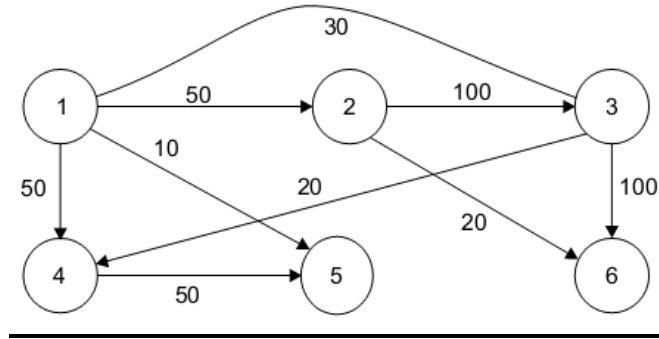

Figure 4.8. Second flow graph with number of loads per week.

Table 4.5

<i>Movement Route</i>	<i>Cost for route (\$)</i>
1-2	$1 \times 50 = 50$
1-3	$1 \times 100 = 100$
1-6	$1 \times 20 = 20$
2-3	$2 \times 30 = 60$
2-4	$1 \times 50 = 50$
2-5	$1 \times 10 = 10$
3-4	$2 \times 20 = 40$
3-6	$1 \times 100 = 100$
4-5	$1 \times 50 = 50$
<b>Total cost</b>	<b>480</b>

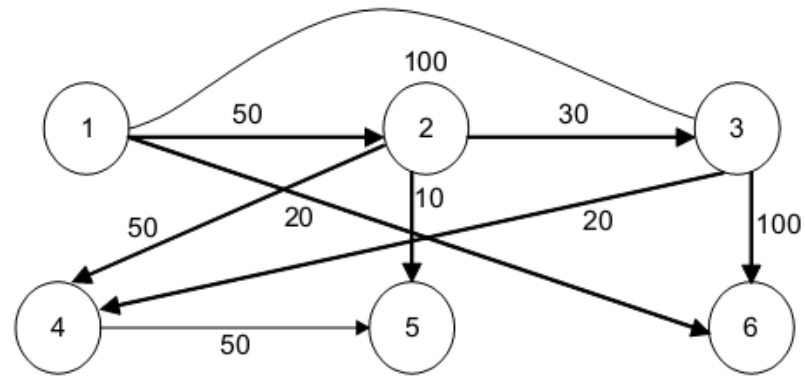

Figure 4.7. Interdepartmental flow graph with number of loads per week.

By looking at both the flow graph (Figure 4.7) and the cost calculations, it is obvious that placing departments 1 and 3 together seem desirable. They are presently nonadjacent, and due to the high volume of flow between them the material handling cost is high. One possibility is to exchange the position of 1 and 2. Doing this will change the cost which is shown in Table 4.6.

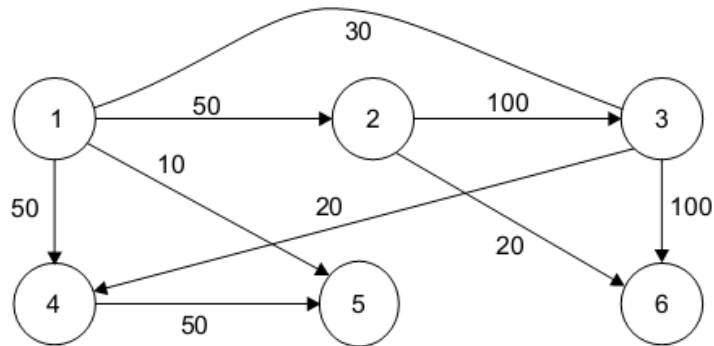

Figure 4.8. Second flow graph with number of loads per week.

Table 4.6

<i>Movement Route</i>	<i>Cost for route (\$)</i>
1-2	$1 \times 50 = 50$
1-3	$1 \times 100 = 100$
1-6	$1 \times 20 = 20$
2-3	$2 \times 30 = 60$
2-4	$1 \times 50 = 50$
2-5	$1 \times 10 = 10$
3-4	$2 \times 20 = 40$
3-6	$1 \times 100 = 100$
4-5	$1 \times 50 = 50$
<b>Total cost</b>	<b>480</b>

This change, of course, is just one of the many possible combinations. For a six-department problem, the possible combination is  $6! = 6 \times 5 \times 4 \times 3 \times 2 \times 1 =$

720. In layout problems, we seldom find the optimal solution and will have to be satisfied with a ‘reasonable’ one reached after a few trials.

We can try a few steps more to find a layout which is less expensive than the present one.

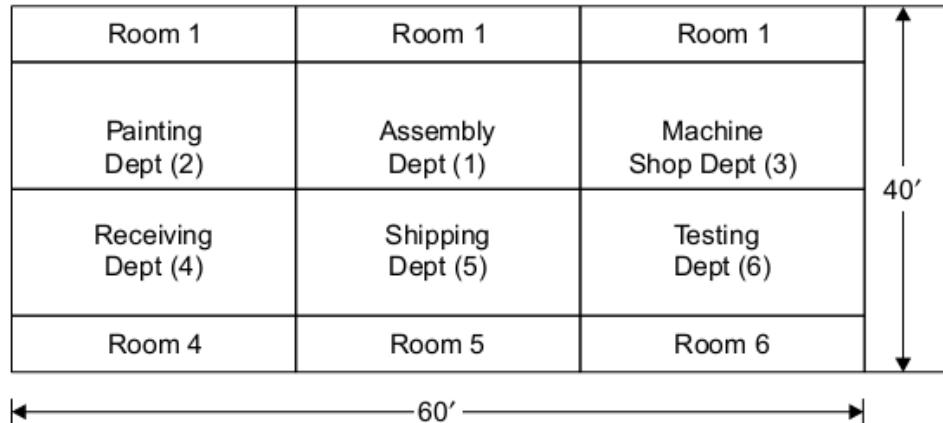

Figure 4.9. Feasible Layout for the company.

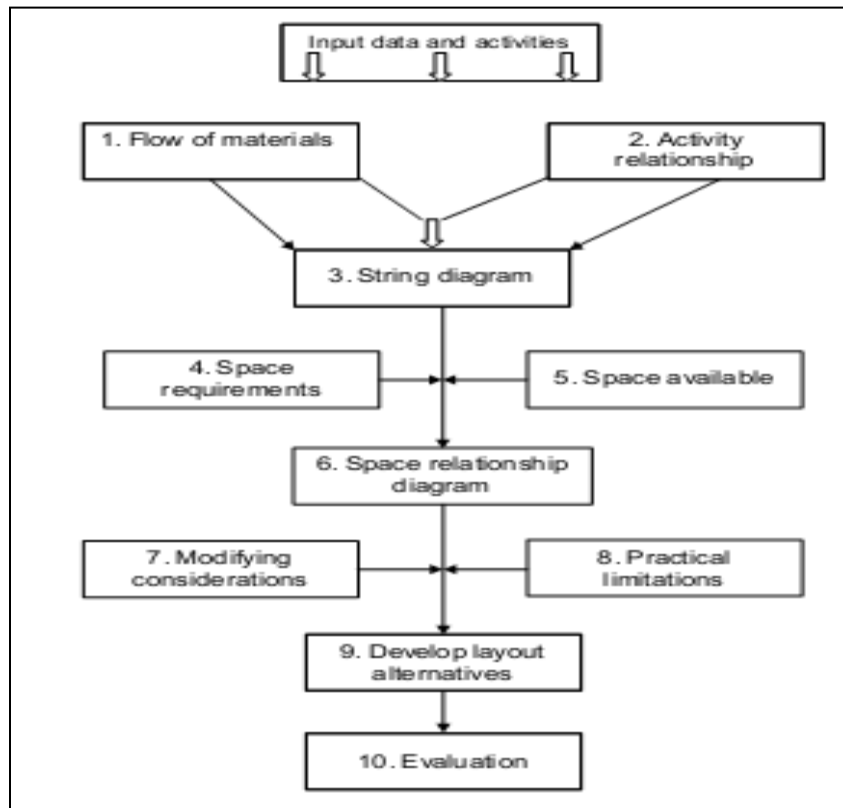

Figure 4.10. Systematic Layout Planning Procedure.

#### **4-6- The Systematic Layout Planning Procedure:**

1-Preparation phase: the following tools are used in the layout preparation phase:

- Graphic and schematic analysis: Perhaps the most common layout planning tools are templates—two dimensional cutouts of equipment drawn to scale.
- Operation Process Chart (OPC): operations, and inspections only
- Flow Process Chart (FPC): operations, inspections, transports, delays, and storage.
- Multiple-product Chart (MPC):
- From-To Chart (FTC) / or flow chart:

2. An ‘activity relationship diagram (ARD)’ shows the desired closeness of departments and areas within the plant. It reflects the fact that not all important relationships.

3. Step 3 consists of using the information generated in Steps 1 and 2 to prepare a string diagram showing near optimal placement of the facilities without considering the space constraints. The placement is done by trial and error. Usually, the areas with an A closeness are shown first and are connected with 4 straight lines, then E with 3 straight lines, and so on.

4. Step 4 may be called the ‘adjustment step’. Here the adjustment must be made for space needs as related to space availability; so, the space requirements have to be determined. This can be done through calculations, adjustments of past areas, intuition or estimates.

5. Once these space requirements are known, it is necessary to consider the space available. In some cases, since the layout must fit into the existing buildings, the space available is highly restricted.

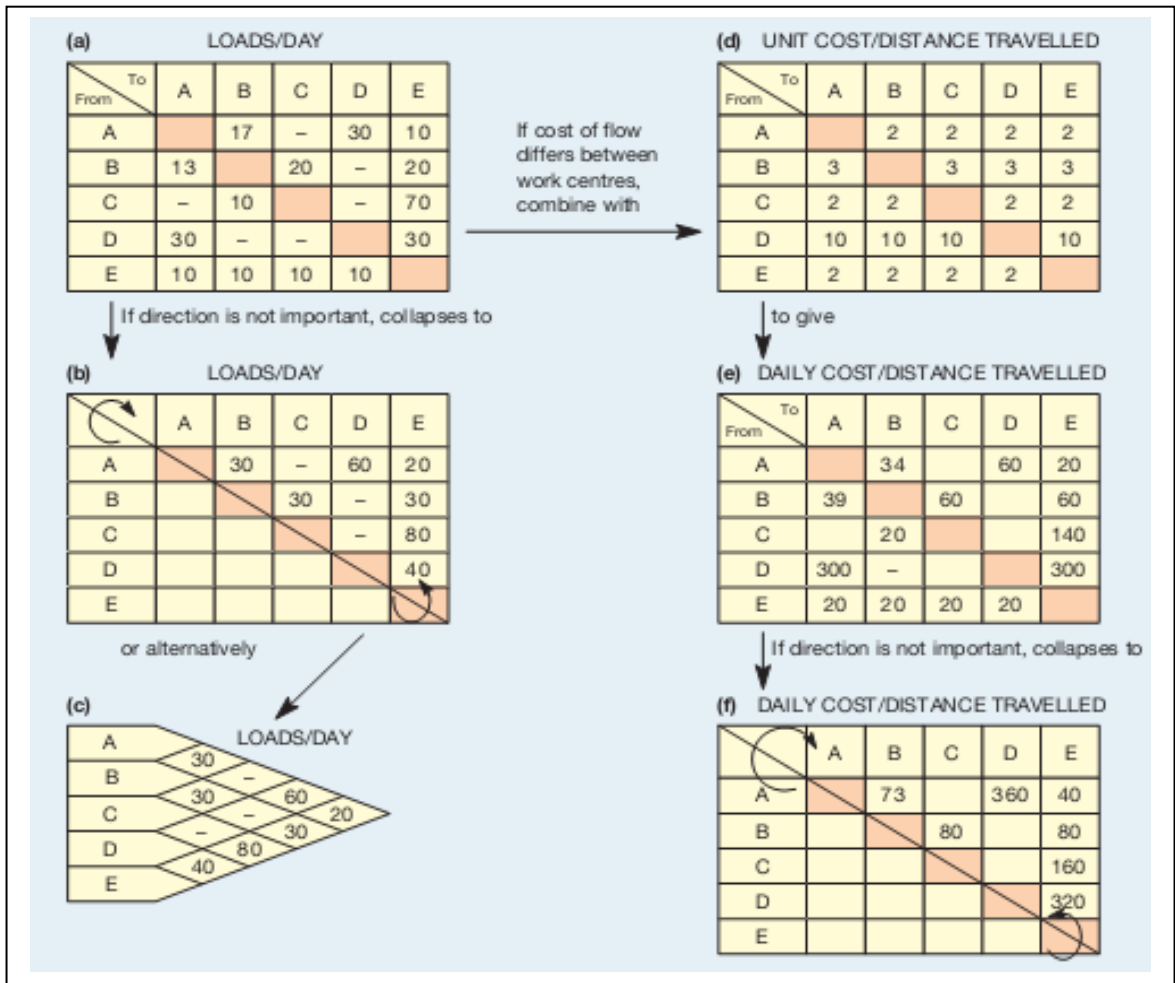

Figure 4.11 Collecting information in functional layout

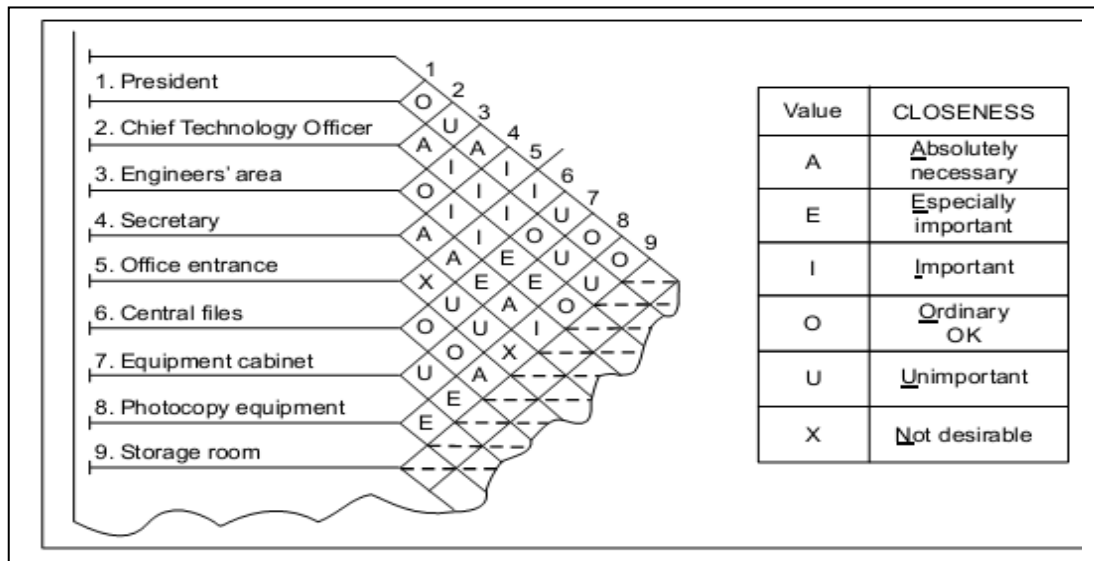

Figure 4.12. Relationship Chart for an Office