

UNIT 1 WORKSTUDY AND ERGONOMICS

1.0 WORK STUDY

- First technique applied for increasing productivity.
- Considered as a valuable tool in increasing productivity.

Definition: Work study is a generic term for the techniques of method study and work measurement.

These techniques are used in the examination of human work in all its contexts. They lead systematically to the investigation of all the factors which affect the efficiency and economy at the

work place in order to affect improvement.

1.1.METHOD STUDY

Method study is the technique of systematic recording and critical examination of existing and proposed ways of doing work and developing an easier and economical method.

1.1.1 Objectives of Method Study

1. Improvement of manufacturing processes and procedures.
2. Improvement of working conditions.
3. Improvement of plant layout and work place layout.
4. Reducing the human effort and fatigue.
5. Reducing material handling
6. Improvement of plant and equipment design.
7. Improvement in the utility of material, machines and manpower.
8. Standardisation of method.
9. Improvement in safety standard.

1.2. BASIC PROCEDURE FOR METHOD STUDY

The basic procedure for conducting method study is as follows:

1. Select the work to be studied.
2. Record all facts about the method by direct observation.
3. Examine the above facts critically.
4. Develop the most efficient and economic method.
5. Define the new method.
6. Install the new method
7. Maintain the new method by regular checking.

1. Select

While selecting a job for doing method study, the following factors are considered:

- (a) Economical factors.
- (b) Human factors.
- (c) Technical factors.

(a) Economical Factors

The money saved as a result of method study should be sufficiently more. Then only the study will

be worthwhile. Based on the economical factors, generally the following jobs are selected.

- (a) Operations having bottlenecks (which holds up other production activities).
- (b) Operations done repetitively.

-
- (c) Operations having a great amount of manual work.
 - (d) Operations where materials are moved for a long distance.

(b) Human Factors

The method study will be successful only with the co-operation of all people concerned viz., workers, supervisor, trade unions etc.

Workers may resist method study due to

1. The fear of unemployment.
2. The fear of reduction in wages.
3. The fear of increased work load.

then if they do not accept method study, the study should be postponed.

(c) Technical Factors

To improve the method of work all the technical details about the job should be available. Every machine tool will have its own capacity. Beyond this, it cannot be improved. For example, a work study man feels that speed of the machine tool may be increased and HSS tool may be used. But the capacity of the machine may not permit increased speed. In this case, the suggestion of the work study man cannot be implemented. These types of technical factors should be considered.

2. Record

All the details about the existing method are recorded. This is done by directly observing the work.

Symbols are used to represent the activities like operation, inspection, transport, storage and delay.

Different charts and diagrams are used in recording. They are:

1. Operation process chart: All the operations and inspections are recorded.
2. Flow process chart
 - (a) Man type All the activities of man are recorded
 - (b) Material type All the activities of the material are recorded
 - (c) Equipment type All the activities of equipment or machine are recorded.
3. Two-handed process chart: Motions of both hands of worker are Right hand-Left hand chart recorded independently.
4. Multiple activity chart: Activities of a group of workers doing a single job or the activities of a single worker operating a number of machines are recorded.
5. Flow diagram: This is drawn to suitable scale. Path of flow of material in the shop is recorded.
6. String diagram: The movements of workers are recorded using a string in a diagram drawn to scale.

3. Examine

Critical examination is done by questioning technique. This step comes after the method is recorded by suitable charts and diagrams.

The individual activity is examined by putting a number of questions. The following factors are questioned

-
1. Purpose – To eliminate the activity, if possible.
 2. Place – To combine or re-arrange the activities.
 3. Sequence – -do-
 4. Person – -do-
 5. Means – To simplify the activity.

The following sequence of questions is used:

1. Purpose – What is actually done?
Why is it done?
What else could be done?
What should be done?
2. Place – Where is it being done?
Why is it done there?
Where else could it be done?
Where should it be done?
3. Sequence – When is it done?
Why is it done then?
When could it be done?
When should it be done?
4. Person – Who is doing it?
Why does that person do it?
Who else could do it?
Who should do it?
5. Means – How is it done?
Why is it done that way?
How else could it be done?
How should it be done?

By doing this questioning

- Unwanted activities can be eliminated
- Number of activities can be combined or re-arranged
- Method can be simplified.

All these will reduce production time.

4. Develop

The answer to the questions given below will result in the development of a better method.

1. Purpose – What should be done?
2. Place – Where should it be done?
3. Sequence – When should it be done?
4. Person – Who should do it?
5. Means – How should it be done?

5. Define

Once a complete study of a job has been made and a new method is developed, it is necessary to obtain the approval of the management before installing it. The work study man should prepare a report giving details of the existing and proposed methods. He should give his reasons for the changes

suggested. The report should show

- (a) Brief description of the old method.

-
- (b) Brief description of the new method.
 - (c) Reasons for change.
 - (d) Advantages and limitations of the new method.
 - (e) Savings expected in material, labour and overheads.
 - (f) Tools and equipment required for the new method.
 - (g) The cost of installing the new method including.
 1. Cost of new tools and equipment.
 2. Cost of re-layout of the shop.
 3. Cost of training the workers in the new method.
 4. Cost of improving the working conditions.

Written standard practice: Before installing the new method, an operator's instructions sheet called written standard practice is prepared. It serves the following purposes:

1. It records the improved method for future reference in as much detail as may be necessary.
2. It is used to explain the new method to the management foreman and operators.
3. It gives the details of changes required in the layout of machine and work places.
4. It is used as an aid to training or retraining operators.
5. It forms the basis for time studies.

The written standard practice will contain the following information:

- (a) Tools and equipment to be used in the new method.
- (b) General operating conditions.
- (c) Description of the new method in detail.
- (d) Diagram of the workplace layout and sketches of special tools, jigs or fixtures required.

6. Install

This step is the most difficult stage in method study. Here the active support of both management and trade union is required. Here the work study man requires skill in getting along with other people and winning their trust. Instal stage consists of

- (a) Gaining acceptance of the change by supervisor.
- (b) Getting approval of management.
- (c) Gaining the acceptance of change by workers and trade unions.
- (d) Giving training to operators in the new method.
- (e) To be in close contact with the progress of the job until it is satisfactorily executed.

7. Maintain

The work study man must see that the new method introduced is followed. The workers after some time may slip back to the old methods. This should not be allowed. The new method may have defects. There may be difficulties also. This should be rectified in time by the work study man. Periodical review is made. The reactions and suggestions from workers and supervisors are noted. This may lead to further improvement. The differences between the new written standard practice and the actual practice are found out. Reasons for variations are analysed. Changes due to valid reasons are accepted. The instructions are suitably modified.

1.3 CHARTS AND DIAGRAMS USED IN METHOD STUDY (TOOLS AND TECHNIQUES)

As explained earlier, the following charts and diagrams are used in method study.

1. Operation process chart (or) Outline process chart.

2. Flow process chart.
 - (a) Material type
 - (b) Operator type
 - (c) Equipment type
3. Two-handed process chart. (or) Left hand-Right hand chart
4. Multiple activity chart.
5. Flow diagram.
6. String diagram.

1.3.1 Process Chart Symbols

The recording of the facts about the job in a process chart is done by using standard symbols.

Using of symbols in recording the activities is much easier than writing down the facts about the job. Symbols are very convenient and widely understood type of short hand. They save a lot of writing and indicate clearly what is happening.

1. Operation

A large circle indicates operation. An operation takes place when there is a change in physical or chemical characteristics of an object. An assembly or disassembly is also an operation.

When information is given or received or when planning or calculating takes place it is also called operation.

Example 1.1

Reducing the diameter of an object in a lathe. Hardening the surface of an object by heat treatment.

2. Inspection

A square indicates inspection. Inspection is checking an object for its quality, quantity or identifications.

Example 1.2

Checking the diameter of a rod. Counting the number of products produced.

3. Transport

An arrow indicates transport. This refers to the movement of an object or operator or equipment from one place to another. When the movement takes place during an operation, it is not called transport.

Example 1.3

Moving the material by a trolley
Operator going to the stores to get some tool.

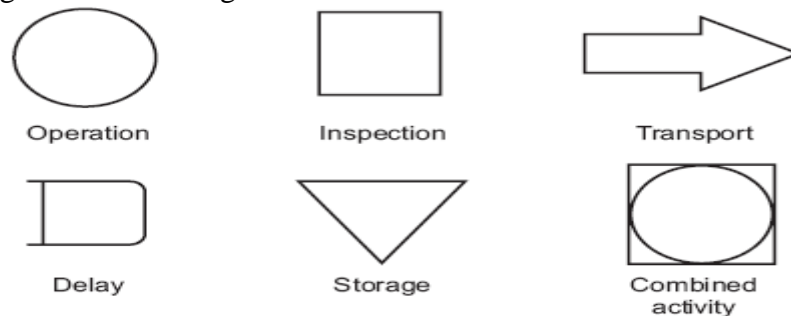

Fig. 1.1: Process chart symbols

4. Delay or temporary storage

A large capital letter D indicates delay. This is also called as temporary storage. Delay occurs when an object or operator is waiting for the next activity.

Example 1.4

An operator waiting to get a tool in the stores. Work pieces stocked near the machine before the next operation.

10 Process Planning and Cost Estimation

5. Permanent storage

An equilateral triangle standing on its vertex represents storage. Storage takes place when an object

is stored and protected against unauthorized removal.

Example 1.5

Raw material in the store room.

6. Combined activity

When two activities take place at the same time or done by the same operator or at the same place, the two symbols of activities are combined.

Example 1.6

Reading and recording a pressure gauge. Here a circle inside a square represents the combined activity of operation and inspection.

1.3.2 Operation Process Chart

An operation process chart is a graphic representation of the sequence of all operations and inspections taking place in a process. It is also known as outline process chart. It gives a bird's eye view of the overall activities. Entry points of all material are noted in the chart.

An example of operation process chart is shown in the figure 1.2. Here the process of manufacture of electric motor is shown.

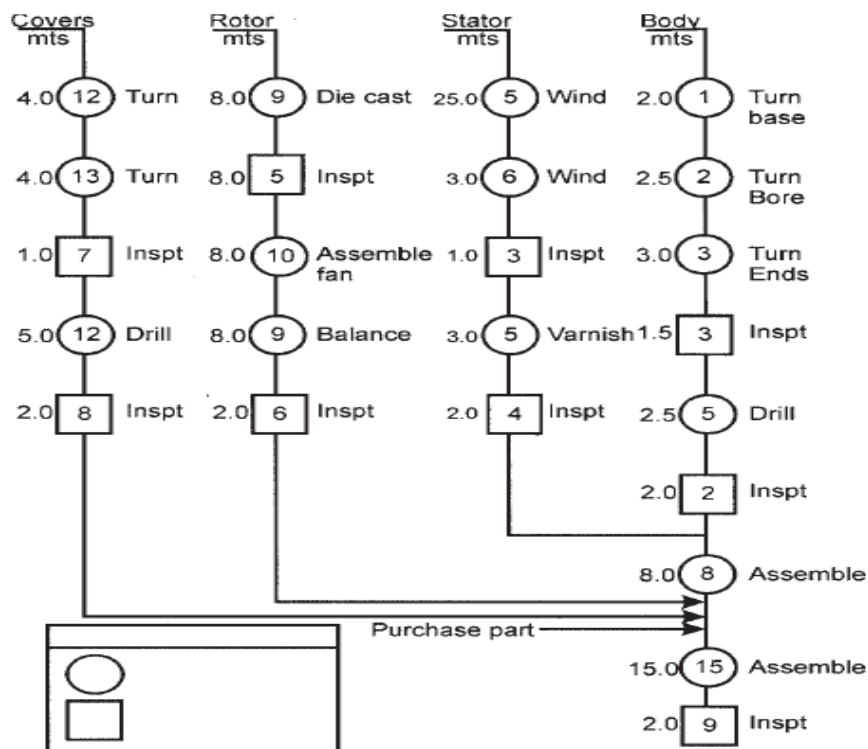

Fig. 1.2: Operation process chart

The conventions followed in preparing the chart are

1. Write title at the top of the chart.
2. Begin the chart from the right hand side top corner.
3. Represent the main component at the right extreme.
4. Represent the sequence of operations and inspections by their symbols. Connect them

by

vertical flow lines.

5. Record the brief description of the activity to the right side of the symbols.
6. Note down the time for each activity to the left of the symbol.
7. Number all operations in one serial order. Start from the right hand top (from number 1).
8. Similarly number all inspections in another serial order (starting from 1).
9. Continue numbering, till the entry of the second component.
10. Show the entry of purchased parts by horizontal lines.

1.3.3 Flow Process Chart

A flow process chart is a graphical representation of the sequence of all the activities (operation, inspection, transport, delay and storage) taking place in a process. Process chart symbols are used

here to represent the activities. There are three types of flow process charts. They are

1. Man type flow process chart

This flow process chart records what the worker does.

2. Material type flow process chart

This flow process chart records how the material is handled or treated.

3. Equipment type flow process chart

This flow process chart records how the equipment or machine is used.

Example 1.7

The activities of a stenographer in preparation of a letter are recorded in the operator type flow process chart shown in figure 1.3.

Chart No. : 001		Date :			
Job : Typing A letter		Charted by:			
Chart begins : Steno in her seat		Chart ends-putting the typed letter in the way			
Method : Present/Proposed					
Sl. No.	Description of the activities	Distance	Time in Sec.	Symbols	Remarks
1.	Steno in her seat	-	-	O □ ⇒ D ▽	
2.	Hears the bell	-	3		
3.	Goes to manager's room	6m	10		
4.	Takes down dictation	-	120		
5.	Returns to her seat	6m	10		
6.	Prepares typewriter	-	15		
7.	Types the letter	-	150		
8.	Checks the matter	-	40		
9.	Goes to manager's room	6m	10		
10.	Waits till the manager signs	-	20		
11.	Returns to her seat	6m	10		
12.	Types envelope	-	20		
13.	Puts the letter inside envelope	-	5		
14.	Puts the envelope in dispatch tray	-	5		

Fig. 1.3: Flow process chart—operator type

The chart records the activities of the steno. Here, the manager calls the steno and dictates a letter. The steno takes notes of the letter, types it, gets the signature of the manager and sends it for dispatching. These activities are shown in the chart. This is operator type flow process chart. Considering the message in the letter as material, we can prepare the material type flow process chart.

General guidelines for making a flow process chart

1. The details must be obtained by direct observation—charts must not be based on memory.
2. All the facts must be correctly recorded.
3. No assumptions should be made.
4. Make it easy for future reference.
5. All charts must have the following details:
 - (a) Name of the product, material or equipment that is observed.
 - (b) Starting point and ending point.
 - (c) The location where the activities take place.
 - (d) The chart reference number, sheet number and number of total sheets.
 - (e) Key to the symbols used must be stated.

1.3.4 Two-Handed Process Chart (or) Right Hand, Left Hand Chart

- It is the process chart in which the activities of two hands of the operator are recorded.
- It shows whether the two hands of the operator are idle or moving in relation to one another, in a timescale.
- It is generally used for repetitive operations.

Operation: Represents the activities grasp, position, use, release etc. of a tool, component or material.

Transport: Represents the movement of the hand or limb to or from the work or a tool or material.

Delay: Refers to the time when the hand or limb is idle.

Storage (Hold): The term 'hold' is used here instead of storage. This refers to the time when the work is held by hand.

The activity 'inspection' by hand is considered as an operation. Hence, the symbol for inspection is not used in this chart.

Two-handed process chart can be used for assembly, machining and clerical jobs.

General guidelines for preparing the chart

1. Provide all information about the job in the chart.
2. Study the operation cycle a few times before starting to record.
3. Record one hand at a time.
4. First record the activities of the hand which starts the work first.
5. Do not combine the different activities like operations, transport etc.

Example 1.8

Example of a two-handed process chart is shown in figure 1.4. Here the assembly of a nut

and washer over a bolt is recorded.

The work place layout is shown in the right hand corner. The activities of left hand are recorded

at left half of the chart. The activities of the right hand are recorded at the right half of the chart.

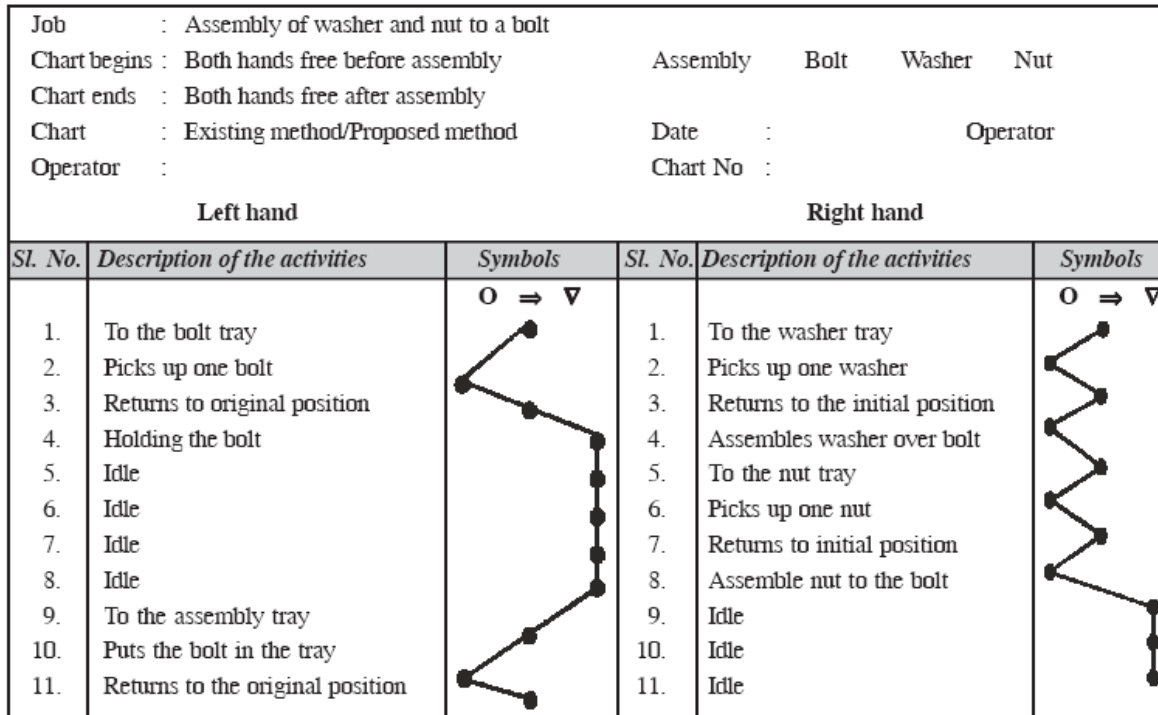

Fig. 1.4: Two-handed process chart

The horizontal lines represent the time scale. Activities of left hand and right hand shown in the same line occur at the same moment.

Summary of the number of each activity can be tabulated at the bottom of the chart. The chart is first drawn for the existing method. This chart is analysed and if it is found that one hand is over loaded than the other, modification are done in the layout of the workplace or in the sequence of activities. Then a new chart is made for the proposed cycle.

1.3.5 Man-Machine Chart

A man-machine chart is a chart in which the activities of more than one worker or machine are recorded. Activities are recorded on a common time scale to show the inter-relationship. It is also known as multiple activity chart.

It is used when a worker operates a number of machines at a time. It is also used when a number of workers jointly do a job.

Activities of workers or machines are recorded in separate vertical columns (bars) with a horizontal time scale.

The chart shows the idle time of the worker or machine during the process. By carefully analyzing the chart, we can rearrange the activities. Work load is evenly distributed among the workers or machines by this the idle time of worker or machine is reduced. Multiple activity chart is very useful in planning team work in production or maintenance. Using the chart we can

find out the correct number of machines that a worker can operate at a time. We can also find out the exact number of workers needed to do a job jointly.

To record the time, ordinary wrist watch or stop watch is used. High accuracy is not needed. Man-machine chart is a type of multiple activity chart. Here, the activities of a number of machines are recorded.

An example of man-machine chart is shown in figure 1.5. Here one operator two semi-automatic machines simultaneously. The activities of the operator is recorded in a separate vertical column. The activities of the two machines are recorded in two separate vertical columns. The different activities like loading, machining and unloading are represented by different symbols. Blank space shows the idle time.

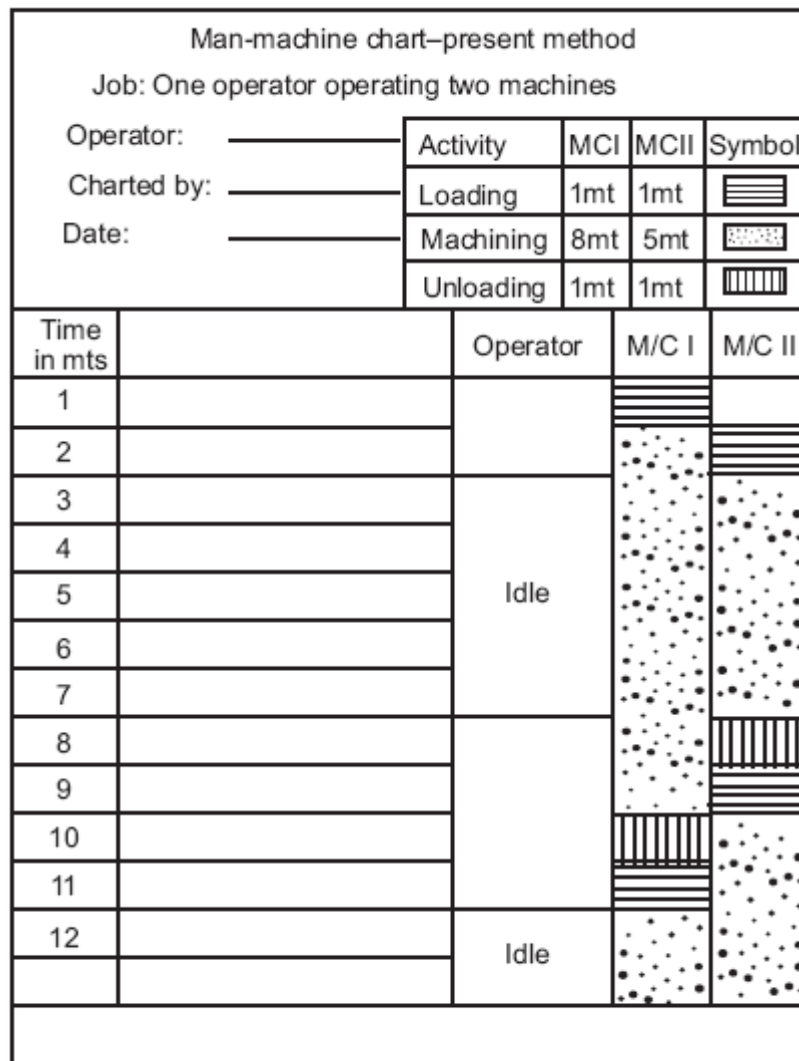

Fig. 1.5: Man-machine chart

1.3.6 Flow Diagram

In any production shop, repair shop or any other department, there are movements of men and material from one place to another. Process charts indicate the sequence of activities. They do not show the frequent movements of men and material. If these movement are minimized, a lot

of savings can be achieved in cost and effort. If the path of movement of material is not frequent and simple, a flow diagram is used for recording the movement.

A flow diagram is a diagram which is drawn to scale. The relative position of machineries, gang ways, material handling equipment etc. are drawn first. Then the path followed by men or material is marked on the diagram. Different movements can be marked in different colours. Process symbols are added to the diagram to identify the different activities at different work centres.

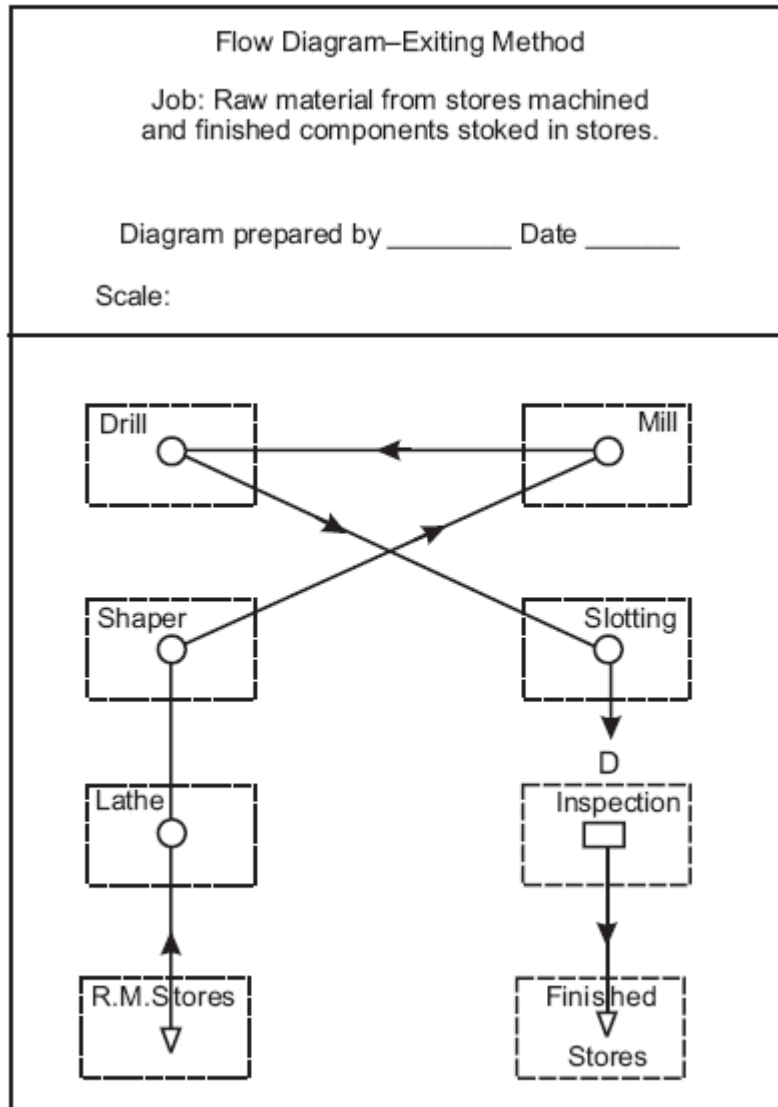

Fig. 1.6: Flow diagram

The flow diagram are used for the following purposes:

1. To remove unwanted material movement.
2. To remove back tracking.
3. To avoid traffic congestion.
4. To improve the plant layout.

Conventions adopted are

1. Heading and description of the process should be given at the top of the diagram.

2. Other informations like location, name of the shop, name of the person drawing the diagram are also given.
3. The path followed by the material is shown by a flow line.
4. Direction of movement is shown by small arrows along the flow lines.
5. The different activities are represented by the symbols on the flow lines. (Same symbols used in flow process chart are used here).
6. If more than one product is to be shown in the diagram different colours are used for each path.

1.3.7 String Diagram

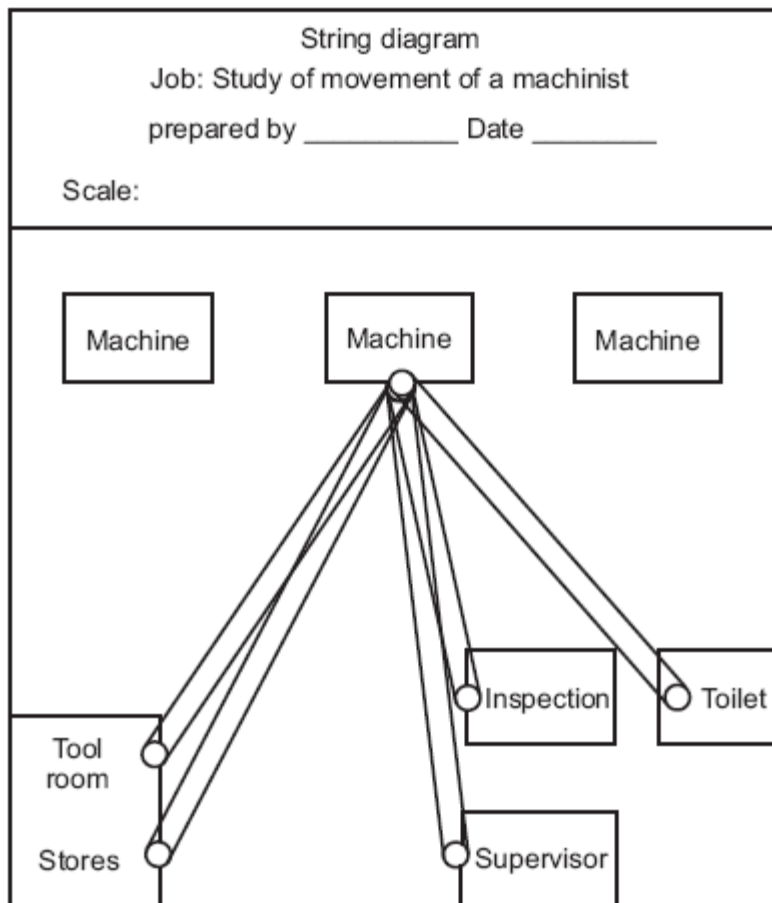

Fig. 1.7: String diagram

We make use of flow diagram for recording the movement of men or material when the movement is simple and the path is almost fixed. But when the paths are many and are repetitive, it may not be possible to record them in a flow diagram. Here a string diagram is used.

String diagram is a scaled plan of the shop. Location of machines and various facilities are drawn to scale in a drawing sheet. Pins are fixed at the various work centres in the drawing sheet. A continuous coloured thread or string is taken round the pins where the material or worker moves during the process.

Constructions

1. Draw the layout of the shop to scale in a drawing sheet.

-
2. Mark the various work centres like machines, stores, work bench etc. in the diagram.
 3. Hold the drawing sheet on a soft board and fix pins at the work centres.
 4. Tie one end of a coloured string to the work centre from which the movement starts.
 5. Follow the path of the worker to different work centre and accordingly take the thread to different points on the drawing board.
 6. At the end of the session note down the number of movements from one work centre to another.
 7. Remove the string and measure the total length of the string. Multiply by the scale and get the actual distance of movement.

Applications

1. It is used for recording the complex movements of material or men.
2. Back tracking, congestion, bottlenecks, under utilized paths are easily found out.
3. It is used to check whether the work station is correctly located.
4. Used to record irregular movements.
5. Used to find out the most economical route.

1.4 WORK MEASUREMENT

Work measurement is a technique to establish the time required for a qualified worker to carry out a specified job at a defined level of performance.

Objectives of work measurement

1. To reduce or eliminate non-productive time.
2. To fix the standard time for doing a job.
3. To develop standard data for future reference.
4. To improve methods.

Uses of work measurements

1. To compare the efficiency of alternate methods. When two or more methods are available for doing the same job, the time for each method is found out by work measurement. The method which takes minimum time is selected.

2. Standard time is used as a basis for wage incentive schemes.

3. It helps for the estimation of cost. Knowing the time standards, it is possible to work out the cost of the product. This helps to quote rates for tenders.

4. It helps to plan the workload of man and machine.

5. It helps to determine the requirement of men and machine. When we know the time to produce one piece and also the quantity to be produced, it is easy to calculate the total requirement of men and machines.

6. It helps in better production control. Time standards help accurate scheduling. So the production control can be done efficiently.

7. It helps to control the cost of production. With the help of time standards, the cost of production can be worked out. This cost is used as a basis for control.

8. It helps to fix the delivery date to the customer. By knowing the standard time we will be able to calculate the time required for manufacturing the required quantity of products.

1.5 TECHNIQUES OF WORK MEASUREMENT

The different techniques used in work measurement are

1. Stop watch time study.
2. Production study.
3. Work sampling or Ratio delay study.

-
4. Synthesis from standard data.
 5. Analytical estimating.
 6. Predetermined motion time system.

1.5.1 Stop Watch Time Study

Stop watch time study is one of the techniques of work measurement commonly used. Here we

make use of a stop watch for measuring the time.

Procedure for conducting stop watch time study

The following procedure is followed in conducting stop watch time study:

1. Selecting the job.
2. Recording the specifications.
3. Breaking operation into elements.
4. Examining each element.
5. Measuring using stop watch.
6. Assessing the rating factor.
7. Calculating the basic time.
8. Determining the allowances.
9. Compiling the standard time.

1. Selection of job

Time study is always done after method study. Under the following situations, a job is selected for time study:

1. A new job, new component or a new operation.
2. When new time standard is required.
3. To check the correctness of the existing time standard.
4. When the cost of operation is found to be high.
5. Before introducing an incentive scheme.
6. When two methods are to be compared.

2. Record

The following informations are recorded

1. About the product-name, product-number, specification.
2. About the machine, equipment and tools.
3. About the working condition-temperature-humidity-lighting etc. These informations are used when deciding about the allowances.
4. About the operator name-experience-age etc. This is needed for rating the operator.

3. Break down operation into elements

Each operation is divided into a number of elements. This is done for easy observation and accurate measurement. The elements are grouped as constant element, variable element, occasional element, man element, machine element etc.

4. Examine each element

The elements are examined to find out whether they are effective or wasteful. Elements are also examined whether they are done in the correct method.

5. Measure using a stop watch

The time taken for each element is measured using a stop watch. There are two methods of measuring, viz., Fly back method and Cumulative method. Cumulative method is preferable. The time measured from the stop watch is known as observed time. Time for various groups of elements should be recorded separately. This measurement has to be done for a number of times. The number of observations depend upon the type of operation, the accuracy required and time for one cycle.

6. Assess the rating factor

Rating is the measure of efficiency of a worker. The operator's rating is found out by comparing his speed of work with standard performance. The rating of an operator is decided by the work study man in consultation with the supervisor. The standard rating is taken as 100. If the operator is found to be slow, his rating is less than 100 say 90. If the operator is above average, his rating is more than 100, say 120.

7. Calculate the basic time

Basic time is calculated as follows by applying rating factor

$$\text{Basic time} = \text{Observed time} \times \frac{\text{Operator rating}}{\text{Standard rating}}$$

$$\text{BT} = \text{OT} \times \frac{\text{OR}}{\text{SR}}$$

8. Determine the allowance

A worker cannot work all the day continuously. He will require time for rest going for toilet, drinking water etc. Unavoidable delays may occur because of tool breakage etc. So some extra time is added to the basic time. The extra time is known as allowance.

9. Compile the standard time

The standard time is the sum of basic time and allowances. The standard time is also known as allowed time.

1.5.1.1 Breaking a Job into Elements

It is necessary to break down a task (job) into elements for the following reasons:

1. To separate productive time and unproductive time.
2. To assess the rating of the worker more accurately.
3. To identify the different types of elements and to measure their timings separately.
4. To determine the fatigue allowance accurately.
5. To prepare a detailed work specification.
6. To fix standard time for repetitive elements (such as switch on or switch off of machine).

Classification of elements

1. Repetitive elements

It is an element which occurs in every work cycle of the job.

Example 1.9

Loading the machine, locating a job in a fixture.

2. Constant element

It is an element for which the basic time remains constant whenever it is performed.

Example 1.10

Switching on the machine, switching off the machine.

3. Variable element

It is an element for which the basic time varies depending on the characteristics of the product, equipment or process.

Example 1.11

Saving a log of wood-time changes with diameter or the work.

4. Occasional element

It is an element which does not occur in every work cycle of the job. It may occur at regular or irregular intervals.

Example 1.12

Regrinding of tools, re-setting of tools.

5. Foreign element

It is an element which is not a part of the job.

Example 1.13

Cleaning a job that is to be machined.

6. Manual element

It is an element performed by the worker.

Example 1.14

Cleaning the machine, loading the machine.

7. Machine element

It is the element automatically performed by a power driven machine.

Example 1.15

Turning in a lathe using automatic feed.

General rules to be followed in breaking down a task into elements

1. Element should have a definite beginning and ending.
2. An element should be as short as possible so that it can be conveniently timed.
The shortest element that can be timed using a stop watch is 0.04 mt.
3. Manual elements and machine elements should be separately timed.
4. Constant element should be separated from variable elements.
5. Occasional and foreign elements should be timed separately.

1.5.1.2 Measuring Time with a Stop Watch

There are two methods of timing using a stop watch. They are

1. Fly back or Snap back method.
2. Continuous or Cumulative method.

1. Fly back method

Here the stop watch is started at the beginning of the first element. At the end of the element the reading is noted in the study sheet (in the WR column). At the same time, the stop watch hand is snapped back to zero. This is done by pressing down the knob, immediately the knob is released. The hand starts moving from zero for timing the next element. In this way the timing for each element is found out. This is called observed time (O.T.) .

2. Continuous method

Here the stop watch is started at the beginning of the first element. The watch runs continuously

throughout the study. At the end of each element the watch readings are recorded on the study sheet. The time for each element is calculated by successive subtraction. The final reading of the stop watch gives the total time. This is the observed time (O.T.).

1.6 CALCULATION OF BASIC TIME

Basic time is the time taken by an operator of standard performance (rating of 100). A man whose work is observed, may be a slow worker or a fast worker. His rating may be less than 100 or above 100. The observed time cannot be taken as the basic time. Here the rating factor is applied and basic time is calculated as follows.

$$\text{Basic time} = \text{Observed time} \times \frac{\text{Operator rating}}{\text{Standard rating}}$$

For example, assume that observed time for an operation is 0.7 mts. The rating of the operator is found to be 120.

$$\text{The Basic Time or Normal Time} = 0.7 \times \frac{120}{100} = 0.84 \text{ mts.}$$

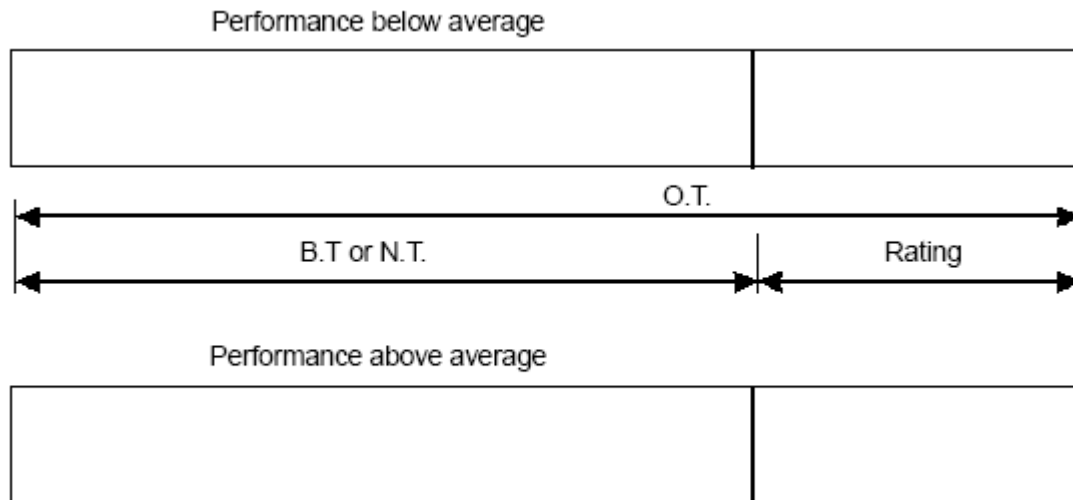

Fig. 1.8: Basic time calculation

1.7 ALLOWANCES

Various types of allowance are

1. Rest and personal allowance.
2. Process allowance.
3. Contingency allowance.
4. Special allowance.
5. Policy allowance.

1.8 CALCULATION OF STANDARD TIME

Standard time or allowed time is the total time in which a job should be completed at standard performance. It is the sum of normal time (basic time) and allowances. Policy allowance is not included.

Standard time is worked out in a stop watch time study in the following manner.

Observed time

This is the actual time observed by using a stop watch. The observed time of an operation is the total of the elemental times.

The time study for the same job is conducted for a number of times. The average of the observed times is calculated.

Basic or normal time

Basic time is the time taken by a worker with standard performance. Basic time is calculated from the observed time by applying the rating factor.

Basic time or

$$\text{Normal time} = \text{Observed time} \times \frac{\text{Rating of the operator}}{\text{Standard rating (100)}}$$

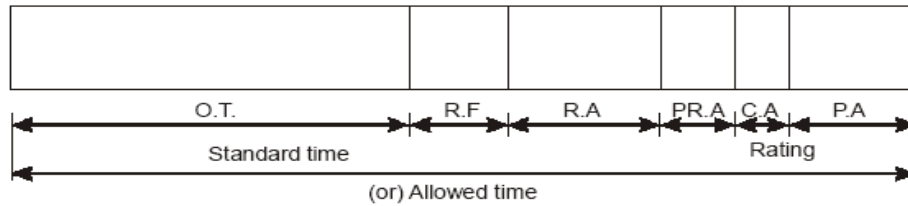

OT - Observed time
RF - Rating factor
RA - Rest allowance

PRA - Process allowance
CA - Contingency allowance
PA - Policy allowance

Fig. 1.9

Allowed time or standard time

The standard time is obtained by adding the following allowances with the basic or normal time.

1. Rest and personal allowance or relaxation allowance.
2. Process allowance or unavoidable delay allowance.
3. Contingency allowance.
4. Special allowance.

Policy allowance may be added to the standard time if the management wants.

1.9 PRODUCTION STUDY

Production study is a technique of work measurement to check accuracy of the original time study. This study is done to find the time delay due to occasional elements. These elements may occur at irregular intervals. Example: Tool grinding, setting tools etc. There are chances of missing these elements in the stop watch time study. Production study is conducted for a longer period—at least for half a day or one shift.

1.10 RATIO DELAY STUDY

This study is also known as work sampling or activity sampling. Here the ratio of the delay time and working time to the total time of an activity is found out. This is done by random (irregular) observations. This study is applied to

1. Long cycle operations.
2. Activities where time study is not possible.

1.11 SYNTHESIS FROM STANDARD DATA

Synthesis is a work measurement technique to work out standard time for a job by totaling the elemental times already obtained from previous time studies. Many operators in an industry have several common elements. Example: starting the machine, stopping the machine etc. Whenever these activities occur, they take the same duration of time. These elements are called constant elements. Time for some elements vary proportionately with the speed, feed, length of cut etc. in machining operation. These elements are known as variable elements. Time for all these constant elements and variable elements are collected from the time studies previously

made. These are stored in a file. This is called time standard data bank. Data bank contains data in the form of

1. Tabulated standard time for constant elements.
2. Charts and graphs.
3. Formulae etc.

1.12 ANALYTICAL ESTIMATING

Setting the time standards for long and non-repetitive operations by stop watch method are uneconomical. Analytical estimating technique determines the time values for such jobs either by using the synthetic data or on the basis of the past experience of the estimator when no synthetic or standard data is available. In order to produce accurate results the estimator must have sufficient experience of estimating, motion study, time study and the use of synthesized time standards.

1.13 PREDETERMINED MOTION TIME SYSTEM (PMTS)

Definition: PMTS is a work measurement technique where by times, established for basic human motions (classified according to the nature of the motion and the conditions under which it is made) are used to build up the time for a job at a defined level of performance. Few well-known systems using this concept are

1. M.T.M. : Method Time Measurement.
2. W.F.S. : Work Factor System.
3. M.T.A. : Motion Time Analysis.
4. D.M.T. : Dimensional Motion Times.
5. B.M.T. : Basic Motion Times.

1.14 ERGONOMICS

Ergonomics means 'work' and Nomos means 'Natural laws'. Ergonomics or its American equivalent 'Human Engineering' may be defined as the scientific study of the relationship between man and his working environments. Ergonomics implies 'Fitting the job to the worker'. Ergonomics combines the knowledge of a psychologist, physiologist, anatomist, engineer, anthropologist and a biometrician.

1.14.1 Objectives

The objectives of the study of ergonomics is to optimize the integration of man and machine in

order to increase work rate and accuracy. It involves

1. The design of a work place befitting the needs and requirements of the worker.
2. The design of equipment, machinery and controls in such a manner so as to minimize mental and physical strain on the worker thereby increasing the efficiency, and
3. The design of a conducive environment for executing the task most effectively.

Both work study and Ergonomics are complementary and try to fit the job to the workers; however Ergonomics adequately takes care of factors governing physical and mental strains.

1.14.2 Applications

In practice, ergonomics has been applied to a number of areas as discussed below

1. Working environments
2. The work place, and
3. Other areas.

1. Working environments

(a) The environment aspect includes considerations regarding light, climatic conditions (i.e., temperature, humidity and fresh air circulation), noise, bad odour, smokes, fumes, etc., which affect the health and efficiency of a worker.

(b) Day light should be reinforced with artificial lights, depending upon the nature of work.

(c) The environment should be well-ventilated and comfortable.

(d) Dust and fume collectors should preferably be attached with the equipments giving rise to them.

(e) Glares and reflections coming from glazed and polished surfaces should be avoided.

(f) For better perception, different parts or sub-systems of equipment should be coloured suitably. Colours also add to the sense of pleasure.

(g) Excessive contrast, owing of colour or badly located windows, etc., should be eluded.

(h) Noise, no doubt distracts the attention (thoughts, mind) but if it is slow and continuous, workers become habituated to it. When the noise is high pitched, intermittent or sudden, it is more dangerous and needs to be dampened by isolating the place of noise and through the use of sound absorbing materials.

2. Work place layout

Design considerations

(a) Materials and tools should be available at their predetermined places and close to the worker.

(b) Tools and materials should preferably be located in the order in which they will be used.

(c) The supply of materials or parts, if similar work is to be done by each hand, should be duplicated. That is materials or parts to be assembled by right hand should be kept on right hand side and those to be assembled by the left hand should be kept on left hand side.

(d) Gravity should be employed, wherever possible, to make raw materials reach the operator and to deliver material at its destination (e.g., dropping material through a chute).

(e) Height of the chair and work bench should be arranged in a way that permits comfortable work posture. To ensure this

- Height of the chair should be such that top of the work table is about 50 mm below the elbow level of the operator.

- Height of the table should be such that worker can work in both standing and sitting positions.

- Flat foot rests should be provided for sitting workers.

- Figure 1.12 shows the situation with respect to bench heights and seat heights.

- The height and back of the chair should be adjustable.

- Display panel should be at right angles to the line of sight of the operator.

(f) An instrument with a pointer should be employed for check readings where as for quantitative readings, digital type of instrument should be preferred.

(g) Hand tools should be possible to be picked up with least disturbance or rhythm and symmetry

of movements.

(h) Foot pedals should be used, wherever possible, for clamping declamping and for disposal of finished work.

(i) Handles, levers and foot pedals should be possible to be operated without changing body position.

(j) Work place must be properly illuminated and should be free from glare to avoid eye strain.

(k) Work place should be free from the presence of disagreeable elements like heat, smoke, dust, noise, excess humidity, vibrations etc.

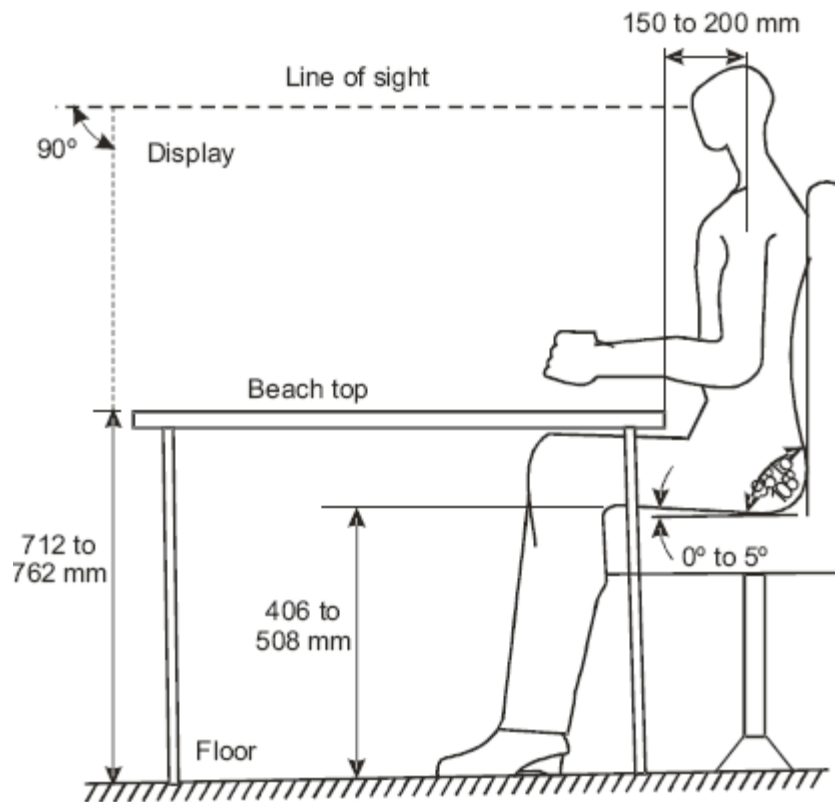

Fig. 1.12: Bench and seat heights

Suggested work place layout

Figure 1.13 shows a work place layout with different areas and typical dimensions. It shows the left hand covering the maximum working area and the right hand covering the normal working area.

Normal working area

It is within the easy reach of the operator.

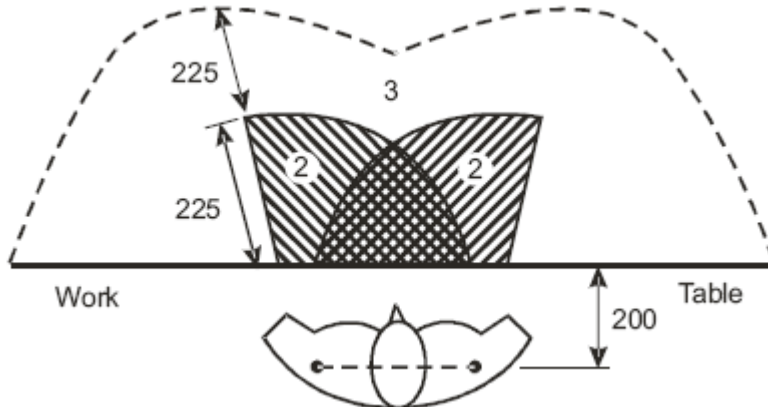

Maximum working area

It is accessible with full arm stretch. Figure 1.14 shows work place layout for assembling small component parts. A-1 is the actual working area and the place of assembly (POA) where four component parts

P-1, P-2, P-3, and P-4 are assembled together. Bins containing P-1, P-2, P-3, and P-4 and commonly

employed tools (CET) (like screw driver, plier, etc.) lie in the normal working area A-2.

ORT

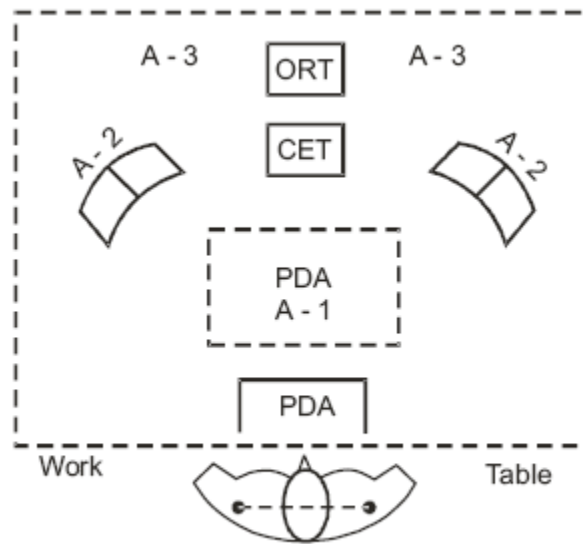

Fig. 1.14: Work place layout for an assembly job

Occasionally required Tools (ORT) (hammers etc.) lie in the maximum working area A-3. After

the assembly has been made at POA, it is dropped into the cut portion in the work table – PDA (Place for dropping assemblies) from where the assembly is delivered at its destination with the help of a conveyer. This work place arrangement satisfies most of the principles of motion economy.

3. Other areas

Other areas include studies related to fatigue, losses caused due to fatigue, rest pauses, amount of energy consumed, shift work and age considerations.

UNIT 2

PROCESS PLANNING

PROCESS PLANNING

- Process planning is a detailed specification which lists the operation, tools, and facilities
- Usually accomplished in manufacturing department
- Also known as operations planning
- Systematic determination of the engineering processes and systems to manufacture a product competitively and economically

DEFINITION

Process planning can be defined as an act of preparing a detailed processing documentation for the manufacture of a piece part or assembly

APPROACHES TO PROCESS PLANNING

1. Manual Process planning
2. Computer Aided Process planning (CAPP)
 - a. Retrieval CAPP system
 - b. Generative CAPP system

MANUAL PROCESS PLANNING

- Manually prepared
- Task involves examining and interpreting engineering drawings, making decisions on machining process selection, equipment selection, operation sequence, and shop practices
- Dependent on judgment and experience of process planner

Advantages

- ✓ Very much suitable for small scale companies
- ✓ Highly flexible
- ✓ Low investment costs

Disadvantages

- ✓ Very complex
- ✓ Time consuming
- ✓ Requires large amount of data
- ✓ Requires skilled process planner
- ✓ More possibilities for human error
- ✓ Increases paper work
- ✓ Inconsistent process plans results in reduced productivity

COMPUTER AIDED PROCESS PLANNING (CAPP)

- To overcome drawbacks of manual process planning Computer Aided Process planning (CAPP) is used
- Provides interface between CAD and CAM

Benefits

- ✓ Process rationalization and standardization
- ✓ Productivity improvement
- ✓ Product cost reduction
- ✓ Elimination of human error
- ✓ Reduction in time
- ✓ Reduced clerical effort and paper work
- ✓ Improved legibility
- ✓ Faster response to engineering changes
- ✓ Incorporation of other application programs

RETRIEVAL CAPP SYSTEM

- It is also called as variant CAPP, widely used in machining applications
- Basic idea behind is, similar parts will have similar process plans
- Process plan for new part is created by recalling, identifying and retrieving an existing plan for a similar part, and making necessary modification for new part

PROCEDURE FOR RETRIEVAL CAPP SYSTEM

- Retrieval CAPP system is based on principles of group technology (GT) and part classification and coding
- For each part family, standard process plan is prepared and stored in computer files
- Through classification and coding, code number is generated

-
- Standard plan is retrieved and edited for new part

Advantages

- ✓ Once a standard plan has been written, variety of parts can be planned
- ✓ Requires simple programming and installation
- ✓ Understandable, and planner has control of final plan
- ✓ Easy to learn and easy to use

Disadvantages

- ✓ Components to be planned are limited to similar components previously planned
- ✓ Requires experienced process planners to modify the standard plan for specific component

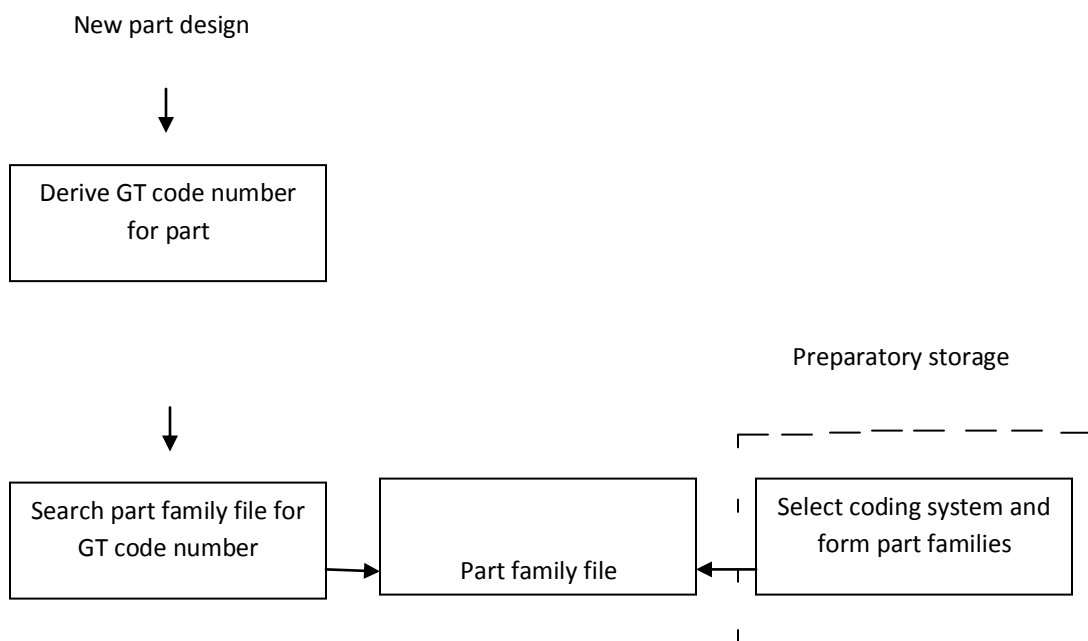

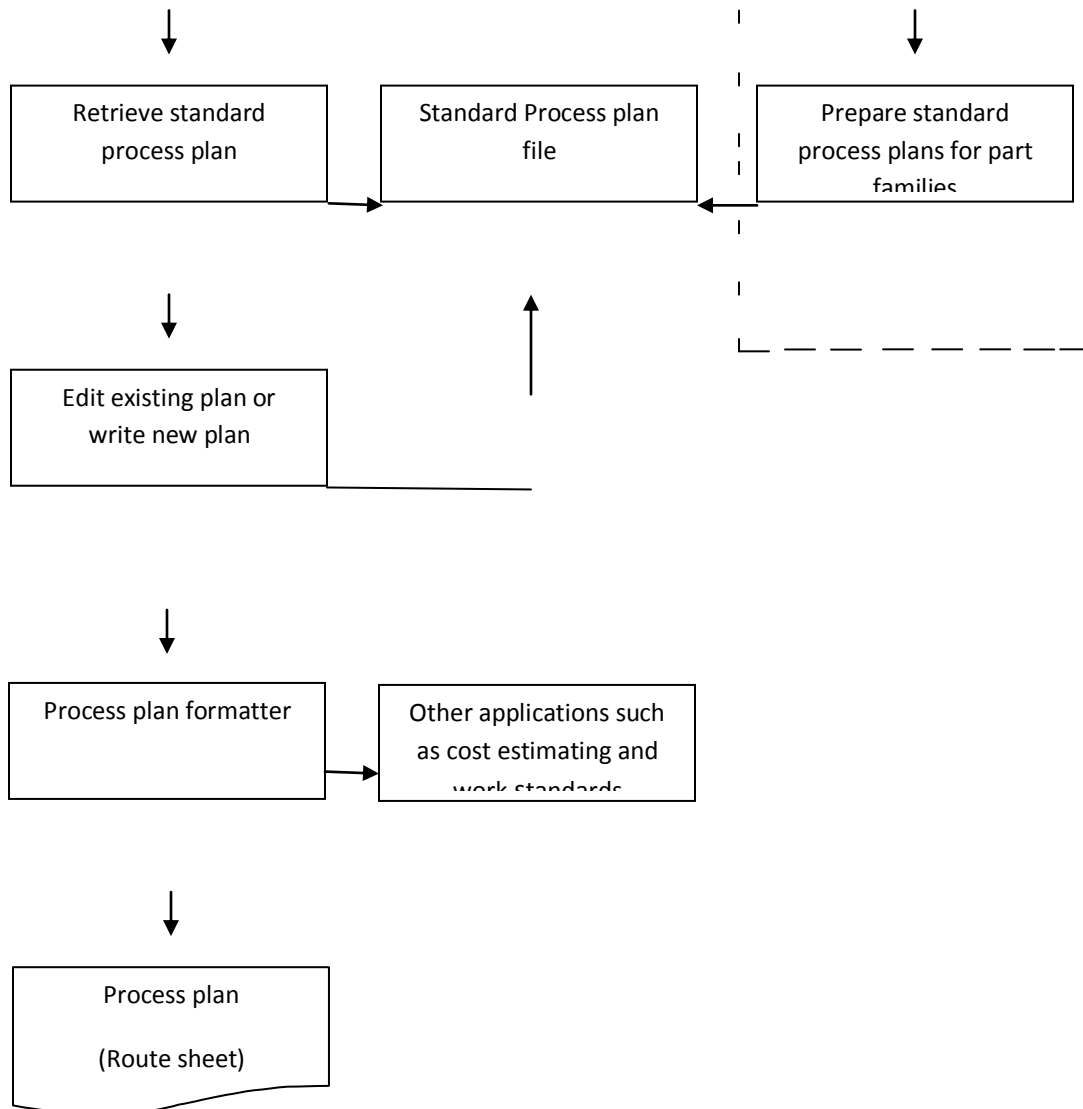

General procedure for using Retrieval CAPP systems

GENERATIVE CAPP SYSTEM

- In this approach computer is used to synthesize or generate each individual process plan automatically without reference to any prior plan
- Generates the process plan based on decision logics and pre-coded algorithms. Computer stores the rules of manufacturing and equipment capabilities

-
- Specific process plan for specific part can be generated without any involvement of process planner

Components of Generative CAPP system

- ❖ Part descriptor
- ❖ Subsystem to identify machine parameters
- ❖ Subsystem to select and sequence individual operations
- ❖ Database
- ❖ Report generator

Advantages

- ✓ Generate consistent process plan rapidly
- ✓ New components can be planned as easily as existing components
- ✓ It has potential for integrating with automated manufacturing facility to provide detailed control information

Drawbacks

- ✓ Complex and very difficult to develop

PROCESS PLANNING ACTIVITIES

1. Specific activities involved in Process planning are
2. Analysis of the finished part requirements as specified in the engineering design
3. Determining the sequence of operation required
4. Selecting the proper equipment to accomplish the required operations
5. Calculating the specific operation setup times and cycle times on each machine
6. Documenting the established process plans
7. Communicating the manufacturing knowledge to the shop floor

1. Analyze finished part requirements

- Component drawing should be analyzed to identify its features, dimensions, and tolerance specifications
- Part's requirement defined by its features, dimensions, and tolerance specifications will determine corresponding processing requirements

2. Determine operating sequence

- Basic aim is to determine the type of processing operation that has the capability to generate various types of features, given the tolerance requirements

-
- There are two ways of viewing decision process
 - ✓ First view is to consider processing evaluation of part from rough state to finished final state. In this view material is removed or modified on rough part in stages in order to transform it into finished part
 - ✓ Second view is to consider part evaluation from finished state back to rough/ initial state. In this view material is added back onto the part.

3. Select machines

- Machine selection requires determining how the part would be processed on each of the alternative machines so that best machine can be selected
- At this phase, firm has to decide whether to make or buy the component part
- Break even analysis is most convenient method for selecting optimum method of manufacture or machine amongst the competing ones

- Factors which influence the selection of machine are,
 - ❖ Economic considerations
 - ❖ Production rate and unit cost of production
 - ❖ Durability and dependability
 - ❖ Lower process rejection
 - ❖ Minimum set-up and put away times
 - ❖ Longer productive life of machines or equipment
 - ❖ Functional versatility

4. Material selection parameters

- Function
- Appearance
- Reliability
- Service life
- Environment
- Compatibility
- Productivity
- Cost

5. Calculate processing time

- Determination of set-up times requires knowledge of available tooling and sequence of steps necessary to prepare the machine for processing given work piece
- For establishing accurate set-up times, detailed knowledge of equipment capacity, tooling, and shop practice required
- Calculation of part processing time requires determination of sequence of processing steps on each machine. This is called as OUTPLANNING

-
- After calculation of processing time, appropriate times for loading, part unloading, machine indexing, and other factors involved in one complete cycle for processing a part must be included to compute the expected machine cycle time
 - Allowances are added with machine cycle time to calculate standard cycle time for processing one piece
 - Appropriate machine rates are added with calculated cycle time to calculate expected standard cost for given operation

6. Document process planning

- Process plan is documented as job routing or operation sheet
- Operation sheet also called “route sheet”, “instruction sheet”, “traveler”, “planner”

- Information provided by route sheet are,
 - ✓ Part identification
 - ✓ Description of processing steps in each operation
 - ✓ Operation sequence and machines
 - ✓ Standard set-up and cycle times
 - ✓ Tooling requirements for each operation
 - ✓ Production control information showing the planning lead time at each operation

Reasons for documentation

- To have a record on how a part is processed in order to plan future parts with similar design requirements in a consistent manner
- To provide a record for future job quoting, cost estimating, and standard costing systems
- To act as a vehicle for communication

7. Communicate process knowledge

- Communication is essential to ensure that part will be processed according to most economical way
- Process documentation and communication provide basis for improved part consistency and quality in manufacturing

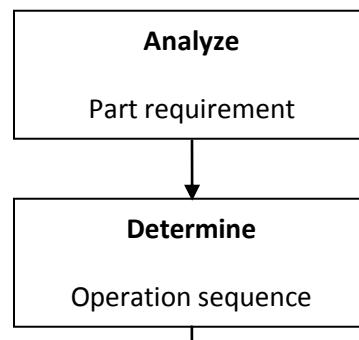



Process planning activities

DEVELOPING MANUFACTURING LOGIC AND KNOWLEDGE

- To support process planning system, the acquisition and documentation of manufacturing knowledge is very essential
- Knowledge structure should be determined prior to any type of program coding or data presentation
- Knowledge structure will help to ensure error reduction, debugging ease, clarity, and future modification
- Production engineers need a tool to develop Knowledge structure format that can be used in an interactive process and will emphasize what questions to ask and what data to collect to support standardized format
- Commonly used tools are,
 1. Flow charts
 2. Decision tables
 3. Expert system shells

1. FLOW CHARTS

Most commonly used tool for collection and display of manufacturing knowledge

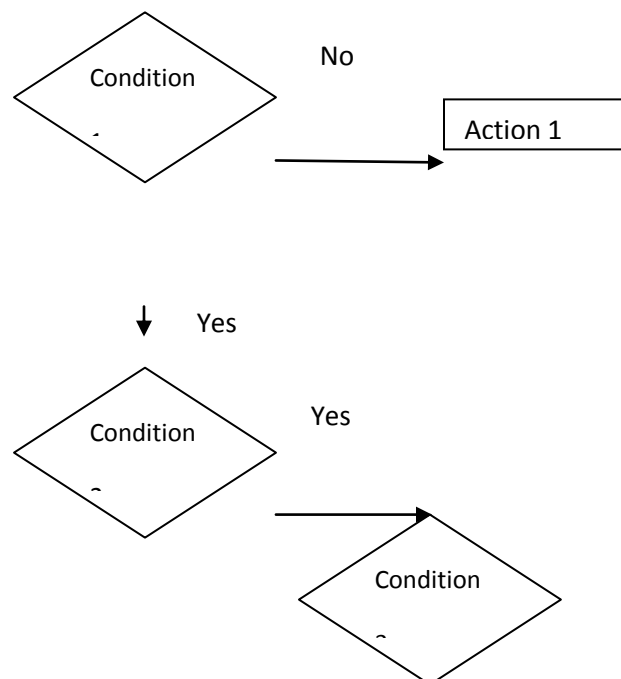

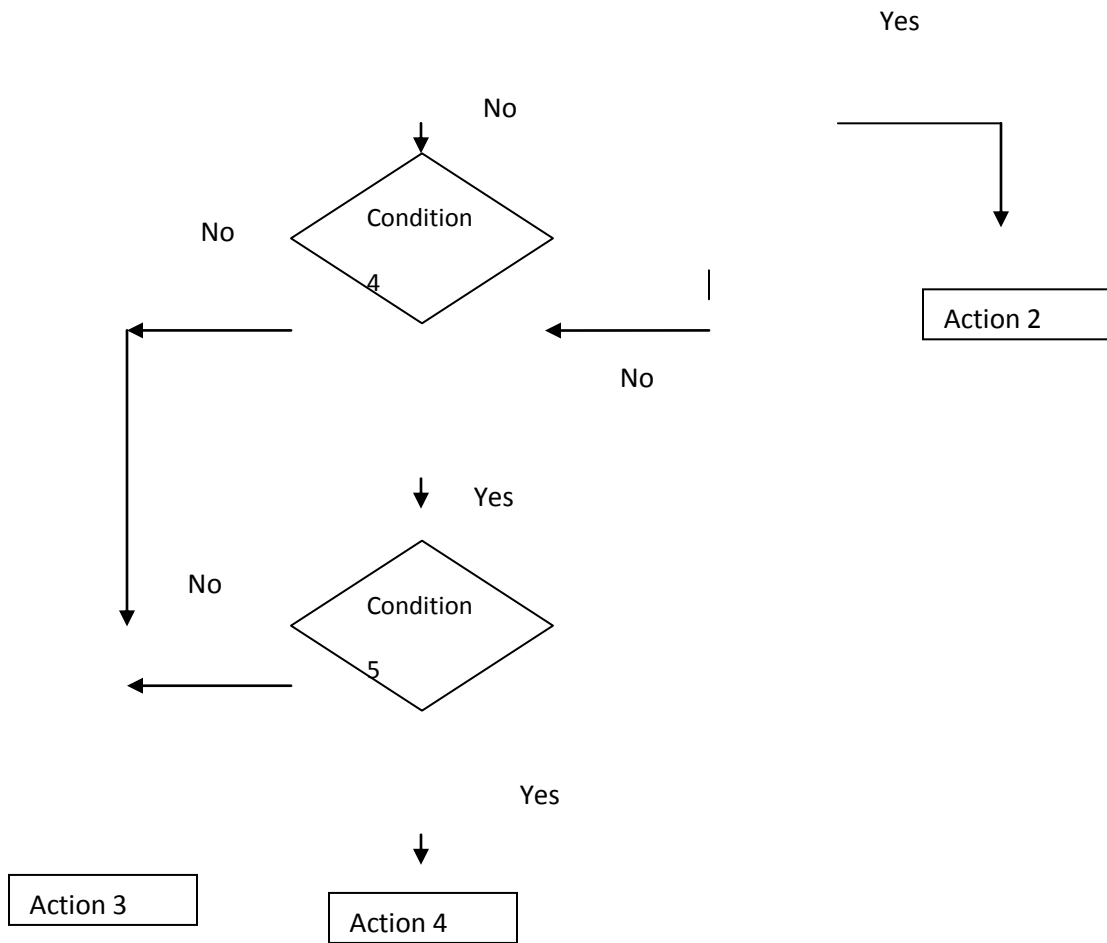

Flow chart format

Disadvantages of flow charts

- It focus on process rather than on the structure decision logic
- Provides no check against incompleteness, and redundancy

2. DECISION TABLE

It is a system / logic tool to bring together, analyze, and display complex decision logic in such a way that its meaning can be easily grasped

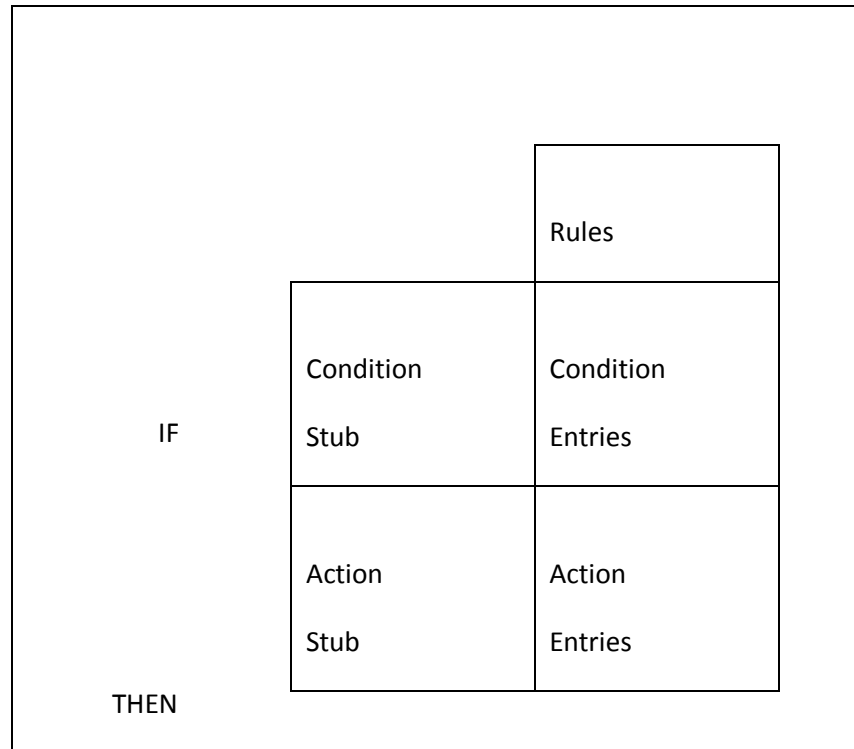

Decision table format

- IF portion of table shows various condition that may apply
- THEN portion of table indicates appropriate available actions
- Left portion of table contains stub in which each of the conditions or actions is stated
- Right portion lists various entries that are possible for each of the stub conditions and actions

Benefits

- ✓ It assists the production engineers in thinking through a problem thoroughly and presenting its resolution in a systematic and rationally structured format
- ✓ Ensure accuracy, eliminate redundancy, and avoid contradiction
- ✓ It assists in stating problem, agreeing on criteria, stating alternatives, and accepting actions between criteria and alternatives
- ✓ Provide knowledge structure and readable documentation as by-product

3. EXPERT SYSTEM SHELLS

Using this tool, knowledge engineers can collect information to develop knowledge base within predefined decision structure of shell

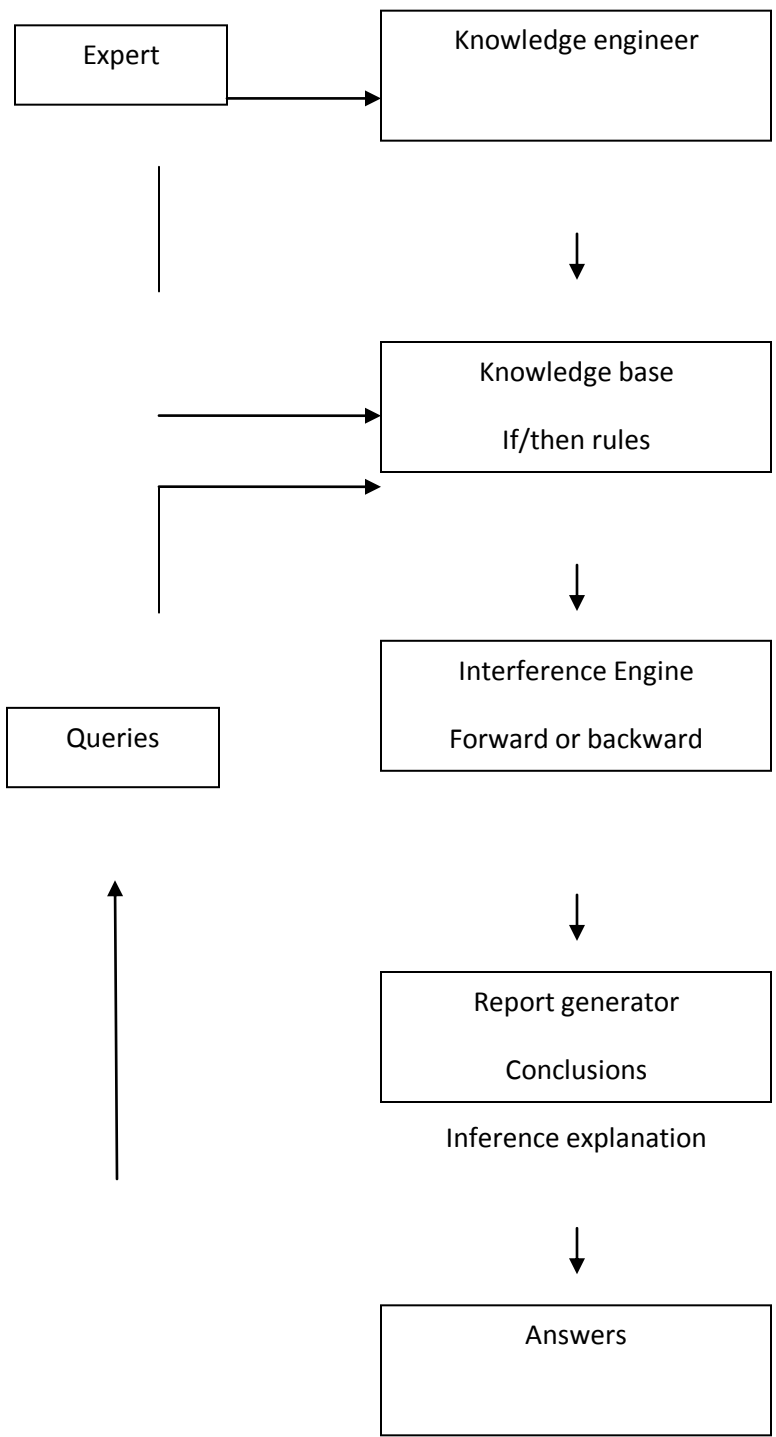



Expert system shells format

- Expert system shells format is similar to decision table format
- Like decision table format, knowledge base is formatted in structures of “if this condition then this action”, or “if this condition then this action, or else this action”

SELECTION OF PROCESS PLANNING SYSTEM

Factors to be considered while selecting best process planning system are,

- Environment in which process planning is conducted
- Organizational structure of company
- Technical expertise available to the company
- Needs and objective of company regarding generation of manufacturing information and process plans

2 MARKS

1. Define Process planning

Process planning can be defined as an act of preparing a detailed processing documentation for the manufacture of a piece part or assembly.

2. Brief about scope of Process planning

- Process rationalization and standardization
- Faster response to engineering changes
- Standard plans leads to achieve six sigma level

3. What are the documents used in Process planning?

- Process sheet
- Operation sheet
- Route sheet

4. What are the factors affect process planning?

- Volume of production
- The skill and experience of manpower
- Delivery dates for parts or products
- Material specifications
- Accuracy and process capability of machines
- Accuracy requirements of parts or products

5. What are the reasons for process documentation?

- To have a record on hoe a part is processed in order to plan future parts with similar design requirements in a consistent manner
- To provide a record for future job quoting, cost estimating, and standard costing systems
- To act as a vehicle for communication

6. State the general approaches to process planning?

1. Manual Process planning

2. Computer Aided Process planning (CAPP)

- a. Retrieval CAPP system
- b. Generative CAPP system

7. What are the tools used
for acquiring and
documenting
knowledge?

8. State the benefits of decision table?

- ✓ It assists the production engineers in thinking through a problem thoroughly and presenting its resolution in a systematic and rationally structured format
- ✓ Ensure accuracy, eliminate redundancy, and avoid contradiction
- ✓ It assists in stating problem, agreeing on criteria, stating alternatives, and accepting actions between criteria and alternatives
- ✓ Provide knowledge structure and readable documentation as by-product

9. List Material selection parameters

- Function
- Appearance
- Reliability
- Service life
- Environment
- Compatibility
- Productivity
- Cost

10. State the process planning activities

1. Specific activities involved in Process planning are
2. Analysis of the finished part requirements as specified in the engineering design
3. Determining the sequence of operation required
4. Selecting the proper equipment to accomplish the required operations
5. Calculating the specific operation setup times and cycle times on each machine
6. Documenting the established process plans
7. Communicating the manufacturing knowledge to the shop floor

UNIT 3

INTRODUCTION TO COST ESTIMATION

3.0 INTRODUCTION

Cost estimation may be defined as the process of forecasting the expenses that must be incurred to manufacture a product.

These expenses take into consideration all expenditures involved in design and manufacturing with all the related service facilities such as pattern making, tool making as well as portion of the general administrative and selling costs. Cost estimates are the joint product of the engineer and the cost accountant.

Estimating is the calculation of the costs which are expected to be incurred in manufacturing a component in advance before the component is actually manufactured.

Costing may be defined as a system of accounts which systematically and accurately records every expenditure in order to determine the cost of a product after knowing the different expenses incurred in various department.

3.1 REASONS FOR DOING ESTIMATES

Cost estimates are developed for a variety of different reasons. The most important reasons are shown below.

Should the product be produced? When a company designs a new product, a detailed estimate of cost is developed to assist management in making an intelligent decision about producing the product.

This detailed estimate of cost includes an estimate of material cost, labour cost, purchased components and assembly cost. In addition to product cost, many other elements must be estimated. These include all tooling costs.

A cost estimate must be developed for jigs, fixtures, tools, dies and gauges. Also, the cost of any capital equipment must be entered into the estimate. These figures are usually supplied through quotation by vendors.

An estimate of this nature will include a vast amount of details, because if management approves the project, the estimate now becomes the budget.

Estimates as temporary work standards. Many companies that produce product in high volume, such as automotive companies, will use estimates on the shop floor as temporary work standards.

Temporary work standards are replaced with time studied work standards as rapidly as possible.

3.1.1 Importance of Estimating

Estimating is of great importance to a concern because it enables the factory owner to decide about the manufacturing and selling policies.

It is obvious that too high estimates will not get jobs to the firm by quoting higher rates according to over estimate whereas under estimating will put the owner to a loss and will lead the concern to utter failure.

So, estimation should be carried out accurately. The persons preparing estimates should be highly qualified and experienced. They should be chosen from shops or should be first trained in all the shop methods and their estimates preparation.

3.2 OBJECTIVES OR PURPOSE OF ESTIMATING

The main purpose or objective of estimating are

- (i) To establish the selling price of a product.
- (ii) To ascertain whether a proposed product can be manufactured and marketed profitably.
- (iii) To determine how much must be invested in equipment.
- (iv) To find whether parts or assemblies can be more cheaply fabricated or purchased from outside (make or buy decision).
- (v) To determine the most economical process, tooling or material for making a product.
- (vi) To establish a standard of performance at the start of project.
- (vii) For feasibility studies on possible new products.
- (viii) To assist in long term financial planning.
- (ix) To prepare production budget.
- (x) To help in responding to tender enquiries.
- (xi) To evaluate alternate designs of a product.
- (xii) To set a standard estimate of costs.
- (xiii) To initiate programs of cost reduction that result in economics due to the use of new materials, which produce lower scrap losses and which create savings due to revisions in methods of tooling and processing, and
- (xiv) To control actual operating costs by incorporating these estimates into the general plan of cost accounting.

3.3 FUNCTIONS OF ESTIMATING

- (i) To calculate the cost of new material needed to manufacture a product.
- (ii) To find the cost of parts to be purchased from outside vendors.
- (iii) To find the cost of equipment, machinery, tools, jigs and fixtures etc. required to be purchased to make the product.
- (iv) To calculate the direct and indirect labour cost associated with the manufacture of the product, based upon work study.
- (v) To calculate various overhead charges associated with the product.
- (vi) To decide about the profit to be charged, taking into consideration other manufacturers of same product in the market.
- (vii) To calculate the selling price of the product.
- (viii) To maintain records of previous estimating activities of the company for future references.
- (ix) To decide the most economical method of making the product.
- (x) To submit cost estimates with the competent authority for further action.

3.4 COST ACCOUNTING OF COSTING

It is the determination of an actual cost of a component after adding different expenses incurred in various departments or it may be defined as a system which systematically records all the expenditures to determine the cost of manufactured products.

The work of cost accountings begins with the pre-planning stage of the product. It ends only after the whole lot of the product has been fully manufactured. Costing progresses with the progress of the product through the plant.

3.5 IMPORTANCE OF COSTING

Costing is an essential work for the efficient management of any enterprise and gives most useful information for the preparation of financial accounts.

It enables a business not only to find out what various jobs or processes have costed but also what they should have costed.

It indicates where losses are wastage are occurring before the work is finished, so that immediate action may be taken to avoid such loss or waste. Also all expenditure are localized and thereby controlled in the light of information provided by the cost records.

Costing shows which type of output will yield a profit and which type does not. Thus, it makes up the deficiency.

A planned system of cost accounting will point out the weak spots and thus enable the administration to have a clear picture and show up immediately the essential facts in such a way that the responsible persons can put forth their efforts to bring improvements and reduce costs.

Costing has proved so beneficial that nowadays almost every concern has adopted the cost accounting system.

3.6 AIMS OF COST ACCOUNTING

The purpose of costing are:

1. To compare the actual cost with the estimated cost to know whether the estimate had been realistic or not.
2. Wastages and undesirable expenses are pointed out requiring corrective measures.
3. The costing data helps in changing the selling price because of change in material cost of labour cost etc.
4. It helps to locate the reasons for the increase or decrease of loss of profits of a company.
5. It helps in determining the discount on catalogue or market price of the product.
6. The actual cost helps the company to decide whether to continue with the manufacture of a product or to buy it from outside.
7. It helps the enterprise to prepare its budget.
8. The costing data helps to formulate policies and plans for the pricing of a new job.
9. It helps in regulating from time to time the production of a job so that it may be profitable to the company.

3.7 METHODS OF COSTING

- (a) Process costing.
- (b) Job costing.
- (c) Batch costing.
- (d) Hybrid costing systems.

(a) Process costing

Process cost sheet							
Accounting Period.....							
Date Ref. Mat. Labour Over/head Cost-Center-1				Cost Center-2			
	(OH)	Mat.	Labour	O.H.	Mat.	Labour	O.H.

Summary:

Center-1	Rs.	Rs.	Production
Materials	XXX		No.of Units _____
Labour	XXX	—	Cost per unit. Rs. _____
Overhead	XXX	XXX	
Center-2			
Materials	XXX		
Labour	XXX		
Overhead	XXX	XXX	
		Rs. XXX	

- This method is employed when a standard product is being made which involves a number of distinct processes performed in a definite sequence.

Introduction to Cost Estimation 83

- In oil refining, chemical manufacture, paper making, flour milling, and cement manufacturing etc., this method is used.

- The object i.e., record and trace costs for each distinct stage.

- While costing, the by-products of each process should be considered.

- This method indicates the cost of a product at different stages as it passes through various processes.

- The total time spent and materials used on each process, as well as services such as power, light and heating are all charged. For this purpose cost sheet may be employed.

The process cost sheet is a summary of all operations for the month. The current operating charges are entered on the sheet showing

1. The transfer cost from the previous operation.

2. The costs incurred by each operation showing materials, labour and overhead in separate columns.

This separation of transfer cost and conversion cost is extremely important for the charges incurred by a department are its measures of efficiency.

The sheet can be used as a basis for:

1. Closing entries at the end of each month.

2. Operating statements, without need to lookup the ledger accounts.

Within the cost ledger an account is kept for each process. The direct material, direct labour and factory overhead costs are transferred from the process cost sheet. There are debited to the process account, and then any completed units are credited to cover the transfer to the next process. The balance on the account represents the work-in-progress at the end of the period, which, of course, becomes the opening balance for the next period.

(b) Job costing or order costing

- Job costing is concerned with finding the cost of each individual job or contract. Examples are to be found in general (job order) engineering industries, ship building, building contracts, etc.
- The main features of the system is that each job has to be planned and costed separately.
- Overhead costs may be absorbed on jobs on the basis of actual costs incurred or on predetermined costs.
- The process of determining in advance what a job or order will cost is known as estimating.

It involves consideration of the following factors for each job/order:

1. Materials requirements and prices to arrive at the direct material cost.
2. Labour hours and rates to determine labour costs.
3. Overhead costs.
4. Percentage added to total cost to cover profit.

A record of above costs per unit time is kept in separate cost sheets.

(c) Batch costing

- Batch costing is a form of job costing. Instead of costing each component separately, each batch of components are taken together and treated as a job. Thus, for example, if 100 units of a component, say a reflector are to be manufactured, then the costing would be as far a single job. The unit price would be ascertained by dividing the cost by 100.
- Besides maintaining job cost sheets it may also be necessary to keep summary sheets on which the cost of each component can be transferred and the cost of the finished product can be calculated. This applies in general engineering where many hundreds of components may go towards making the finished machine or other product.

(d) Hybrid costing systems

- Many costing systems do not fall nearly into the category of either job costing or process costing. Often systems use some features of both main costing systems.
- Many engineering companies use batch costing, which treats each batch of components as a job and then finds the average cost of a single unit.
- Another variation is multiple costing, used when many different finished products are made. Many components are made which are subsequently assembled into the completed article, which may be bicycles, cars, etc. Costs have to be ascertained for operations, processes, units and jobs, building together until the total cost is found.
- Different names may be used to describe either process costing or job costing. Thus, for example, unit costing is the name given to one system where there is a natural unit, such as sack of flour, a barrel of beer etc.
- In unit costing method, the expenses on various items are charged per unit quantity or production.
- Operation costing is a variation of unit costing, and is used when production is carried out on a large scale, popularly known as mass production.
- Operation costing is the term applied to describe the system used to find the cost of performing a utility service such as transport, gas, water or electricity.
- In this method, the cost per unit is found on the basis of operating expenses incurred on various items of expenditure.
- Unit costing, operation costing and operating costing are variations of process costing.
- Contract or terminal costing is the name given to job costing employed by builders and constructional engineers.
- All these methods ascertain the actual cost.

Departmental costing method

In big industries like steel industry or automobile industry each department is producing independently one or more components. Departmental costing method is used in such industries and the actual expenditure of each department on various products is entered on the separate cost sheet and the costing for each department is separately undertaken.

3.8 DIFFERENCE BETWEEN COST ESTIMATING AND COST ACCOUNTING

<i>Point of comparison</i>	<i>Cost estimating</i>	<i>Cost accounting</i>
1. Type of cost	It gives an expected cost of the product based on the calculations by means of standard formulae or certain established rules.	It gives actual cost of the product based on the data collected from the different expenditures actually done for a product.
2. Duration of process	It is generally carried out before actual production of a product. Due to certain unforeseen or unexpected expenses coming to light at a later stage, estimate may be modified or revised.	It usually starts with the issue of order for production of a product and ends after the product is dispatched for sale. For sale commitments like free repair or replacement, the process continues upto the expiry period of guarantee or warranty because the overhead expenses incurred in the above case will be included in the production cost.
3. Nature of quality	A qualified technical person or engineer having a thorough knowledge of the drawings and manufacturing process is required. Thus, it is a technical work, instead of a clerical one.	It can be done by a person qualified for accounts instead of a technical person. The cost accountant develops his knowledge of technical person. The cost accountant develops his knowledge of technical terms and process while working. Thus, this work instead of being of technical nature is more of a clerical nature.
4. Main objectives	<ul style="list-style-type: none">(i) To set standard for, with actual cost.(ii) To help in setting up market price for a proposed product to be manufactured.(iii) To decide whether it is economical to buy or manufacture a product under prevailing market conditions.(iv) To facilitate in filling up of tenders or quotation of products for supply. After receipt of supply order from the buyers the production will be started.	<ul style="list-style-type: none">(i) To help in comparison of cost with estimates to know if they are over, under realistic as well as to know where the actual costs involve unnecessary wastage of men, materials, machines and money.(ii) To facilitate the budget preparation as well as to provide cost data for future estimates of new products of their pricing plans.(iii) To facilitate in deciding output targets time to time.(iv) To facilitate in meeting certain legal obligations or regulations.

3.9 DIFFERENCE BETWEEN FINANCIAL ACCOUNTING AND COST ACCOUNTING

- Accounting information is vital for showing the indebtedness of a business accounting uses words and figures to communicate the transactions which have been entered into.
- Both financial accounting and cost accounting are concerned with the recording of transactions so as to enable to calculate profit (or loss) for one or more transactions and to show the assets and liabilities owned or incurred by the business.
- Financial accounting is concerned with the external transactions and, therefore, record all dealings with the outside world. Any purchase or sale of goods and services and fixed assets, whether for cash or on credit are covered.
- Cost accounting, on the other hand, deals with the internal affairs of a business. It attempts to show the results of the operations carried out and emphasizes throughout the measurement and achievement of efficiency.
- Fixed assets, workers and materials are brought together with the object of transforming the resources employed and thereby obtaining a saleable product or service.
- Generally special attention is paid to the control aspect of the quantities and prices of the resources necessary for the transformation.

3.10 ELEMENTS OF COST INTRODUCTION

The total cost is made up of three main elements (figure 3.1).

1. Material.
2. Labour.
3. Expenses.

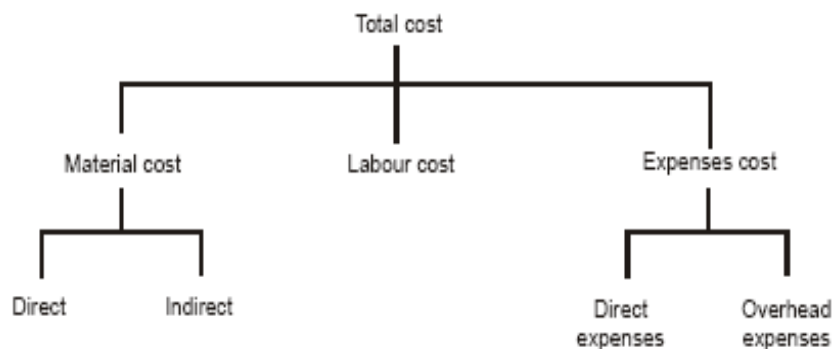

Fig. 3.1

3.11 MATERIAL COST

Material cost consists of the cost of materials which are used in the manufacture of product. It is divided into the following:

3.11.1 Direct Material Cost

It is the cost of those materials which are directly used for the manufacture of the product and become a part of the finished product.

The procedure for calculating the direct material cost is as follows:

- (i) From the product drawing, make a list of all the components required to make the final product.
- (ii) Calculate the volume of each component from the drawing dimensions after adding

machining allowances, wherever necessary.

(iii) The volume of component multiplied by the density of material used gives the weight of the material per component.

(iv) Add process rejection and other allowances like cutting allowance to get the gross weight per component.

(v) Multiply the gross weight by the rate of material per unit weight to get the cost of raw material per component.

(vi) The cost of raw material for all the components is, similarly, calculated and added up which gives the cost of direct material for the product.

3.11.2 Indirect Material Cost

In addition to direct materials a number of other materials are necessary to help in the conversion of direct materials into final shape. Though these materials are consumed in the production, they don't become part of the finished product and their cost cannot be directly booked to the manufacture of a specific product. Such materials are called indirect materials.

The indirect materials include oils, general tools, greases, sand papers, coolants, cotton waste etc. The cost associated with indirect materials is called indirect material cost.

Depending upon the product manufactured, the same may be direct materials for one concern and indirect materials for others.

3.12 LABOUR COST

It is the expenditure made on the salaries, wages, overtime, bonuses, etc. of the employees of the enterprise. It can be classified as

3.12.1 Direct Labour Cost

Direct labourer is one who actually works and processes the materials to convert it into the final shape. The cost associated with direct labour is called direct labour cost.

The direct labour cost can be identified and allocated to the manufacture of a specific product. Examples of the direct labour are the workers operating lathes, milling machines or welders, or assemblers in assembly shop. The direct labour cost may be allocated to a product or job on the basis of time spent by a worker on a job.

3.12.2 Determination of Direct Labour Cost

Determination of labour is much more complicated problem than calculating material cost. To find the labour cost one must have the knowledge of all the operations which are carried out for production of the product, tools and machines to be used and the departments in which the product is to be manufactured.

For calculating time required for a particular job following considerations should be taken into account:

- (a) Setup time.
- (b) Operation time.
 - (i) Handling time.
 - (ii) Machining time.
- (c) Tear down time
- (d) Down (or) lost time.
- (e) Miscellaneous allowances:
 - (i) Personal allowance.
 - (ii) Fatigue allowance.
 - (iii) Tool sharpening and changing allowance.
 - (iv) Checking allowance.

- (v) Other oiling and cleaning.
- (vi) Filling coolant reservoirs.
- (vii) Disposing of scraps and surplus stocks.

Setup time

Before starting any operation, first we have to set the job, tools and other auxiliary equipment. So, set up time is the time required for setting and fixing the jobs and tools on the machine.

Time to study the drawings, blueprints, time to make adjustment for getting the required size are all included in set up time. This time is also known as setting time.

Man (or) handling time

This is the time the operator spends loading and unloading the work, manipulating the tools and the machine and making measurements during each cycle of operation.

Machinery time

This is the time during each cycle of operation that the machine is working or the tools are cutting.

Example

Let us take the example of a drill press operation which has the following sequence of elements of handling and machining

Pick up part	
Place the jig	
Fit in the jig	Handling time
Position under drill	
Advance drill to work	
Drill hole through part	Machining time
Clear the drill from the work	
Move jig into clear position	
Release part from jig	Handling time
Remove part from jig	

Tear down time

Tear down time is the time required to remove the tools from the machine and to clean the tools and the machine after the last component of the batch has been machined. This time is usually small.

It will seldom run over 10 minutes on the average machine in the shop. It may require only a few minutes to tear down a set up on a drilling press and 10 to 15 minutes on the turret lathe. In exceptional case, it may go up to as high as 30 minutes on very large boring mills and large milling machines.

Down (or) lost time

This is the unavoidable time lost by the operator due to breakdowns, waiting for the tools and materials etc.

Miscellaneous allowances (allowances in estimation)

A worker cannot work for 8 hours continuously without rest. Also efficiency decreases as the time passes due to fatigue etc. He also requires for tool sharpening, checking measurements and personal calls. All these allowances come under this category. These allowances generally consumes 15 to 20% of total time.

(a) Personal allowances

This is the time allowed for a worker for his personal needs like going to rest rooms, smoking, having a cup of tea, going to Lavatories to take water for personal cleanliness etc. This is generally about 5% of the total working time.

(b) Fatigue

The efficiency of the worker decreases due to fatigue (or) working at a stretch and also due to working conditions such as poor lighting, heating (or) ventilation. The efficiency is also affected by the psychology of the worker. It may be due to domestic worries, job securities etc. For normal work, the allowance for fatigue is about 5% of the total time. This allowance can be increased depending upon the type and nature of work and working conditions.

(c) Total sharpening and changing allowance

It is the time required to remove the tool and its holder, to walk up to the grinder to grind the tools, to come back to the machine and then to fix the tool again in the machine.

(d) Checking allowance

It is the time taken for checking the dimensions. Rough dimensions take less while accurate dimensions require more time. This allowance should be considered only when the operator is doing checking only and no work on the machine. If the checking is done during machining time it should not be considered. The checking times for the various instruments are given below to check one dimension.

With rule	0.10	minute
Vernier caliper	0.50	minute
Inside caliper	0.10	minute
Outside caliper	0.05	minute
Inside micrometer	0.30	minute
Outer micrometer	0.15	minute
Depth micrometer	0.20	minute
Dial micrometer	0.30	minute
Thread micrometer	0.25	minute
Plug gauge	0.20	minute
Snap gauge	0.10	minute

(e) Oiling and cleaning

It is the time required for cleaning the machine and to lubricate its various parts for smooth functioning of the machine.

(f) Filling coolant reservoirs

It is the time required for filling the reservoirs of the coolant which are used for cooling the jobs and tools.

(g) Disposing off scraps and surplus stocks

It is the time consumed for disposing off the scraps and other surplus stocks. The miscellaneous allowances should be added to the set up, the operation and tear down times to complete the element.

3.12.3 Indirect Labour Cost

Indirect labourer is one who is not directly employed in the manufacturing of the product but his services are used in some indirect manner.

The indirect labour includes supervisors, foreman, storekeeper, gatekeeper, maintenance, staff, crane driver etc. The cost associated with indirect labour is called indirect labour cost.

The indirect labour costs cannot be identified with a particular job or product but are charged on the total number of products made during a particular period in a plant.

3.13 EXPENSES

Apart from material and labour cost in each factory there are several other expenditures such as cost of special layouts, designs, etc. hire of special tools and equipments; depreciation charges of plants and factory building; building rent; cost of transportation, salaries and commissions to salesman etc.

All these expenditures are known as overheads or expenses. So, from above it is clear that

3.13.1 Direct Expenses

Direct expenses also known as chargeable expenses include any expenditure other than direct material or direct labour incurred on a specific cost unit. These are the expenses which can be charged directly to a particular job and are done for that specific job only. For example, hire of special tools and equipment, cost of special jigs and fixtures or some special patterns and its maintenance cost,

costs of layouts, designs and drawings or experimental work on a particular job etc.

3.13.2 Indirect Expenses (Overheads)

These are known as overhead charges, burden or on cost. All the expenses over and above prime cost are indirect expenses. Overhead is the sum of indirect labour cost, indirect material cost and other expenses including service which cannot be conveniently charged to specific cost unit. These can be further classified as

1. Production expenses/Factory expenses.
2. Administrative expenses.
3. Selling expenses.
4. Distribution expenses.

(i) Production expenses

These expenses cover all indirect expenditures incurred by the undertaking from the receipt of the order until its completion ready for dispatch. Production expenses are also known as factory on cost, production overhead, factory overhead, work on cost, works overhead etc. Some examples of factory expenses or production expenses are:

- (i) Rent, rates and insurance chargeable against the works.
- (ii) Indirect labour example: supervision such as salaries of foreman, supervisors, factory manager etc.
- (iii) Consumable stores and all forms of indirect material such as cotton waste, grease, oil etc.
- (iv) Depreciation, maintenance and repair of buildings, plant, machine tools etc.,
- (v) Power such as steam, gas, electricity, hydraulic or compressed air, internal transport etc.

(ii) Administrative expenses

These expenses include all the expenses on managerial or administrative staff for the planning and policy making work. Some examples of administrative expenses are:

- (i) Salaries of directors and managing directors.
- (ii) Salaries of cost, finance and secretary office staff including clerks and peons.
- (iii) Expenses of direct amenities like telephone, coolers and other modern equipments.
- (iv) Travelling expenses for attending meetings etc.
- (v) Charges for electric consumption for light, heating and cooling.

(vi) Stationary, auditing expenses.

(vii) Insurance of building and employees, repairs, maintenance and depreciation of building and furniture.

(iii) Selling expenses

These consist of the expenditures spent towards securing orders, and finding or retaining markets for the products manufactured. Following is the list of selling expenses:

(i) Advertising and publicity expenses.

(ii) Salaries of the sales department staff including sales manager, salesman etc.

(iii) Travelling expenses of sales engineers.

(iv) Cost of preparing tenders and estimates.

(v) Expenses of making blocks and posters.

(vi) Sales stock storage charges.

(iv) Distribution expenses

These are the expenses which are paid for the distribution of the product. It includes the expenditure made on holding finished stock, packing cost and dispatching them to the customer.

This type of expenses include

(i) Finished stock storages.

(ii) Lost of packing.

(iii) Loading, unloading charges, freight and warfare.

(iv) Expenses of transportation and vehicles.

(v) Salaries of dispatch clerks and labourers.

3.14 COST OF PRODUCT (LADDER OF COST)

The elements of cost can be combined to give following types of cost:

1. Prime cost: It consists of direct material cost, direct labour cost and direct expenses.

Prime cost = Direct material cost + Direct labour cost + Direct expenses.

Prime cost is also called as direct cost.

2. Factory cost: It consists of prime cost and factory expenses.

Factory cost = prime cost + factory expenses.

Factory cost is also named as works cost.

3. Office cost: It consists of factory cost and administrative expenses.

Office cost = Factory cost + Administrative expenses

It is also named as manufacturing cost (or) cost of production.

4. Total cost: It includes manufacturing cost and selling and distribution expenses.

Total cost = Manufacturing cost + selling and distribution expenses.

Selling price

If the profit is added in the total cost of the product, it is called selling price. The customers get the

articles by paying the price which is named as selling price.

Selling price = Total cost + Profit

= Total cost – Loss

Making price (or) catalogue price: Some percentage of discount allowed to the distributors of product is added into the selling price. The result obtained is called the market price (or) catalogue price (figure 3.2).

				Profit (or) Loss	
			Selling + Distribution expenses		
		Administrative expenses	Office cost (or) production	Total (or) selling cost	Selling price (or) Market price
	Factory expenses	Factory cost (or)	(or) Manufacturing cost	(or)	Catalogue price
Direct material	Prime cost (or)	Works cost	(or)		
Direct labour	Direct cost				
Direct expense					

Fig. 3.2: Ladder of cost

UNIT 4

COST ESTIMATION

4.1 TYPES OF ESTIMATE

Estimates can be developed in a variety of different ways depending upon the use of the estimates and the amount of detail provided to the estimator.

Every estimator should understand every estimating method and when to apply each, because no one estimating method will solve all estimating problems.

4.1.1 Guesstimates

Guesstimates is a slang term used to describe an estimate that lacks detail. This type of estimate relies on the estimator's experience and judgment.

Usually, the tool and die estimator is estimating tool cost without any tool or die drawings. The estimator typically works from a piece part drawing and must visualize what the tool or die looks like. Some estimators develop some level of detail in their estimate.

Material cost, for example, is usually priced out in some detail, and this brings greater accuracy to the estimator by reducing error. If the material part of the estimate has an estimating error of plus or minus 5 per cent and the remainder of the estimate has an estimating error of plus or minus 10 per cent, the overall error is reduced.

4.1.2 Budgetary

The budgetary estimate can also be a guesstimate but is used for a different purpose. The budgetary estimate is used for planning the cost of a piece part, assembly, or project.

This type of estimate is typically on the high side because the estimator understands that a low estimate could create real problems.

4.1.3 Using Past History

Using past history is a very popular way of developing estimates for new work. Some companies go to great lengths to ensure that estimates are developed in the same way actual cost is conducted.

This provides a way past history in developing new estimates. New advancements in group technology now provide a way for the microcomputer to assist in this effort.

4.1.4 Estimating in Some Detail

Some estimators vary the amount of detail in an estimate depending on the risk and dollar amount of the estimate. This is true in most contract shops. This level of detail might be at the operation level where operation 10 might be a turning operation and the estimator would estimate the setup time at 0.5 hours and the run time at 5.00 minutes. The material part of the estimate is usually calculated out in detail to reduce estimating error.

4.1.5 Estimating in Complete Detail

When the risk of being wrong is high or the dollar amount of the estimate is high, the estimator will develop the estimate in as much detail as possible.

Detailed estimates for machinery operations, for example, would include calculations for speeds, feeds, cutting times, load and unload times and even machine manipulations factors.

These time values are calculated as standard time and adjusted with an efficiency factor to predict actual performance.

4.1.6 Parametric Estimating

Parametric estimating is an estimating method developed and used by trade associations. New housing constructions can be estimated on the basis of cost per square.

There would be different figures for wood construction as compared with brick and for single strong construction as compared with multilevel construction.

Some heat-treating companies price work on a cost per pound basis and have different cost curves for different heat-treating methods.

4.1.7 Project Estimating

Project estimating is by far the most complex of all estimating tasks. This is especially true if the project is a lengthy one. A good example of project estimating is the time and cost of developing a new missile.

The project might take 5 years and cost millions of dollars. The actual manufacturing cost of the missile might be a fraction of the total cost.

Major projects of this nature will have a PERT network to keep track of the many complexities of the project. A team of people with a project leader is usually required to develop a project estimate.

4.2 STANDARD DATA

Standard data are defined as standard time values for all the manual work in an estimate standard

data provide the opportunity for the estimator to be consistent in developing an estimate.

4.2.1 How Standard Data are Developed?

Standard data are developed in a variety of ways depending on the industry that uses them. Experience shows that it is easier to develop standard data for machinery operation as compared with fabrication operation.

This is because machinery operations can be calculated by using speeds, feeds and lengths of cut to determine time values.

Most of the work content of a fabrication operation is manual effort rather than machine time, and for this reason reliable standard data for the fabrication industry are difficult to find. Listed below are the basic methods used to develop standard data.

4.2.2 Past History

Many companies use past history or actual performance on joules produced to develop standard data.

Developing standard data this way rarely considers the best method of organizing work. This method is popular in smaller companies that do not have industrial engineers or time study engineers.

4.2.3 Time Study

Larger, well-organised companies will develop standard data from stop-watch time studies. Time studies are used to establish rates of production.

However, when time studies are also used to establish standard data, care must be taken in defining element content so work content can be isolated.

Time study engineers must be taught how to establish the element content of their studies in a way that will permit the development of standard data.

4.2.4 Predetermined Time Standards

Another approach in the development of standard data is to use one of the many predetermined time standard systems like MTM or MOST.

This method has its advantages and disadvantages. The chiefly advantage is consistency of data, and the chief disadvantage is the amount of time necessary to develop the data.

Some predetermined time standard systems are now computerized, which shortens the development time.

4.2.5 Standard Data Specific to a Shop and Lot Size

It should be pointed out that “all standard data are specific to a given shop and lot size.” Standard data developed in a high-production shop under ideal methods are of little value to a job shop that runs lot, sizes of 10 parts each. The reverse is also true.

The use of efficiency factors or off standard factors can assist in using the same data for both conditions, but this is less than ideal.

The reverse use of learning curves, that is, backing up the curve, is a better method of repricing work for small lot sizes using this method, the same standard data can be used for high and low production.

4.3 MATERIALS AVAILABLE TO DEVELOP AN ESTIMATE

Materials available for developing an estimate vary widely depending on what is being estimated.

In most cases the quality of the estimate will depend on the amount of materials to make the estimate.

Estimating materials shown below is a listing of the materials available for making an estimate.

No drawings

In many cases there are no drawings of what is being estimated. One clear example of this is tool estimating. The estimator will develop an estimate for a progressive die, for example, by reviewing the price part drawing. Some die estimators will develop a strip layout for the part and then estimate the die cost station by station.

Sketches

Sometimes sketches of the parts represent the only information available. This is typically true for a budgetary estimate.

Line drawings

Loftings or line drawings are used for estimating in some industries. The pleasure boat industry represents an example. A full-scale lofting of a deck and hull is used to estimate both the material and labour for a new fiber glass boat.

Complete drawings

Complete drawings and specifications are available for estimating some work. The aircraft industry is one good example.

Many times the estimator will spend more time reading the specifications than developing the estimate. This is necessary because the specifications will often determine the part process.

4.4 METHODS OF ESTIMATES

4.4.1 Computer Estimating

Computer estimating has become very popular in recent years primarily because of the advent of the micro computer. Early efforts of computer estimating date back to the early 1970s but were cumbersome to use because they were on a mainframe and were card-driven.

No less than 15 U.S. companies now offer estimating software for a microcomputer. Because the computer estimating industry is new, there are no real standards for estimating programs. Some programs are nothing more than a way to organize the calculations of an estimate, while others calculate all the details of the estimate.

Advantages and disadvantages

Shown below are some of the major advantages of computer cost estimating.

Accuracy versus consistency

Computer estimates are very consistent, provided they calculate the detail of an estimate. Because these estimates are consistent, they can be made to be accurate.

Through the use of consistent efficiency factors or learning curves, estimates can be adjusted up or down. This is one of the chief advantages of computer cost estimating.

Levels of details

Some computer estimating systems provide different levels of estimating cost. The level of detail selected by the user depends on the dollar risk.

Many estimators produce an estimate in more detail because the computer can calculate speeds and feeds, for example, much faster than an estimator can a hand-held calculators.

Refinements

Some computer estimating systems provide many refinements that would be impossible for the estimator to do in any timely manner. One example is to adjust speeds and feeds for material hardness.

Typically, the harder the material the more slowly a part will be turned or bored. Another refinement is the ability to calculate a feed state and adjust it based on the width of a form tool.

Source code

Some companies offer the source code uncompiled to their users. This is important because it affords the user the opportunity to customize the software.

In addition, many companies have written their own software to do something that is not available on the market. If the source code is not compiled, the users can build upon a computer estimating system.

Disadvantages

The chief disadvantage of computer estimating is that no one estimating system can suit everyone's need. This is especially true if the source code is compiled and not customizable.

Another problem with computer estimating is that the estimator will, in all probability, have to change some estimating methods. Computer software for estimating cost is seldom written around one method of estimating.

4.4.2 Group Technology

Group technology is not new. It was invented by a Russian engineer over 30 years ago. Unfortunately the subject is not taught in many of our colleges and universities.

Group technology (GT) is a coding system to describe something. Several proprietary systems are on the market.

One such system, the MICAPP system, uses four code lengths, a 10-,15-,20-,25- digit code. The code length selected is based on the complexity of the piece part or tool being described.

Use for group technology

Shown below are several uses for group technology along with several examples of use both internally and externally.

Cost estimating

GT can be used very efficiently in estimating cost. Assume a company manufactures shaft-type parts. Also assume there is a computer data base named SHAFT that contains 10-digit code followed by a part number, that is, code part number, and so on.

When an estimator must estimate the cost of a new shaft, the process starts by developing a code that describes the characteristics of the part. The first digit in the code might be assigned the part length, while the second digit is assigned the largest diameter and so on.

Next, the code is keyed in and the computer finds all the parts that meet the numeric descriptions and points out the part numbers. The best fit is selected to be modified into a new part.

All the details of each description are retrieved. These include diameter, length of cut, number of surfaces, and the like. The estimator can alter these features and make the old part into a new one.

Actual performance

As the part is being produced, the estimated information is updated with actual performance and refined. This gives the estimator the ability to improve estimating accuracy, because the next time, the computer finds that part as one to be modified into a new one, the estimator is working with actual performance.

Other use for GT

There are many other uses for group technology one that is similar to estimating is variant process planning, in which a standard process plan is on file for each operation and can be modified into a new plan. One carbide tool manufacturer produced a line of carbide drills and reamers and in their series 10 line and they had 758 different designs.

After a matrix to describe these tools was developed, a code for each tool was developed and the database was established. The company conducted a redundancy search and found that 9% of the existing designs were either look-alikes or very similar. Now the company conducts a database search first when confronted with a new design.

4.4.3 Parametric Estimating

Parametric estimating is the act of estimating cost or time by the application of mathematical formulas.

These formulas can be as simple as multiples or as complex as regression models. Parametric estimating, sometimes referred to as statistical modeling, was first documented by the Rand Corporation in the early 1950's in an attempt to predict military hardware cost.

Use of parametric estimating

Many companies use some form of parametric estimating to develop sales forecasting. The four examples cited below will give the reader a good feel of how parametric estimating is used in a variety of different industries.

Construction industry

In developing a cost estimate for residential buildings, some cost estimators use a dollar value per square foot. The estimator constitutes curves based on different construction such as wood on brick buildings and single or multi-storey dwellings.

These numbers can then be multiplied by the number of square feet in the building. Some construction companies have refined this process to provide additional detail carpeting, for example, could have a separate multiplier.

Heat treating

Most commercial heat-treating companies price their work based on a cost per pound and heat-treating method.

Heat-treating costs are very difficult to define because many times more than one type of part is in the heat-treating furnace at the same time.

It is difficult to think of a more effective way to estimate cost for this type of industry.

Tool and die industry

As pointed out earlier, estimating cost for a progressive die can be very difficult because the estimator seldom has a die drawing to work from some tool and die shops have developed parametric estimating methods that take out some of the guesswork.

This method is known as the “unit value” method over a period of time, the estimator collects actual time values about dies being produced. Once the estimator is satisfied that the data are correct, they are over aged into usable hours.

As an example, this might include 4 hours for every inch of forming or 3 hours for every hole under 2 inches in diameter. The unit value can stand for several meanings. For flowing it is a number of inches being formed.

For holes under 2 inches, in diameter, it represents the number of holes. The estimator might establish a factor of 40 hours for a degree of difficulty. If the scrap cutter is “Standard” the unit value is 1.

If the scrap cutter is more difficult, the unit value might have a value of 1.5 where the hours allotted would be 60.

Helicopter transmission

A helicopter transmission is a large complicated assembly comprised of a planetary gear system, bevel gears, shafting, and housings. Budgetary estimates for a transmission are usually developed using a variety of parametric methods.

The housing costs are based on weight. The bevel gear cost is based on number of teeth, and the planetary gear cost is based on gear face width and number of teeth. If methods like these were not employed, it would take hundred man-hour to produce an estimate.

Collecting and testing data

The single most important activity in parametric estimating is data collection and testing. Once the estimator develops the estimating methods, enough sample data should be collected for a natural bell curve. Statistical testing of the curve is also very important.

Once the parametric data are used for estimating it is important to continually test them against actual performance and refine them as necessary.

(a) Other factors that affect cost estimating

There are other factors that affect the accuracy of a cost estimate. Several of these are cited below.

Project estimating

Inflation analysis and risk analysis come into play in project estimating. A multi-year estimate, such as many government contracts, is especially sensitive to both these factors.

Inflation

When the estimate is being developed for future time periods, inflation rates are very important considerations.

The three most popular measurements of inflation are the wholesale price index, the implicit price index, and the consumer index, the last being the most quoted.

Because inflation rates are difficult to estimate accurately most multi-year contracts have some provisions re-openers to renegotiate. An after-tax evaluation of a multi-year project provides a more accurate assessment because it take into consideration costs that are not sensitive to inflation.

These costs might be loans repayment, leases, and depreciation costs.

Risk analysis

Risk analysis is a series of methods used to quantify uncertainty. Most of these methods are math

models. Three broad classifications of risk associated with a project are cost, schedule, and performance. Some of the most popular methods of risk analysis are:

1. Program Evaluation and Review Technique (PERT).
2. Probabilistic Analysis of Network (PAN).
3. Risk Information System and Network Evaluation Technique (RISNET).

4.4.4 Statistical Estimating

The analysis of data through the use of statistical methods has been used for centuries. These data can be cost versus other information that leads to cost development.

The practitioner must have a well-founded background in the use and application of statistical methods because an endless array of methods is available, several of which are described below.

Parametric estimating

Statistical estimating is another form of parametric estimating. The parametric methods made industry oriented whereas the methods discussed below are universal.

Regression analysis

They form most popular of regression analysis are simple regression, multiple regression, log-linear regression and curvilinear regression.

Each math model is different and is designed for a specific use. Information can be regressed along a straight line or along a curve.

Statistical estimating methods are very useful in parametric estimating. To use any of these methods also requires the user to have a sound knowledge of “goodness of data fit”.

Math models are available to determine how well data fit a straight line, curve or log-linear relationship.

Computers

Because of the complex nature of statistical estimating, the use of a computer is required. Fortunately, many good commercial programs, many of which are not expensive, are available on the market.

4.5 IMPORTANCE OF REALISTIC ESTIMATES

If the estimated cost of a product proves later on, to be almost same as the actual cost of that product, it is a realistic estimate. The cost estimate may prove to be

- (i) A realistic estimate,
- (ii) An over-estimate, or
- (iii) An under-estimate.

- An over-estimate, later on, proves to be much more than the actual cost of that product.
- An under-estimate, later on, proves to be much lower than the actual cost of that product.
- Both over-estimate and under-estimate may prove to be dangerous and harmful for a concern. Assume that on the basis of an estimate, the concern has to fill up a tender enquiry.

The over estimate means the concern will quote a higher rate and thus will not get the job or contract. In case of an under-estimate, the concern will get the contract but it will not be able to complete the work within that small quoted amount and hence will suffer heavy losses.

This emphasizes the importance of making realistic estimates. Realistic estimates are very essential for the survival and growth of a concern.

4.6 ESTIMATING PROCEDURE

The estimating department is generally attached with the planning department and is controlled by production manager. The total procedure is considered to have three stages.

- (i) Fixing of design, accuracy and finish.
- (ii) Proper working of estimating department.
- (iii) Obtaining a delivery promise from the progress department in view of existing load on the shop.

The planning department sets down the requirements and specifications, type and quantities of materials, make out the drawing, lays down the methods and sequence of operations, machines to be used, allowed times and rates of labour etc. Main items to be estimated in order of sequence are as follows:

1. *Price list*: To prepare the list of all the components of the product.
2. *Buy or Manufacture*: To decide which components should be made in the factory itself and which component should be procured from the market.
3. *Weight of material*: Determination of the weight of the materials with various allowances.
4. *Material cost*: Determination of the material cost either at market price or at a forecast price.
5. *Outside purchases*: Determination of prices of outside purchases.
6. *Machinery or processing data*: Determination of cutting speeds and feeds for the materials selected and machining times for all operations.
7. *Labour cost*: Determination of labour cost of each operation from performance times and wage rates, including manufacturing and assembly and testing.
8. *Cost of tools and equipment*: Determination of cost of necessary special tools or equipment etc.
9. *Prime cost*: Determination of prime cost by adding labour cost into material cost.
10. *Factory overheads*: Determination of factory on cost and general overhead charges.
11. *Package and delivery charges*: Determination of package and delivery charges and also insurance charges if necessary.
12. *Total cost*: To calculate the total cost.
13. *Standard profit and sales price*: To decide standard profit and adding this into total cost so as to fix the sale price.
14. *Discount to be allowed*: To decide discount allowed to the distributors and adding this into sale price to get market price or catalogue price.
15. *Time of delivery*: Determination of time of delivery in collaboration with the progress department.
16. *Approval of management*: When the estimate is complete, it is entered into the 'Estimate form' and submitted to the directors and sales department for dispatch of the quotation or tender.

Estimate Form

Description..... Date.....
 Quantity..... Enquiry No.....
 Drawing No..... Customer.....

	<i>Item</i>	<i>Total Cost</i>	<i>Cost of Item</i>
1.	Material (.....) No. of Components Batch No.....		
2.	Operation (a) (b) (c) (d) Total: (Factory cost)	Labour Overhead	
3.	Office and Administrative Expenses. Total: (Induction cost)		
4.	Selling Expenses (a) Packing and Carriage (b) Advertisement and Publicity (c) Other Allied Expenses Total: (Ultimate cost)		
5.	Profit Total: (Selling price)		

4.7 DIVISION OF ESTIMATING PROCEDURE

The above said procedure for simplicity can be divided into following major groups:

1. Material Cost. 2. Direct Labour Cost.
3. Direct Expenses. 4. Various Overhead Expenses.

1. Material cost

This estimation is most important in cost estimation. In calculating material cost both direct and indirect materials should be taken into account. The estimation of materials for this job or product includes the calculation of quantities to be provided including allowances for scrap and wastage in cutting, punching, turning etc. and for spoilage in processing.

After calculating weights or volumes of materials required, the cost of materials is estimated from rate of material. The estimator should have full information about the availability of the material.

2. Labour cost

Next stage is the estimation of labour cost. For this purpose the estimator must have the knowledge of the operations which will be performed, tools to be used, machine that will be employed and the department in which the product is to work for different operations.

The labour cost is calculated by multiplying hourly rate of the worker by total time spent in processing a job. The total time spent includes the set up time, tear down time, operation time and other miscellaneous allowances such as personal, fatigue, tool sharpening and charging, checking etc.

3. Direct expenses

It includes any expenditure other than direct material and direct labour incurred on a specific cost unit such as

(i) Hire charges of special tools or equipments for a particular production order or product.

(ii) Cost of special layout, design or drawing.

(iii) Cost of jigs and fixtures/pattern specially meant for the particular job only.

4. Various overhead expenses

All expenses other than direct material, direct labour and other direct expenses are called overhead expenses. These include the expenses such as

(i) Indirect material cost: These expenses include the cost of oil greases, coolants, cotton waste, etc.

(ii) Industrial labour cost: These expenses include the salaries of supervisors, foreman, draftsman, designers, chowkidars, storekeepers, etc.

4.8 CONSTITUENTS OF A JOB ESTIMATE

The various constituents of estimating the cost of a product may be sub-divided as under:

(a) Design time.

(b) Drafting time.

(c) Method studies, time studies, planning and production time.

(d) Design, procurement and manufacture of special patterns, cores, core boxes, flasks, tools, dies, jigs and fixtures etc.

(e) Experimental work.

Cost Estimation 103

(f) Materials.

(g) Labour.

(h) Overheads.

Design time

The time required for designing a product is estimated either on the basis of similar product previously manufactured or on the judgement of the designer. This time is generally considerable in quantity. It should be taken as the important.

(i) Repairs and maintenances expenses of machines and tools.

(ii) Insurance premium on building and plants.

(iii) Expenses of power such as steam, gas, electricity, etc.

(iv) Depreciation on building, furniture and equipment.

(v) Administrative overhead or expenses: These expenses include the salaries of high officials, persons working in general office, telephone telegraph, stationary etc.

(vi) Selling expenses: These expenses include the salaries of salesman, commission to salesman, advertising, publicity expenditure.

(vii) Light and power expenses.

(viii) Packing expenses.

(ix) Supervisory staff expenses.

Planned as regard the various processes and time to be taken by each. In case of routine or repetitive jobs, the planning would be available in the records. This may be checked up and the necessary modifications required may be made. In case of new jobs its method studies and time studies must be carried out.

The jobs should be broken down into its elements. For each part, sub-assembly and complete assembly, the type and sequence of operation should be studied and planned. Times for various operation and the schedules for doing the work should be seen.

This time setting effect both the delivery date as well as the cost. In case of a special order requiring considerable time, a special calculation should be made by making some allowance factor in estimating the cost of the product. The standard man hour rate should be used for calculating the cost of the designing time.

Drafting time

The next step after the design of the component is the preparation of its drawing to be used by the worker during production. An experienced draughtsman is required to prepare them. He also estimates the time and cost of drafting a new product. The probable time for drafting and the cost of drafting are estimated on the basis of drawing of similar previous components, and the standard man hour rate.

Method studies, time studies, planning and production time

Before the product is actually put into production, the material situation and purchase requisition are investigated for different materials required for the product.

Now, the job must be produced. The main points to be considered for this purpose are cost of the equipment, labour, material, depreciation, overheads, repair and maintenance, special buildings if required, supervision and the time required to conduct the experimental work.

Materials

It is the most important factor in cost estimation of any component. While computing the cost of material both the direct and indirect material should be taken into account. For this purpose the calculations of the quantities of raw materials allowances for scrap, spoilage and wastage during cutting, punching, turning etc. should be made.

Now the cost of the material is estimated from the rate of the material design, procurement and manufacture of special patterns, core boxes etc. The cost of special patterns, core boxes, tools, jigs, fixtures, gauges, consumable cutting fads etc. required for manufacturing a product should be considered for estimation. This cost should be added to the estimated cost. This cost is generally estimated in close coordination with Tool Department.

Experimental work

Certain types of experimental work has to be carried out in case of new type of products or inventions. The main purpose of experimental work is to find the quickest, easiest, and cheapest way of manufacture product. When estimating the cost of the new or undeveloped type of products the estimator should be very careful to make proper allowances to the experimental work.

Labour

For estimating the labour cost, the estimator is to go into greater details. He must be in knowledge of the various operations to be performed, tool to be used, machines employed and the departments in which the product is to be manufactured.

He must also be conversant with the wage rate for different operations. For time calculations we must consider. "The set up time; the operation time including the handling and machine time; the tear down time and various allowances like personal fatigue, tool sharpening or changing, checking etc.

4.9 COLLECTION OF COST

The various components of cost of any product manufacturing in any production concern are

1. Prime cost = Direct material cost + Direct labour cost + Direct expenses (if any)
2. Factory cost = Prime cost + Factory overheads
3. Cost of production = Factory cost + Administrative overheads + Miscellaneous overheads (if any)
4. Total cost = Cost of production + Selling and distribution overheads

The selling price of any product manufactured can be arrived at by adding a certain percentage of profit to total cost.

The given stepped diagram explains the step-by-step procedure of arriving at selling price of any product manufactured.

4.10 ALLOWANCES IN ESTIMATION

A worker cannot work continuously without rest. His efficiency decreases as time passes due to fatigue etc. He also requires time for tool sharpening checking measurements and for personal calls. All these allowance are called miscellaneous allowances.

The allowances amount to 15% of total time. Miscellaneous allowances are classified as personal fatigue, tool changing of grinding, checking, oiling and cleaning allowances, filling coolant reservoir and disposing off scraps and surplus, stock, etc.

UNIT 5 PRODUCTION COST ESTIMATION

5.1 ESTIMATION OF MATERIAL COST

5.1.1 Determination of Material Cost

To calculate the material cost of the product the first step is to study drawing of the product and split it into simple standard geometrical shapes and to find the volume of the material in the product and then to find the weight. The volume is multiplied by density of the metal used in the product. The exact procedure to find the material cost is like this:

1. Study the drawing carefully and break up the component into simple geometrical shapes. (Cubes, prisms, cylinders, etc.)
2. Add the necessary machining allowances on all sides which are to be machined.
3. Determine the volume of each part by applying the formulae of mensuration.
4. Add the volumes of all the simple components to get total volume of the product.
5. Multiply the total volume of the product by the density of the material to get the weight of the material.
6. Find out the cost of the material by multiplying the cost per unit weight to the total weight of the material.

5.1.2 Mensuration in Estimating

Introduction

Mensuration is the science which deals with the calculation of length of lines, areas of surfaces and volumes of solids by means of mathematical rules and formulae. An estimator is often required to calculate the length, area of volume of a job he is going to perform.

Hence, he must be thoroughly acquainted with the rules and formulae of mensuration. The general formulae for calculating the volume of a simple solid having a uniform cross-sectional area throughout in the direction normal to the section considered, is to find the product of the cross-sectional area and the length of the solid in the direction normal to the section considered.

To calculate the volume of a complex solid, it should be divided into a number of simple geometric solids. The volume of all these parts are calculated separately and then added together to get the total volume.

The volume of a solid of revolution, as generated by the rotation of a plane area about a given axis in its plane, is equal to the product of the area of the revolving section and the length of the path covered by its centroid in describing a circle about the axis.

This theorem was given by Guldinus. Volume of a circular ring, a half-round rib surrounding the boss of a fly wheel, and V-groove of a V-belt pulley may be calculated by Guldinus theorem.

Centroids and area of plane figures

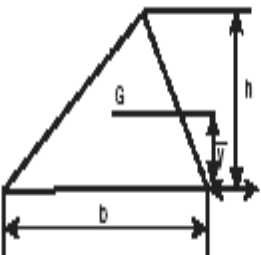
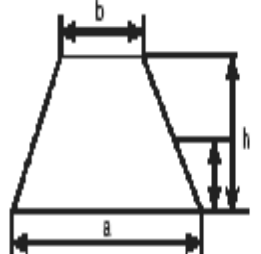
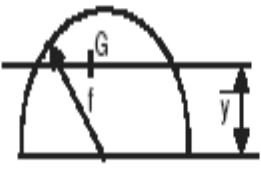
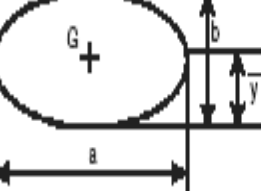
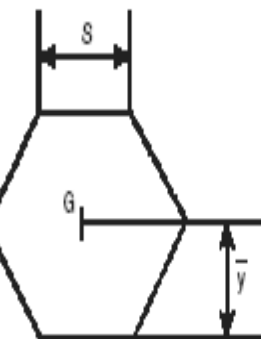
Name	Figure	Centroid	Surface area
Triangle		$\bar{y} = \frac{h}{3}$	$A = \frac{1}{2}bh$
Trapezium		$\bar{y} = \frac{h}{3} \frac{2a + b}{a + b}$	$A = \frac{1}{2}(a + b)h$
Semi circle		$\bar{y} = \frac{4r}{3\pi}$	$A = \frac{\pi r^2}{2}$
Ellipse		$\bar{y} = \frac{b}{2}$	$A = \pi ab$
Regular hexagon		$\bar{y} = \frac{\sqrt{3}}{2}S$	$A = \frac{3\sqrt{3}}{2}S^2$

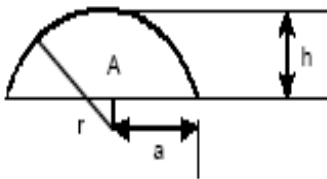
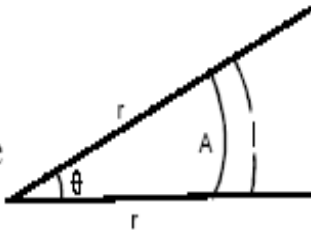
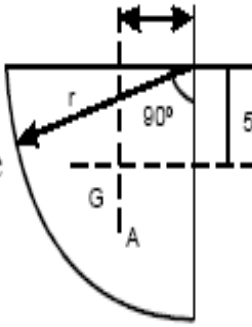
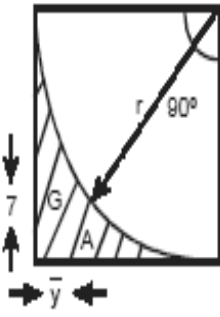
Name	Figure	Centroid	Surface area (A)
Segment of a circle		-	$A = \frac{4}{3} h \sqrt{a^2 + \frac{2}{5} h^2}$
Sector of a circle		-	$A = \frac{1}{2} r^2 \theta$ $= \frac{\theta}{360^\circ} \pi r^2 (\theta \text{ in degree})$
Quadrant of a circle		$\bar{x} = \bar{y} = \frac{4r}{3\pi}$	$A = \frac{\pi r^2}{4}$
Circular fillet		$\bar{x} = \bar{y} = 0.223 r$	$A = r^2 - \frac{\pi r^2}{4}$ $= \frac{1}{5} r^2$

Volumes and surface areas of solids

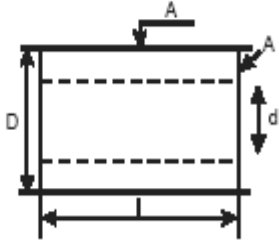
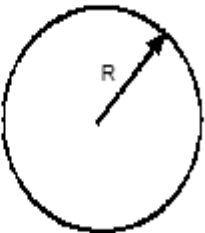
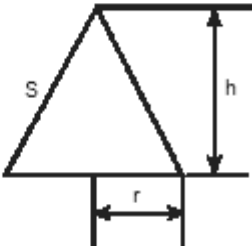
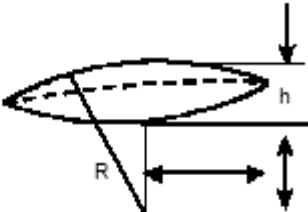
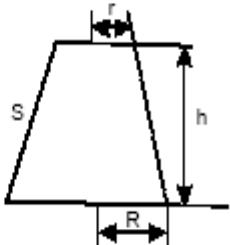
Name	Figure	Surface area (A)	Volume (V)
Hollow cylinder		Outer curved surface area $A = \pi Dt$ Flat surface area on each end $A^1 = \frac{\pi}{4} (D^2 - d^2)$	$V = \frac{\pi}{4} (D^2 - d^2) t$
Right sphere		$A = 4\pi R^2$	$V = \frac{\pi}{3} \pi R^3$
Right circular cone		Curve surface area $A = \pi r S$ $= \pi r \sqrt{r^2 + h^2}$ $[S = \sqrt{r^2 + h^2}]$	$V = \frac{1}{3} \pi r^2 h$
Segment of a sphere		Curved surface area $A = 2\pi R h$	$V = \frac{\pi h}{6} [3r^2 + h^2]$ $= \frac{\pi h^2}{3} [3R - h]$
Right truncated cone		Curved surface $A = \pi (R + r) S$ [When S = Slant height] $= \sqrt{[(R - r)^2 + h^2]}$	$V = \frac{\pi h}{3} [R^2 + r^2 + Rr]$

Regular truncated pyramid

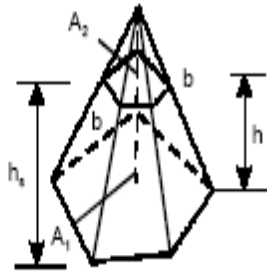

Slant surface area $V = \frac{h}{3}$

$$A = \frac{n h_s}{2} (a + b) \quad [A_1 + A_2 + \sqrt{A_1 A_2}]$$

n = Number of sides A_1 = Base area
 h_s = Perp. distance between parallel lines A_2 = Top flat area
 h = Vertical height
 ab along the slant surface of truncated pyramid.

Wedge

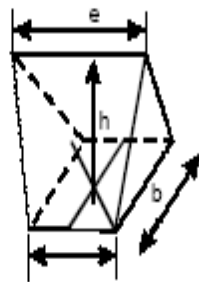

$$V = \frac{bh}{b} (2l + e)$$