

CLASSIFICATION OF LAYOUT (2016-2017)

Layouts can be classified into the following five categories:

1. Process layout
2. Product layout
3. Combination layout
4. Fixed position layout
5. Group layout

1- Process Layout

Process layout is recommended for batch production. All machines performing similar type of operations are grouped at one location in the process layout *e.g.*, all lathes, milling machines, etc. are grouped in the shop will be clustered in like groups. Thus, in process layout the arrangement of facilities are grouped together according to their functions. A typical process layout is shown in Fig. 1. The flow paths of material through the facilities from one functional area to another vary from product to product. Usually the paths are long and there will be possibility of backtracking.

Process layout is normally used when the production volume is not sufficient to justify a product layout. Typically, job shops employ process layouts due to the variety of products manufactured and their low production volumes.

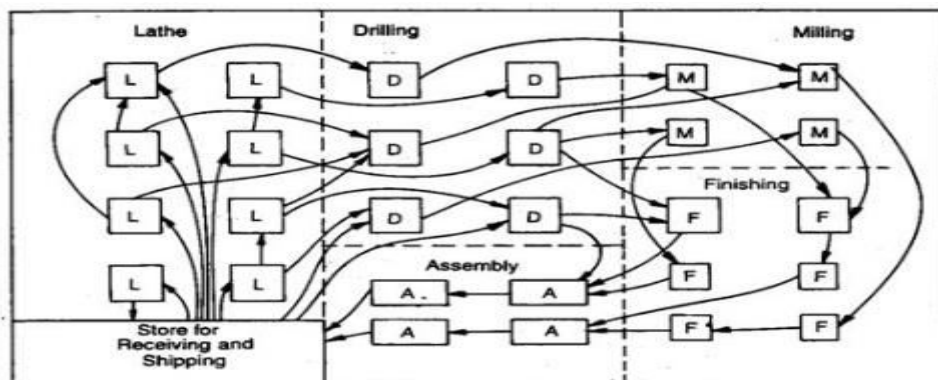

Fig. 1 Process layout

Advantages

1. In process layout machines are better utilized and fewer machines are required.
2. Flexibility of equipment and personnel is possible in process layout.
3. Lower investment on account of comparatively less number of machines and lower cost of general purpose machines.
4. Higher utilization of production facilities.
5. A high degree of flexibility with regards to work distribution to machineries and workers.

6. The diversity of tasks and variety of job makes the job challenging and interesting.
7. Supervisors will become highly knowledgeable about the functions under their department.

Limitations

1. Backtracking and long movements may occur in the handling of materials thus, reducing material handling efficiency.
2. Material handling cannot be mechanized which adds to cost.
3. Process time is prolonged which reduce the inventory turnover and increases the inprocess inventory.
4. Lowered productivity due to number of set-ups.
5. Throughput (time gap between in and out in the process) time is longer.
6. Space and capital are tied up by work-in-process.

2- Product Layout

In this type of layout, machines and auxiliary services are located according to the processing sequence of the product. If the volume of production of one or more products is large, the facilities can be arranged to achieve efficient flow of materials and lower cost per unit. Special purpose machines are used which perform the required function quickly and reliably.

The product layout is selected when the volume of production of a product is high such that a separate production line to manufacture it can be justified. In a strict product layout, machines are not shared by different products. Therefore, the production volume must be sufficient to achieve satisfactory utilization of the equipment. A typical product layout is shown in Fig. 2.

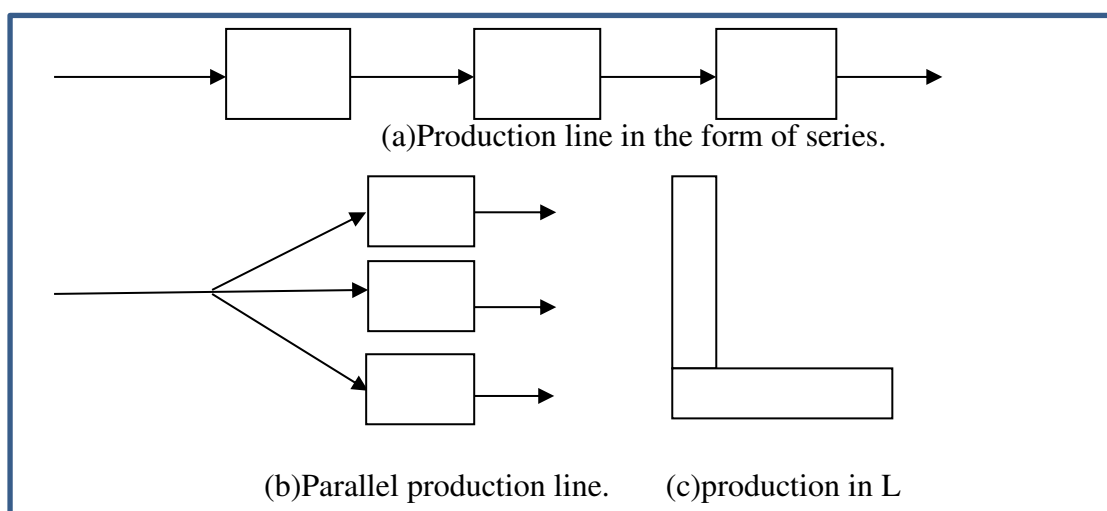

Fig. 2 Product layout

Advantages

1. The flow of product will be smooth and logical in flow lines.
2. In-process inventory is less.
3. Throughput time is less.
4. Minimum material handling cost.
5. Simplified production, planning and control systems are possible.
6. Less space is occupied by work transit and for temporary storage.
7. Reduced material handling cost due to mechanized handling systems and straight flow.
8. Perfect line balancing which eliminates bottlenecks and idle capacity.
9. Manufacturing cycle is short due to uninterrupted flow of materials.
10. Small amount of work-in-process inventory.
11. Unskilled workers can learn and manage the production.

Limitations

1. A breakdown of one machine in a product line may cause stoppages of machines in the downstream of the line.
2. A change in product design may require major alterations in the layout.
3. The line output is decided by the bottleneck machine.
4. Comparatively high investment in equipments is required.
5. *Lack of flexibility*. A change in product may require the facility modification.

3- Combination Layout

A combination of process and product layouts combines the advantages of both types of layouts.

A combination layout is possible where an item is being made in different types and sizes. It is to be noted that the sequence of operations remains same with the variety of products and sizes. Figure 3 shows a combination type of layout for manufacturing different sized gears.

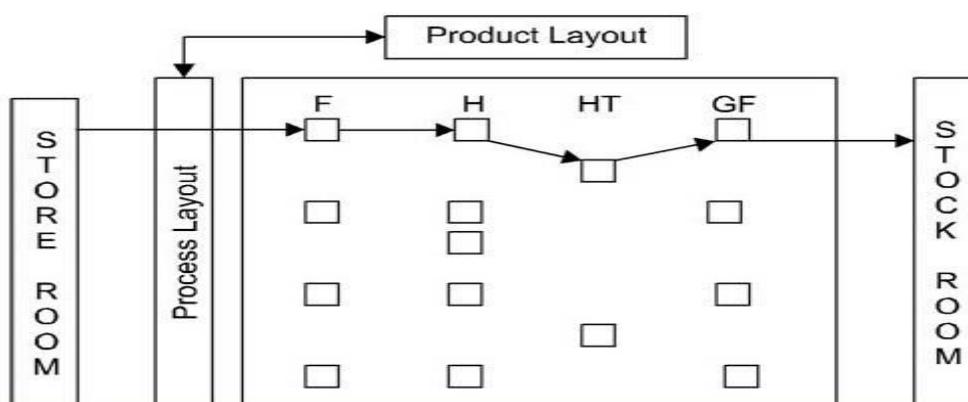

Fig. 3 Combination layout of product and process layout

4- Fixed Position Layout

This is also called the **project type** of layout. In this type of layout, the material, or major components remain in a fixed location and tools, machinery, men and other materials are brought to this location. This type of layout is suitable when one or a few pieces of identical heavy products are to be manufactured and when the assembly consists of large number of heavy parts, the cost of transportation of these parts is very high.

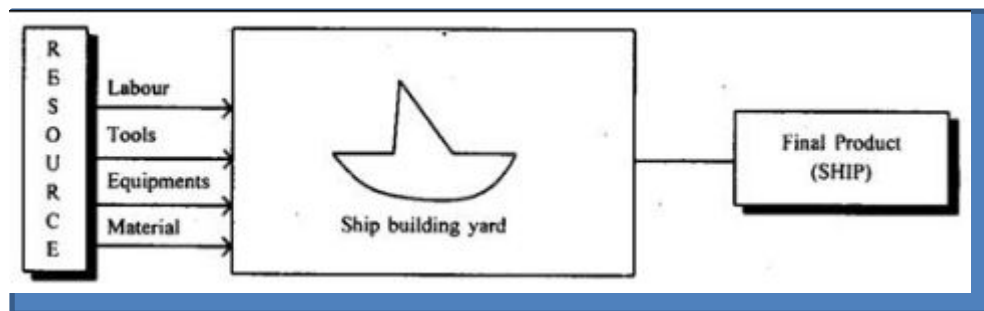

Fig. 4 Fixed position layout

Advantages

The major advantages of this type of layout are:

1. Helps in job enlargement and upgrades the skills of the operators.
2. The workers identify themselves with a product in which they take interest and pride in doing the job.
3. Greater flexibility with this type of layout.
4. Layout capital investment is lower.

3.5 Group Layout (or Cellular Layout)

There is a trend now to bring an element of flexibility into manufacturing system as regards to variation in batch sizes and sequence of operations. A grouping of equipment for performing a sequence of operations on family of similar components or products has become all the important.

Group Technology (GT) is the analysis and comparisons of items to group them into families with similar characteristics. GT can be used to develop a hybrid between pure process layout and pure flow line (product) layout. This technique is very useful for companies that produce variety of parts in small batches to enable them to take advantage and economics of flow line layout.

The application of group technology involves two basic steps; first step is to determine component families or groups. The second step in applying group technology is to arrange the plants equipment used to process a particular family of components. This represents small plants within the plants. The group technology reduces production planning time for jobs. It reduces the set-up time.

Thus **group layout** is a combination of the product layout and process layout. It combines the advantages of both layout systems. If there are m -machines and n -components, in a group layout (Group-Technology Layout), the m -machines and n -components will be divided into distinct number of machine-component cells (group) such that all the components assigned to a cell are almost processed within that cell itself. Here, the objective is to minimize the intercell movements.

In-group technology layout, the objective is to minimize the sum of the cost of transportation and the cost of equipments. So, this is called as multi-objective layout. A typical process layout is shown in Fig. 5.

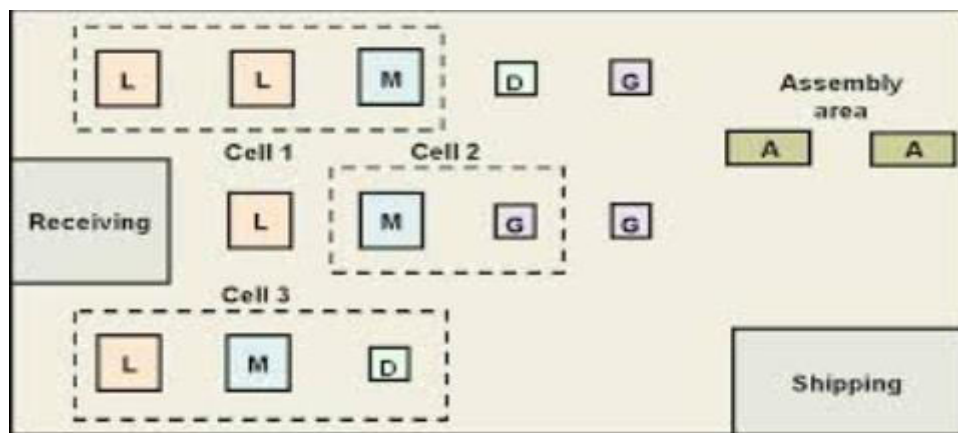

Fig. 5 Group layout or Cellular layout

Advantages of Group Technology Layout

Group Technology layout can increase;

1. Component standardization and rationalization.
2. Reliability of estimates.
3. Effective machine operation and productivity.
4. Customer service.

It can decrease the;

1. Paper work and overall production time.
2. Work-in-progress and work movement.
3. Overall cost.

Limitations of Group Technology Layout

This type of layout may not be feasible for all situations. If the product mix is completely dissimilar, then we may not have meaningful cell formation.