

BACTERIAL STAINING

basic methods

Deepankar ratha,
Assistant Professor,
CUTM, Rayagada

Why we should be Stain *Bacteria*

Bacteria have nearly the same refractive index as water, therefore, when they are observed under a microscope they are opaque or nearly invisible to the naked eye. Different types of staining methods are used to make the cells and their internal structures more visible under the light microscope.

.

Staining helps in observation of Bacteria

- **Microscopes are of little use unless the specimens for viewing are prepared properly. Microorganisms must be fixed & stained to increase visibility, accentuate specific morphological features, and preserve them for future use.**

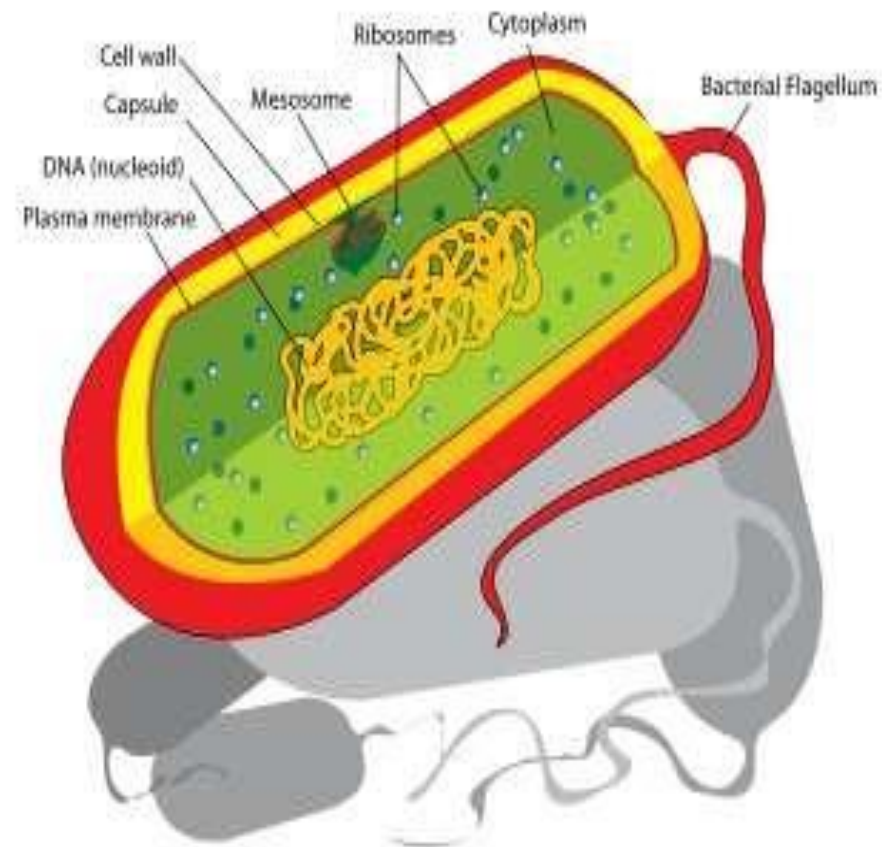

Stains and Staining

- Bacteria are slightly negatively charged at pH 7.0
 - Basic dye stains bacteria
 - Acidic dye stains background
- Simple stain
 - Aqueous or alcohol solution of single basic dye

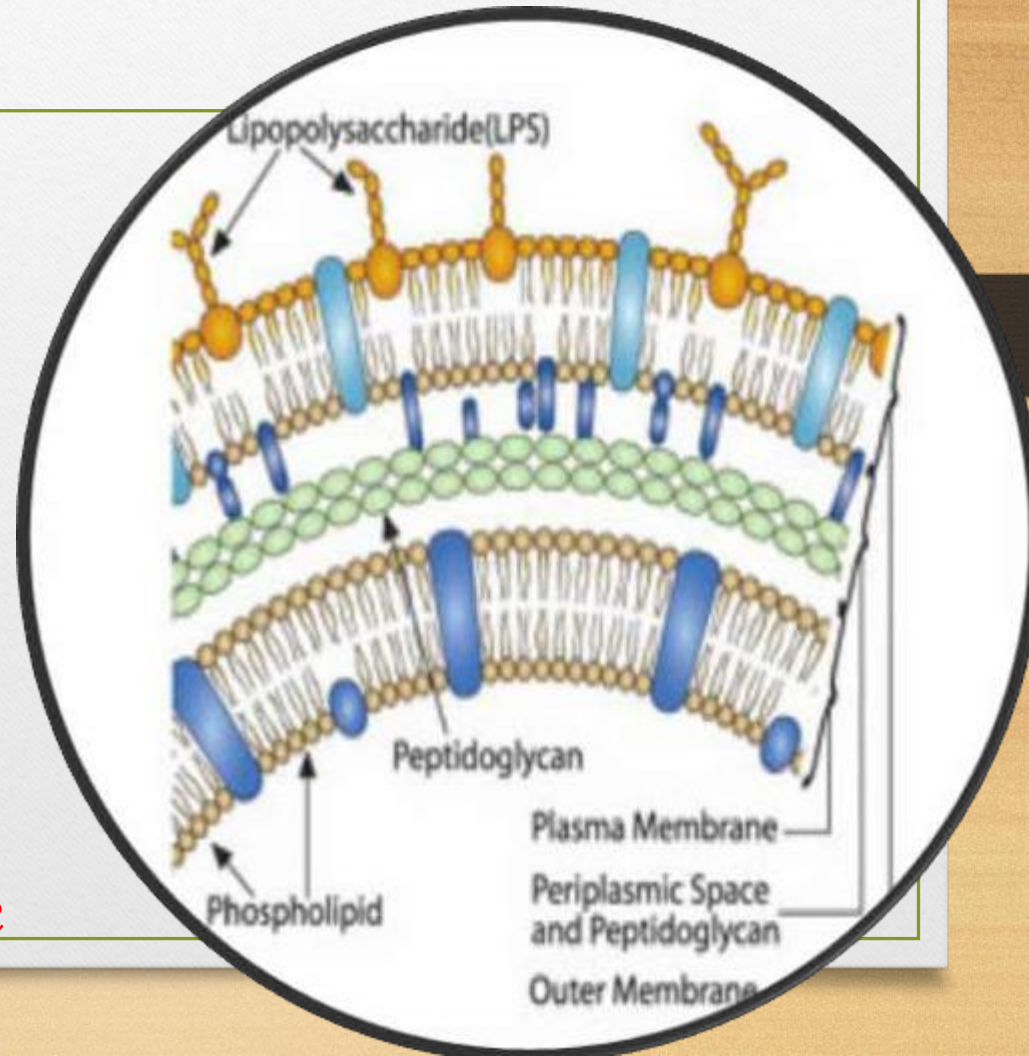

What is a Stain

- A stain is a substance that adheres to a cell, giving the cell color.
- The presence of color gives the cells significant contrast so are much more visible.
- Different stains have different affinities for different organisms, or different parts of organisms
- They are used to differentiate different types of organisms or to view specific parts of organisms

Staining Techniques

- **Staining** is an auxiliary technique used in microscopy to enhance contrast in the microscopic image. Stains and **dyes** are frequently used in biology and medicine to highlight structures in biological tissues for viewing, often with the aid of different microscopes.

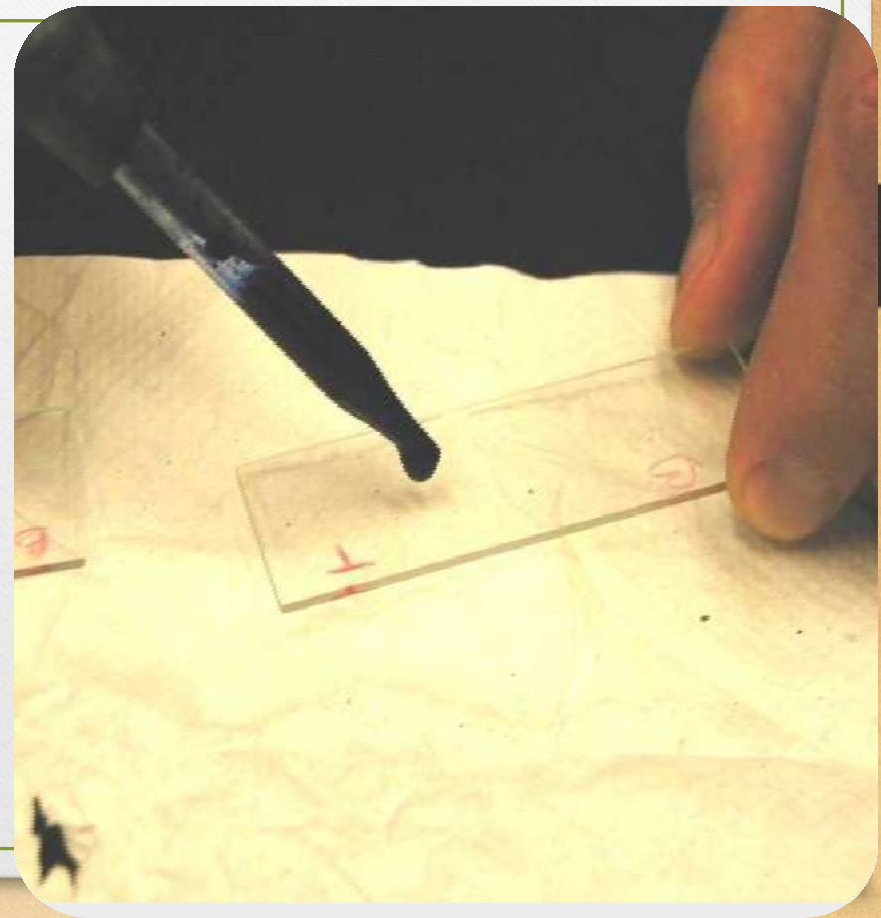

Smearing out of the *sample*



Fixation

- **Fixation**—which may itself consist of several steps—aims to preserve the shape of the cells or tissue involved as much as possible. Sometimes heat fixation is used to kill, adhere, and alter the specimen so it will accept stains



Simple staining

- *simplest, the actual staining process may involve immersing the sample (before or after fixation and mounting) in dye solution, followed by rinsing and observation.*
- *The stain can be poured drop by drop on the slide*



Simple staining

- Methylene blue, Basic fuchsin
- Provide the color contrast but impart the same color to all the organisms in a smear
- Loeffler's ethylene blue: Sat. solution of M. blue in alcohol - 30mlKOH, 0.01% in water - 100mlDissolve the dye in water, filter. For smear: stain for 3'. For section: stain

Simple staining (cont..)

- Dilute Carbol fuchsin:- Made by diluting Z-N stain with 10- 15 times its volume of water- Stain for 20-25 seconds, wash with water

Use: To demonstrate the morphology of *Vibrio cholera*

Polychrome methylene blue:

Use: M'Fadyean's reaction - *B. anthracis*

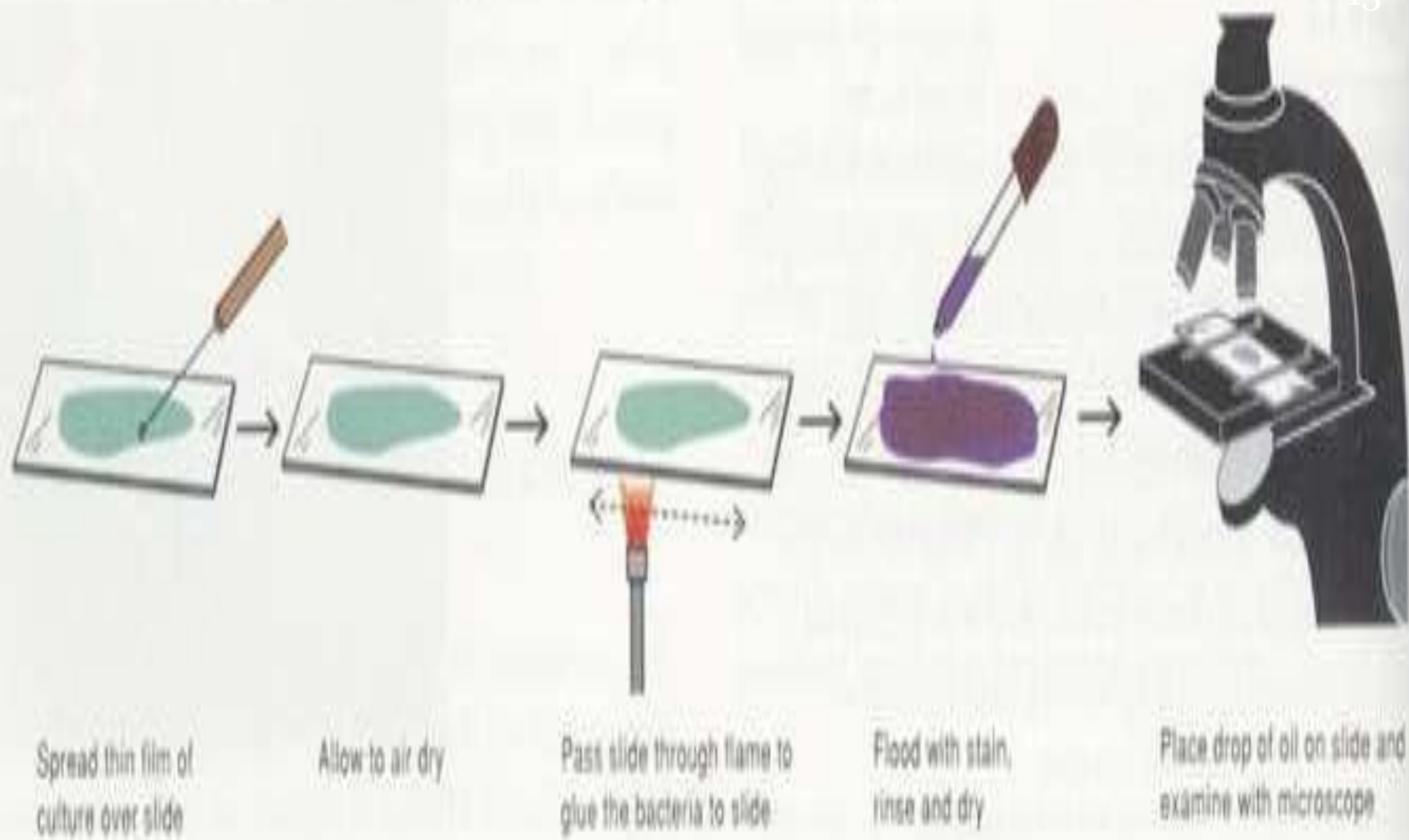
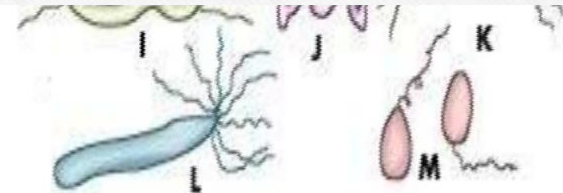

Figure 3.4

Steps in staining cells for microscopic observation.

Bacterial arrangement

- Clusters (group).
- Chains.
- Pairs (diploids).
- No special arrangement.



A. Micrococcus B. Diplococcus C. Staphylococcus D. Streptococcus E. Bacillus
 F. Corynebacterium G. Bacillus typhi H. Proteus I. Spirillum J. Cyphillis Bacteria.
 K. Nitrogen fixing bacteria. L. Thiospillum. M. Vibrio

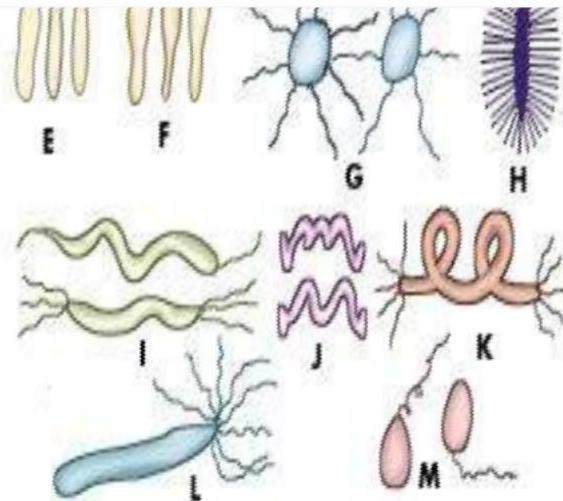

A. Micrococcus B. Diplococcus C. Staphylococcus D. Streptococcus E. Bacillus
 F. Corynebacterium G. Bacillus typhi H. Proteus I. Spirillum J. Cyphillis Bacteria.
 K. Nitrogen fixing bacteria. L. Thiospillum. M. Vibrio

Simple Staining Easier to Perform But has Limitations

- Simple easy to use; single staining agent used; using basic and acid dyes.
- Features of dyes: give coloring of microorganisms; bind specifically to various cell structures

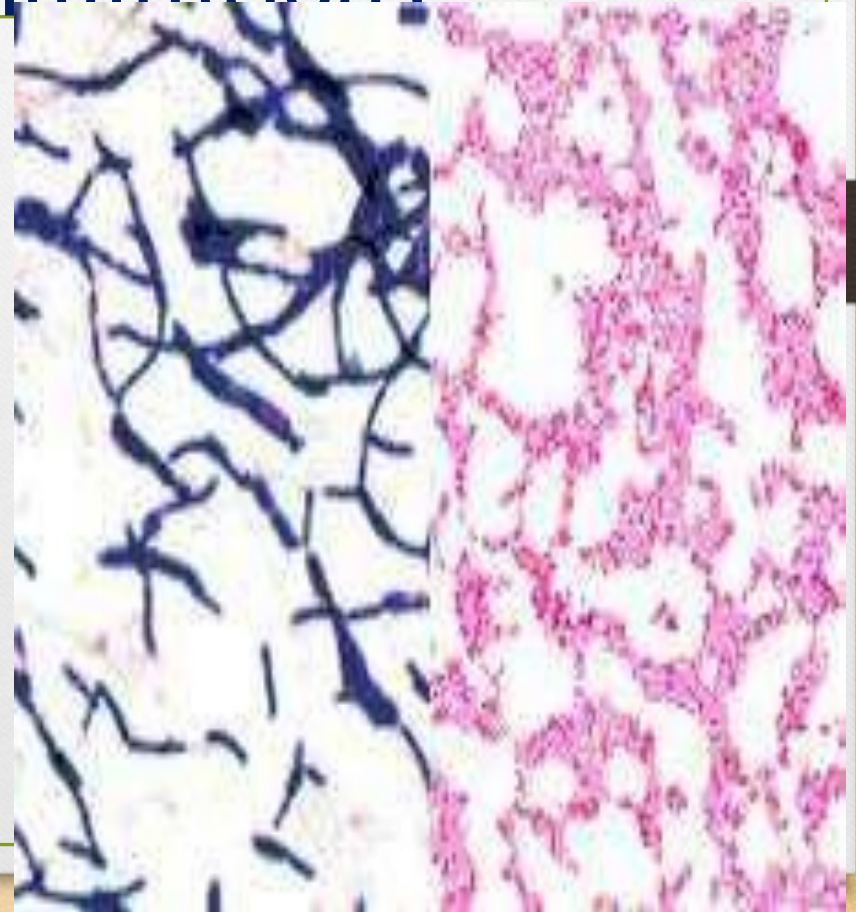

Differential Stains









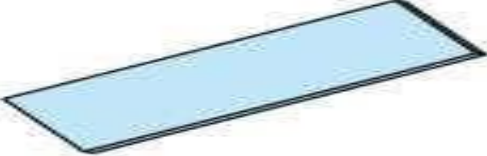

- ➡ **Differential Stains** use two or more stains and allow the cells to be categorized into various groups or types.
- ➡ Both techniques allow the observation of cell morphology, or shape, but differential staining usually provides more information about the characteristics of the cell wall (Thickness).

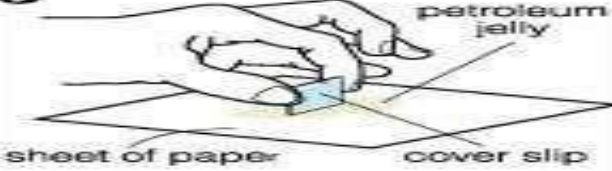
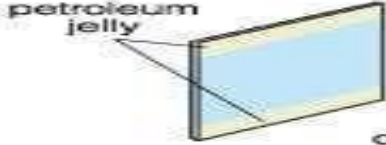
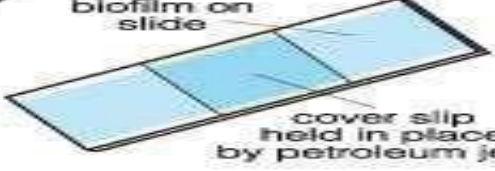
Gram staining

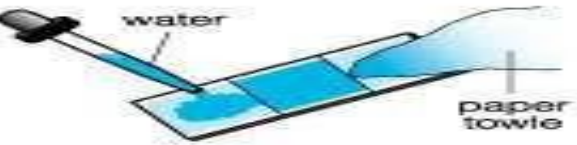
- Named after Hans Christian Gram, differentiates between Gram-positive purple and Gram-negative pink stains and is used to identify certain pathogens.



GRAM STAINING

	<p>1</p> 	<p>2</p> 
<p>Flow Through Procedure</p>	<p>Wipe bottom of biofilm slide clean</p>	<p>Clean top edges of slide about 2mm</p>
<p>3</p> 	<p>4</p> 	<p>5</p> 
<p>Build up a ridge of petroleum jelly on the top and bottom of a cover slip</p>	<p>Cover slip with petroleum jelly</p>	<p>Biofilm on slide with cover slip</p>
<p>6</p> 	<p>7</p> 	<p>8</p> 
<p>Add crystal violet-wait 30 sec.</p>	<p>Wash with water</p>	<p>Add Grams Iodine -wait 1.5 min.</p>
<p>9</p> 	<p>10</p> 	<p>11</p> 
<p>Decolorize with alcohol</p>	<p>Wash with water</p>	<p>Stain with Safranin dye-wait 30 sec.</p>
<p>12</p> 	<p>13</p> 	
<p>Wash with water</p>	<p>Examine under oil immersion through the cover slip</p>	

Gram staining - Principles

- Gram staining is used to determine gram status to classify bacteria broadly. It is based on the composition of their cell wall. Gram staining uses crystal violet to stain cell walls, iodine as a mordant, and a fuchsin or safranin counterstain to mark all bacteria. Gram status is important in medicine; the presence or absence of a cell wall will change the bacterium's susceptibility to some antibiotics.
- Gram-positive bacteria stain dark blue or violet. Their cell wall is typically rich with peptidoglycan and lacks the secondary membrane and lipopolysaccharide layer found in Gram-negative bacteria

Gram Staining Steps

1. **Crystal violet** acts as the primary stain. Crystal violet may also be used as a simple stain because it dyes the cell wall of any bacteria.
2. **Gram's iodine** acts as a mordant (Helps to fix the primary dye to the cell wall).
3. Decolorizer is used next to remove the primary stain (crystal violet) from Gram Negative bacteria (those with LPS imbedded in their cell walls). Decolorizer is composed of an organic solvent, such as, acetone or ethanol or a combination of both.)
4. Finally, a counter stain (Safranin), is applied to stain those cells (Gram Negative) that have lost the primary stain as a result of decolorization

Stains differentiates different groups of Bacteria

- To distinguish different kinds of bacteria into separate groups based on staining properties
- Two types: Gram stain & Acid-fast stain.

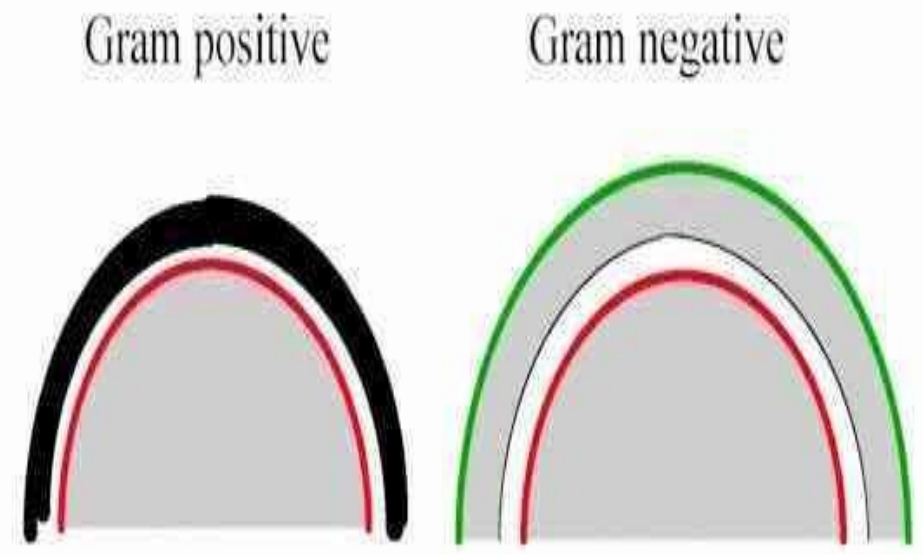

Red: cell membrane
Black: peptidoglycan
Green: Outer membrane

Differential Stains: Gram Stain

	Color of Gram + cells	Color of Gram – cells
Primary stain: Crystal violet	Purple	Purple
Mordant: Iodine	Purple	Purple
Decolorizing agent: Alcohol-acetone	Purple	Colorless
Counterstain: Safranin	Purple	Red

Gram Staining technique

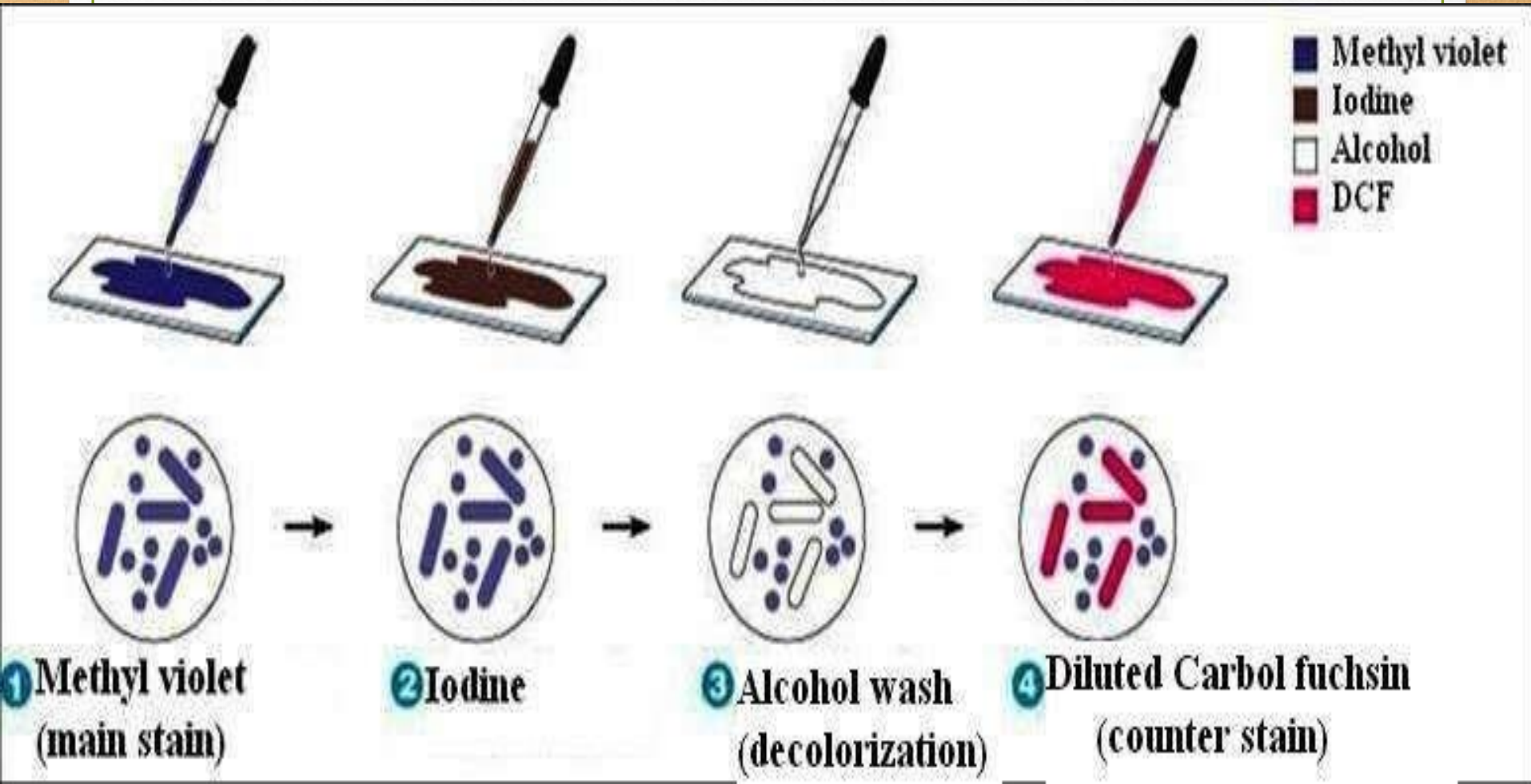

Gram Staining Procedure



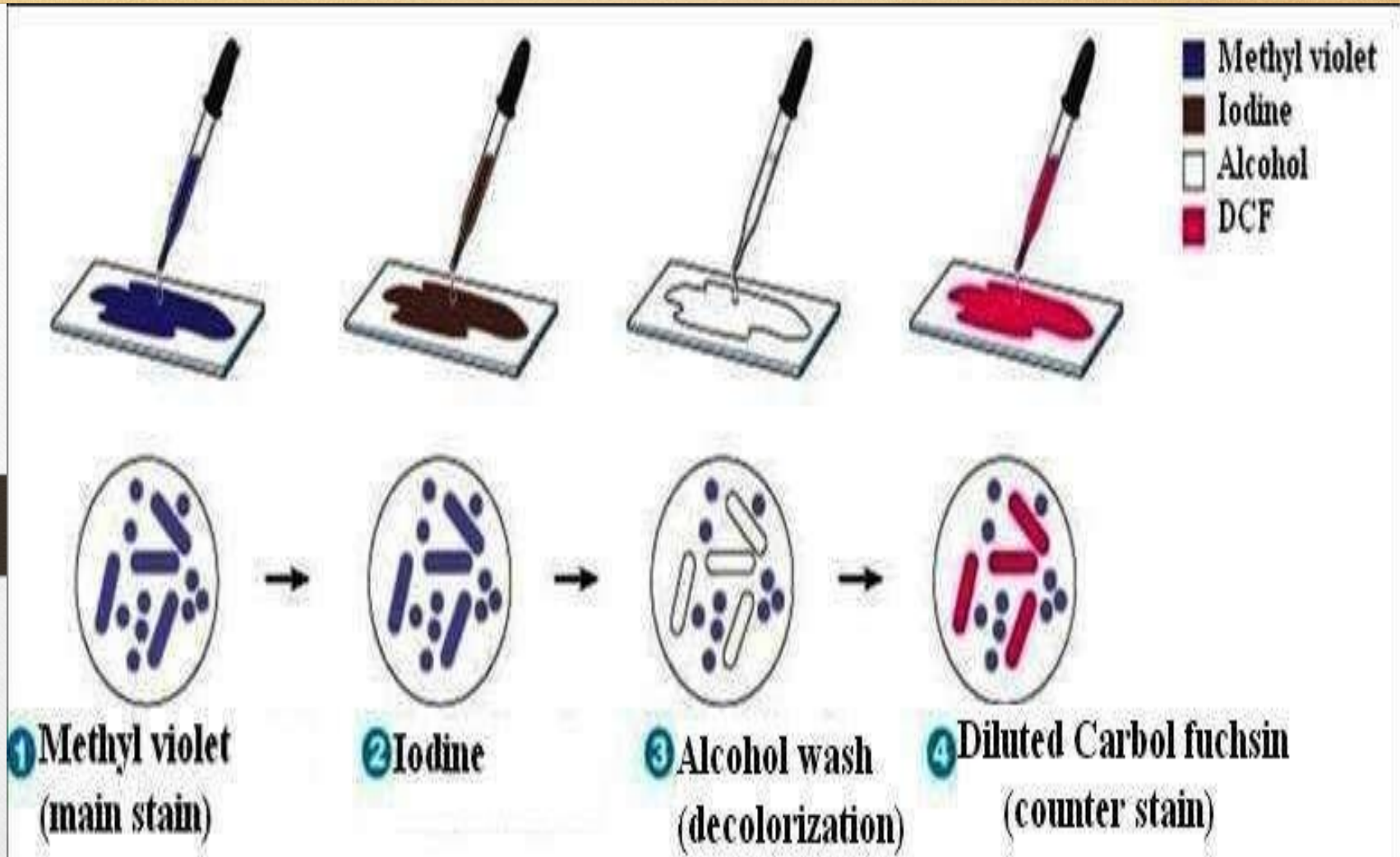

Gram Staining technique

Structure and Reactivity to *Gram Staining.*

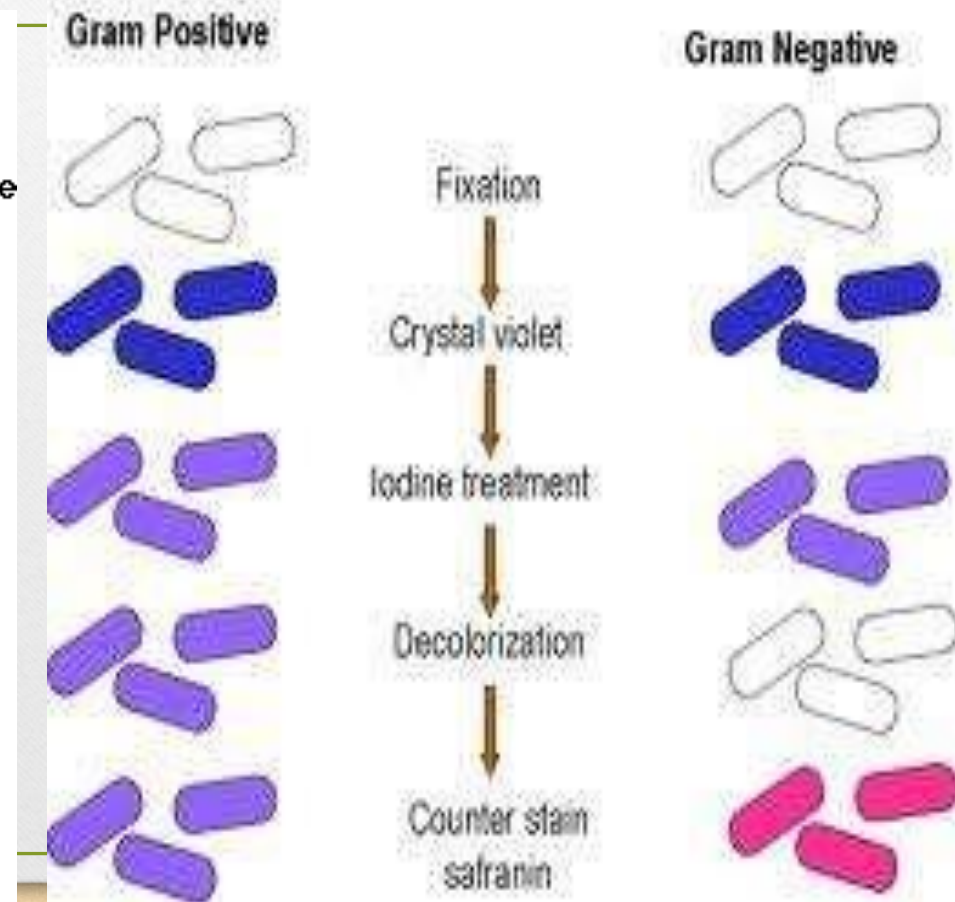
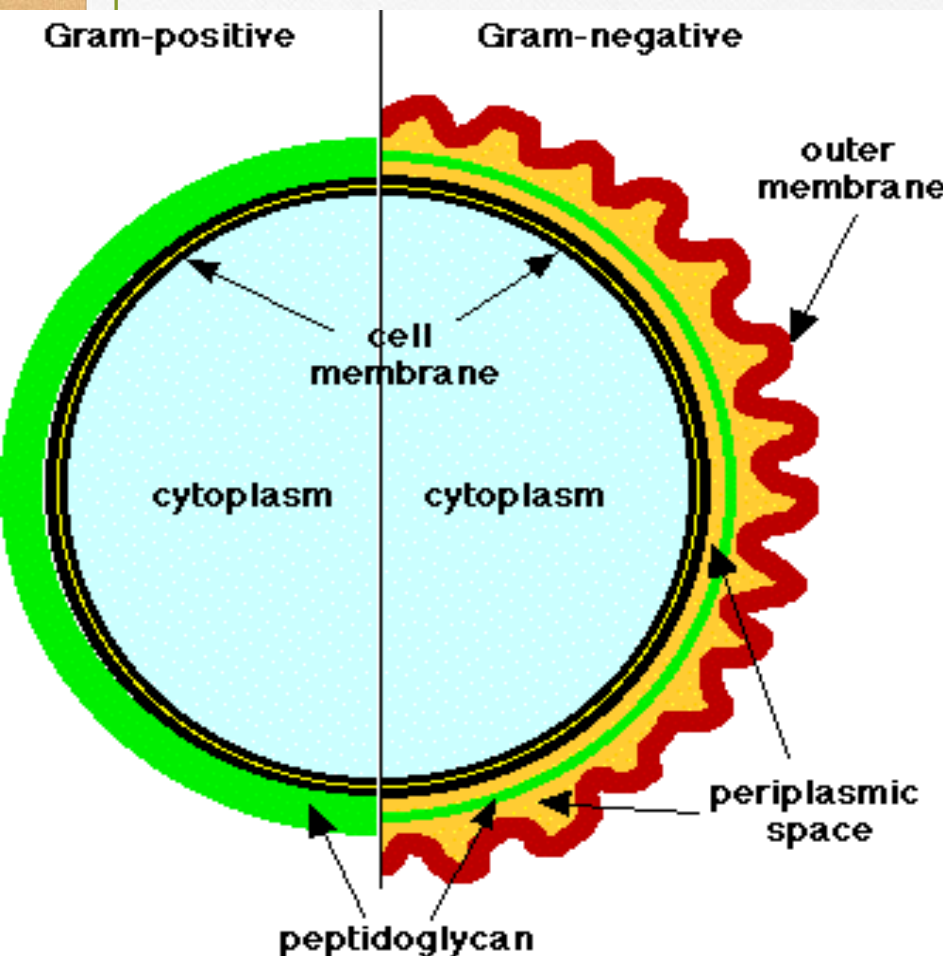

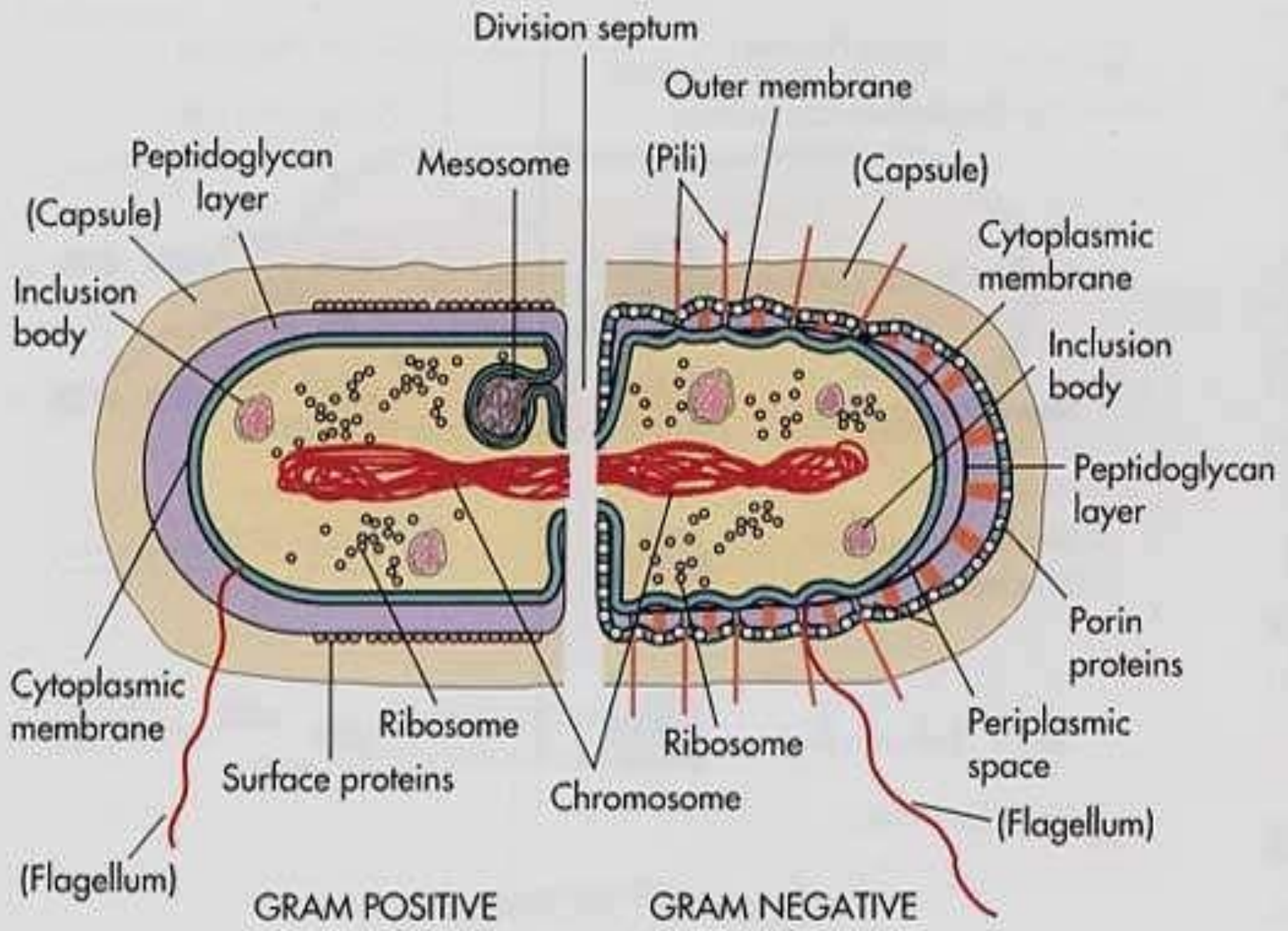

Cell structure differentiates Gram positive from Gram Negative

Gram Positive

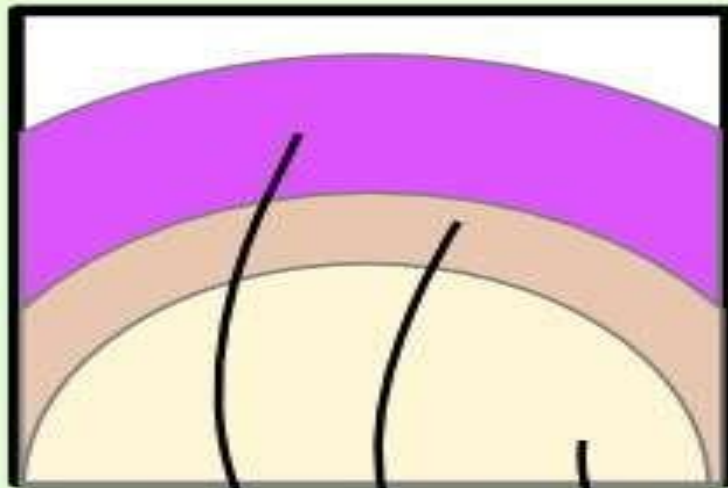

Gram Negative

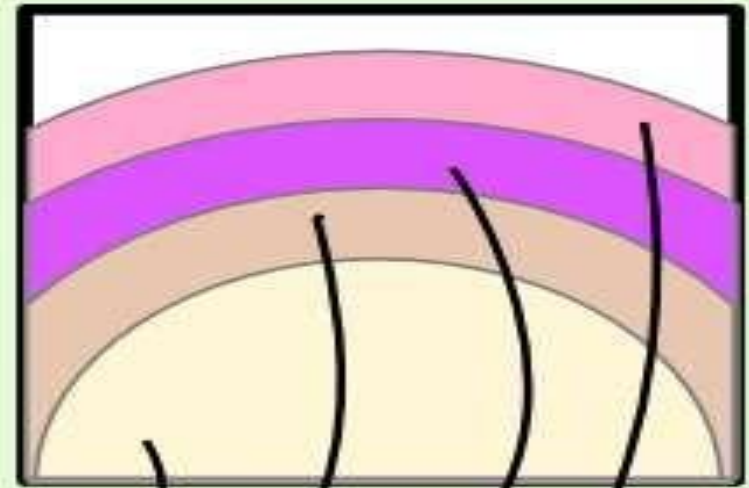

Cytoplasm
Cell Membrane
Peptidoglycan
Lippopolysaccharide

Gm+ve cocci & Gm-ve bacilli

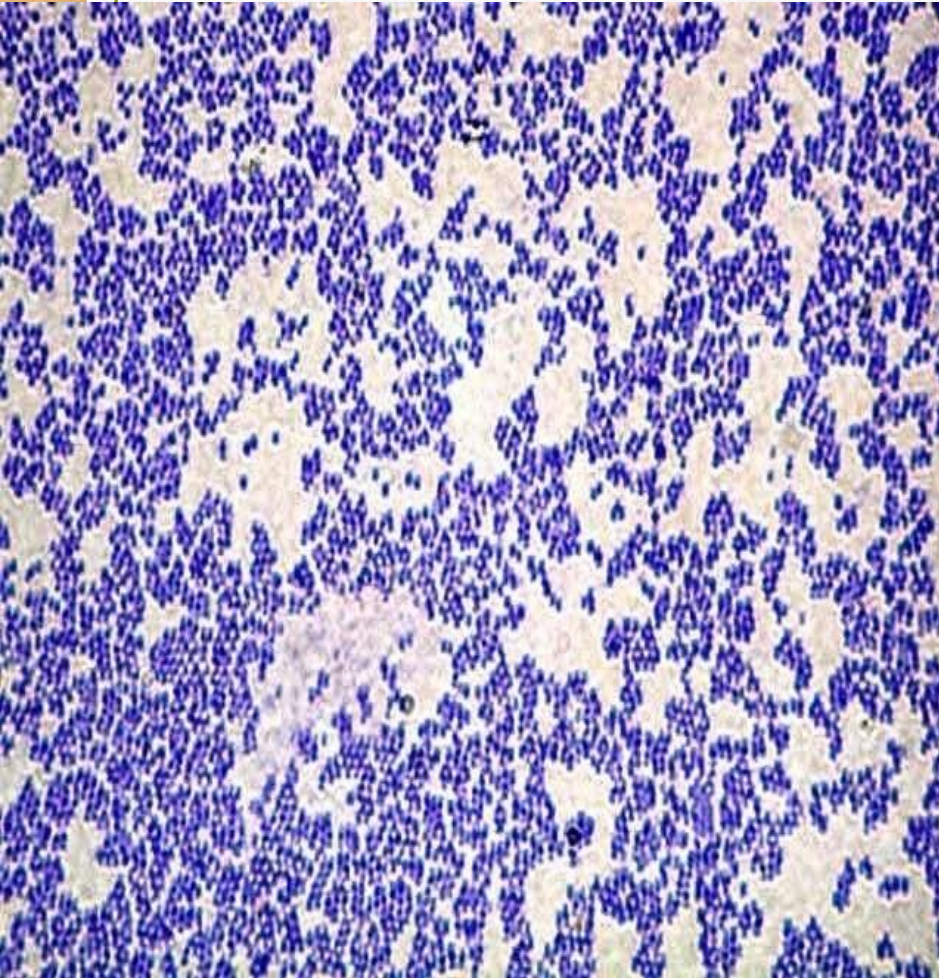

Gram-positive

- **Gram-positive** bacteria are those that are stained dark blue or violet by Gram staining. This is in contrast to Gram-negative bacteria, which cannot retain the crystal violet stain, instead taking up the counter stain (safranin or fuchsine) and appearing red or pink. Gram-positive organisms are able to retain the crystal violet stain because of the high amount of peptidoglycan in the cell wall. Gram-positive cell walls typically lack the outer membrane found in Gram-negative bacteria.

GRAM-POSITIVE BACTERIA

- GRAM-POSITIVE BACTERIA are characterized by having as part of their cell wall structure peptidoglycan as well as polysaccharides and/or teichoic acids. The peptidoglycans which are sometimes also called murein are heteropolymers of glycan strands, which are cross-linked through short peptides.

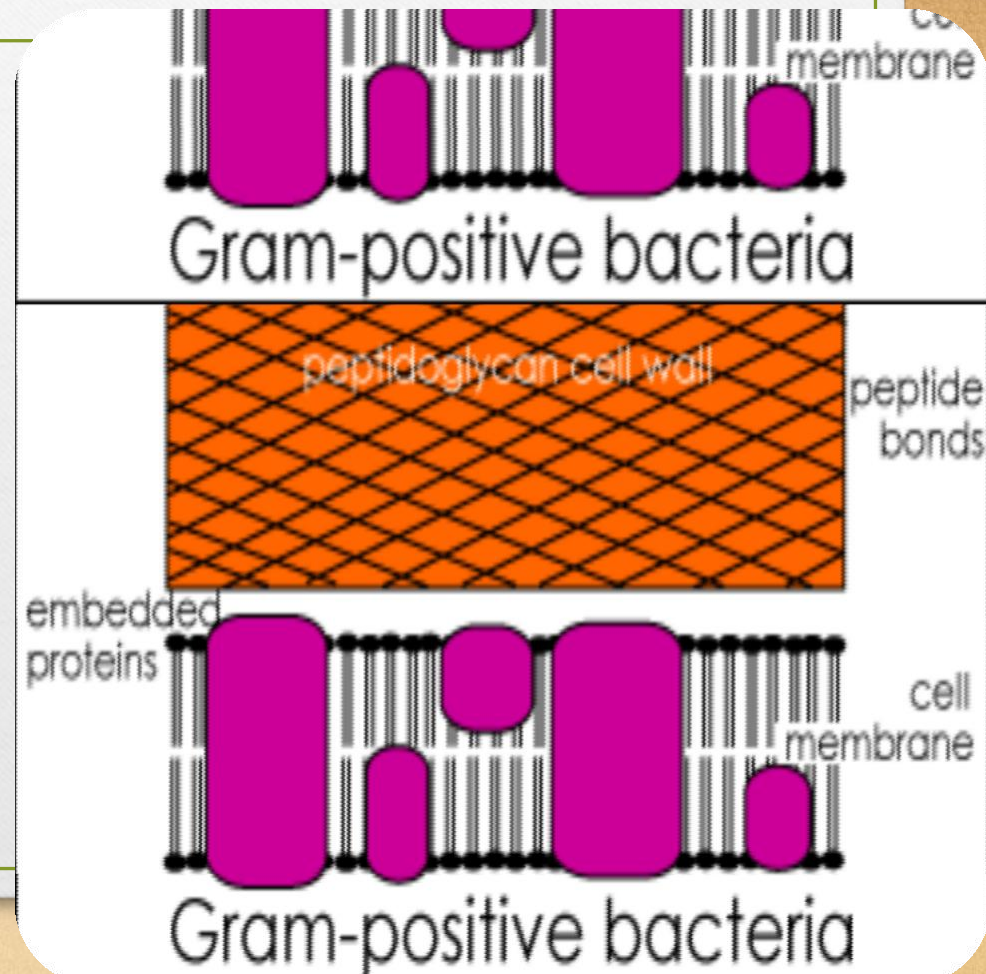

What are Gram Negative Bacteria

- **Gram-negative bacteria** are those bacteria that do not retain crystal violet dye in the Gram staining protocol. In a Gram stain test, a counter stain (commonly safranin) is added after the crystal violet, coloring all Gram-negative bacteria with a red or pink color. The test itself is useful in classifying two distinct types of bacteria based on the structural differences of their cell walls. On the other hand, Gram-positive bacteria will retain the crystal violet dye when washed in a decolorizing solution.

Gram negative bacteria

- On most Gram-stained preparations, Gram-negative organisms will appear red or pink because they are counterstained. Due to presence of higher lipid content, after alcohol-treatment, the porosity of the cell wall increases, hence the CVI complex (Crystal violet - Iodine) can pass through. Thus, the primary stain is not retained.

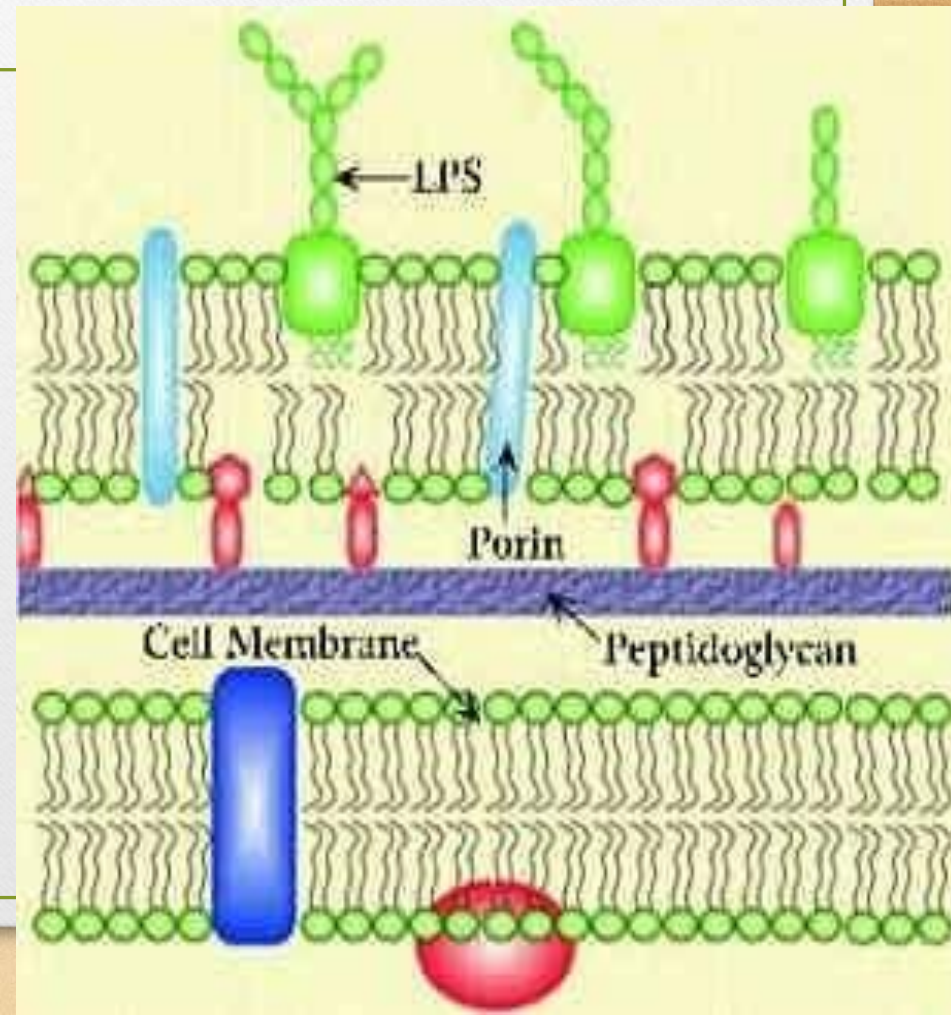

Structural Details of Gram -ve Bacteria

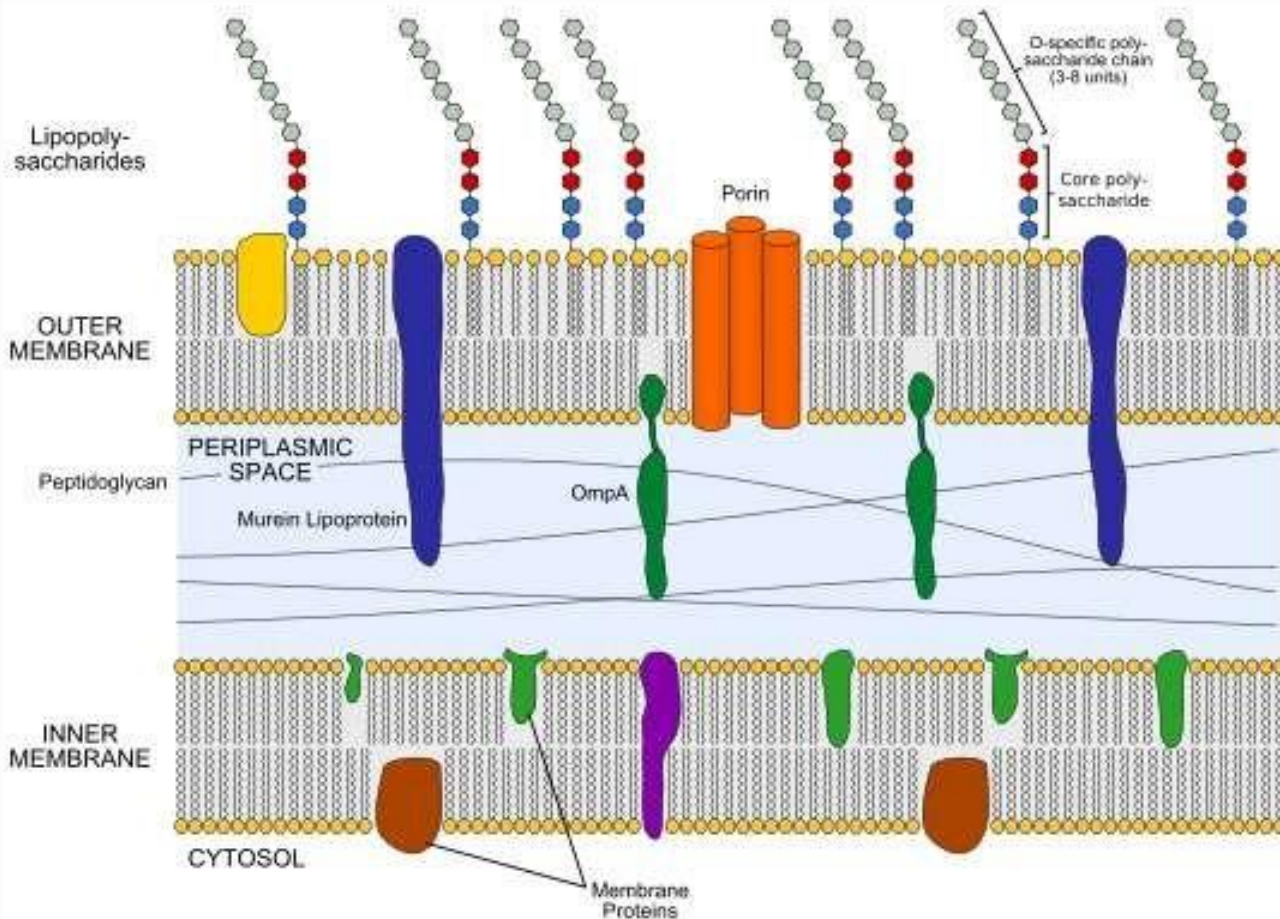

Gram Negative Bacterial Cell Wall

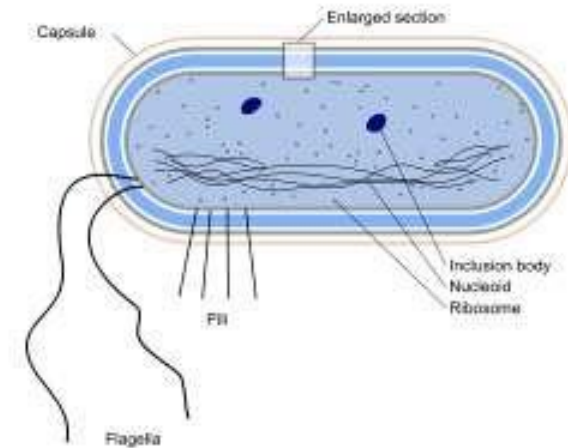

Gram Negative Bacteria

- Also, in contrast to most Gram-positive bacteria, Gram-negative bacteria have only a few layers of peptidoglycan and a secondary cell membrane made primarily of lipopolysaccharide

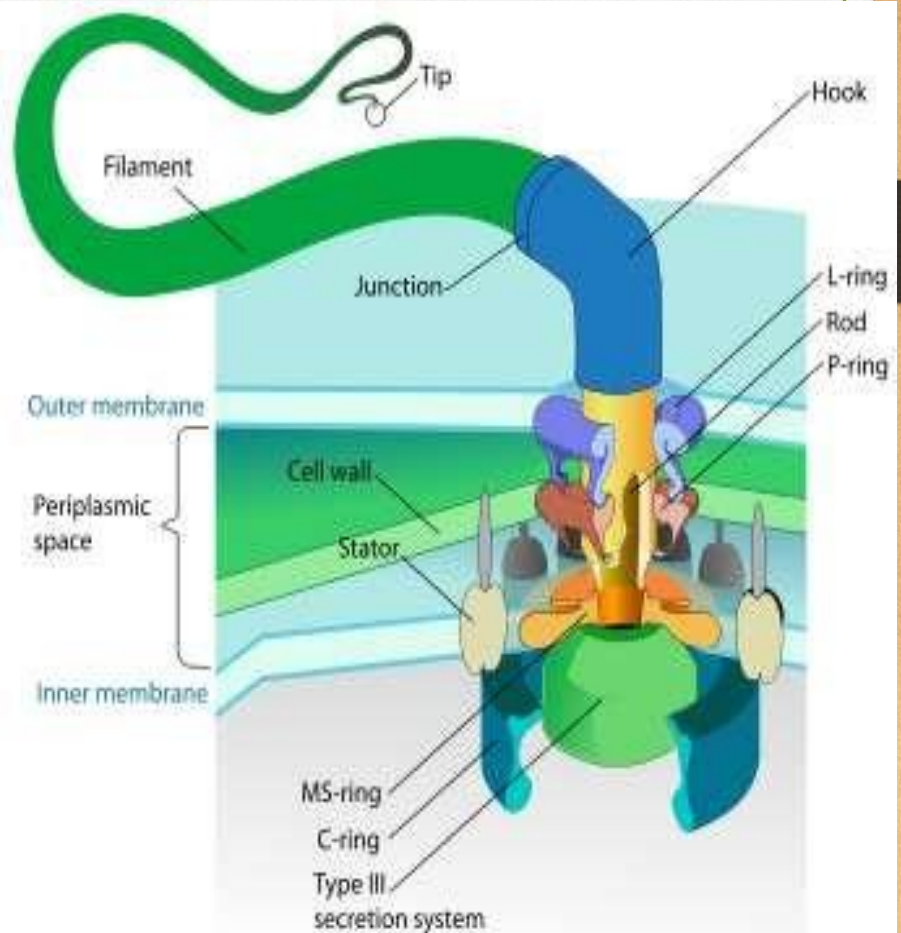

Common Questions

- 1 Principles of Gram Staining and its uses.
- 2 Name common/pathogenic Gram positive and Gram negative Bacteria
- 3 Why some bacteria are Gram positive and others Gram negative.
- 4 Why some bacteria cannot be stained by Gram's Method of staining.
- 5 What is the Use of Gram staining in your future clinical practice.

ACID FAST STAINING

Mycobacterium are Acid Fast Bacilli

- **Mycobacterium** are Gram-resistant (waxy cell walls), non-motile, pleomorphic rods, related to the Actinomyces. Most Mycobacteria are found in habitats such as water or soil. However, a few are **intracellular pathogens** of animals and humans. *Mycobacterium tuberculosis*, along with *M. bovis*,
- *M. africanum*, and *M. microti* all cause the disease known as tuberculosis (TB) and are members of the tuberculosis species complex. Each member of the TB complex is pathogenic, but *M. tuberculosis* is pathogenic for humans while *M. bovis* is usually pathogenic for animals.

Acid-Fast Stain

- Acid-fast cells contain a large amount of lipids and waxes in their cell walls
 - **primarily mycolic acid**
- Acid fast bacteria are usually members of the genus *Mycobacterium* or *Nocardia*
 - **Therefore, this stain is important to identify *Mycobacterium* or *Nocardia***

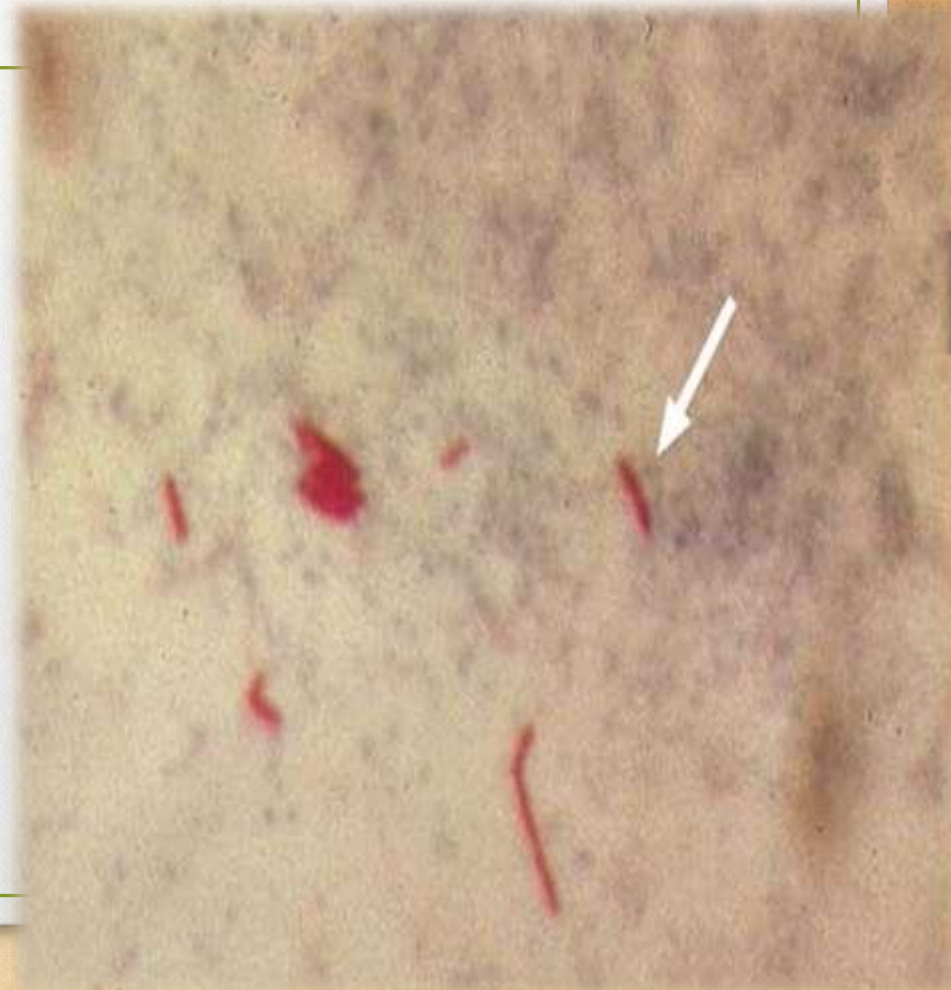

Ziehl-Neelsen stain

- Ziehl-Neelsen staining is used to stain species of *Mycobacterium tuberculosis* that do not stain with the standard laboratory staining procedures like Gram staining.
- The stains used are the red colored Carbol fuchsin that stains the bacteria and a counter stain like Methylene blue or Malachite green.

Acid-Fast Organisms

- Primary stain binds cell wall mycolic acids
- Intense decolorization does not release primary stain from the cell wall of AFB
- Color of AFB-based on primary stain
- Counterstain provides contrasting background

AFB Staining Methods

- Zeihl
- Neelsen's-hot stain
- Kinyoun's-cold stain
- Modifications

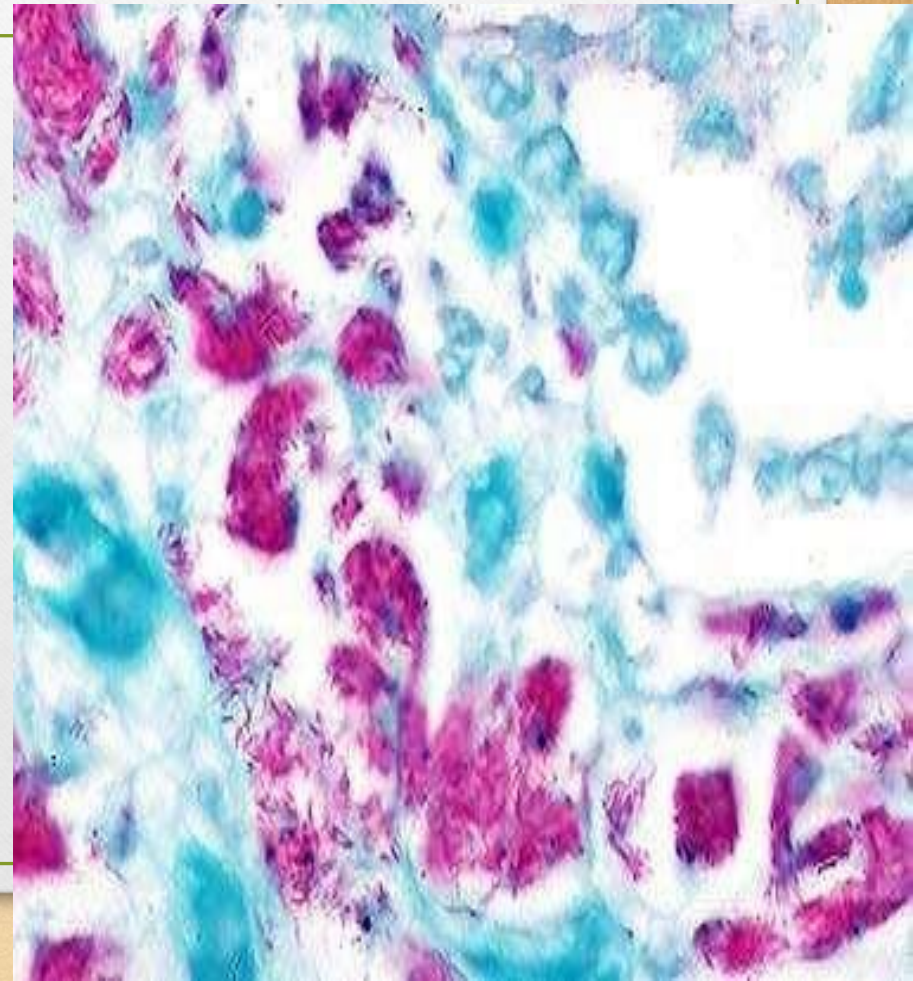

Ziehl- Neelsen Procedure

Make a smear. Air Dry. Heat Fix.

2. Flood smear with Carbol Fuchsin stain

- Carbol Fuchsin is a lipid soluble, phenolic compound, which is able to penetrate the cell wall

3. Cover flooded smear with filter paper

4. Steam for 10 minutes. Add more Carbol Fuchsin stain as needed

5. Cool slide

6. Rinse with DI water

7. Flood slide with acid alcohol (leave 15 seconds). The acid alcohol contains 3% HCl and 95% ethanol, or you can decolorize with 20% H₂SO₄

- *The waxy cell wall then prevents the stain from being removed by the acid alcohol (decolorizer) once it has penetrated the cell wall. The acid alcohol decolorizer will remove the stain from all other cells.*

Ziehl- Neelsen Procedure (continued)

8. Tilt slide 45 degrees over the sink and add acid alcohol drop wise (drop by drop) until the red color stops streaming from the smear
9. Rinse with DI water
10. Add Loeffler's Methylene Blue stain (counter stain). This stain adds blue color to non-acid fast cells!! Leave Loeffler's Blue stain on smear for 1 minute
11. Rinse slide. Blot dry.
12. Use oil immersion objective to view.

1

2

3

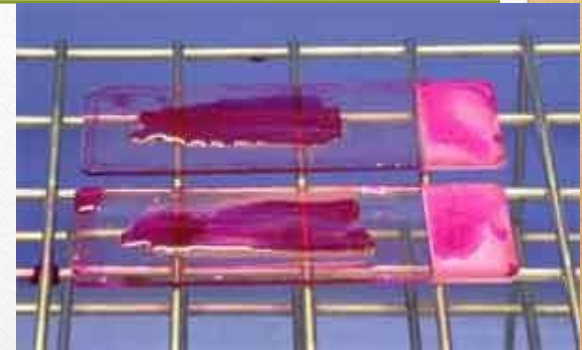

4

5

6



7



Ziehl-Neelsen stain

How the Acid fast bacteria *appear*



Fluorochrome AFB Microscopy

More rapid and sensitive
Specificity : same with sufficient expérience
Equipment cost , bulbs, technical demands for busy labs
External quality assessment should be done if this method is performed



Fluorescence and Bright-field Microscopy

Dr. T. V. K. M. D.

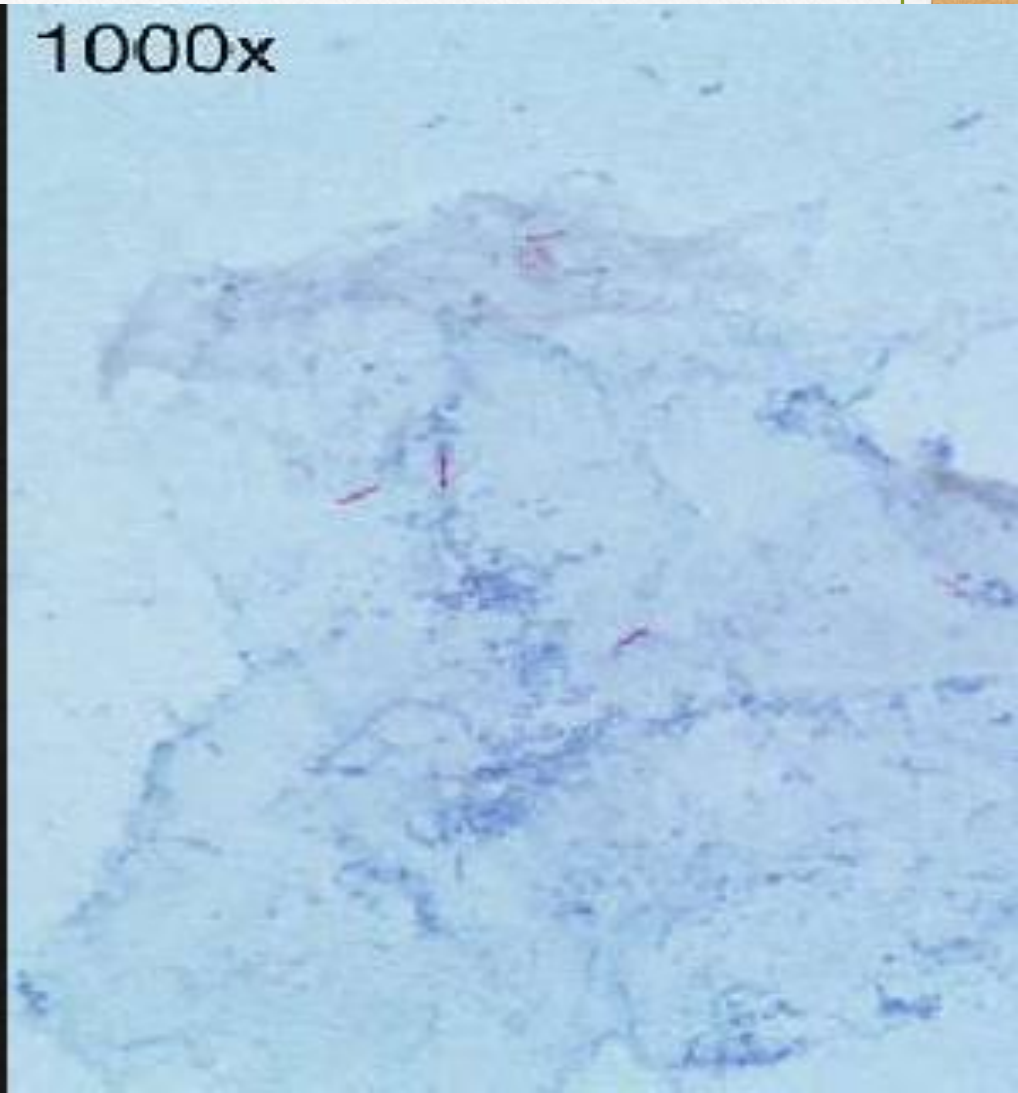

Fluorochrome AFB Microscopy

Primary fluorochrome

AFB fluoresces

Auramine O

Green

Auramine O-Rhodamine B

Yellow/orange

Acridine Orange

Yellow/orange

Note: Color of AFB may vary with filter system

Staining of *M. lepra*

- *M. lepra* are less acid fast than *M. tuberculosis* group of organisms,
- The concentration of H_2SO_4 is reduced to 5 % for decolorising

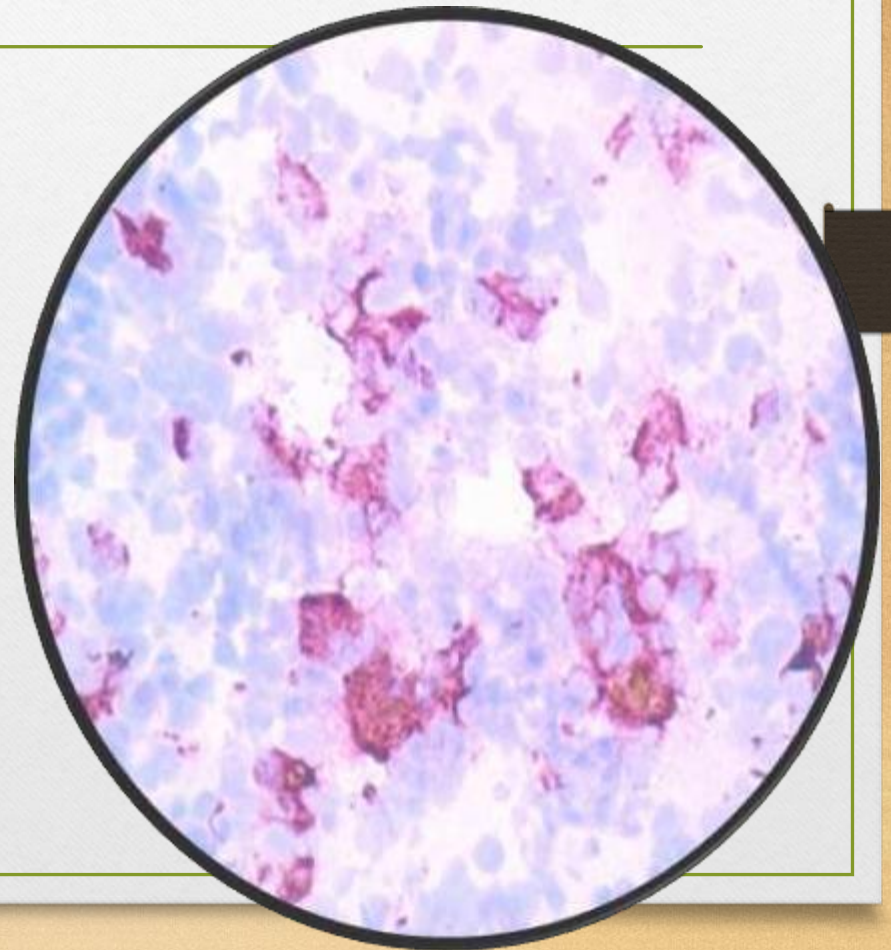

ALBERT'S STAINING FOR C.diphtheria

Diphtheria is Serious Disease

When you suspect Diphtheria

- In all cases of suspected cases of Diphtheria, stain one of the smears with Gram stain
- If Gram stained smear shows morphology suggestive of *C. diphtheria*, proceed to do Albert staining which demonstrates the presence or absence of metachromatic granules.

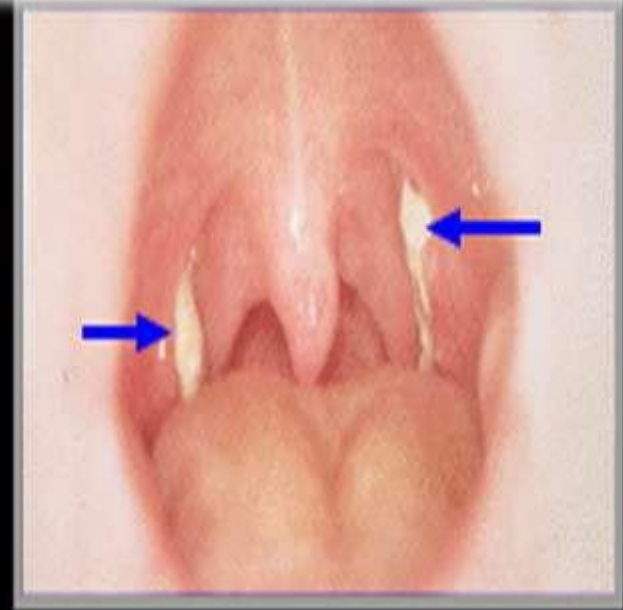

Diphtheria - notice the pseudomembrane in the posterior pharynx. It can become very large and may obstruct the airway.

Appearance of *C. diphtheria*

- *C. diphtheria* are thin Gram positive bacilli, straight or slightly curved and often enlarged (clubbing) at one or both ends and are arranged at acute angles giving shapes of Chinese letters or V shape which is characteristic of these organisms (Fig 1). Present in the body of the bacillus are numerous metachromatic granules which give the bacillus beaded or barred appearance. These granules are best demonstrated by Albert's stain.

Albert staining

- Albert stain I
 - Toluidine blue 0.15 gm
 - Malachite green 0.20 gm
 - Glacial acetic acid 1.0 ml
 - Alcohol(95%) 2.0 ml
 - Distilled water 100 ml
- Albert stain II
 - Iodine 2.0 gm
 - Potassium iodide 3.0 gm
 - Distilled water 300

Albert staining Procedure

- Cover the heat-fixed smear with Albert stain I. Let it stand for two minutes.
 - Wash with water.
 - Cover the smear with Albert stain II. Let it stand for two minutes.
 - Wash with water, blot dry and examine.

How the *C.diphtheria* appear

- To demonstrate metachromatic granules in *C.diphtheriae*. These granules appear bluish black whereas the body of bacilli appear green or bluish green.

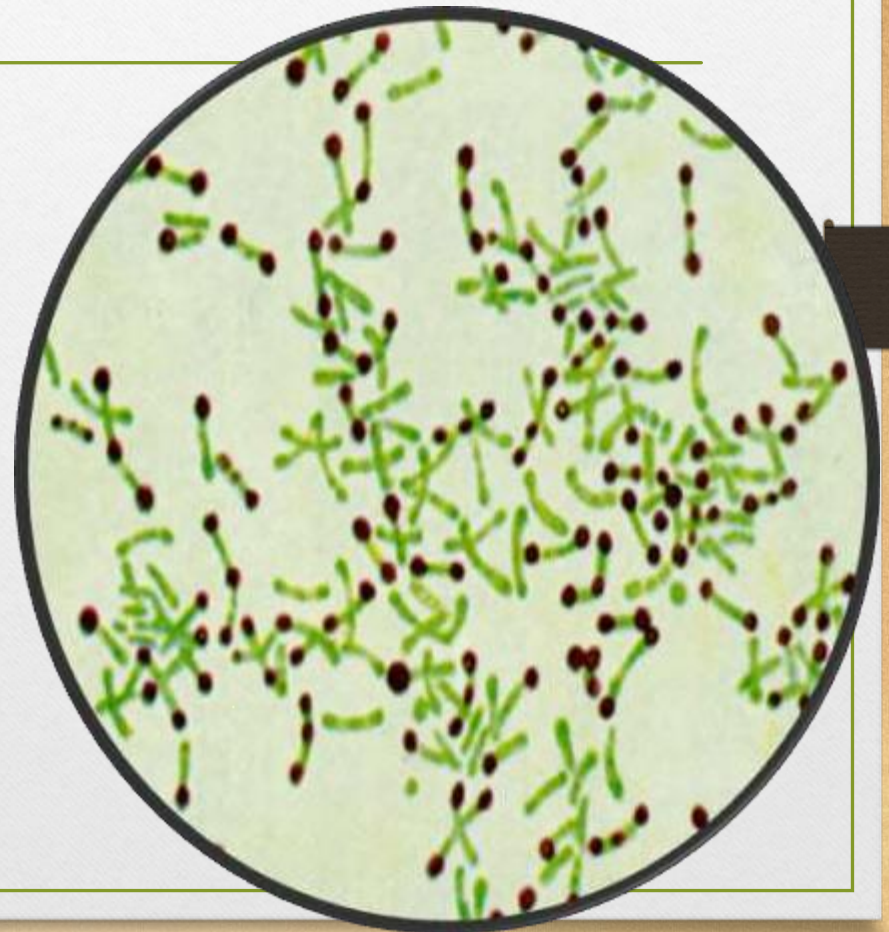

Flagellar - staining

- Flagella are usually invisible under light microscopy, but their identification and anatomy are important in determining some pathogens. Certain chemicals that bind to the flagella are used in the staining process. The flagella color may change or an increase in contrast should make them visible.



Endospore staining



- The cell walls of endospores are impermeable to most chemicals, and being in the genera *Bacillus* and *Clostridium*, cause diseases such as anthrax, tetanus and gangrene. The staining process involves both a primary stain and a counterstain.

Capsule - Staining

- A stain used to reveal negatively charged bacterial capsules. The encapsulated cells will have a halo appearance under the microscope.

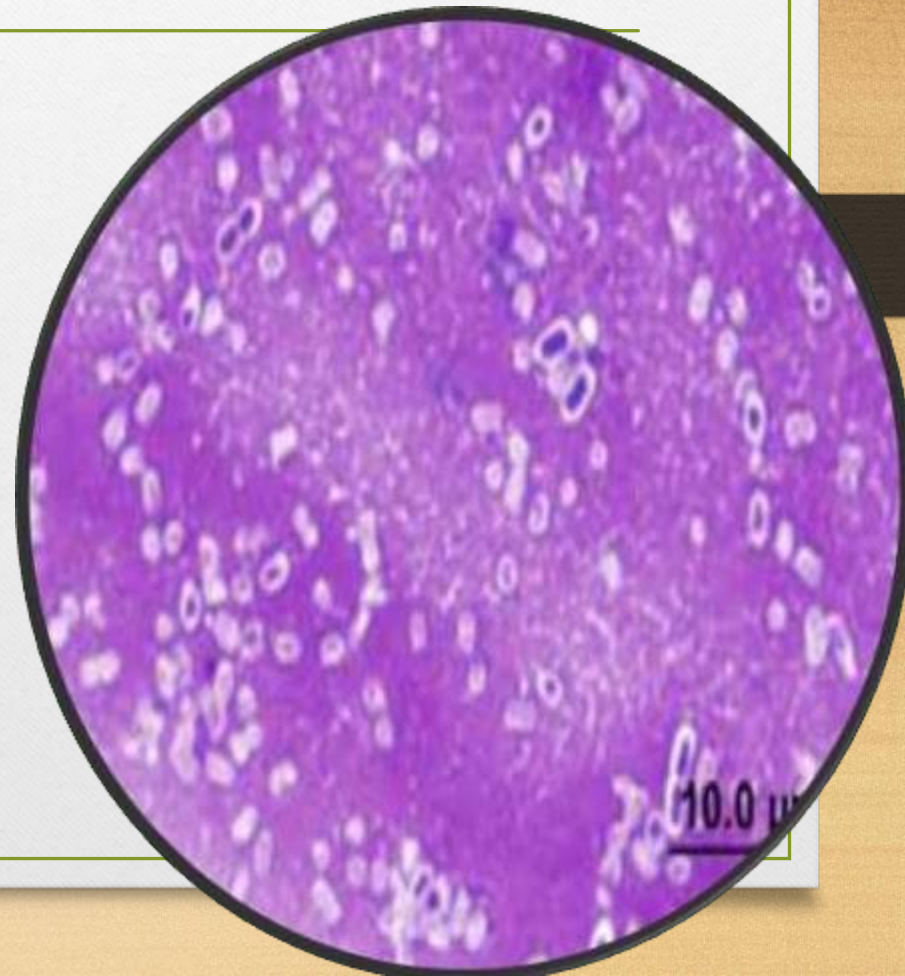

Negative staining

- India Ink, Nigrosin
- Organisms are not stained, only the background is stained
- Unstained organisms stand out in contrast
- Use: To demonstrate the capsule of *Cryptococcus neoformans*, *Streptococcus pneumoniae*



Cryptococcus Neoformans

India Ink Prep

Nigrosin used for Negative *Staining*

- The negative stain is particularly useful for determining cell size and arrangement. It can also be used to stain cells that are too delicate to be heat-fixed.

