

# **STERILIZATION**

**Deepankar Rath  
Assistant Professor  
CUTM, Rayagada**

# CONTENTS

- Introduction
- Sterilization method
- Equipment's involved in large scale sterilization
- Sterilization indicators
- Evaluation of efficiency of sterilization /Sterility testing

# INTRODUCTION

**Sterilization means killing of microbes.**

The main reasons for controlling the microorganisms are:

1. To prevent the contamination in sterile products.
2. To prevent decomposition and spoilage of food and food products.
3. To prevent contamination of unwanted microbes in pure cultures and other microbiological experiments performed for research studies.
4. To prevent unwanted microbial contamination in antibiotics, enzymes, vitamin fermentation and other industrial processes.
5. To prevent contamination in aseptic areas which are used for the preparation of sterile dosage form.

# STERILIZATION METHODS

## **1. Physical methods**

- a) Dry heat sterilization
- b) Moist heat sterilization/steam sterilization
- c) Radiation/Cold sterilization
- d) Filtration/Mechanical method

## **2. Chemical methods**

- a) Gaseous sterilization
- b) By using disinfection

# 1. PHYSICAL METHOD

## a) Dry heat sterilization

- Heat is the most reliable and rapid method of sterilization.
- The killing effect of dry heat is due to protein denaturation.
- The time required for the sterilization is inversely proportional to the temperature of exposure.
- Micro organisms are more resistant to dry heat as compared to moist heat and therefore this process requires higher temperature and longer exposure times.

## **Sunlight and drying**

- Sunlight possesses ultraviolet rays which along with the heat rays are responsible for appreciable germicidal activity.
- This is the natural method for sterilization of water in tanks, rivers and lakes.
- Spores are unaffected by drying. Hence it is very unreliable method.

## **Red hot**

- It is used to sterilize metallic objects by holding them on the flame till they are red hot. Eg : inoculating wires, needles, forceps etc.

## **Flaming**

- The article is passed over the flame without allowing it to become red hot. Eg: mouth of culture tube, glass slides, needles, coverslips etc.

## **b) Moist heat sterilization**

- Sterilization by moist heat means killing of microorganisms with hot air or steam. The lethal effect of moist heat is due to denaturation and coagulation of proteins.
- Moist heat sterilization is divided into three forms.
  1. Temperature below 100°C
  2. Temperature at 100°C
  3. Temperature above 100°C

## **1. Temperature below 100°C:**

- Heat liable fluids may be disinfected by heating at temperature below 100°C.

## **2. Temperature at 100°C:**

- Boiling at 100°C for 10 to 30 minutes kills all vegetative bacteria and some bacterial spores.

## **3. Temperature above 100°C:**

- Saturated steam is a more efficient sterilizing agent.eg: Autoclave.



## **C) Radiation/Cold sterilization:**

- Use of ultra-violet rays.
- Ionising radiations: X-rays, gamma rays, beta-rays

## **D) Filtration/Mechanical Method**

- This is a non thermal method of sterilization used widely in pharmaceutical industries where heat labile solutions are to be sterilized.
- The following types of filters have been used for sterilization
  1. Asbestos filter ( seitz filter)
  2. Sintered glass filter (Morton filter)
  3. Filter candles (ceramic filter)
  4. Membrane filter (Millipore/ultra filter)

## **2. CHEMICAL METHOD**

### **a. Gaseous sterilization:**

Eg: Formaldehyde, Ethylene oxide etc.

### **b. By using disinfectants**

Eg: Cresol, phenol etc.

# EQUIPMENT'S INVOLVED IN LARGE SCALE STERILIZATION

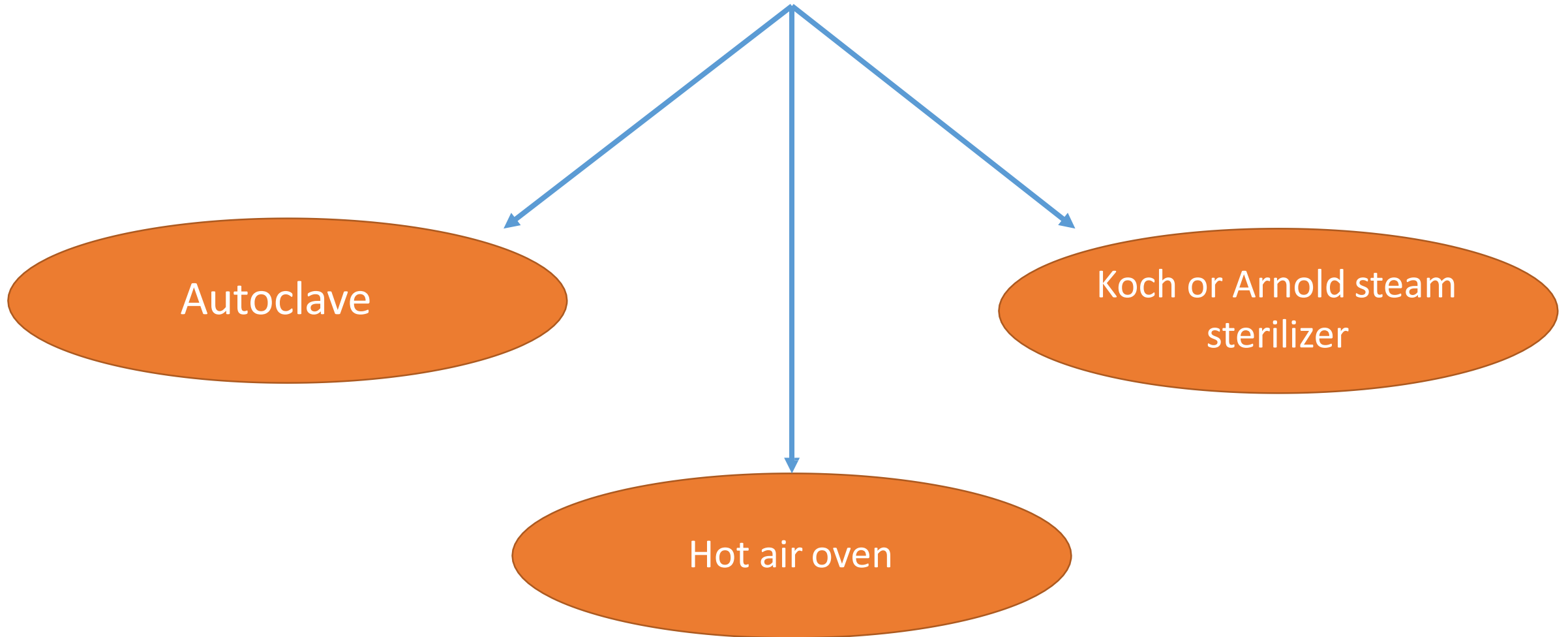

# 1. AUTOCLAVE

- The laboratory autoclave or pressure cooker type autoclave consist of a vertical or horizontal cylinder of gun metal or stainless steel in a supporting frame or case.
- The autoclave lid is provided with pressure gauge.
- The autoclave is provided with control for adjusting the pressure and temperature and a safety valve to avoid explosions.
- Water is added on the bottom of the autoclave and the articles to be sterilized are placed in a perforated shelf.
- The lid is closed, discharge tap is opened and safety valve is adjusted to the required pressure.

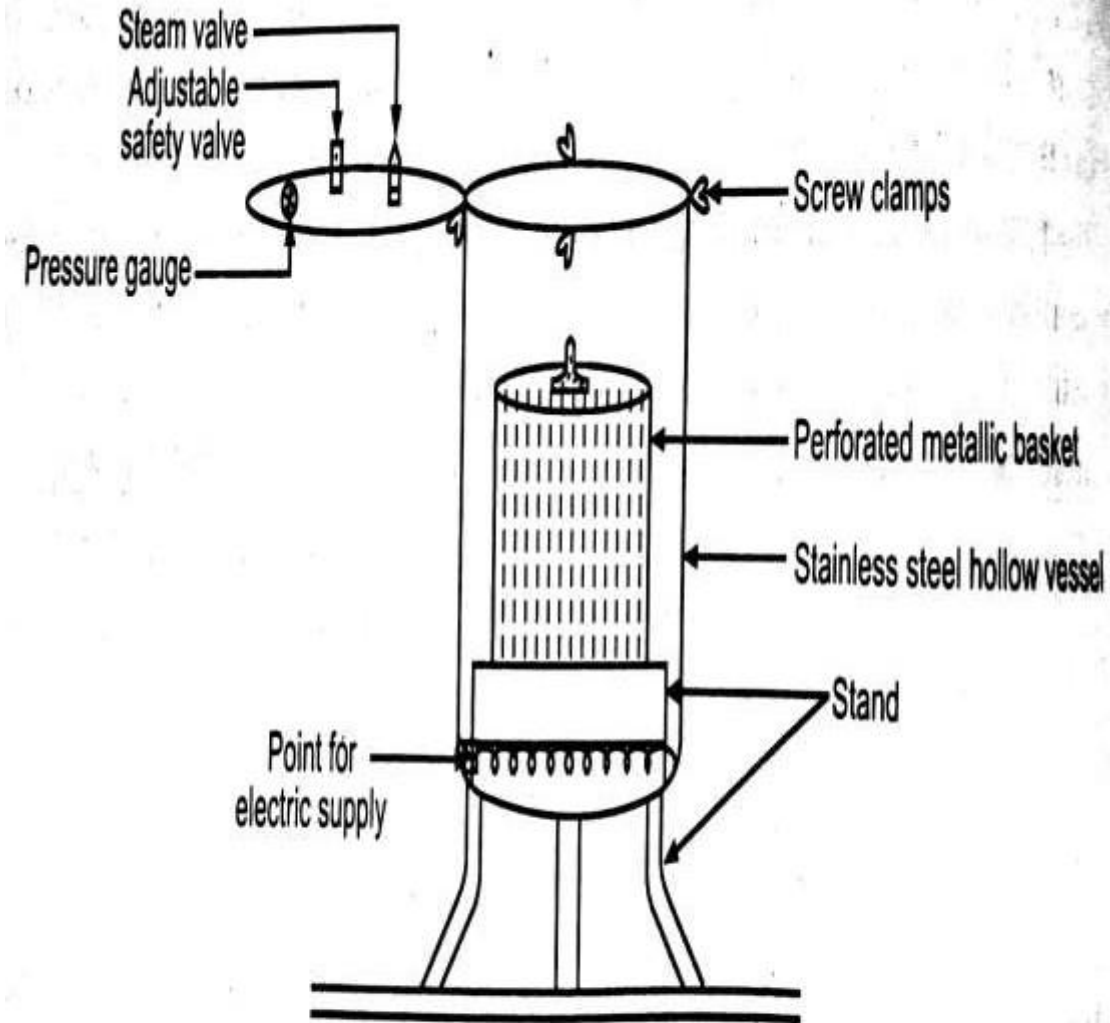
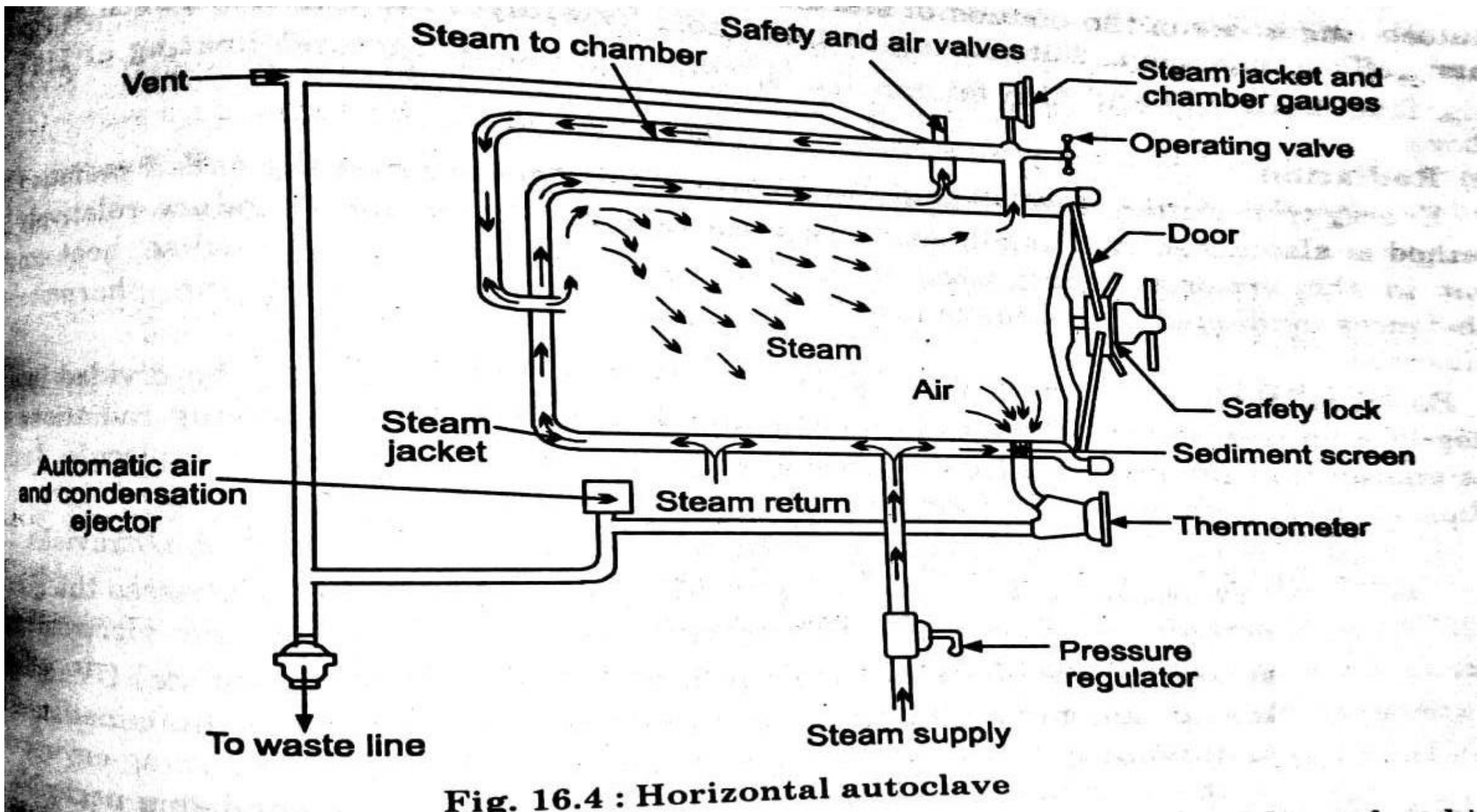

Fig. 16.3 : Vertical autoclave



**Fig. 16.4 : Horizontal autoclave**

# AUTOCLAVE CONDITIONS (TEMPERATURE/TIME/PRESSURE RELATIONSHIP)

| Temperature <sup>0</sup> C | Steam pressure(lb/sq.inch) | Holding time (minutes) |
|----------------------------|----------------------------|------------------------|
| 115-118                    | 10                         | 30                     |
| 121-124                    | 15                         | 15                     |
| 126-129                    | 20                         | 10                     |
| 135-138                    | 30                         | 3                      |

# ADVANTAGES

- Microorganisms are destroyed more efficiently than the dry heat because of the greater penetration power of the steam under pressure.
- The method is applicable to the wide variety of materials and for large load.
- Spores are easily destroyed by moist heat sterilization.

# DISADVANTAGES

- During autoclaving the pH of aqueous solution gets changed due to water loss.
- Oils do not get sterilized in autoclave as they are hydrophobic in nature and they don't allow steam to penetrate them.
- Autoclave sterilization is not used for thermolabile substances, powders and plastic that melts.



# APPLICATIONS

- To sterilize aqueous solution, saline solution, bacteriological media like nutrient broth etc.
- To sterilize surgical dressings, rubber gloves, plastic fabrics and surgical instruments.
- Sterilize different glassware like pipettes, petri plates, flasks and different metal instruments.

## 2. HOT AIR OVEN

- This is the most widely used method of sterilization by dry heat.
- The hot air oven consist of a doubled walled chamber of aluminium or stainless steel separated from the outer case by a thick layer of insulation made of fibre glass.
- An oven is based on the principle where sterilization is accomplished by dry heat or hot heat.
- Dry heat is less effective as compered to moist heat because in the presence of moisture, proteins are easily coagulated and moist heat has greater penetration power than the dry heat.
- By the process of denaturation and oxidation, microbes are destroyed by dry heat.

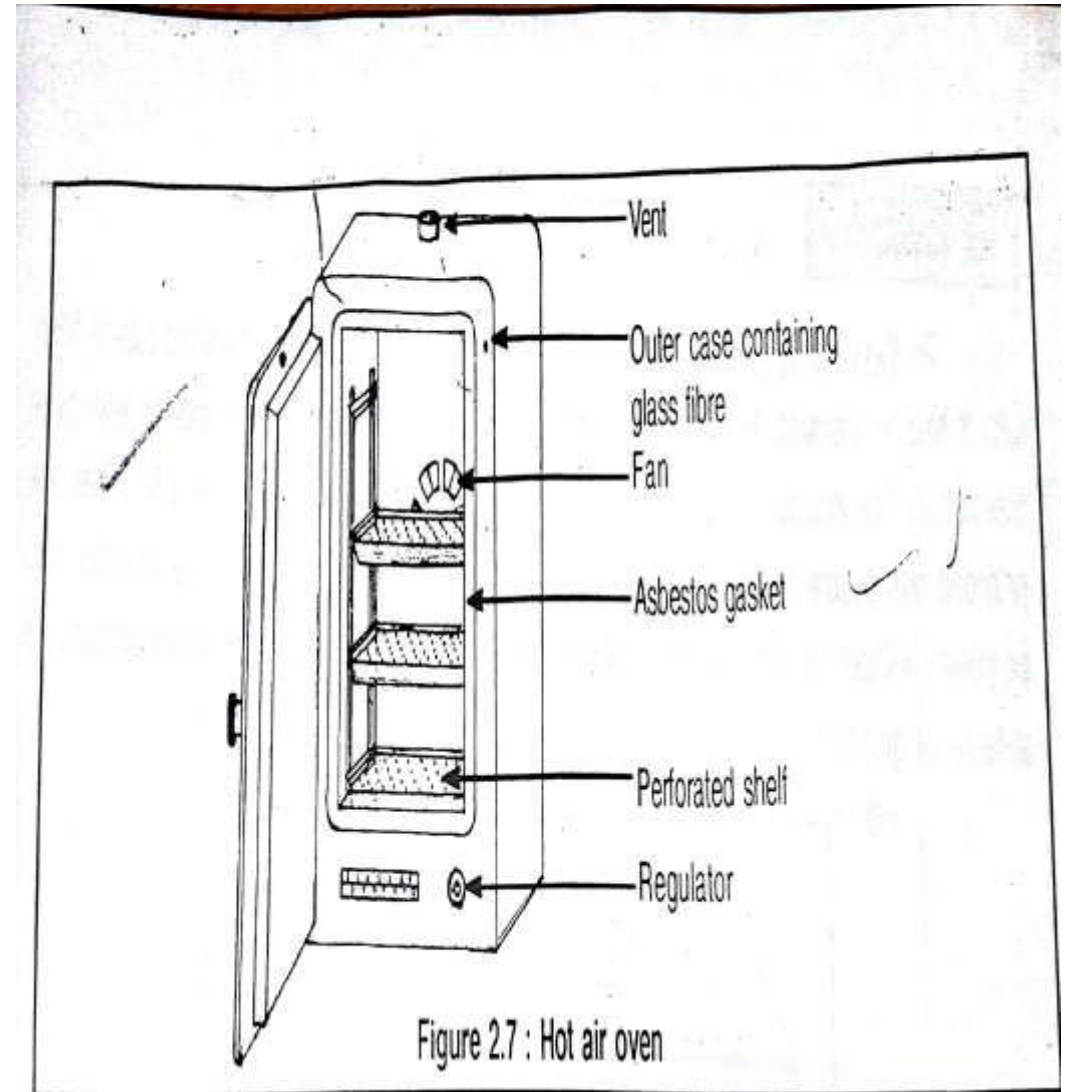

# TEMPERATURE-TIME RELATIONSHIP FOR HOT AIR OVEN

- Substances that are not heat-labile and can tolerate temperature upto 250°C may be sterilized by hot air oven.
- For normal sterilization work, the oven should be operated at 160°C for 2 hours.

| Temperature (°C) | Time (hr) |
|------------------|-----------|
| 140              | 3         |
| 150              | 2.5       |
| 160              | 2         |
| 170              | 1         |
| 180              | 0.5       |

# APPLICATION

- Hot air oven is used to sterilize glassware, forceps, scissors, syringes, petri-dishes, test tubes, pipettes etc.
- Hot air oven is used for sterilization of fixed oils, powders, glycerin, liquid paraffin, propylene glycol, waxes and other articles that are either spoiled or not effectively sterilized by the moist heat.

### 3. KOCH OR ARNOLD STEAM STERILIZER

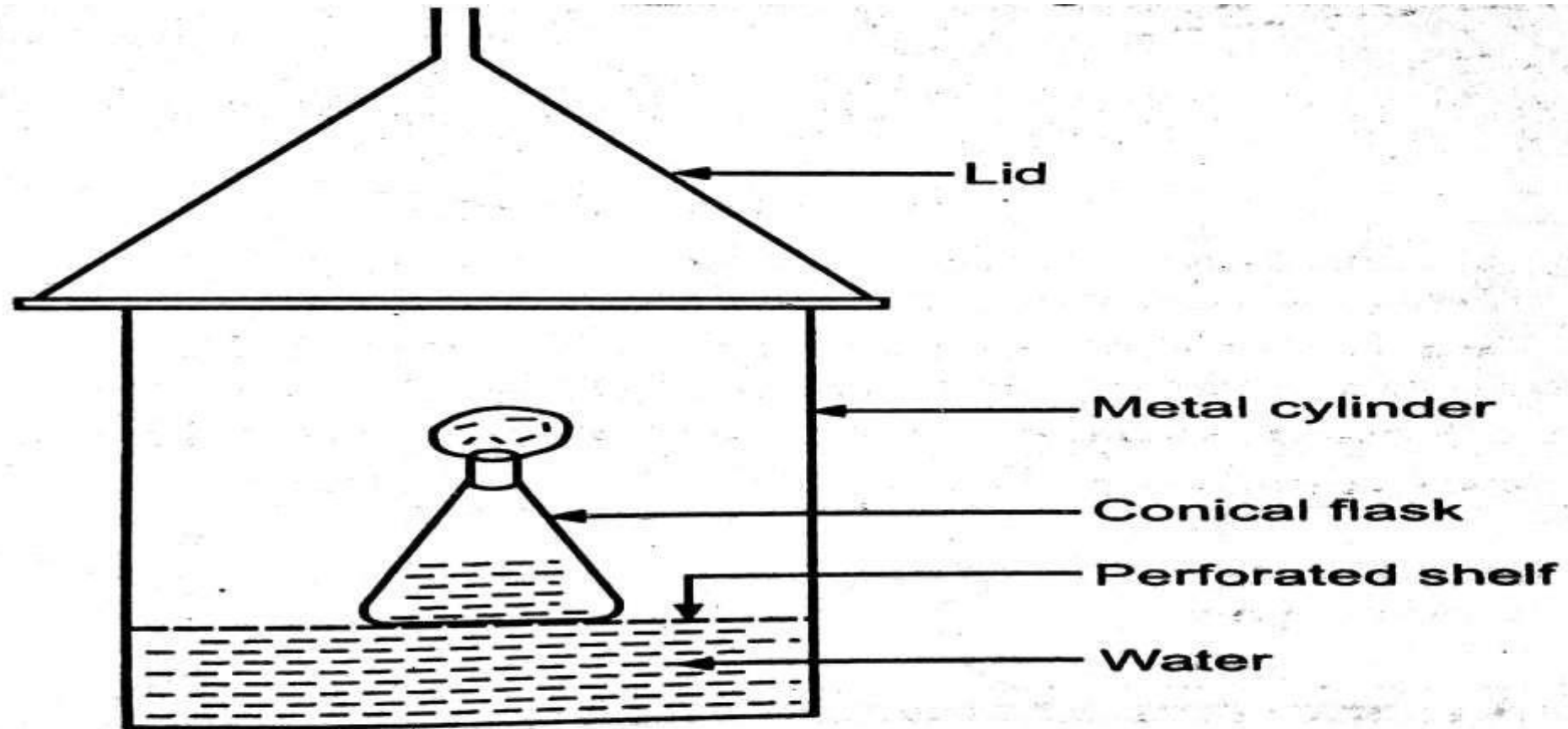

**Fig. 16.2 : Steam sterilizer**

### 3. KOCH OR ARNOLD STEAM STERILIZER

- A Koch or Arnold steam sterilizer is usually used in industries.
- This steam sterilizer consists of a vertical metal cylinder with removable conical lid having a small opening for the escaping steam.
- Water is added on the bottom and a perforated shelf above the water level is present.
- Single exposure to steam for 90 minutes ensures complete sterilization but media containing sugar and gelatin, which may get decomposed on long heating. Hence such materials may be exposed at 100°C for 20 minutes on three successive days. This is known as **tyndallisation or intermittent or fractional sterilization**.
- First exposure to steam kills all vegetative bacteria and at second exposure all spores germinate in a favourable medium and are killed on subsequent occasions.

# EVALUATION OF EFFICIENCY OF STERILIZATION / STERILITY TESTING

Sterility tests can be carried out using following methods.

1. Method A: **Membrane filtration.**
2. Method B: **Direct Inoculation.**

# MEMBRANE FILTRATION

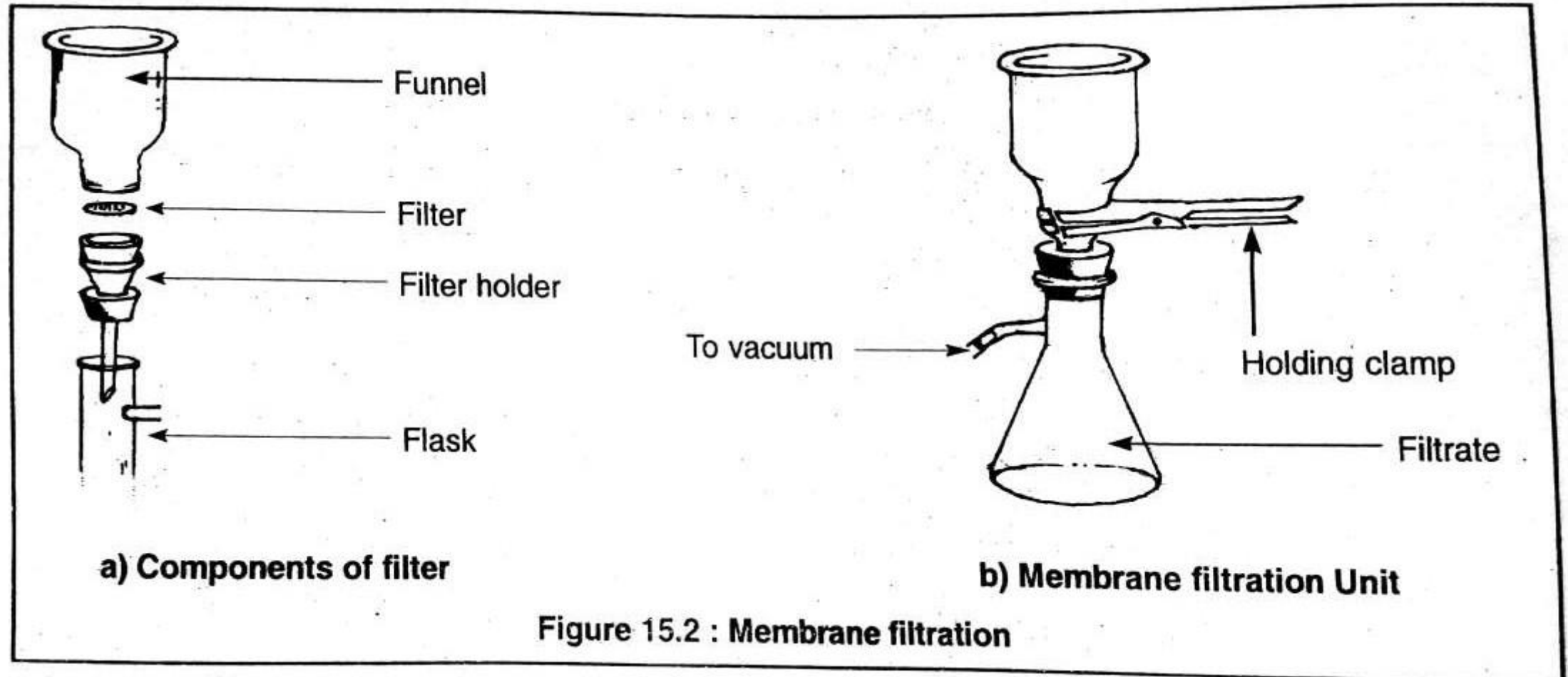

Figure 15.2 : Membrane filtration



# MEMBRANE FILTRATION

- First clean the membrane filter unit and sterilize the unit and membrane filter separately by moist heat sterilization (Autoclave).
- Transfer the unit on laminar air flow bench or aseptic area and place the membrane filter in the unit as shown in fig.
- Pass all the solution through filter under vacuum.
- After filtration, the membrane is removed aseptically and cut into two parts using sterile scissors.
- One half part of membrane filter is placed in 100ml of fluid thioglycollate medium (FTM) and incubate at 30-35<sup>0</sup>C for not less than 7 days.
- Other half part of membrane filter is placed in soyabean casein digest medium (SCDM) and incubate at 20-25<sup>0</sup>C for not less than 7 days.

# MEMBRANE FILTRATION

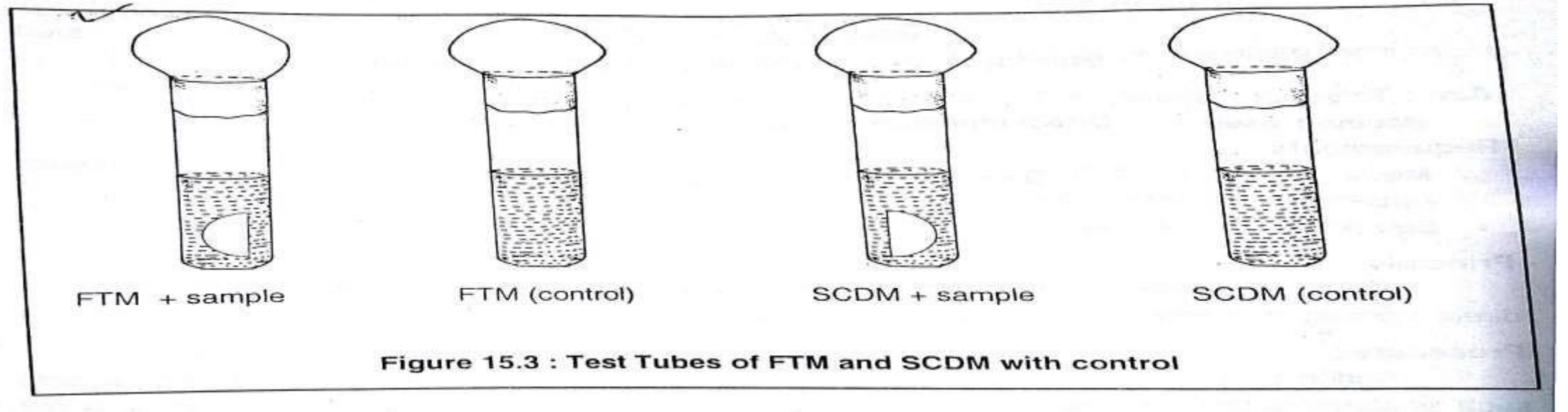

Observe the turbidity in the medium by comparing with the standard tube. If it has no turbidity in fluid thioglycollate medium and soyabean casein digest medium means it is free from microorganisms and suitable for use.

# DIRECT INOCULATION

- Cotton or prefilled syringe is transferred directly to culture media using sterile instruments such as sterile forceps.
- Incubate sample containing fluid thioglycollate medium (FTM) at 30-35°C for not less than 7 days and soyabean casein digest medium (SCDM) at 20-25°C for not less than 7 days.

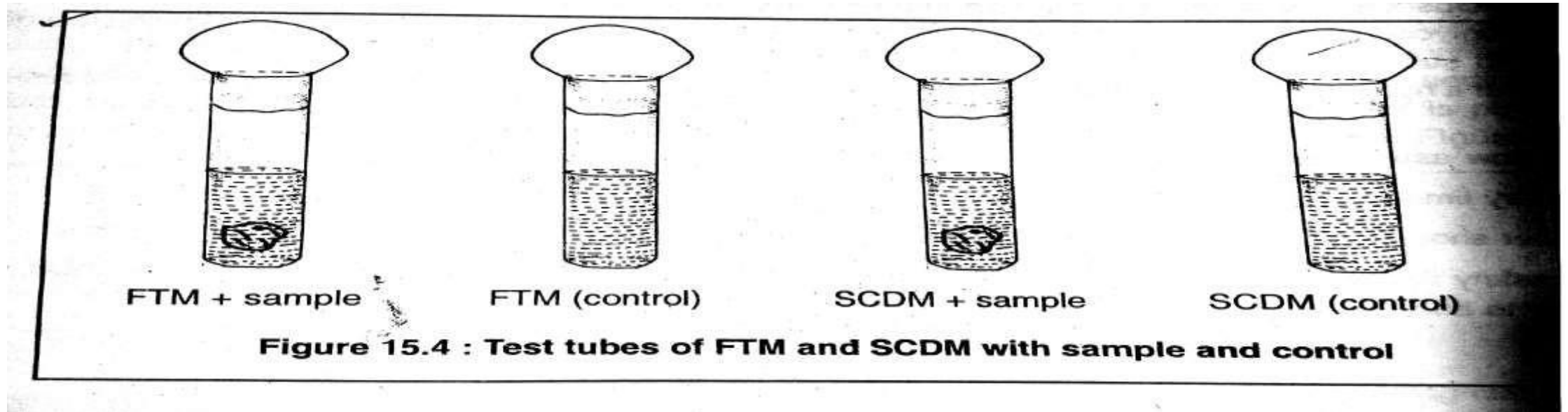

Observe the turbidity in the medium by comparing with the standard tube. If it has no turbidity in fluid thioglycollate medium and soyabean casein digest medium means it is free from microorganisms and suitable for use.