

Filtration devices for management of water quality in aquariculture

Dr. Mangesh M. Bhosale
Asst. Professor, Aquaculture
SoF, CUTM, Odisha
mangeshcof@gmail.com.

Principle of Filtration

Aeration



Removal of particulate matter



Biological filtration to remove waste ammonia and nitrite



Buffering of pH.

WATER TREATMENT PROCESS

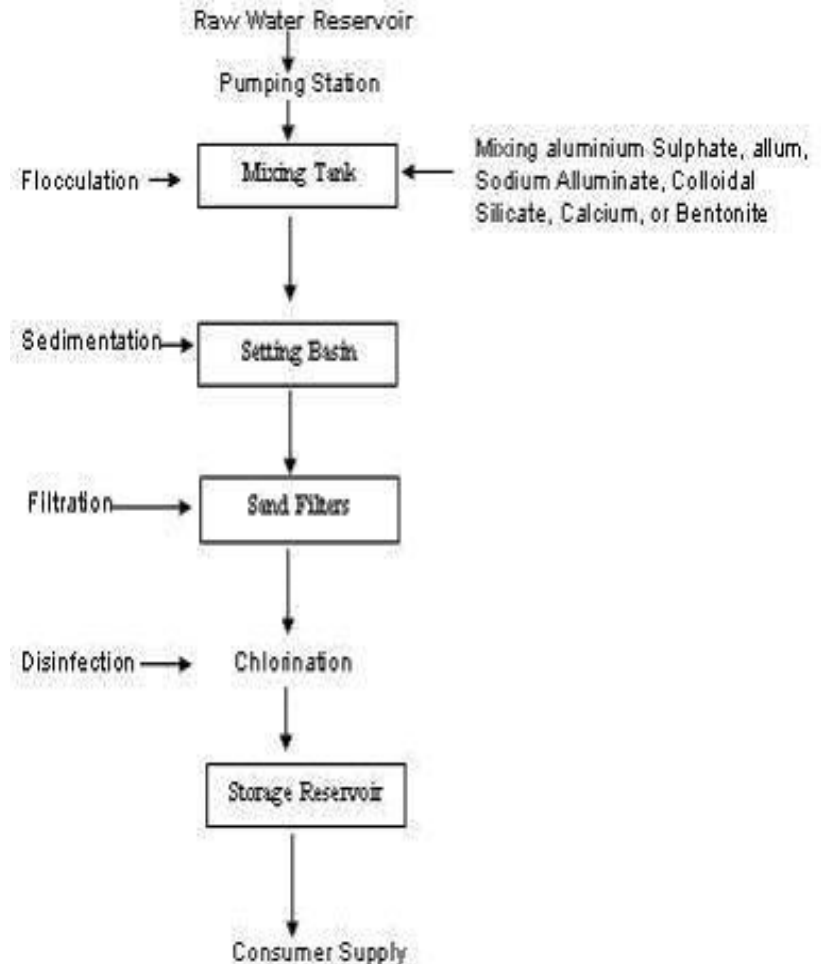
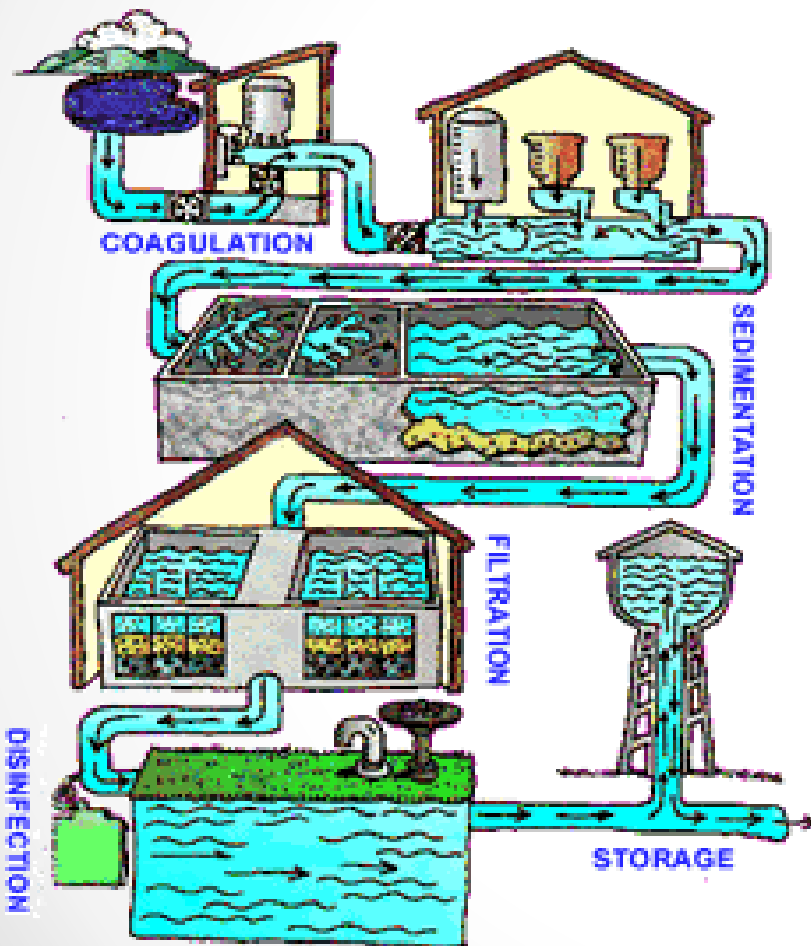

FILTRATION OF WATER

“In order to remove the contents of impurities still further, the water is filtered through the beds of fine granular material like sand and foam”

THEORY OF FILTRATION:

- Mechanical straining
- Sedimentation
- Biological metabolism
- Electrolytic changes

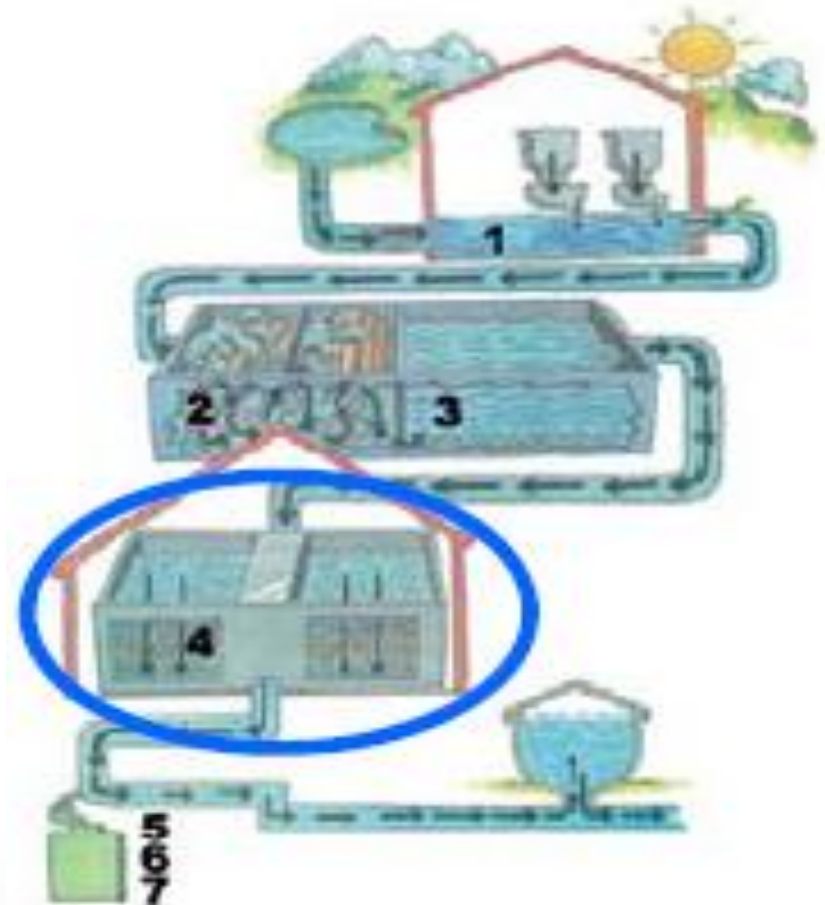

FILTER SAND

Filter sand is classified on the basis of effective size and uniformity coefficient.

- The effective size is the size of sieve through which 10% of the sample of sand by weight will pass.
- Uniformity coefficient: $\text{sieve size} / \text{effective size}$

CLASSIFICATION OF FILTERS:

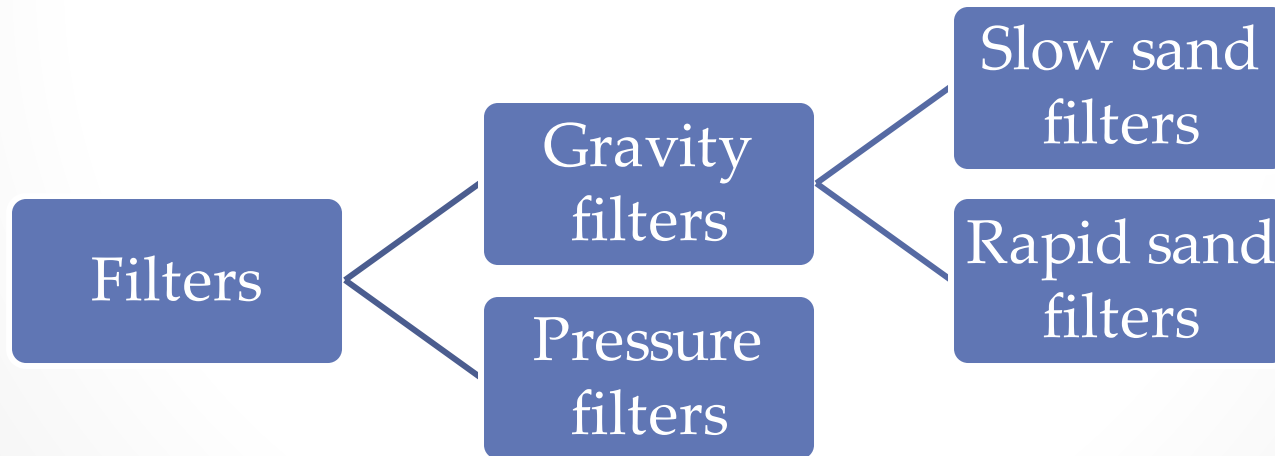

SLOW SAND FILTERS

Purpose:

The water is allowed to pass slowly through a layer of sand placed above the base material and thus the purification process aims at simultaneously improving the biological, chemical, and physical characteristics of water.

Slow Sand Filtration

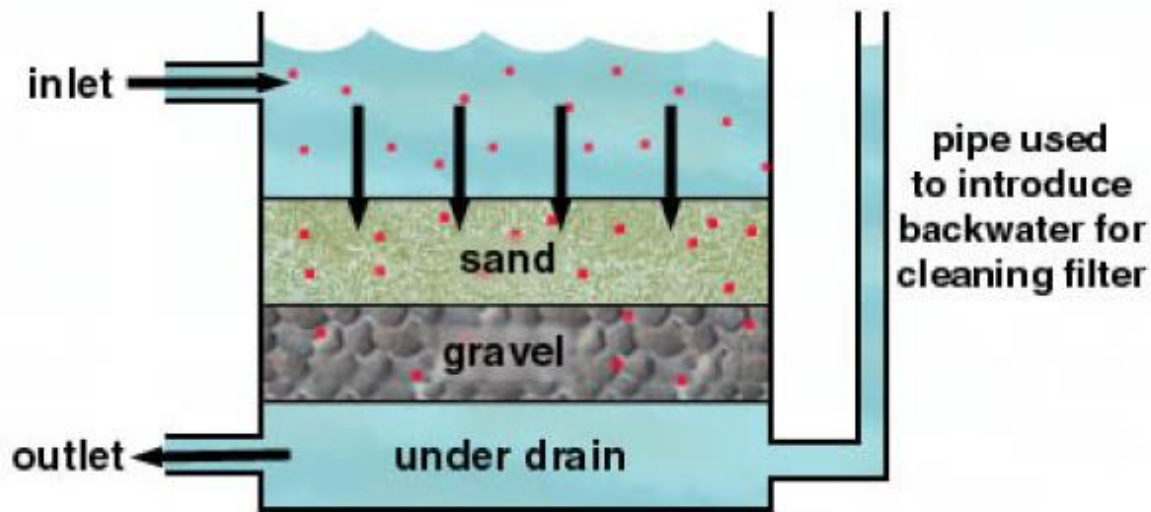

Essential parts:

- Enclosure tank:
 - stone masonry/brick masonry
 - waterproof material
 - bed slope is 1 in 100 to 1 in 200
 - depth of the tank is 2.5 to 3.5 m

Under-drainage system:

Central drain

Lateral drain

Lateral drain:

- Placed at a distance of about 2.5 to 3.5 m.
- Stopped at a distance of 500 mm to 800 mm from walls of the tank.
- Open joint pipes

Base material:

- Placed on top of the under-drainage system
- Varies from 300 mm to 700 mm depth
- Graded and laid in layers of 150 mm

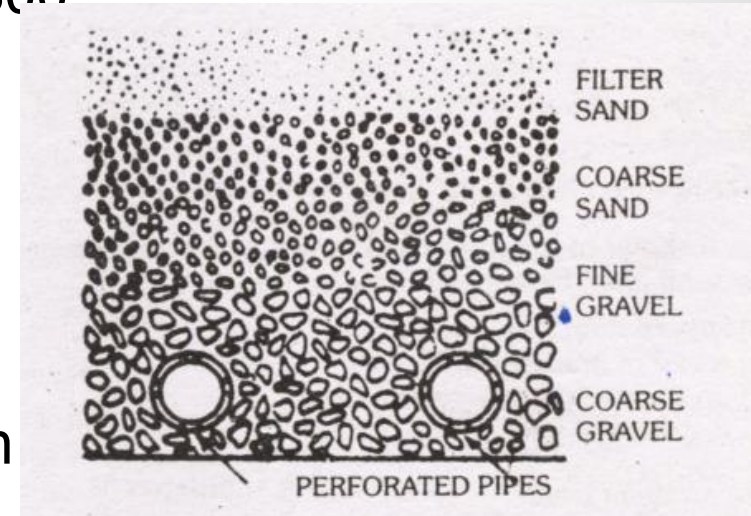

LAYER	DEPTH OF LAYER	SIZE OF GRAVEL
Topmost	150mm	3mm- 6mm
Intermediate	150mm	6mm- 20mm
	150mm	20mm- 40mm
Lowest	150mm	40mm- 65mm
Total	600mm depth	

Working:

- The water is allowed to enter the filter through the inlet chamber.
- It descends through the filter media and during this process, it gets purified.
- These filters are usually worked for a maximum filtration head of 750 mm.

Rate of filtration

100 to 200 liters per hour per m² of filter area

Efficiency

Bacterial load: 99.50 to 99.9% is removed

Turbidity

Remove turbidity of 50 ppm

Cleaning

Top layer of the sand is removed to a depth of 15 to 25 mm

Effective depth of filter media is reduced

Fresh layer of 150mm depth of graded sand is added

Colour

Less efficient in removal of colour (20-25%)

RAPID SAND FILTER OF GRAVITY TYPE

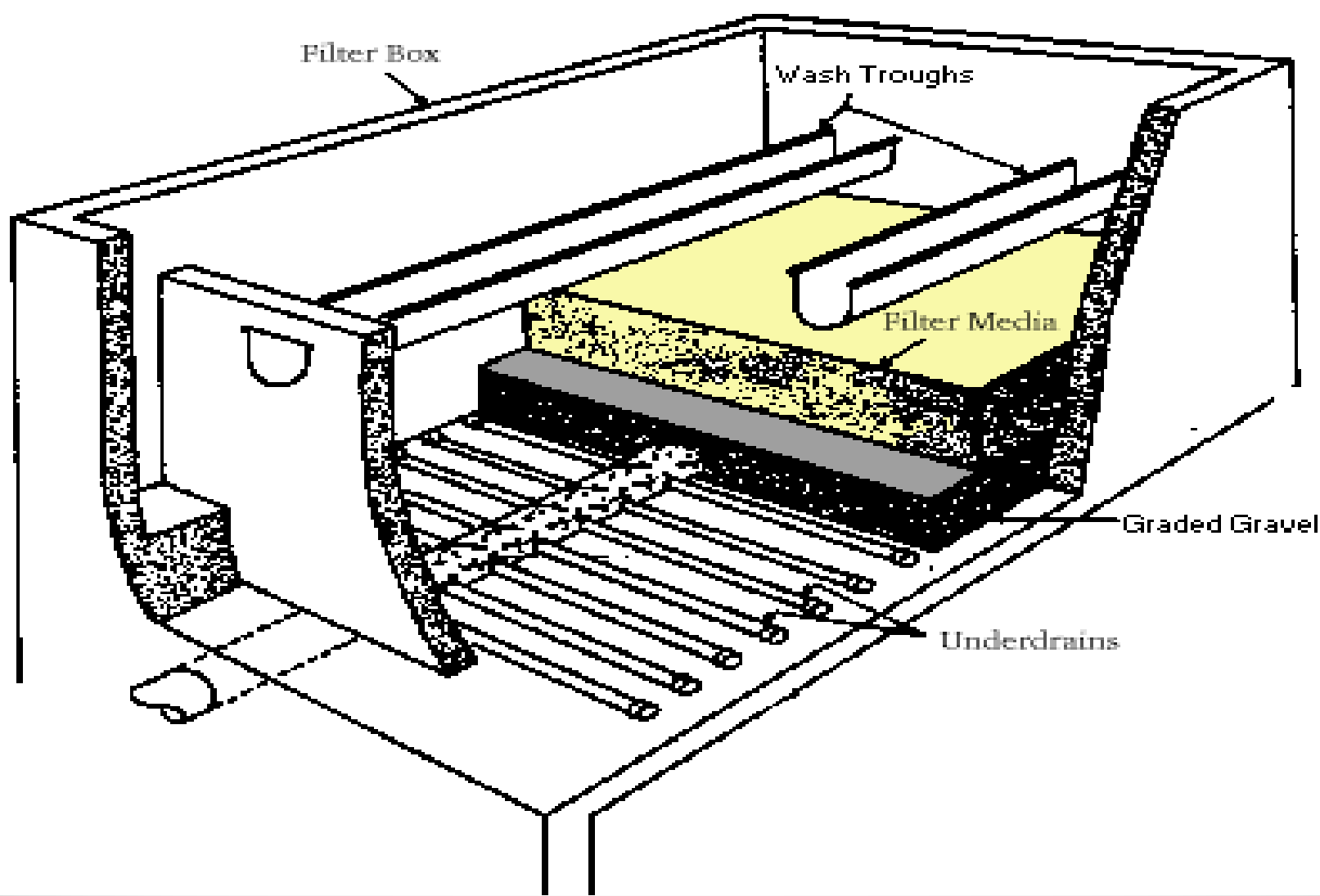

Layout of typical rapid sand filter (gravity type)

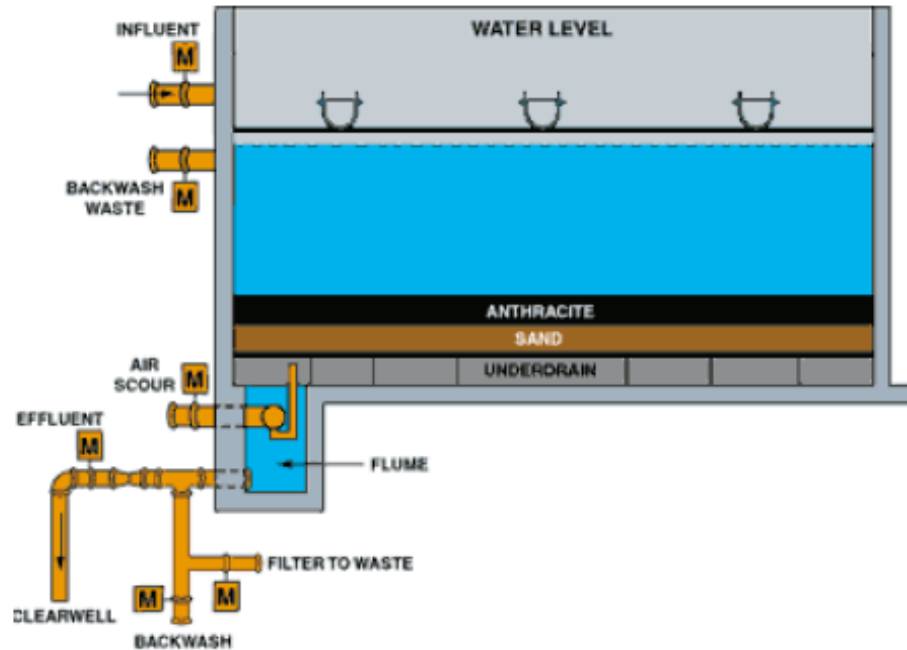

Advantages:

1. Rapid sand filter can deal with raw water directly
2. No preliminary storage is needed
3. The filter beds occupy less space
4. Filtration is rapid, 40 – 50 times that of a slow sand filter
5. The washing of the filter is easy
6. There is more flexibility in operation

Filter media of sand:

- Filtering medium: sand (effective size of sand particles 0.4-0.7 mm, coarse sand)
- Depth of sand bed: 1-1.5 feet deep
- Clogging of filters by suspended impurities and bacteria: Loss of Head
- Cleaning by back-washing daily or weekly for 15 minutes

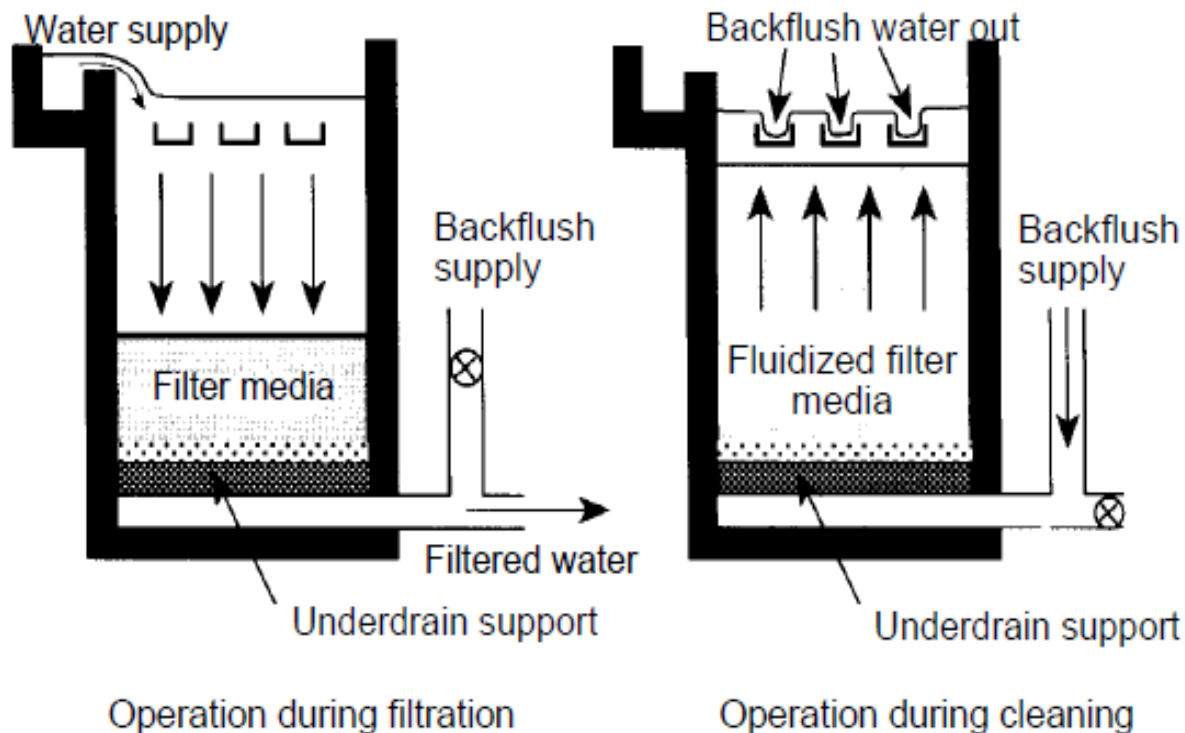

COMPARISON OF RAPID & SLOW SAND FILTERS

Properties	Rapid sand filter	Slow sand filter
Area	Small area	Large area
Rate of filtration(L/hr)	4000-7500	100-400
Sand size (diameter)	0.4-0.7 mm	0.2-0.3 mm
Pretreatment	Coagulation and sedimentation	Sedimentation
Filter cleaning	Backwashing	Scraping
Operation	More skilled	Less skilled
Removal of colour	Good	Better
Removal of bacteria	98-99%	99.9%-99.99%
Prior water storage	Storage needed	No need

PRESSURE FILTERS

“Filter is enclosed in space and the water passes under pressure greater than atmospheric pressure”

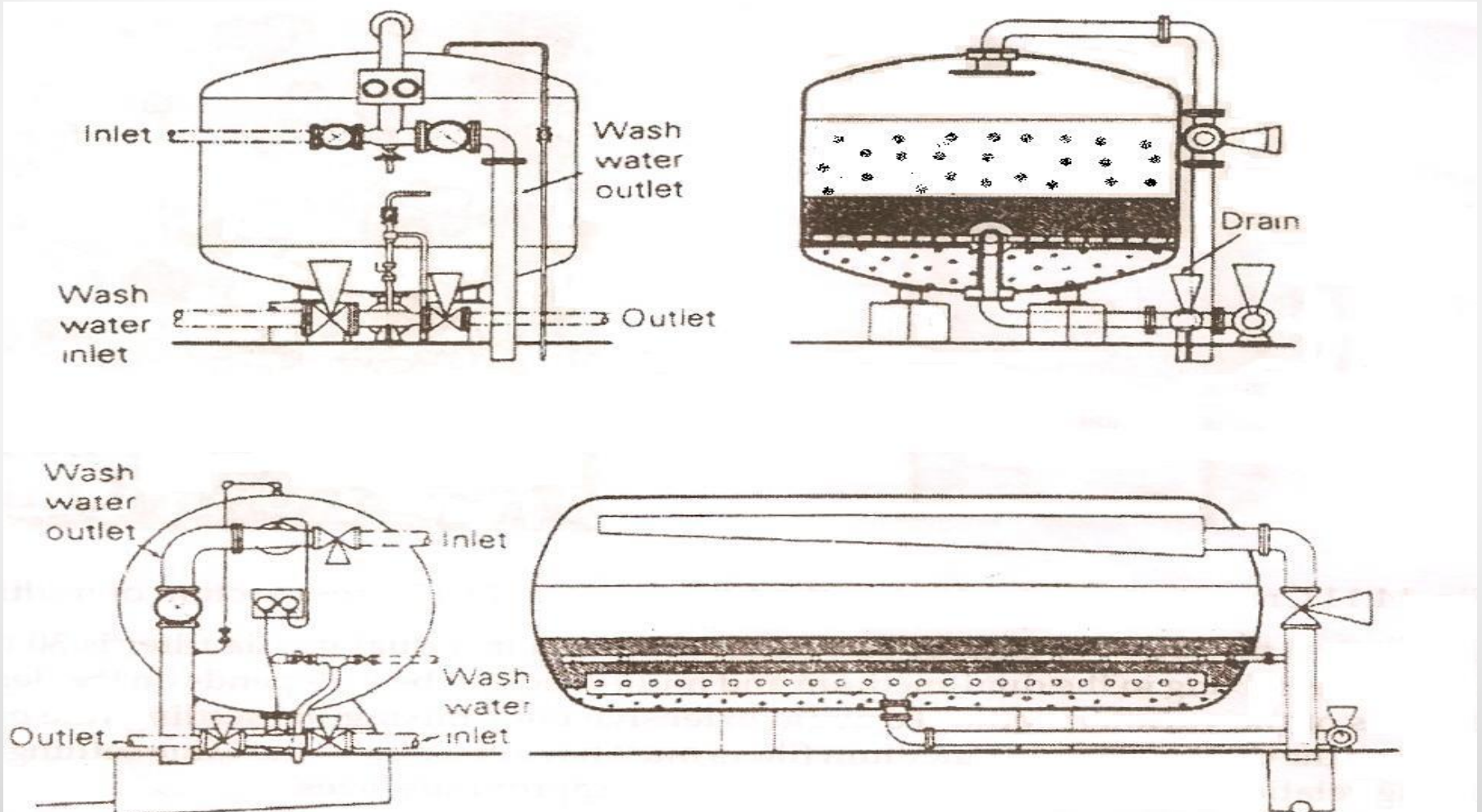

Pressure filters. Top: Vertical pressure filter, Bottom: Horizontal pressure filter

Construction:

- Closed steel cylinders.
- Diameter varies from 1.5 to 3.0 m.
- Length or height varies from 3.5 to 8.0m.
- Manholes are provided at the top for inspection.

Working:

- The water mixed with coagulant is directly admitted to the pressure filter.
- In working condition all valves are closed except those for raw water and filtered water.

Cleaning

- The compressed air may be used to agitate sand grains.
- Valves for wash water and wash water drain are opened during washing.

Rate of filtration: **6000-15000litres/hr/sq.m.**

Efficiency: **Less efficient than the rapid sand filters.**



Cleaning:

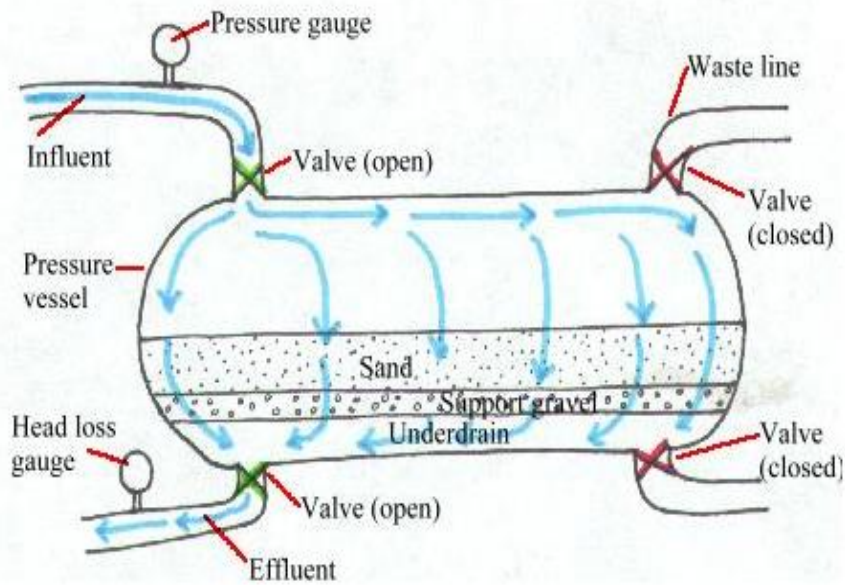

Water passing through a pressure filter in the normal direction.

Backwashing

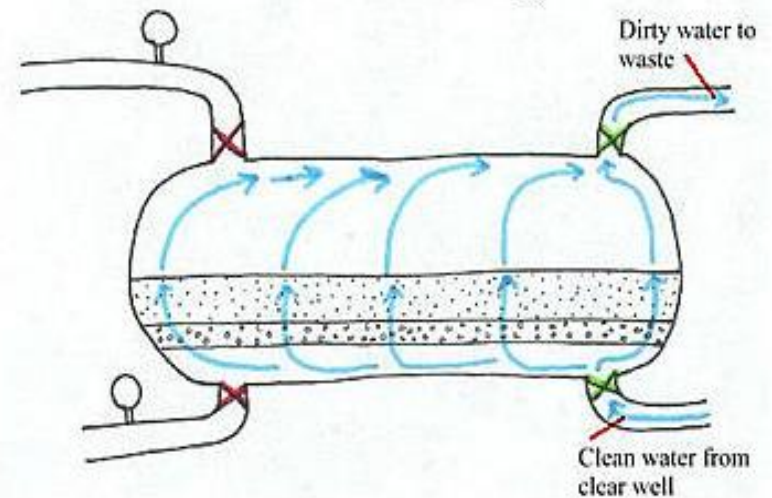

Water passing through a pressure filter in the reverse direction.

BIOLOGICAL FILTRATION

- In biological filters, bacteria are used to convert ammonia in various steps.
 1. Conversion of ammonium to Nitrite
 2. Conversion of Nitrite to Nitrate and
 3. Conversion of nitrate to molecular nitrogen.

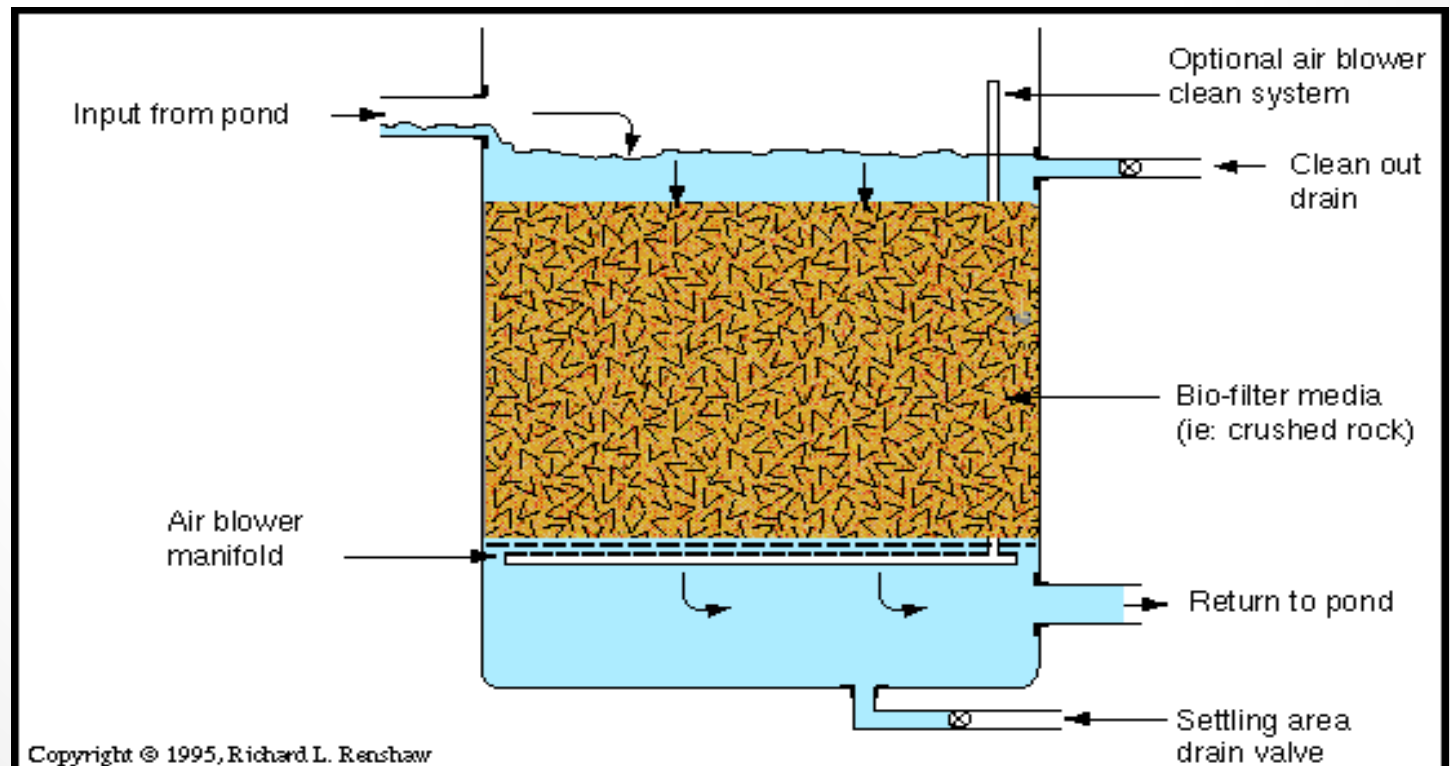

Ultraviolet Light

- UV light is electromagnetic radiation with a wavelength of 1-40nm located at lower end of the visible spectrum and beyond.
- The ability of UV light to inactivate and destroy microorganisms varies with both wavelength and the microorganisms to be inactivated.
- The most effective wavelength for disinfection is 250 – 270nm. UV light damages the genetic materials in the microorganisms which results in their inactivation and death.

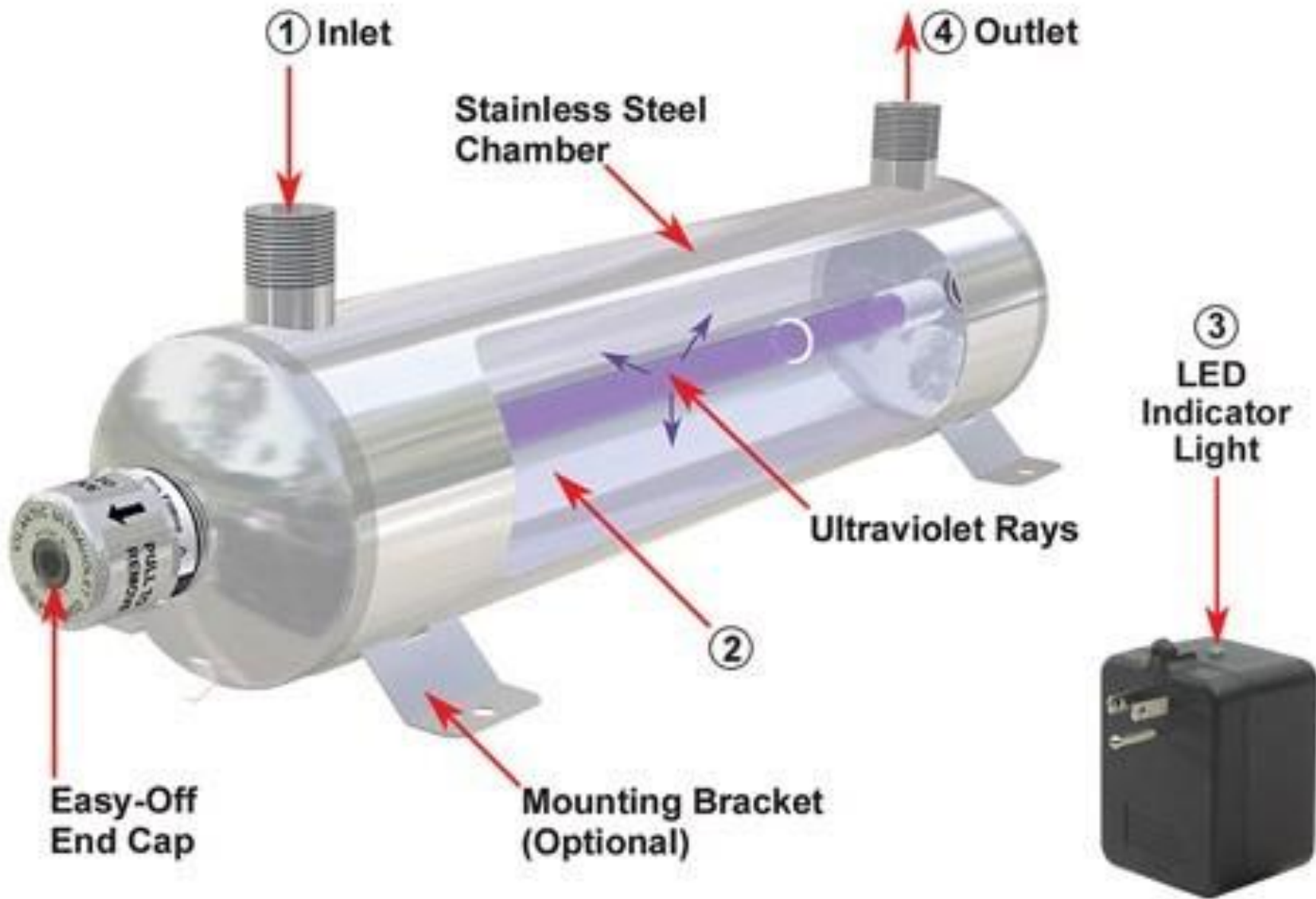

*These processes help the sanity of public health but it is up to people to make consciousness of the importance of **avoiding contamination** and pollution of our water streams. These processes cost more money day by day as water pollution increases.*

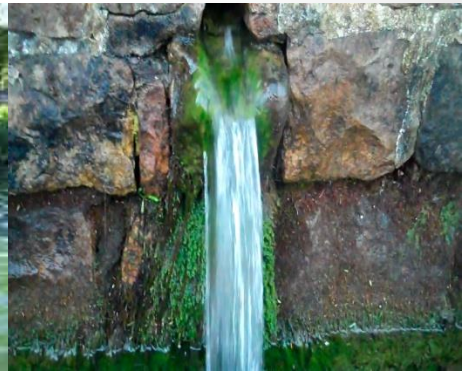

AQUARIUM FILTERS

- **Corner Filter**

- Water is forced through it.
- Composed of filter floss or other media.
- A physical/mechanical filter.
- Beneficial bacteria settle on the medium and provided biological filtration.
- Inexpensive filter for tank.
- Have a working biological and mechanical filter for your hospital tank with incorporation of Nitrobacter.



Canister Filter

- An enhanced corner filter.
- A closed box where water is forced through filtration media (mechanical and/or chemical).
- It can be placed inside the aquarium, or outside (underneath the aquarium or as hang on type).
- The canister filter has the most powerful mechanical filtration system.
- It requires frequent cleaning.
- Bacteria may also settle in this filter type.
- Biological filtration can be improved, by placing wet dry wheels at the outflow of the canister filter.
-



Power Filter

- The very easy to maintain power filter hangs on the back of the aquarium (easy access).
- Water is pulled through a mechanical filtration, using floss and insert cartridges.
- Provide enough space for chemical filtration media.



Sponge Filter

- A sponge filter looks like a tube with a sponge like material inside.
- Water flows through, bacteria will colonize the porous foam and establish a biological filtration.
- Also serve as mechanical filter by removing larger particles.



Undergravel Filter

- UGF is a perforated plate below the gravel from where water is pumped upward through the gravel by air bubbles, water stream, or a combination of both.
- This allows bacteria to colonize on gravel aiding for biological filtration.
- It does not remove larger waste particles but are inexpensive.
- Can be combined with a power head as a pre-filter for larger particles.



Fluidized Bed Filter

- Sand is used as a bacteria settlement media placed in a tube.
- The water is pumped upwards through the sand, allowing bacteria to settle within.
- Additional tubes can be used as pre-filters (mechanical) and also for chemical filters using activated carbon.
- This filter provides a large surface for bacteria colonies, but sometimes lacks in providing enough oxygen for their performance.



Queries..??

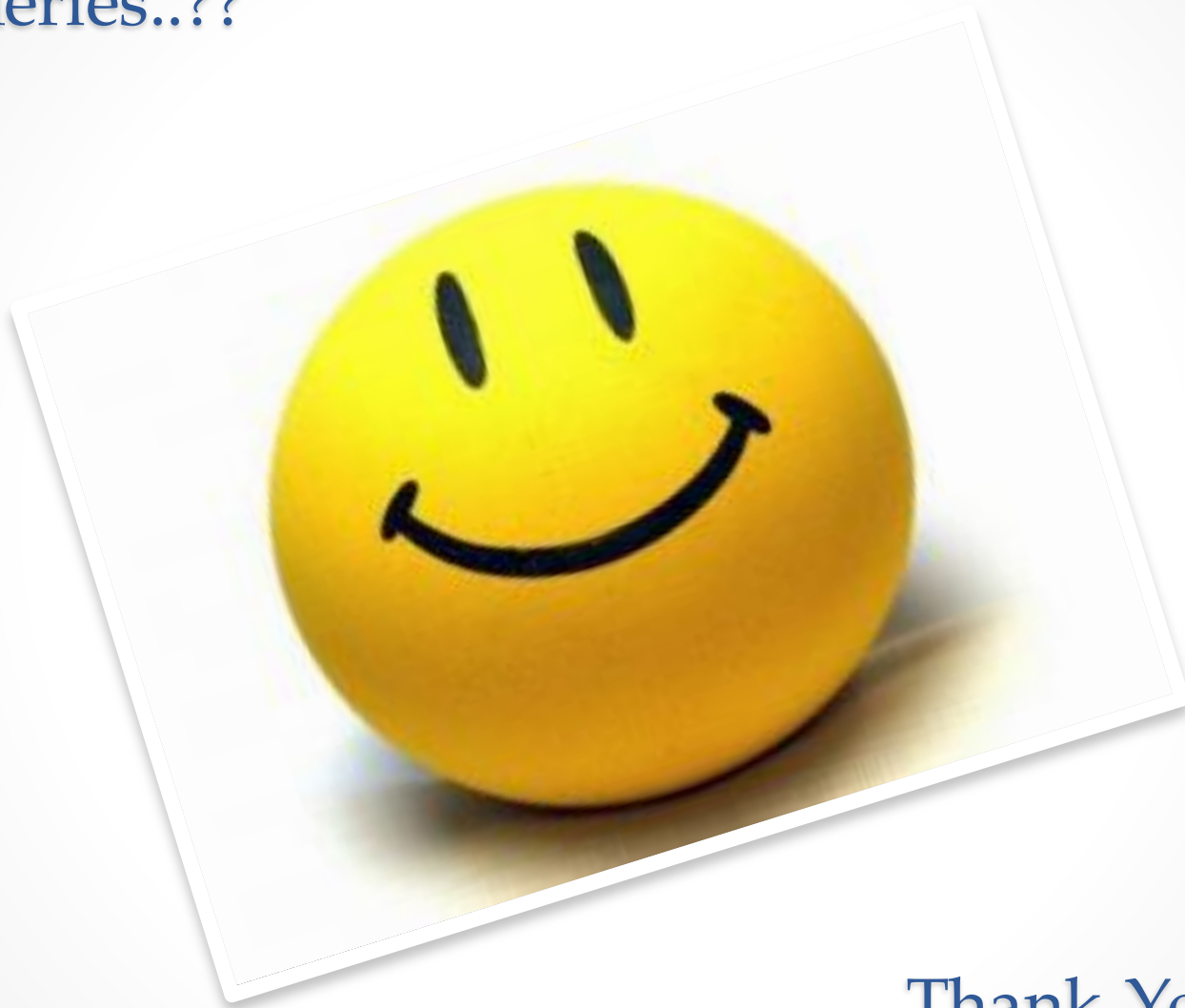

Thank You..😊