

Water quality and fish health

EIFAC
TECHNICAL
PAPER

54

by

Zdenka Svobodova

Research Institute of Fish Culture and Hydrobiology
Vodnany, Czech Republic

Richard Lloyd

"Wild Oaks", Woodside Little Baddow,
Chelmsford Essex, United Kingdom

Jana Machova

Blanka Vykusova

Research Institute of Fish Culture and Hydrobiology
Vodnany, Czech Republic

Food
And
Agriculture
Organization
of
the
United
Nations



ROME, 1993

The designations employed and the presentation of material in this publication do not imply the expression of any opinion whatsoever on the part of the Food and Agriculture Organization of the United Nations concerning the legal status of any country, territory, city or area or of its authorities, or concerning the delimitation of its frontiers or boundaries.

M-45
ISBN 92-5-103437-0

All rights reserved. No part of this publication may be reproduced, stored in a retrieval system, or transmitted in any form or by any means, electronic, mechanical, photocopying or otherwise, without the prior permission of the copyright owner. Applications for such permission, with a statement of the purpose and extent of the reproduction, should be addressed to the Director, Publications Division, Food and Agriculture Organization of the United Nations, Viale delle Terme di Caracalla, 00100 Rome, Italy.

© FAO 1993

PREPARATION OF THIS DOCUMENT

This publication is the result of edited lectures presented at the FAO (GCP/INT/526/JPN) International Training Course on Freshwater Fish Diseases and Intoxications: Diagnosis, Prophylaxis and Therapy, held in Vodnany, Czechoslovakia, June 15 – July 3, 1992. It is intended to serve as a training tool for similar courses, but it can be used also in courses of a broader character, as well as by fisheries managers seeking general background information in this field.

Comments and suggestions for additions and modifications of the text may be addressed to the authors of this publication. Copies of this document can be obtained from The Secretary, EIFAC, FAO, Fisheries Department, 00100 Rome, Italy, or from FAO, Distribution and Sales, at the same address.

Svobodová, Z.; Lloyd, R.; Máchová, J.; Vykusová, B.
Water quality and fish health.
EIFAC Technical Paper. No. 54. Rome, FAO. 1993. 59 p.

ABSTRACT

This publication is in a nature of a textbook. After the introduction on the natural and man-made inputs causing elevated levels of chemicals and organic matter in water, the text reviews the general responses of fish to such situations. A major chapter looks into the causes and effects of pollution on fish: harmful variations in natural water quality characteristics and chemicals in water as a result of man's activities. This is followed by a discussion on diagnosis of causes of fish poisoning, with a detailed checklist as an example of the information necessary to document a local investigation into the cause of abrupt changes in the behaviour or of mortality of fish. The chapter on the control of water quality includes general principles for preventing fish poisoning, evaluation of chemicals, preparations and effluents, persistence of substances in aquatic environment, and legislation. The final chapter briefly discusses pollution in relation to viral, bacterial and fungal diseases, and fish parasites.

Distribution:

FAO Fisheries Department
FAO Regional Fisheries Officers
Directors of Fisheries
EIFAC Mailing List
Authors

TABLE OF CONTENTS

	<u>PAGE</u>
1. Introduction	1
2. A brief review of adaptive mechanisms in fish	3
2.1 Respiration	3
2.2 Osmoregulation	5
2.3 Toxic substances in the water	6
2.4 Conclusions	7
3. Causes and effects of pollution on fish	7
3.1 Harmful variations in natural water quality characteristics	7
3.1.1 Water temperature	7
3.1.2 Water pH	8
3.1.3 Dissolved oxygen	9
3.1.4 Supersaturation with dissolved gas	11
3.1.5 Ammonia	11
3.1.5.1 Factors associated with ammonia toxicity	11
3.1.5.2 A field study of toxic gill necrosis in carp, and preventative measures	15
3.1.6 Nitrites and nitrates	16
3.1.7 Hydrogen sulphide (H ₂ S)	19
3.1.8 Carbon dioxide	19
3.1.9 Summary	20
3.2 Chemicals in water as a result of man's activities	20
3.2.1 Chlorine	21
3.2.2 Cyanides	21
3.2.3 Divalent metals and their salts	22
3.2.3.1 Aluminium	23
3.2.3.2 Chromium	23
3.2.3.3 Iron	24
3.2.3.4 Nickel	24
3.2.3.5 Copper	24
3.2.3.6 Zinc	25
3.2.3.7 Arsenic	25
3.2.3.8 Cadmium	26
3.2.3.9 Mercury	26
3.2.3.10 Lead	27
3.2.4 Phenols	27
3.2.5 Polychlorinated biphenyls (PCBs)	28
3.2.6 Surfactants	29
3.2.7 Pesticides	30

3.2.7.1	Chlorohydrocarbon (i.e. organochlorine) pesticides	31
3.2.7.2	Organo-phosphorus pesticides	32
3.2.7.3	Carbamate and thiocarbamate pesticides	32
3.2.7.4	Pesticides based on carboxylic acid derivatives	32
3.2.7.5	Pesticides based on substituted urea	33
3.2.7.6	Diazine and triazine pesticides	33
3.2.7.7	Synthetic pyrethroid pesticides	33
3.2.7.8	Pesticides based on metal compounds	33
3.2.8	Oils and refined products	33
3.2.9	Dyes	35
3.2.10	Phytoplankton toxins	35
4.	Diagnosing the cause of fish poisoning	36
4.1	Examination <i>in situ</i>	36
4.2	Hydrochemical examination	38
4.2.1	Water samples	39
4.2.2	Sediment samples	41
4.3	Hydrobiological examination	41
4.3.1	Aquatic communities	41
4.3.2	Examination of periphyton	42
4.3.3	Biological assay for water toxicity testing	42
4.3.4	Examination of the fish	43
5.	Control of water quality	45
5.1	General principles for preventing fish poisoning	45
5.2	Evaluation of the chemicals, preparations and effluents	46
5.2.1	General principles	46
5.2.2	Acute toxicity tests	47
5.2.3	Chronic toxicity tests	49
5.2.4	Other toxicity tests	51
5.3	Persistence of substances in aquatic environment	51
5.4	Legislation	52
6.	Pollution and fish diseases	53
6.1	Viral diseases	54
6.2	Bacterial diseases	55
6.3	Fungal diseases	56
6.4	Fish parasites	56
6.5	Conclusion	57
	References	57
	Central and East European Literature	59

1. INTRODUCTION

The chemistry of natural surface waters is complex, and depends on the equilibrium reached with the normal physical, chemical and biological characteristics of the surrounding environment. Thus, there can never be a normal surface water quality; every natural water will have a different composition.

Even rainwater varies in composition in different localities and regions. The precipitated water droplets will absorb acidic ions, volatile chemicals and fine particulate matter of natural and anthropogenic origin. A substantial proportion of the nitrogen input to soils comes with the winter rainfall. Recent data have shown that the level of atrazine in rain can be as high as $1 \mu\text{g l}^{-1}$ in areas where there is widespread use of this herbicide.

Rain that falls on soil overlying granite rock will tend to remain acidic and the run-off will be a soft water, low in calcium and bicarbonate. Water draining from areas of peat bogs will also be acidic, and can be extremely so with sudden rainfall after a prolonged dry period. Water with a low pH (<5.0) will dissolve naturally occurring metals from the soils and rocks, especially aluminium and in some areas copper, zinc and lead. Soft waters may be clear, or brown with varying amounts of dissolved humic substances.

Water falling on soil overlying chalk and limestone will become alkaline with a hardness depending on the amount of dissolved calcium and bicarbonate that it contains.

To some extent the surface water quality will depend on the type of vegetation covering the watershed, since the products of plant decay (as with the peat bogs mentioned above) will find their way into the streams draining the area. Water draining from coniferous forests tends to be acidic.

These are examples of natural causes of differences in water quality. Some indication has already been given of the added impact that can be caused by man's activities. Metal mining, by increasing the surface area of exposed rock to rainfall, can cause elevated concentrations of metals in drainage water. Commercial forestry can cause an increase in suspended mineral solids in the water after areas have been cleared by cutting and logging. Intensive agriculture can contribute fertilizers and pesticides applied to arable crops, and strong organic liquids can be produced from silage manufacture and from the rearing of poultry and cattle. Weaker organic wastes, but in much greater volumes, can be discharged in the form of untreated or treated sewage.

These various man-made inputs are shown in Fig. 1. A broad distinction can be made between point-source inputs which originate from pipe-line discharges, and diffuse inputs which can occur over a wide area.

As well as these changes in water chemistry, the physical habitat of the watercourse can be altered by man's activities. Rivers can be canalized for transport and flood prevention; dams are constructed for water storage and power generation; diversions are made to accommodate other land usage projects. These changes can affect the flow and depth of the water. Also, changes in the drainage characteristics of the watershed can lead to a more rapid run-off, leading to a greater fluctuations in the river flow rates.

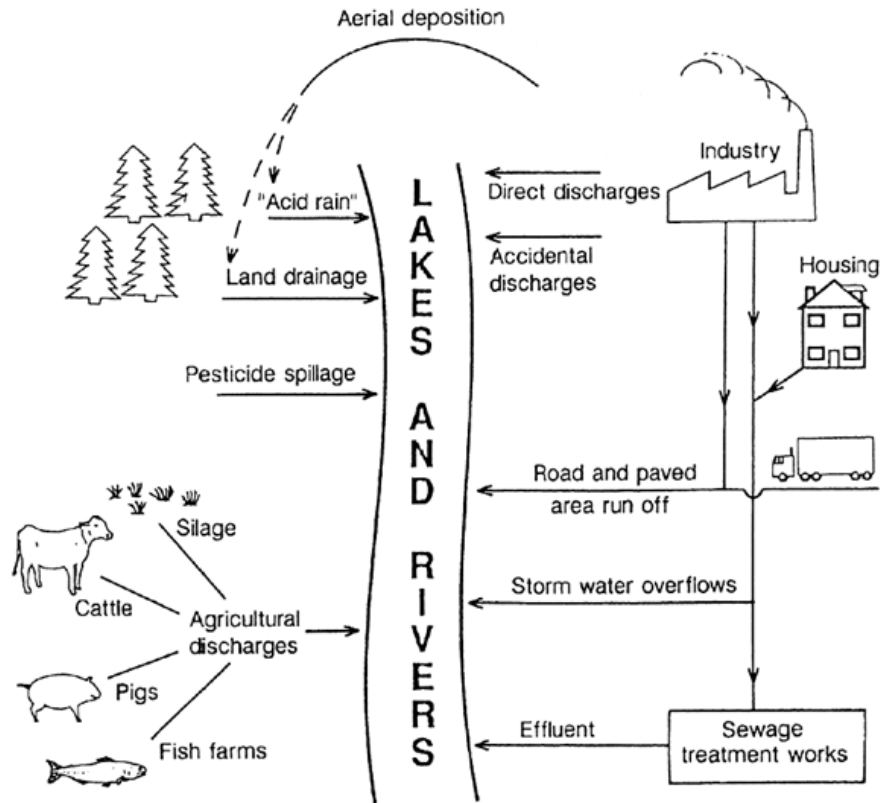

Fig. 1: Sources of man-made inputs into the aquatic environment (from Lloyd, 1992)

Mention should be made here of the diurnal and seasonal fluctuations of temperature. These are less susceptible to man's intervention, although changes in water depth and flow rates can affect the rates of diurnal warming and cooling. Obviously, heated discharges from power stations and industry can have a considerable effect on the aquatic biota.

Apart from affecting the suspended mineral solids content of the water, these physical changes *per se* have little effect on the chemical quality of the water. However, they can affect the natural biological community that can live in equilibrium with the particular chemical and physical characteristics of their environment, and changes in the composition of the aquatic biota can also affect the water quality.

The most obvious effects are those caused by increased plant growth. Clearly, rooted plants will provide shade and cover for a wide range of aquatic species. But all green plants, including algae, photosynthesize during their period of growth in the daylight hours, and respire at all times. During daylight, plants absorb carbon dioxide from the water and this is converted to carbohydrate; dissolved oxygen is produced and this is released into the water.

When plant growth is active, these photosynthetic processes are more pronounced than that of respiration, in which dissolved oxygen is absorbed and carbon dioxide is released. As a result, the pH of the water is raised during the day as the amount of carbonic acid is reduced; the dissolved oxygen concentrations are also raised during the day. At night, the level of carbon dioxide increases, leading to a lower pH, and the level of dissolved oxygen falls.

These fluctuations of dissolved gas concentrations are natural and normal, but they can be accentuated by, for example, an increase in the plant nutrients as a result of fertilizer run-off from arable land which can cause excessive weed growth. Also, the discharge of readily biodegradable organic wastes can increase the amplitude of the fluctuations.

Therefore, the quality of a surface water is never constant; it is constantly changing in response to daily, seasonal and climatic rhythms. Organisms, including fish, in a particular water-body can adapt to these natural fluctuations of water quality (including temperature) as they occur. The mechanisms involved in the adaptation of fish are outlined in the next Chapter.

2. A BRIEF REVIEW OF ADAPTIVE MECHANISMS IN FISH

2.1 Respiration

Fish obtain the oxygen that they require for their metabolic processes from the gas dissolved in water. The solubility of oxygen in water is low and depends on the temperature; at 5, 15 and 25°C the dissolved oxygen concentration is 12.8, 10.0 and 8.4 mg per litre respectively. These amounts are those for water in equilibrium with air, and are known as air saturation values. They will vary slightly with changes in barometric pressure. The saturation value for oxygen *per se* is about five times that for the air equilibrium value.

Because of this low concentration of dissolved oxygen in water, the fish has to have an extensive and efficient respiratory mechanism. This is shown diagrammatically in Fig. 2. Water flows through a sieve of parallel plates; each plate, or secondary lamellum, consists of a central sheet of pillar cells with concave sides that form blood spaces. These cells are covered by a thin epithelium. Oxygen diffuses from the water across the epithelial cells and the extensions of the pillar cells into the blood space.

To increase the efficiency further, the blood flows in the opposite direction to the water flow. This counter-current arrangement enables the almost fully utilized water of low oxygen content to come into close contact with (venous) blood with a low partial pressure of oxygen.

At the same time, carbon dioxide diffuses from the blood into the interlamellar space. Again, the counter current flows maximize the diffusion gradients, which may be enhanced still further by the presence of the enzyme carbonic anhydrase at the gill surface, which converts some of the gaseous CO₂ to carbonic acid.

When a fish is inactive, the respiratory apparatus is more than sufficient to supply the necessary amount of oxygen to the blood. Under such conditions, only a proportion of the secondary lamellae may be utilized for respiration, and the concentration of red blood cells may be reduced. The latter may assist the heart in that it will reduce the viscosity of the blood being pumped through the gill capillaries before then passing via the arteries to the capillaries of the various tissues.

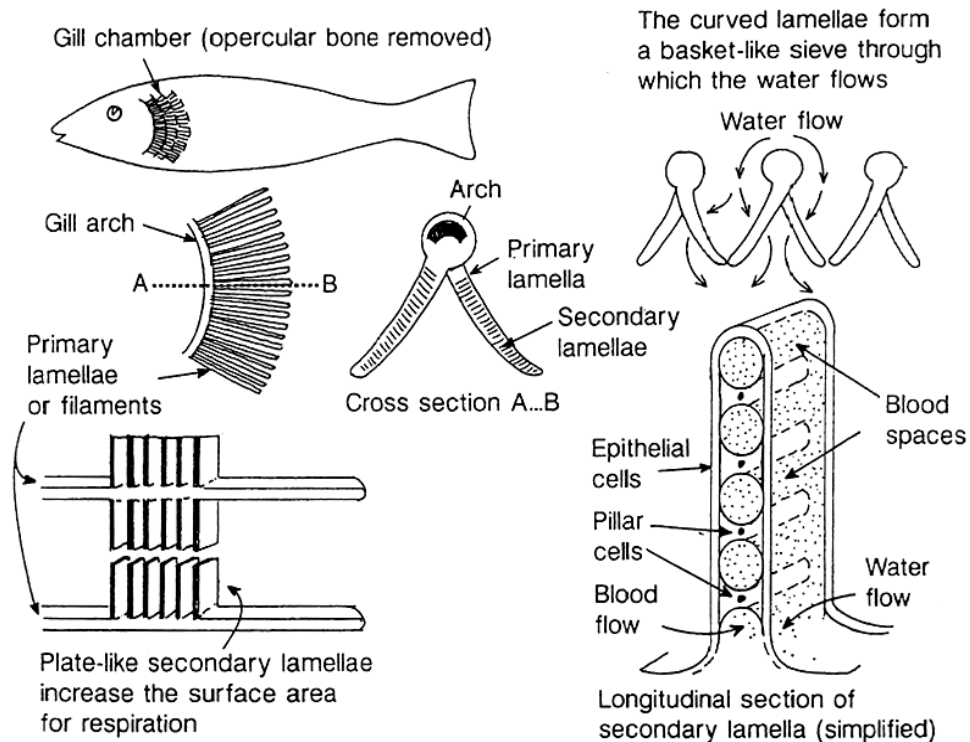

Fig. 2: Diagrammatic structure of fish gills (from Lloyd, 1992)

In response to a high energy demand, or a low concentration of dissolved oxygen in the water, the fish can respond in two ways: the blood flow can be increased by opening up further secondary lamellae to increase the effective respiratory area (it may be difficult to increase significantly the blood flow rate through the capillaries themselves), and the concentration of red blood corpuscles can be increased to raise the oxygen carrying capacity of the blood per unit volume. The latter can be achieved by reducing the blood plasma volume (e.g. by increasing the urine flow rate) in the short term, and by releasing extra blood corpuscles from the spleen in the longer term.

At the same time, the ventilation rate is increased to bring more water into contact with the gills within a unit time. There are, however, limits on the increased flow attainable; the space between the secondary lamellae is narrow (in trout it is about $20\mu\text{m}$) and water will tend to be forced past the tips of the primary lamellae when the respiratory water flow is high, thus by-passing the respiratory surfaces.

These reactions are quite adequate to compensate for the normal fluctuations of energy demands of the fish and of dissolved oxygen concentrations in the water. One of the consequences, however, of an increased ventilation rate is that there will be an increase in the amount of toxic substances in the water reaching the gill surface where they can be absorbed.

2.2 Osmoregulation

Because the osmotic pressure of the body fluids of fish is considerably higher than that of freshwater, there will be a continuous influx of water across the surface epithelium and a corresponding loss of ions into the water. These fluxes occur over the whole body surface, but particularly at the gills which are relatively unprotected in this respect. Elsewhere, fluxes can be relatively high in the fins, but the remainder of the body is protected by a tough epithelium (and usually scales), and a covering of mucus.

The influx of water is balanced by a copious discharge of urine, from which as much sodium and chloride as possible has been re-absorbed in the kidneys. These organs do not control the osmotic pressure of the internal fluids; such control is exerted by special cells in the gill epithelium, whereby sodium is taken up in exchange for hydrogen ions, and chloride in exchange for bicarbonate. The internal hydrogen and bicarbonate is derived from respiratory carbon dioxide in the blood. These processes are shown in Fig. 3.

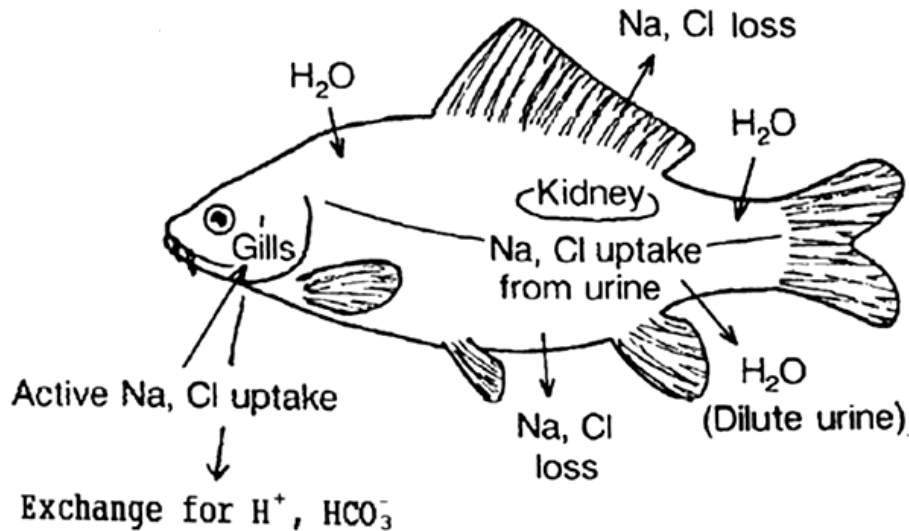

Fig. 3: The osmotic balance in fish (after Lloyd, 1992)

It is clear that damage to the integument, the fins, the ability to secrete mucus or its removal from the body surface, will lead to an osmotic imbalance. Similarly, damage to the gill epithelium will affect the ability of the fish to control their internal osmotic pressure.

2.3 Toxic substances in the water

It is not the purpose of this document to deal with this aspect of adaptation in any depth. The following brief summary describes the salient features.

Fish have become genetically adapted to live in such diverse environments as cold, soft, arctic waters to warm muddy rivers in the tropics. Transfer of fish between these environments is not possible. In the same way, there is a limited potential for genetic adaptation to extreme conditions within a particular environment; for example, to extreme acidity in waters affected by acid rain, or to elevated levels of zinc in waters affected by historic mining activities.

In general, however, most of the adaptations that do occur are due to the limited ability of individual fish to detoxify the harmful chemicals entering the body, e.g. by enhancing the biochemical processes involved. For example, high levels of ammonia in the water are toxic to fish; however, the end-product of protein catabolism in fish is ammonia which is excreted by the gills. A limited adaptation to ammonia can be obtained by enhancing the excretory mechanism.

Similarly, elevated levels of zinc and copper in the water can be harmful, although at lower levels they are essential elements for fish. The internal concentrations of these metals are maintained by translocating them as complexes with metallothioneins (proteins) and perhaps by depositing surplus metals in the form of inert

granules. These mechanisms can be enhanced to a certain extent to cope with limited increased metal levels in the surrounding water.

Many organic compounds can be metabolized and detoxified in the liver; residues can be excreted in the urine or via the bile through the gut. Again, there is a limited capacity for these mechanisms to become enhanced to cope with increased uptake of potentially harmful chemicals from the water. The existence of such mechanism can be demonstrated by placing fish which have been exposed to sub-lethal concentrations of a toxicant into higher concentrations and comparing their survival times with those not previously exposed. In general, it is unusual to find that fish can achieve more than a four-fold increase in resistance to a toxic substance.

2.4 Conclusions

It is very important to bear these adaptive potentials in mind when considering the effects of pollution on fish. In particular, the rate of change in the water quality may be important in determining whether the change is harmful; it may take some time for the adaption to be completed. This will be considered later in the context of temperature variations.

It is also important to remember that the natural environment is rarely stable and that fish have to constantly adapt to the changes. If these changes are made within the natural limits and rates, then the fish are not placed under stress. It is only when these limits and rates are exceeded, or the normal physiological functions and controls become damaged, that stress occurs. Such damage, especially to the integument, can lead to an increased susceptibility to disease.

3. CAUSES AND EFFECTS OF POLLUTION ON FISH

In the previous chapters, the sources of pollution, the general responses of fish to natural and man-made changes in the aquatic environment, and to some extent their interactions, were considered in outline. This chapter, much of it based on Alabaster and Lloyd (1980), considers the important factors involved on an individual basis and in greater detail.

3.1 Harmful variations in natural water quality characteristics

The following physico-chemical changes in the aquatic environment are those most frequently recorded as the primary causes of harm to fish in fish culture installations.

3.1.1 Water temperature

Fish are poikilothermic animals, that is, their body temperature is the same as, or 0.5 to 1°C above or below, the temperature of the water in which they live. The metabolic rate of fish is closely correlated to the water temperature: the higher the water temperature (i.e. the closer to the optimum values within the normal range), the greater the metabolism. This generalisation applies particularly to warm-water fish. Cold-water fish, e.g. salmonids, whitefish, or burbot, have a different type of metabolism: their metabolic rate can continue at comparatively low temperatures, whereas at high water temperatures, usually above 20°C, they become less active and consume less food. Water temperature also has a great influence on the initiation and course of a number of fish diseases. The immune system of the majority of fish species has an optimum performance at water temperatures of about 15°C.

In their natural environment, fish can easily tolerate the seasonal changes in temperature, e.g. a decrease to 0°C in winter and increase to 20–30°C (depending on

species) in summer under Central European conditions. However, these changes should not be abrupt; temperature shock occurs if the fish are put into a new environment where the temperature is 12°C colder or warmer (8°C in the case of salmonids) than the original water. Under these conditions fish may die, showing symptoms of paralysis of the respiratory and cardiac muscles. With young fry, problems may arise even where the difference in temperature is as low as 1.5–3°C. If fish are fed and then abruptly transferred to water colder by 8°C or more, their digestive processes will slow down or stop. The food will remain undigested or half-digested in the digestive tract and the gases produced can cause the fish to become bloated, lose balance, and finally die. If carp are given a high-nitrogen feed (e.g. natural food or high-protein pellets), abrupt transfer to much colder water will considerably increase the level of ammonia nitrogen in the blood serum because the decrease in metabolic rate reduces the diffusion of ammonia from the gills. This can lead to ammonia autointoxication and death.

Considerable progress has been made recently in warm water fish culture. Techniques for water temperature control enables optimal condition to be maintained, so that the fish can fully utilize their growth potential to achieve maximum weight gains.

3.1.2 Water pH

The optimal pH range for fish is from 6.5 to 8.5. Alkaline pH values above 9.2 and acidity below 4.8 can damage and kill salmonids (e.g. brown and rainbow trout); and pH values above 10.8 and below 5.0 may be rapidly fatal to cyprinids (especially carp and tench). Thus salmonids, in comparison with cyprinids, are more vulnerable to high pH and more resistant to low pH. The American char is especially resistant to acid waters and can tolerate pH levels as low as 4.5–5.0.

Low water pH most frequently occurs during the spring, especially when acidified snow melts, and in water draining peat bogs. High alkaline pH can occur in eutrophic reservoirs (ponds) where the green plants (the blue-green algae, green algae and higher aquatic plants) take up considerable amounts of CO₂ during the day for intensive photosynthetic activity. This affects the buffering capacity of the water and the pH can rise to 9.0–10.0 or even higher if bicarbonate is adsorbed from waters of medium alkalinity. Water pH can also be changed when mineral acids and hydroxides, or other acidic or alkaline substances, are discharged or leach into water courses, ponds or lakes.

As a defence against the effect of a low or high water pH, fish can produce an increased amount of mucus on the skin and on the inner side of the gill covers. Extremely high or low pH values cause damage to fish tissues, especially the gills, and haemorrhages may occur in the gills and on the lower part of the body. Excess amounts of mucus, often containing blood, can be seen in post mortem examination of the skin and gills. The mucus is dull-coloured and watery.

Water pH also has a significant influence on the toxic action of a number of other substances (e.g. ammonia, hydrogen sulphide, cyanides, and heavy metals) on fish.

3.1.3 Dissolved oxygen

Oxygen diffuses into the water from the air especially where the surface is turbulent and also from the photosynthesis of aquatic plants. On the other hand, oxygen is removed by the aerobic degradation of organic substances by bacteria and by the respiration of all the organisms present in the water, as mentioned earlier. The concentration of oxygen dissolved in water can be expressed as mg per litre or as percentage of air saturation value. Water temperature, atmospheric pressure and

contents of salts dissolved in water have to be taken into account when the values in mg per litre are converted to % saturation or vice versa.

Different fish species have different requirements for the concentration of oxygen dissolved in water. Salmonids have the more demanding requirements for oxygen in the water; their optimum concentration is 8–10 mg per litre, and if the level declines below 3 mg per litre they begin to show signs of suffocation. Cyprinids are less demanding; they can thrive in water containing 6–8 mg per litre and show signs of suffocation only, when the oxygen concentration falls to 1.5–2.0 mg per litre.

The oxygen requirements of fish also depend on a number of other factors, including the temperature, pH, and CO₂ level of the water, and the metabolic rate of the fish. The major criteria for the oxygen requirement of fish include temperature, and the average individual weight and the total weight of fish per unit volume of water. Oxygen requirements increase at a higher temperature (e.g. an increase in water temperature from 10 to 20°C at least doubles the oxygen demand); a higher total weight of fish per unit volume of water can lead to increased activity and thus increased respiration as a result of overcrowding.

Oxygen requirements per unit weight of fish significantly decline with increasing individual weight. In carp this reduction may be expressed by the following ratios: yearling = 1, two-year-old carp = 0.5–0.7, marketable carp = 0.3–0.4. Significant differences in oxygen demand are also found for different species. Using a coefficient of 1 to express the oxygen requirement of common carp, the comparative values for some other species are as follows: trout 2.83, peled 2.20, pike perch 1.76, roach 1.51, sturgeon 1.50, perch 1.46, bream 1.41, pike 1.10, eel 0.83, and tench 0.83.

As stated earlier, the factor most frequently responsible for a significant reduction in the oxygen concentration of the water (oxygen deficiency¹) is pollution by biodegradable organic substances (including waste waters from agriculture, the food industry, and public sewage). These substances are decomposed by bacteria which use oxygen from the water for this process. A few chemicals may be oxidized in the absence of bacteria. The concentration of organic substances in water in terms of their capacity for taking oxygen from the water can be measured by means of the chemical oxygen demand (COD, which represents a theoretical maximum) and the biochemical oxygen demand within five days (BOD₅, which represents the potential for bacterial degradation). The upper limit of COD, as determined by the Kubela method, for the optimal range for cyprinids in pond or river waters, is 20–30 mg O₂ per litre and the corresponding BOD₅ limit for cyprinids is 8–15 mg O₂ per litre, depending on the intensity of the culture and the rates of reaeration. For salmonids the corresponding levels are up to 10 mg O₂ per litre for COD and up to 5 mg O₂ per litre for BOD.

In winter, fish are commonly killed by suffocation in polluted storage ponds and in summer this often happens in polluted water courses with high temperatures and low flow rates. In severely eutrophicated ponds, oxygen deficiency often occurs during the summer early in morning as a result of the night time oxygen consumption by bacteria for the decomposition of organic substances and the respiration of aquatic plants. In heavily fertilized ponds (e.g. those used for the treatment of sewage) with a constant inflow of degradable organic substances, oxygen deficiency can also be caused by an excessive development of zooplankton; the zooplankton itself requires oxygen for respiration and, in addition, its feeding pressure reduces the phytoplankton population which produces oxygen during the day.

Even in ponds where the oxygen levels have been satisfactory during the summer, when plant growth was vigorous, severe oxygen deficiencies can occur in the autumn when the plants begin to die and decompose. This deficiency can be more pronounced if the sky is heavily overcast during the day, so that the limited oxygen production by photosynthesis is further reduced. In these cases, the maximum oxygen deficiency occurs just before daybreak.

In summary, the oxygen levels in water depend on the balance between the inputs from the air and plants, and the consumption by all forms of life. Inputs from the air depend on the turbulence of the air-water interface, and the oxygen deficiency of the water. Inputs from plants depend on photosynthetic activity which increases with temperature and sunlight; excess oxygen can be lost to the atmosphere. Oxygen consumption depends on the respiration of aquatic organisms, including plants, and the aerobic decomposition of organic material by bacteria; these rates also increase with temperature.

This balance needs to be clearly understood; a satisfactory oxygen level recorded during the day is no guarantee that the levels will be maintained during the night. Moderate levels recorded in calm eutrophic waters on a warm, sunny afternoon will almost always indicate that severe oxygen deficiencies will occur during the night. Also, lower than expected daytime pH values due to high levels of CO₂ may indicate high levels of bacterial respiration which could lead to low night-time oxygen levels.

Oxygen deficiency causes asphyxiation and fish will die, depending on the oxygen requirements of the species and to a lesser extent on their rate of adaptation. Fish exposed to oxygen deficient water do not take food, collect near the water surface, gasp for air (cyprinids), gather at the inflow to ponds where the oxygen levels are higher, become torpid, fail to react to irritation, lose their ability to escape capture and ultimately die. The major pathologico-anatomic changes include a very pale skin colour, congestion of the cyanotic blood in the gills, adherence of the gill lamellae, and small haemorrhages in the front of the ocular cavity and in the skin of the gill covers. In the majority of predatory fishes the mouth gapes spasmodically and the operculum over the gills remains loosely open.

Remedial action is to either reduce the input of degradable material, or to aerate the water. The latter is usually the best option; aeration can be with air or oxygen pumps, or by spraying the water into the air in the form of a fountain, or by increasing the input of aerated water. It must be remembered that these remedial actions are most important at night when the oxygen deficiency is likely to be at its greatest.

Damage caused to fish by too much oxygen dissolved in water is seldom encountered. However, it may happen, for example, when fish are transported in polythene bags with an oxygen-filled air space. The critical oxygen level of water is 250 to 300% of the air saturation value; fish may be injured at higher values. The gills of such affected fish have a conspicuous light red colour and the ends of the gill lamellae fray. When such fish are used for stocking waters they may suffer from secondary fungus infections and some of them may die. It is possible that fish adapted to such high oxygen levels need to be progressively acclimatized to more normal concentrations. The condition described here should not be confused with the supersaturation of water with dissolved gas, which can cause gas bubble disease.

¹ Oxygen deficiency is the appropriate saturation value minus the actual value in the water.

3.1.4 Supersaturation with dissolved gas

Supersaturation with dissolved gas occurs when the pressure of the dissolved gas exceeds the atmospheric pressure. It occurs when water is equilibrated with air under pressure, e.g. at the bottom of a lake or reservoir, in ground water, or if air is drawn into a centrifugal water pump. It can also occur if cold air-equilibrated water is warmed up without re-equilibration to the higher temperature. A bottle containing such water will show either minute bubbles forming as a cloudy suspension which will clear from the bottom upwards, or larger bubbles forming on the glass wall. This is analogous to that seen in an opened bottle of carbonated drinking water.

If fish are exposed (at a lower atmospheric pressure) to such water, their blood equilibrates with the excess pressure in the water. Bubbles form in the blood and these can block the capillaries; in sub-acute cases the dorsal and caudal fin can be affected, and bubbles may be visible between the fin rays. The epidermal tissue distal to the occlusions then becomes necrotic and cases are known where the dorsal fins of trout have become completely eroded. In severe cases, death occurs rapidly as a result of blockage of the major arteries, and large bubbles are clearly seen between the rays of all the fins. A similar effect of gas bubbles forming in the blood can be experienced by deep-sea divers when they return to the surface.

The remedy is either to remove the fish to normally equilibrated water or to provide vigorous aeration to strip out the excess gas.

3.1.5 Ammonia

3.1.5.1 Factors associated with ammonia toxicity

Ammonia pollution of water courses, ponds and lakes may be of organic origin (domestic sewage, agricultural wastes, or the reduction of nitrates and nitrites by bacteria in anoxic waters) or of inorganic origin (industrial effluents from gas works, coking plants and power generator stations). In water or in biological fluids, ammonia is present in a molecular (nondissociated) form (NH_3) and in the form of ammonia ion (dissociated) (NH_4^+). The ratio between these two forms depends on the pH and temperature of the water (Table 1). The cell walls of organisms are comparatively impermeable to the ammonia ion (NH_4^+), but molecular ammonia (NH_3) can readily diffuse across the tissue barriers where a concentration gradient exists, and is therefore the potentially toxic form to fish. Also, under normal conditions there is an acid-base balance at the water-tissue interface. If this balance is altered, the side on which the pH is lower will attract additional molecular ammonia. This explains how molecular ammonia passes from water through the epithelium of the gills to the blood and also how it passes from the blood to the tissues. Ammonia has a particular toxic effect on the brain; this is why nervous symptoms are so pronounced in cases of ammonia toxicity to fish.

Water quality monitoring of water courses, lakes and fish culture facilities includes the measurement of total ammonia concentrations. To assess the potential toxicity of these concentrations it is important to know the amount of nondissociated ammonia (NH_3) present. This is calculated from the measured values for total ammonia ($\text{NH}_4^+ + \text{NH}_3$), temperature (T, °C) and water pH, using the formula:

$$\text{NH}_3 = \frac{\text{NH}_4^+ + \text{NH}_3}{10^{(10.07 - 0.33T - \text{pH})} + 1}$$

Alternatively, the values can be interpolated from Table 1 compiled from calculations on the basis of this formula.

Table 1: The NH₃ content (as % of total ammonia) of water at different pH values and temperature

pH	T °C					
	0	5	10	15	20	25
7.0	0.082	0.12	0.175	0.26	0.37	0.55
7.2	0.13	0.19	0.28	0.41	0.59	0.86
7.4	0.21	0.30	0.44	0.64	0.94	1.36
7.6	0.33	0.48	0.69	1.01	1.47	2.14
7.8	0.52	0.75	1.09	1.60	2.32	3.35
8.0	0.82	1.19	1.73	2.51	3.62	5.21
8.2	1.29	1.87	2.71	3.91	5.62	8.01
8.4	2.02	2.93	4.23	6.06	8.63	12.13
8.6	3.17	4.57	6.54	9.28	13.02	17.95
8.8	4.93	7.05	9.98	13.95	19.17	25.75
9.0	7.60	10.73	14.95	20.45	27.32	35.46
9.2	11.53	16.00	21.79	28.95	37.33	46.55
9.4	17.12	23.19	30.36	39.23	48.56	57.99
9.6	24.66	32.37	41.17	50.58	59.94	68.63
9.8	34.16	43.14	52.59	61.86	70.34	77.62
10.0	45.12	54.59	63.74	71.99	78.98	84.60
10.2	56.58	65.58	73.59	80.29	85.63	89.70
10.4	67.38	75.12	81.54	86.59	90.42	93.24
11.0	89.16	92.32	94.62	96.26	97.41	98.21

Besides water temperature and pH, other factors that influence ammonia toxicity include the concentration of dissolved oxygen in water; the lower the oxygen concentration in water, the greater the toxicity of ammonia (Fig. 4).

To a lesser extent, the toxicity of ammonia is affected by the amount of free CO₂ in the water. This is because the diffusion of respiratory CO₂ at the gill surface reduces the pH of the water, thus reducing the proportion of nondissociated ammonia there. The extent of the reduction in pH depends on the amount of CO₂ already present in the water.

In general, Table 1 shows that the toxicity of ammonia will be much greater in warm alkaline waters than in cold acid waters.

Non-dissociated ammonia is highly toxic to fish. The LC₅₀ values, determined in acute toxicity tests, are in the range of 1.0 to 1.5 mg NH₃ per litre for cyprinid fish and 0.5 to 0.8 mg NH₃ per litre for salmonids. The maximum admissible ammonia (NH₃) concentration is 0.05 mg per litre for cyprinids and 0.0125 mg per litre for salmonids.

It should be emphasized here that these standards apply to ammonia as a toxic substance. Other standards for total ammonia are applied to control eutrophication of waters and prevent excessive algal and plant growth that can cause physical problems and affect the oxygen balance.

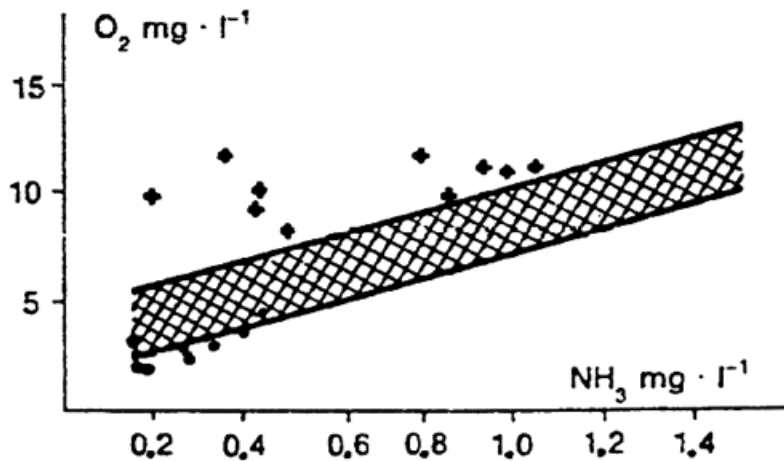

Fig. 4: With low levels of oxygen in the water, lower concentrations non-dissociated ammonia can kill fish:

- fatal cases;
 - + waters where no cases of injury to fish occurred in March to April;
- hatched area = lethal boundary of non-dissociated ammonia
(Vámos and Szöllözy, 1974)

The first signs of ammonia toxicity include a slight restlessness, and increased respiration; the fish congregate close to the water surface. In later stages, cyprinids gasp for air, their restlessness increases with rapid movements and respiration becomes irregular; then follows a stage of intense activity. Finally, the fish react violently to outside stimuli; they lose their balance, leap out of the water, and their muscles twitch in spasms. Affected fish lie on their side and spasmodically open wide their mouths and gill opercula. Then follows a short period of apparent recovery. The fish return to normal swimming and appear slightly restless. This stage is then replaced by another period of high activity; the body surface becomes pale and the fish die.

The skin of ammonia poisoned fish is light in colour, and covered with a thick or excessive layer of mucus. In some cases small haemorrhages occur, mainly at the base of the pectoral fins and in the anterior part of the ocular cavity. The gills are heavily congested and contain a considerable amount of mucus; fish exposed to high ammonia concentrations may have slight to severe bleeding of the gills. Intense mucus production can be observed on the inner side of the gill opercula, mainly at the posterior end. The organs inside the body cavity are congested and parenchymatous, and show dystrophic changes.

In recent years, considerable losses among farmed carp have been caused by the so-called toxic necrosis of the gills. The factors responsible for the occurrence of this disease include ammonia poisoning in which the ammonia level in the blood is considerably increased. As stated earlier, ammonia is the final product of nitrogen metabolism in carp (as it is in other species) and most of it is excreted via the gills into the water. If the diffusion rate is reduced for some reason or another (high water pH, oxygen deficit, damaged gills etc.), the ammonia level in the blood will steadily rise, causing a condition known as autointoxication, which may lead to toxic gill necrosis in carp.

A very interesting case of autointoxication among carp yearlings (C₁) where extremely high ammonia N levels were found in the blood serum occurred after their

transfer from a pond to well water in large aquarium tanks. Some of the fish caught and transferred during the morning exhibited typical symptoms of ammonia poisoning the following morning. These symptoms included considerable restlessness, increased respiration, leaping out of the water, uncoordinated activity, and tonic-clonic spasms of the muscles. The skin of the affected fish was light in colour; the gills were heavily congested, dark red and showed oedematous swellings (particularly severe on the edges of the gill filaments). It is known that ammonia toxicity is accompanied by an increase in the permeability of the fish epithelium to water, as measured by an increase in the flow of urine. If the kidneys cannot cope with the increased water influx, oedema is likely to occur. An increased water influx may also occur if the skin or the mucus coating of the fish is damaged by handling and during transport. The histopathological changes in the gills corresponded with what had been described for toxic necrosis of carp gills. The digestive tract of those fish with severe poisoning symptoms was filled with undigested food. On the other hand, fish that had cleared their gut (faeces found on the bottom of the tank, the gut almost empty), were free from symptoms of toxic damage. The average blood serum level of ammonia N in the fish with symptoms of poisoning was 3054 (2400–3600) μg per 100 ml of serum, whereas in the fish free of such symptoms the ammonia level was 825 (750–900) μg per 100 ml of serum. In the affected fish the auto-intoxication, associated with the considerable increase in the blood serum ammonia N level, was probably due to the persistence and absorption of the gut contents (natural food and high-protein feed pellets) of the carp exposed to environmental stress (confinement and reduced oxygen level during transport, and water temperature reduced by about 5°C).

On the basis of this case of ammonia poisoning of carp, some other unexplained incidents of rapid death among fish may be ascribed to a similar cause. Such events may occur mainly in carp farms where there is an intensive feeding with a high-nitrogen diet, if the fish are also exposed to other stresses caused by e.g. an abrupt oxygen deficit, or sudden changes in water temperature.

3.1.5.2 A field study of toxic gill necrosis in carp, and preventative measures

Toxic gill necrosis was diagnosed in fish from the Dřemlín pond on May 2, 1984; about 50% of two- and three-year-old carp died (Svobodová et al., 1987, Fig. 5). The clinical signs of toxic gill necrosis in carp included the congregation of the fish in the deeper and shaded part of the pond and subsequently, in the advanced stage of disease the body surface darkened and there was a reduced or total absence of the escape response. Respiration was laboured and the fish did not feed.

Pronounced hyperaemia, oedematous swelling and increased accumulation of mucus in the gills are typical features of the patho-anatomic picture. These are followed by a gill necrosis and separation of the epithelium from the gill lamellae. The pillar cells of the gill lamellae are completely exposed over the whole lamellar surface. In the later stages of the disease, necrotic gill lamellae become detached and the margins of the gills are distorted. Histological and pathological examination reveals venostasis, swelling, vacuolization and separation of the respiratory epithelial cells from basal membrane in the gills. Associated with these effects is an increase in the activity of chloride cells in the lamellar epithelium. Dystrophic and necrobiotic cells from the respiratory epithelium (including chloride cells) create a compact mass of debris in the interlamellar space of gills. Extensive effects are characterized by a total lysis and necrotic changes in the cell nucleus. A significant increase in the ammonia level of blood serum in fish is a specific feature of these effects. The normal physiological level of ammonia in the blood serum of carp ranges from 350 to 800 μg N in 100 ml. The

ammonia level in the blood serum of carp with toxic gill necrosis fluctuates between 2000 and 4800 $\mu\text{g N}$ per 100 ml, while 1000 to 2500 $\mu\text{g N}$ in 100 ml serum are found in the early stages of toxic necrosis. In other gill diseases that cause necrosis, the following levels of ammonia in blood serum have been found (as N per 100 ml): bacterial diseases 420–900 μg , dactylogyrosis 500–730 μg , branchiomycosis 450–700 μg , and sphaerosporosis 450–960 μg .

The diagnosis of toxic necrosis is based on a detailed examination of fish. The main specific effect in carp is the elevated ammonia level in the blood serum. However, because such toxic gill necrosis can be caused by other unfavourable conditions in the pond environment (Fig. 5), a detailed hydrochemical and hydrobiological analysis of pond water is necessary to provide a definitive diagnosis.

Preventive measures to control frequent outbreaks of gill necrosis in carp in highly eutrophic ponds are centred on optimizing of the hydrobiological and hydrochemical conditions and ensuring the healthy state of fish stock (e.g. by a proper control of the feeding of fish). Stocking the ponds with fish at the correct time in the spring, and preventing or oxygen deficiency, are among the most important preventive measures.

In this context a simple biological test has been developed to determine the optimum timing for the spring stocking of two-year-old carp into ponds with a history of toxic gill necrosis. This test is based on the ability of carp to eliminate ammonia (under the existing physical and chemical conditions of the pond water) given as an oral dose of 350 mg. 100 ml^{-1} in starch gel. If the ammonia level in the blood serum decreases to the original value within 6 hours of the dose being given, the fish can be stocked in pond. On the other hand, if the ammonia level in the blood serum remains at a threefold higher level than the original value, the stocking of fish must be postponed until the physical and chemical conditions of pond water allow the fish to eliminate the toxic ammonia.

Application of the pesticide Soldep at a rate 200 ml ha^{-1} (depth of pond 1 m on average) can ensure the survival of the fish stock when an overproduction of zooplankton, followed by an oxygen deficiency, is expected. Soldep is effective in controlling the daphnid zooplankton and should be applied when there is still a reasonable phytoplankton community in the pond. Both during and after the Soldep application to the pond, standardized safety regulations must be followed (Svobodová and Faina, 1984).

3.1.6 Nitrites and nitrates

Nitrites as a rule are found together with nitrates and ammonia nitrogen in surface waters but their concentrations are usually low because of their instability. They are readily oxidized to nitrate or reduced to ammonia, both chemically and biochemically by bacteria. Nitrates are the final product of the aerobic decomposition of organic nitrogen compounds. They are present in low concentrations in all surface waters. There is almost no nitrate retention in soil, so it is readily leached to watercourses, ponds and lakes. The main sources of nitrate pollution of surface waters is the use of nitrogenous fertilizers and manures on arable land leading to diffuse inputs, and the discharge of sewage effluents from treatment works.

Nitrite can be associated with ammonia concentrations in the water. In normal aerobic conditions, ammonia is oxidized to nitrite and then to nitrate by two separate bacterial actions. If the second stage of oxidation is inhibited by bactericidal chemicals in the water, nitrite concentrations will increase. This may be important in small ponds or

aquaria where water is recirculated through a purification filter; the ammonia-oxidizing bacteria need to become established for the filter to function, and they may be affected by the use of antibiotics to control fish diseases.

The toxic action of nitrite on fish is incompletely known; it depends on a number of internal and external factors (such as fish species and age, and general water quality). The importance and role of these factors have been frequently studied and reviewed. Different authors often come to contradictory conclusions, and usually fail to offer a definitive explanation of either the mechanism of nitrite toxic action on fish or the modifying effects of different environmental factors.

It is now clear that nitrite ions are taken up into the fish by the chloride cells of the gills. In the blood, nitrites become bound to haemoglobin, giving rise to methaemoglobin: this then reduces the oxygen transporting capacity of the blood. The increase in the amount of methaemoglobin can be seen as a brown colour of the blood and gills. If the amount of methaemoglobin in the blood does not exceed 50% of the total haemoglobin, the fish usually survive. If the fish have more methaemoglobin in their blood (70–80%) they become torpid, and with a further increase in the methaemoglobin level they lose their orientation and are unable to react to stimuli. Nevertheless, the fish may still be able to survive because the erythrocytes in their blood contain the enzyme reductase which can convert methaemoglobin to haemoglobin. This process can return the haemoglobin to its normal level within 24–48 hours, if the fish are put into nitrite-free water.

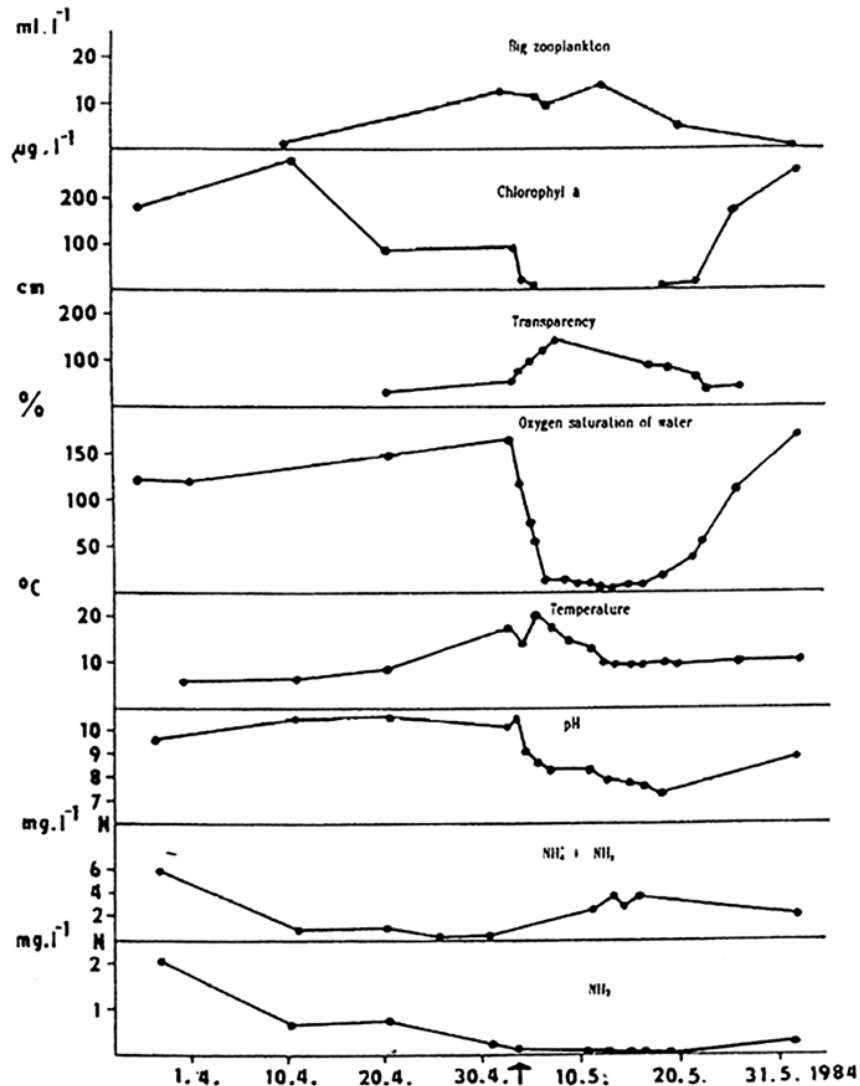

Fig. 5: Hydrobiological and hydrochemical conditions in the Dremliny Pond before and during the course of toxic gill necrosis in carp. Toxic necrosis was diagnosed on 2 May 1984.

Several authors have shown that nitrite toxicity to fish can be affected by certain water quality characteristics (e.g. Lewis and Morris, 1986). In this investigation, the 96h LC50 for rainbow trout ranged from 0.24 to 12.20 mg per litre, depending on the chloride content of the dilution water (in this case the chloride content ranged from 0.35 to 40.9 mg per litre). The effect of chloride on nitrite toxicity is so marked that the results of tests made without recording the chloride concentrations in the water cannot be compared with those of other tests.

It is now known that the chloride cells in the fish gills cannot distinguish between nitrite and chloride ions; both are transported across the gill epithelium. The rate of nitrite uptake depends therefore on the nitrite-chloride ratio in the water.

Nitrite toxicity can be also influenced by bicarbonate, potassium, sodium, calcium and other ions, but their effect is not so great as that of chloride. Among these, potassium is the more significant, and that of sodium and calcium is less. These

monovalent ions are also involved in the ionic fluxes across the gill epithelium and so directly or indirectly influence the uptake of nitrite. The pH value has also been considered as important for nitrite toxicity; pH and temperature control dissociation between NO_2^- and nondissociated HNO_2 and it was believed that the uptake of nitrites into fish blood plasma depended on the diffusion of nondissociated HNO_2 across the gill epithelium. However, the results of later experiments refuted these theories and showed that within the acidity-alkalinity range encountered in natural waters the pH is of little importance in nitrite toxicity.

Another factor that influences nitrite toxicity is the dissolved oxygen concentration and water temperature. This is associated with the fact that fish need a fully oxygenated water when the oxygen-carrying capacity of the blood is reduced by the formation of methaemoglobin, and the oxygen requirement of fish increases with temperature.

Long exposure to sublethal concentrations of nitrites does not cause much damage to the fish. Concentrations corresponding to 20–40% of the minimum levels having a lethal action on the fish may slightly depress their growth but no serious damage has ever been recorded.

For estimating the safe nitrite concentration for particular locations, it is necessary to measure the ratio of chloride to nitrite. These ratios (expressed as $\text{mg l}^{-1} \text{Cl} : \text{mg l}^{-1} \text{N-NO}_2^-$) are recommended to be no less than 17 for rainbow trout and 8 for fish of low economic importance.

The toxicity of nitrates to fish is very low, and mortalities have only been recorded when concentrations have exceeded 1000 mg per litre; 80 mg per litre is considered to be the maximum admissible nitrate concentration for carp and 20 mg per litre for rainbow trout. In surface waters and in fish farms where the water contains ample oxygen with no danger of denitrification (i.e. conversion of NO_3^- to NO_2^- and then to elementary nitrogen or N_2O and NO), it is not so necessary to monitor the concentration of nitrates. However, as with ammonia, water quality standards need to be set for nitrate to prevent eutrophication, and the excessive growth of algae and plants, which can have a secondary effect on fish.

3.1.7 Hydrogen sulphide (H_2S)

Hydrogen sulphide occurs in organically polluted waters from the decomposition of proteins. It is also present in industrial effluents including those from metallurgical and chemical works, paper pulp plants, and tanneries. It has a high to very high toxicity to fish; the lethal concentrations for different fish species range from 0.4 mg H_2S per litre (salmonids) to 4 mg per litre (crucian carp, tench and eel). The toxicity of H_2S decreases with increasing water pH, because of a reduction in the ratio of the nondissociated toxic H_2S to the less toxic HS^- ions). The concentration of nondissociated H_2S can be calculated from the measured total hydrogen sulphide ($\text{HS}^- + \text{H}_2\text{S} + \text{S}^{2-}$) concentration and the pH value of the water, using the formula:

$$\text{H}_2\text{S} = (\text{HS}^- + \text{H}_2\text{S} + \text{S}^{2-}) \cdot p \frac{1}{10^{p\text{H}-7} + 1}$$

where p = activity coefficient depending on the ionic strength of water. For natural water it is about 0.92.

Hydrogen sulphide can be formed in decomposing rich organic mud, and escapes into the overlying water together with other gases (e.g. methane and carbon dioxide) formed by anaerobic degradation. In aerobic waters the H_2S is rapidly oxidized

to sulphate; however, it is possible for fish living close to the surface of such muds to be exposed to hydrogen sulphide.

3.1.8 Carbon dioxide

Carbon dioxide is dissolved in water in its molecular gaseous state; only 10 % is in the form of carbonic acid H_2CO_3 . These two forms of carbon dioxide together constitute what is termed free CO_2 . The ionic forms, i.e. fixed carbon dioxide, are represented by the bicarbonate and carbonate ions (HCO_3^- and CO_3^{2-} respectively). Their presence is important for the buffering capacity of the water. The amounts of CO_2 present in flowing surface waters are typically in the order of a few mg per litre, and seldom rise above 20 to 30 mg per litre. In stagnant surface waters the CO_2 levels are stratified because of photosynthetic assimilation by phytoplankton, the upper strata usually having less free CO_2 than the lower strata. If all the free CO_2 in the surface strata is used for photosynthesis, the pH of the water there may rise above 8.3, and in waters of moderate bicarbonate alkalinity to 10.0 and above during the daylight hours. Ground waters from limestone or chalk strata usually contain several tens of mg of free CO_2 per litre, and this may be important where well water is used for fish culture.

The toxic action of carbon dioxide is either direct or indirect. The indirect action of both free and bound CO_2 is exerted on fish through its influence on water pH, especially where, as described earlier, the values rise to toxic levels. Also, changes in pH affect the toxicity of those chemicals which exist in the dissociated and nondissociated forms of which only one is toxic, such as H_2S and ammonia.

A direct adverse effect occurs when there is an excess or absence of free CO_2 . In waters of low oxygen content, such as where intensive biodegradation is taking place, or where fish are kept or transported in a high density, or when poorly aerated ground waters are used, free CO_2 may reach harmful levels. In such cases the diffusion of CO_2 from the fish blood into the respiratory water is reduced, the blood CO_2 rises and acidosis develops. If the rise in CO_2 concentration is relatively slow (e.g. over 1 day), fish can adapt to the acidosis by increasing the bicarbonate concentration of the blood. Adapted fish can then suffer from alkalosis if returned to water of low CO_2 content.

In water of low O_2 and high CO_2 , where gaseous exchange at the respiratory surface is limited, the fish increase their ventilation rate, become restless, lose equilibrium, and may die. Twenty mg free CO_2 per litre is considered the maximum permissible concentration for trout (higher concentrations can cause kidney problems) and 25 mg free CO_2 per litre is the maximum for carp (if the acid capacity is 0.5 mmol per litre at a pH of up to 4.5). The sensitivity of fish to free carbon dioxide declines with increasing acid capacity of water.

However, the more frequent occurrence is a lack of free carbon dioxide in water. Carbon dioxide deficiency occurs when too much free CO_2 is utilized for photosynthetic activity by the phytoplankton, or when the water used in thermal power plants is artificially softened or when water is aerated more vigorously than necessary with CO_2 free air. Free carbon dioxide concentrations below 1 mg per litre affect the acid-base balance in the fish blood and tissues, and cause alkalosis. A lack of free carbon dioxide is particularly harmful to cyprinid fry when they pass from endogenous to exogenous nutrition. Cyprinid fry respire through their body surface and are unable to regulate their acid-base balance by gill respiration. A low partial pressure of free CO_2 in water is conducive to a high CO_2 diffusion rate from the body, leading to alkalosis and finally to death. If the fry of cyprinids suffer from free CO_2 deficiency, they gather close to the

water surface and show symptoms of suffocation even though the concentration of oxygen in the water is adequate (Taege, 1982).

3.1.9. Summary

The factors considered in this Chapter have been those which can occur in the natural environment, and which can be enhanced by man's activities. Fish have a limited ability to adapt to changes in these factors, if they occur sufficiently slowly; rapid changes can be harmful. If fish are affected to some extent by such changes, a full recovery is possible on return (in some cases, e.g. free CO₂, this needs to be gradual) to normal conditions. Unless irreparable damage has been caused to fish tissues, there are unlikely to be any long-term consequences to their health.

3.2 **Chemicals in water as a result of man's activities**

This section briefly describes the toxicity to fish of chemicals that are likely to occur in surface waters. Where possible, the acute toxic concentrations are given to provide information useful for cases of sporadic discharges where high concentrations may exist for a short time, and maximum admissible concentrations which are relevant for low-level continuous discharges. Clinical and patho-anatomic effects are also described. For more detailed information standard reference works should be consulted.

3.2.1 Chlorine

Active chlorine² can be discharged into water courses, lakes and ponds in effluents from textile and paper plants. Chlorine and compounds that release active chlorine into water are used as disinfectants in both public health and veterinary medicine. Thus, chlorine can be discharged in water from public swimming pools and from sterilizing procedures for equipment in dairy farms.

Chlorinated lime is used for a total disinfection of pond bottoms (application rate of 600 kg per ha), fish storage ponds and other facilities for fish culture and transport. If fish suffer from a gill disease, a recommended remedial procedure is to spread chlorinated lime on the surface of the pond at a rate of 10–15 kg per ha (if the average depth of the pond is 1 m). However, overdosage or improper handling of chlorine or chlorine-releasing compounds can damage or kill fish. Marketed fish may also be harmed by chlorine if retailers keep them in tanks supplied with chlorinated tapwater which contains 0.05 to 0.3 mg active chlorine per litre. Higher, rapidly lethal, concentrations can occur if the water supply works abstracts water containing a high content of organic matter; excessive chlorine then has to be used to disinfect the water. If chlorinated water from a public supply has to be used, it should be passed through an activated charcoal filter to remove the chlorine; for small-scale use, small amounts (c. 10 mg per litre) of sodium thiosulphate can be added to the water to react with the chlorine. Low concentrations of chlorine can be naturally absorbed by organic matter in the water and in sediments.

Active chlorine is very toxic to fish. Its toxicity largely depends on water temperature: for example, an active chlorine concentration of 3.5 mg per litre has a sublethal effect on carp at a water temperature of 3–7°C but when exposed to the same concentration at a temperature of 15–20°C they die in 1 to 2 hours. In general, a prolonged exposure to active chlorine concentrations of 0.04 to 0.2 mg per litre is considered to be toxic to the majority of fish species.

Active chlorine may affect specific parts of the fish (e.g. the skin and gills) or the whole body (i.e. when chlorine is absorbed into the blood). The systemic effect manifests

itself mainly as nervous disorders. The clinical symptoms of chlorine intoxication include a considerable restlessness, leaping out of the water, muscle tetanus, lying on one side, and spasmic movement of the mouth, fins and tail. The buccal spasms hinder respiration, so that the fish suffocate, and ultimately die. The skin and gills of the poisoned fish are covered with a thick layer of mucus and if the concentration of active chlorine is very high the gills become congested and can haemorrhage. The body surface of such fish becomes pale and the margins of the gill filaments and fins are covered with a grey-white coating. Histopathologically, there is a marked dystrophy and necrobiosis leading to necrosis, with desquamation of the gill respiratory epithelium and of the epidermis of the skin.

² Active chlorine includes all forms of chlorine which oxidize iodides into iodine in an acid medium (e.g. molecular chlorine, hypochlorites, chloramines, ClO₂).

3.2.2 Cyanides

Cyanides do not occur naturally in waters; they can be discharged in various industrial effluents, particularly from metal plating works and from the thermal processing of coal (e.g. for town gas production). Cyanides may be present in water either as simple compounds (nondissociated HCN, simple CN ions) or as complex compounds (e.g. complexes with iron, cobalt, nickel and other metals). Simple cyanides are very toxic or extremely toxic to fish species; lethal concentrations for the majority of species are in the range of 0.03 to 0.5 mg per litre. Cyanide toxicity is affected by the pH of the water; if the pH is low the proportion of nondissociated HCN increases and so does the toxicity (Table 2). Cyanide toxicity is also markedly enhanced by an increase in water temperature and a decrease in the concentration of dissolved oxygen in the water.

With complex cyanides, the toxicity varies according to their ability to dissociate into metal and HCN. For example, the complex iron cyanides which do not dissociate are of low to very low toxicity to fish but the complex cyanides of zinc, cadmium, copper and mercury which do are highly toxic. The concentrations of different cyanide compounds proposed as maximum admissible levels for fish culture are in the range of 0.002 to 0.02 mg per litre.

The mechanism of the toxic action of cyanides is based on their inhibition of respiratory enzymes (i.e. cytochromoxidases). This blocks the transfer of oxygen from the blood to the tissues, reduces tissue respiration and leads to tissue asphyxia. The clinical symptoms of the cyanide poisoning of fish include increased depth of respiration, nervous disorders, and loss of equilibrium. If the fish are transferred to clean water while they are in the early stages of overturning, they will recover in 1 to 2 hours. The characteristic features of the patho-anatomic examination in cases of cyanide poisoning include a cherry-red colour of the gills and sometimes also leakage of tissue fluid mixed with blood into the body cavity.

Table 2: The dependence of HCN content (% of simple cyanide content) on water pH

pH	% HCN	% CN
6	100	0
natural	100	0
range 7	93	7
8	60	40
9	10	90
10	2	98
11		

3.2.3 Divalent metals and their salts

Trace quantities of metals present in waters may be of natural origin. If waters are polluted with metals at greater concentrations, the source may be traced back to ore mining and processing, to smelting plants, rolling mills plants for the surface treatment of metals, film, textile and leather industries and other sources. Atmospheric precipitation can wash out metals in dust and aerosols generated by the burning of fossil fuels, by the exhaust gases of motor vehicles, and from other sources.

The mechanism of the toxic action of metals on fish is varied. Most of the metals have a great affinity for amino acids and the SH groups of proteins: as such, they act as enzyme poisons. The toxicity of metals to fish is significantly affected by the form in which they occur in water. The ionic forms of metals or simple inorganic compounds are more toxic than complex inorganic or organic compounds. The toxic action of metals is particularly pronounced in the early stages of development of the fish.

Another potentially harmful property of many metals is their ability to accumulate in the sediments and in the aquatic flora and fauna (bioaccumulation). This property is quantitatively described by the accumulation coefficient (concentration in substrate/ concentration in water) and such values can range from several hundred to many thousands; mercury, selenium and cadmium have a particularly high bioaccumulation capacity. Hence, the concentration of these metals in water does not provide a true indication of the total pollution of the aquatic medium; it is better to use the content of metals in the sediments, and especially also in the bodies of predatory fish which are the final link in the food chain, as an indicator.

The metals found to be of highest importance to fisheries in practice include aluminium, chromium, iron, nickel, copper, zinc, arsenic, cadmium, mercury and lead.

3.2.3.1 Aluminium

The toxicity of aluminium to fish depends to a large extent on the physico-chemical properties of the water and particularly on its pH. Aluminium is soluble at pH values below 6.0; a number of chemical species can be formed, the most toxic occurring in the pH range of 5.2 to 5.8. At higher pH values, aluminium is precipitated as the hydroxide, which can flocculate in the water. It is possible that freshly precipitated aluminium (as a colloid) may be toxic; the fully flocculated hydroxide has a low toxicity similar to that of suspended solids in general.

In toxicity tests, rainbow trout fry were exposed to different aluminium concentrations at a pH of 7.0. A concentration as low as 0.52 mg aluminium per litre was found to markedly reduce the growth of these fish. When an even lower concentration, 0.05 mg per litre, was tested no such adverse effect was found, so this concentration can be regarded as safe at this pH. A mass kill of maraena and peled fry, reared in a public supply water clarified by flocculated aluminium sulphate, is a practical example. The aluminium concentration of the water was up to 0.3 mg per litre and the pH value was between 7.0 and 7.5. All the fry of maraena and peled died within 10–14 days of hatching. It is not known whether this was due to ionic aluminium or to micro flocs affecting fish respiration.

3.2.3.2 Chromium

In surface waters, the most stable forms of chromium are the oxidation states III and VI. Of these two forms, chromium III is poorly soluble and is readily adsorbed onto surfaces, so that the much more soluble chromium VI is the most common form in fresh

water. For this reason, maximum admissible concentrations for chromium are generally based on toxicity data for the hexavalent form.

Chromium compounds in the trivalent state (III) are more toxic to fish and other aquatic organisms than are those in the hexavalent state VI. From the LC50 data obtained for different fish species, chromium III compounds are among those substances with a high toxicity to fish (LC50s of 2.0 to 7.5 mg per litre) whereas chromium VI compounds are among those substances of medium toxicity (LC50s of 35 to 75 mg per litre). The toxicity of chromium compounds to fish is also considerably affected by the physico-chemical properties of water, especially the pH value and the concentrations of calcium and magnesium. At a high pH and a high concentration of calcium, the toxicity of chromium to aquatic organisms is reduced, compared to that in soft acid water. With acute poisoning by chromium compounds, the body surface of the fish is covered with mucus, the respiratory epithelium of the gills is damaged and the fish die with symptoms of suffocation. Fish suffering from chronic chromium intoxication accumulate an orange yellow liquid in their body cavity.

3.2.3.3 Iron

In surface waters, iron occurs in ferrous state II (soluble compounds) or ferric state III (mostly insoluble compounds). The ratio of these two forms of iron depends on the oxygen concentration in the water, the pH and on other chemical properties of the water. Fish may be harmed by iron compounds in poorly oxygenated waters with a low pH where the iron is present mainly in the form of soluble compounds. Because the gill surface of the fish tends to be alkaline, soluble ferrous iron can be oxidized to insoluble ferric compounds which then cover the gill lamellae and inhibit respiration. At a low water temperature and in the presence of iron, iron-depositing bacteria will multiply rapidly on the gills and further contribute to the oxidation of ferrous iron compounds. Their filamentous colonies cover the gills; at first they are colourless but later the precipitated iron gives them a brown colour. The precipitated iron compounds and tufts of the iron bacteria reduce the gill area available for respiration, damage the respiratory epithelium and may thus suffocate the fish. In a similar toxic action, iron compounds can precipitate on the surface of fish eggs which then die due to a lack of oxygen.

The lethal concentration of iron for fish is not easy to measure because it depends to a large extent on the physico-chemical properties of the water. In cyprinid culture, it is generally accepted that the concentration of the soluble ionized forms of iron should not exceed 0.2 mg per litre; for salmonids this limit is 0.1 mg per litre.

3.2.3.4 Nickel

Nickel can be discharged into surface waters in effluents from metal plating plants. Nickel compounds are of medium toxicity to fish. With short periods of exposure, the lethal concentration is between 30 and 75 mg per litre. As with the toxicity of other metals, the toxicity of nickel compounds to aquatic organisms is markedly influenced by the physico-chemical properties of water. For example, in soft waters with low calcium concentrations, the lethal concentrations of nickel compounds for the stickleback were less than 10 mg per litre. In such cases nickel can be regarded as highly toxic to fish. After toxic exposure to nickel compounds, the gill chambers of the fish are filled with mucus and the lamellae are dark red in colour.

3.2.3.5 Copper

Although copper is highly toxic to fish, its compounds are used in fish culture and fisheries as algicides and in the prevention and therapy of some fish diseases. The physical and chemical properties of the water exert a strong influence on the toxicity of copper to fish. In water containing high concentrations of organic substances copper can become bound into soluble and insoluble complexes. In very alkaline water it forms hydroxides of low solubility, and in waters with a high bicarbonate/carbonate concentration copper precipitates as poorly soluble or insoluble cupric carbonate. Compounds that are slow to dissolve or are insoluble are unlikely to be taken up to any extent into the fish body, so their toxicity to fish is low. A good example of this effect of solubility is a comparison between the different LC50s for carp recorded during 48 hours exposure to $\text{CuSO}_4 \cdot 5\text{H}_2\text{O}$ in a pond water [pH 7.6; acid capacity to a pH of 4.5 (a measure of bicarbonate alkalinity), 2.2 mmol per litre; COD_{Mn} 32 mg O_2 per litre] and in a well water [pH 6.2; acid capacity to a pH of 4.5, 0.6 mmol per litre; COD_{Mn} 2.2 mg O_2 per litre]: in the hard pond water the LC50 was 8.1 mg per litre and in the softer well water it was 1.5 mg per litre.

The maximum admissible copper concentration in water for the protection of fish is in the range of 0.001 to 0.01 mg per litre, depending on the physical and chemical properties of water and on the species of the fish. The characteristic clinical symptoms of fish poisoned by copper ions and copper compounds include laboured breathing and, in cyprinids, gasping for air at the water surface. The typical patho-anatomic appearance includes a large amount of mucus on body surface, under the gill covers and in the gills. Acute copper intoxication can be diagnosed on the basis of a chemical analysis of the gills in which the concentration of copper is much greater than in other parts of the body of the fish. The gills of fish caught in waters free of copper contamination contain up to 10 mg of copper per 1 kg of dry matter.

3.2.3.6 Zinc

Zinc poisoning of fish is most frequently encountered in trout culture. Rainbow trout and brown trout, and especially their fry, are extremely sensitive to zinc and its compounds. The lethal concentrations are around 0.1 mg per litre for salmonids (some authors even suggest a level of 0.01 mg per litre) and 0.5 to 1.0 mg per litre for cyprinids. Resistance to zinc compounds increases with age. The toxicity of zinc to fish is influenced by the chemical characteristics of water; in particular, increasing calcium concentrations reduce the toxicity of zinc. The clinical symptoms and patho-anatomic picture of zinc poisoning in fish are similar to those found for copper. The best remedy to avoid frequent occurrences of zinc toxicity in trout culture is to avoid using galvanized pipes for the supply of water and to avoid using galvanized containers and equipment, especially in areas where the water is soft and acid.

3.2.3.7 Arsenic

As a rule arsenic occurs in water in the oxidation state V but some of it may also be present in non-stable forms, i.e. in the oxidation state III. As with mercury (see later) biological (particularly bacterial) activity may lead to the formation of organic methyl derivatives of arsenic. The main sources of arsenic pollution in surface waters include industrial effluents e.g. from tanneries, ore processing plants and dyestuff production plants. Arsenic is able to accumulate in large quantities in the sediments on the bed of water courses and reservoirs, and in aquatic organisms. Arsenic compounds in the third oxidation state (arsenites) are absorbed fairly rapidly into fish and are more toxic than

arsenic compounds in the oxidation state V (arsenates). From concentrations found to be lethal to different species of fish during 48 hours of exposure, diarsenic trioxide, for example, can be included among those substances which have a medium to high toxicity to fish; lethal concentrations are between 3 and 30 mg per litre.

3.2.3.8 Cadmium

Cadmium in surface waters is usually found together with zinc but at much lower concentrations. The cadmium present in surface waters may be either dissolved or insoluble. Of the dissolved forms, those which may be poisonous to fish include the simple ion and various inorganic and organic complex ions. Apart from an acute toxic action which is similar to that of other toxic metals (damage to the central nervous system and parenchymatous organs), very small concentrations of cadmium may produce specific effects after a long exposure period. Chief among these specific effects are those exerted on the reproductive organs. An adverse influence of long exposure to cadmium upon the maturation, hatchability and development of larvae in rainbow trout was recorded at concentrations as low as 0.002 mg l⁻¹. The acute lethal concentration of cadmium for different species of fish is from 2 to 20 mg l⁻¹. Cadmium toxicity is reduced with increasing levels of calcium and magnesium in the water. For salmonids, the maximum admissible cadmium concentration in water is 0.0002 mg per litre, and for cyprinids 0.001 mg per litre (Schreckenbach, 1982).

3.2.3.9 Mercury

Mercury is transported to the aquatic environment mainly in discharges of industrial effluents and by atmospheric precipitation. Unpolluted waters will contain trace amounts of mercury which do not exceed 0.1 µg per litre.

Mercury concentrations found in surface waters are not a true measure of the actual total amount of mercury present and therefore do not represent the extent of the mercury pollution there; this is because mercury is transferred from water to the sediments on the bed of water courses, lakes and reservoirs where it accumulates mainly as the sulphide. Elementary mercury and its organic and inorganic compounds can undergo methylation (a process induced by the activity of microorganisms) in the sediments. The toxic end-product of this methylation, methyl mercury, enters the food chains and bioconcentrates in increasing amounts in aquatic organisms up the food chain.

Mercury can be taken up into fish from food via the alimentary tract; the other routes are through the gills and skin. Absorption from the alimentary tract has proved to be of the greatest importance in methyl mercury accumulation; evidence for this has been provided by the results of investigation at sites in the drainage area of the Berounka River in Central Bohemia. The total mercury content in the flesh of fish from these localities is about 10 times that recorded in their food. This coefficient of bioaccumulation can be compared with the food efficiency coefficient of fish living in open waters and feeding on the aquatic invertebrates. Of the other aquatic organisms in the drainage area of the Berounka River, the greatest mercury levels were recorded in leeches and this can be ascribed to their exclusively predatory mode of feeding. With their wide distribution in different types of waters, leeches (e.g. *Helobdella stagnalis*) may be considered as good indicators of mercury contamination of the aquatic medium.

Carnivorous fish contain the highest amounts of mercury because they form the final link in the aquatic food chain. The problem of mercury in the aquatic medium is important not only for environmental and hygienic reasons but also from the viewpoint of

fish culture. It has been shown that mercury compounds can cause damage to some vital tissues and organs in fish and may also have a harmful effect on reproduction. At very low concentrations they reduce the viability of spermatozoa, reduce egg production and affect the survival rate of developing eggs and fry. Acute lethal concentrations of inorganic mercury compounds are in the range of 0.3 to 1.0 mg per litre for salmonids and 0.2 to 4.0 mg per litre for cyprinids, depending on the physical and chemical properties of the water. The acute lethal concentrations of commonly found organic mercury compounds are from 0.025 to 0.125 mg per litre for salmonids and from 0.20 to 0.70 mg per litre for cyprinids. For salmonids the maximum admissible concentration of inorganic forms is about 0.001 mg per litre and for cyprinids about 0.002 mg per litre. For fish in general, the maximum admissible concentration of mercury in organic compounds has been suggested to be as low as 0.0003 mg per litre.

3.2.3.10 Lead

A significant source of airborne lead contamination, and therefore of surface waters, is the exhaust fumes of motor vehicles which contain the break-down product of tetraethyl lead. In surface waters, lead largely accumulates in bottom sediments at concentrations about four orders of magnitude greater than in the water.

Lead toxicity to fish and other aquatic organisms is significantly influenced by the water quality and depends on the solubility of lead compounds and on the concentration of calcium and magnesium in water. The water solubility of lead compounds is reduced with increasing alkalinity and pH value of the water. Also, the toxicity of lead is known to be reduced with increasing calcium and magnesium concentrations in water. The acute toxic concentrations in different types of water are in the range of 1 to 10 mg per litre for salmonids and of 10 to 100 mg per litre for cyprinids.

Acute lead toxicity is characterized initially by damage to the gill epithelium; the affected fish are killed by suffocation. The characteristic symptoms of chronic lead toxicity include changes in the blood parameters with severe damage to the erythrocytes and leucocytes, and degenerative changes in the parenchymatous organs and damage to the nervous system. In trout, a characteristic symptom is a blackening of the caudal peduncle; a biochemical effect is the inhibition of amino levulinic acid dehydrase (ALA-D) in fish blood. The maximum admissible lead concentration in water is 0.004 to 0.008 mg per litre for salmonids and 0.07 mg per litre for cyprinids.

3.2.4 Phenols

Phenols occur in surface waters from discharges of industrial effluents, especially from the thermal processing of coal, from petroleum refineries, and from the production of synthetic fabrics. Phenols are either monobasic (e.g. phenol, cresol, naphthol, xylenol) or polybasic (e.g. pyrocatechol, resorcine, hydroquinone, pyrogallol, floroglucin).

Phenols can give an unacceptable taint to water and fish, especially chlorophenols which are formed from the chlorination of phenols. The maximum concentrations admissible for fish culture are 0.001 mg per litre for chlorophenol, 0.003 mg per litre for cresol, 0.004 mg per litre for resorcine, and 0.001 mg per litre for hydroquinone. Concentrations of 0.1 mg of phenols per litre of water and 0.02 mg of chlorophenols per litre of water are high enough to cause changes in the flavour of fish flesh. Prolonged exposure to a concentration of 0.2 mg of phenols per litre of water was observed to cause fish to migrate out of the catchment area of a polluted watercourse. Based on the lethal concentrations for fish, the different phenol compounds can be ranked as follows: hydroquinone (0.2 mg per litre), naphthols (2 to 4 mg per litre),

phenol, cresol, pyrocatechol and xylenol (2 to 20 mg per litre), resorcine and pyrogallol (10 to 50 mg per litre), floroglucin (400 to 600 mg per litre).

Phenols are anaesthetics which affect the central nervous system. The clinical signs of intoxication are characterized by increased activity and irritability, leaping out of the water, loss of balance and muscular spasms.

The post-mortem appearance include a conspicuous whitening of the skin which is heavily coated with mucus; at high temperature this may be accompanied by haemorrhages on the under side of the body. Long exposure to low concentrations leads to dystrophic to necrobiotic changes in the brain, parenchymatous organs, circulation system and gills.

3.2.5 Polychlorinated biphenyls (PCBs)

Polychlorinated biphenyls are recognized as very important environmental pollutants. PCBs are among the most environmentally persistent of organic compounds; although their solubility in water is very low, they are readily soluble in nonpolar solvents and can accumulate in fats. Mixtures of a large number of PCBs isomers are used in the heavy electrical equipment industry (e.g. in power capacitors and high-voltage transformers), mechanical engineering (e.g. as inflammable liquids for heat transfer, in hydraulic fluids and in lubricants for compressors) and in the chemical industry (e.g. the production of synthetic varnishes, dyestuffs and plastics). The world-wide trade names of PCBs include Delor (Czechoslovakia), Aroclor (USA), Clophen (Germany), Kaneclor (Japan), and Savol and Sovtol (USSR). In response to a growing concern about rising levels of PCBs in the environment from diffuse sources, their accumulation in biota, and uncertainty about their toxic effects, the production of polychlorinated biphenyls was restricted in 1971, and successive controls placed on its use and disposal. The main concern is that, once in the natural environment, they cannot be recovered or removed.

In surface waters, PCBs occur at concentrations from $1 \cdot 10^8$ to $1 \cdot 10^4$ mg per litre. Polychlorinated biphenyls have a high capacity for accumulation in the bottom sediments and in aquatic organisms for which the bioaccumulation coefficient is from 10^3 to 10^5 , depending on the fat content.

PCBs present a very difficult ecotoxicological problem; there are 209 individual PCBs, each one with different toxicological properties. Toxicity tests are carried out on commercial formulations which are identified by the extent to which they are chlorinated, and not by the specific PCBs that they contain. This makes it difficult to assess their toxicity in the environment, because differential uptake of the individual compounds leads to a different ratio being found in organisms when compared to that in the tested formulations. Therefore, any assessment of the toxicity of PCBs can be made only in general terms on the basis of tests with commonly used formulations.

PCB formulations are very toxic to extremely toxic to fish, especially in their early developmental stages; their 48 hour LC50s are below 1 mg per litre.

Of the various toxic actions of PCBs reported, they have been found to adversely affect the enzyme systems within the microsomal fraction of the liver. If fish are exposed for a long time to low sublethal PCBs levels, the compounds accumulate in the body and can cause, mainly in the fry, deformities in the skeleton, damage to the skin and fins (the fins disintegrate), to the parenchymatous organs (mainly in the liver where hypertrophy, local dystrophy, and necrobiotic to necrotic changes can occur), and to the gonads. These effects can cause a subsequent mortality during hatching, high mortality of early fry and an increased occurrence of different deformities among the survivors.

The maximum admissible PCBs concentrations in water range from $1 \cdot 10^{-6}$ to $5 \cdot 10^{-6}$ mg per litre for salmonids and from $2 \cdot 10^{-6}$ to $1 \cdot 10^{-5}$ mg per litre for cyprinids (Mattheis et al., 1984). Lower admissible concentrations are recommended during hatching and rearing of the early stages of the fry. However, analytical measurement of these concentrations in solution may be difficult; also, a significant proportion of the uptake of PCBs will be from the food. Analysis of fish tissue will give an indication of the degree of exposure, but the concentrations found must be correlated with the tissue fat content. Where significant amounts occur, the analysis should identify and quantify a number of key individual PCBs for an expert evaluation of the potential hazard.

3.2.6 Surfactants

Surfactants are compounds which, by lowering the surface tension of water, can facilitate the formation of emulsions with otherwise immiscible liquids such as oils and fat. They are widely used domestically and in industry. In recent years, the traditional soaps have been replaced by detergents that contain synthetic surfactants and other ingredients; for domestic washing of garments, these may contain water softeners, optical brighteners, and perfumes.

Surfactants are either ionic (liable to electrolytic dissociation) or nonionic (nodissociating in water). Ionic surfactants are subdivided into anionic (dissociating to a surface active anion and an inactive cation), cationic (dissociating to a surface active cation and an inactive anion), and ampholytic (assuming either anionic or cationic properties, depending on ambient conditions). The anionic surfactants are those most widely used in industry.

Because of the large number of synthetic surfactants in production, it is not surprising that they span a wide range of chemical toxic actions for aquatic organisms. However, they do have a common physico-chemical effect in that they can damage the lipid components of cell membranes. Because the surface tension of the ambient water is decreased, the lipids are less water repellent and this leads to hydration and enlargement of the cell volume. At low surfactant concentrations this enlargement is reversible. Higher concentration can cause a suppression of metabolic processes in the cells. Long-term exposure may damage the cells which then become necrotic in the later stages. These changes result mainly in an impairment of the gill respiratory epithelium. In addition, the exposure of fish to some surfactants can cause changes in the activity of respiratory enzymes, especially cytochromoxidase. Surfactants can also damage the protective layer of mucus on the skin; the layer loosens and the resistance of the fish to infection decreases. Sublethal surfactant concentrations can also damage eggs and sperm.

The toxicity of surfactants to fish is influenced by a number of biotic and, especially, abiotic factors. The age of the fish is a particularly important biotic factor.

During embryonic and larval development, the sensitivity of fish to surfactants is sometimes greater by an order of magnitude in comparison with the juvenile and adult stages. Of the abiotic factors, the molecular structure of the surfactant and the physico-chemical properties of water exert the greatest influence on their toxicity. The results of investigations into the relationship between toxicity and molecular structure indicate, for example with linear alkylbenzene sulphonates, that the toxicity to fish is markedly increased with the length of the molecular chain. A similar correlation between toxicity and chain length was observed with other surfactants. Among the physico-chemical properties of water, increasing calcium and magnesium concentrations have the greatest effect on reducing surfactant toxicity and some influence is also exerted by the pH. This

may be important where surfactants are incorporated into a detergent containing water softening chemicals (e.g. polyphosphates). Where both cationic and anionic surfactants are present in waste waters their toxicity is much reduced, due to the formation of insoluble complex.

The acute toxicity of surfactants varies considerably with the species of fish. Nevertheless, these compounds and the detergents that contain them are highly toxic to fish in the majority of cases, the 48-hour LC50 ranging between 1 and 10 mg per litre. A small proportion of surfactants can be classified as having a medium toxicity (48-hour LC50 between 10 and 100 mg per litre) and a few have a very low toxicity (48-hour LC50 to 10 000 mg per litre). For the majority of surfactants, no significant differences in their toxicity to fish were recorded between the anionic, cationic and nonionic groups.

As stated above, surfactants can cause damage to the gill respiration epithelium (e.g. enlargement and vacuolation of the cells with dystrophic to necrobiotic changes). Therefore, the clinical signs of poisoning include respiratory disorders (increased respiration rate, and cyprinids gasp for air at the water surface) and later by inactivity. The characteristics in the patho-anatomic examination are an increased amount of mucus on the skin and in the gills, and congestion to oedematous swelling of the gill apparatus. The mucus is easily removed from the body surface and gills.

3.2.7 Pesticides

In recent years, the number of pesticides available and the quantity used has considerably increased. The term "pesticide" is used to include insecticides, acaricides, herbicides, fungicides and algicides, indeed any chemical which is used to control an unwanted organism (except bacteria), even rotenone which is used to kill unwanted fish. Pesticides are chemicals which have a specific toxic action to which the pest species is particularly sensitive. The chemical is then applied at a concentration which kills the pest but does not affect a wide range of non-target organisms. The ideal pesticide is a chemical which is extremely pest-specific; for the pesticide user it should also be persistent in order to avoid the need for repeated applications. However, on environmental grounds, pesticides should be non-persistent to avoid concentrations building up in environmental compartments and causing unsuspected side-effects. For example, the insecticide DDT is very persistent and thus can build up in food chains to ultimately affect the egg-shell thickness of birds of prey.

Because pesticides are designed and used to kill living organisms, and because of the possibility of unsuspected side effects, it is tempting to implicate them in any incident of fish poisoning where there is no other obvious cause of the damage. There are many cases, therefore, where pesticides have been assumed to be the cause of damage but where the real cause was some other factor.

Some cases of pesticide poisoning of fish are obvious; accidental discharges from road accidents, factory disasters, overspraying of water, or careless disposal of unwanted spray and pesticide containers, can be clearly identified as causes of mortality, especially if the concentrations measured or calculated in the water exceed the 96 hour LC50 by a significant margin. Less easily identified are cases of long-term leaching of persistent pesticides from fields and forests. Besides these acute and chronic direct effects, an indirect action may be important. Inexpert application of aquatic herbicides or algicides to the water, or the accidental contamination of surface waters with these chemicals, may kill excessive quantities of aquatic plants and algae. The rapid decomposition of this organic matter forms a considerable dissolved oxygen

demand on the water. This will lead to an oxygen deficit and the fish may die of suffocation.

Another potentially serious indirect consequence of pesticide contamination of the aquatic biota is the reduction or complete destruction of the natural food supply of the fish. Many of the organisms on which the fish feed are much more sensitive, particularly to insecticides, than the fish themselves. For example, the LC₅₀ for the organo-phosphorus insecticide formulation "Soldep" (active ingredient 25% trichlorphon) for common carp is 545 mg per litre of water whereas for *Daphnia magna* it is 0.0002 to 0.001 mg per litre.

Besides the active ingredient, pesticide formulations contain a number of other chemicals which may sometimes be much more toxic to fish than the active ingredient itself.

When a pesticide enters the aquatic environment, the active ingredient may undergo chemical and biological degradation. In some cases the degradation products may be more toxic to fish than the original active ingredient. For example, parathion is biodegraded to form paraoxon, which is a more toxic compound; similarly, trichlorphon is degraded to form the more toxic compound dichlorvos. It follows that the absence of a specific active ingredient in water cannot guarantee that harmful degradation products are not present.

Some herbicides are used in fish culture and water management to kill unwanted aquatic plants (e.g. Gramoxone S, Reglone). Trichlorphon based organo-phosphorus insecticides, e.g. Soldep, Masoten, Neguvon, etc. are used to reduce the larger *Daphnia* in the zooplankton to prevent an oxygen deficit in the pond, to kill predatory cyclopids before stocking the pond with fish at the sac fry stage, to control parasites that infest cyprinids, and for other management purposes. Pesticides based on copper oxychloride may be used to control fish parasites, including the control of gastropod intermediate hosts, and to kill excessive growths of algae.

However, in the majority of cases pesticides have the potential to cause damage to fish. The most toxic pesticides are those based on chlorohydrocarbons (e.g. DDT, dieldrin), organo-phosphorus compounds, carbamates and thiocarbamates, carboxylic acid derivatives, substituted urea, triazines and diazines, synthetic pyrethroids, and metallic compounds.

3.2.7.1 Chlorohydrocarbon (i.e. organochlorine) pesticides

These pesticides act as nerve poisons. They are highly to extremely toxic to fish (48-hour LC₅₀ < 1.0 mg per litre). Because of their chemical structure and their persistence, their use is now strictly controlled or banned.

The clinical signs of fish poisoning by organochlorine pesticides on the basis of chlorohydrocarbons include increased activity, followed by a long stage of reduced activity. There is no specific patho-anatomic picture in these cases of intoxication; dystrophic alterations have been recorded in the liver and kidneys.

3.2.7.2 Organo-phosphorus pesticides

The mechanism of the toxic action of organo-phosphorus pesticides on fish follows the same pattern as their action on homoiothermic animals, in that some hydrolytic enzymes, particularly acetylcholine hydrolase, are inhibited. The degree of inhibition of cerebral acetylcholine hydrolase in fish varies with the specific organo-phosphorus compound causing the effect. Phenitrothion-based pesticides reduce the

enzyme activity to 60%, dichlorvos- and imidane-based pesticides cause a greater reduction which leaves only 22% of the physiological activity remaining. The toxicity of these pesticide formulations to fish also varies; from the 48h LC50s obtained they are ranked among those substances of very high to medium toxicity to fish (0.1–100 mg per litre). Also, salmonids are very sensitive to organo-phosphorus pesticides. The typical sign of fish poisoning with these pesticides is a darkening of the body surface at the onset of uncoordinated activity. The patho-anatomic picture of such poisoning is characterized by a considerable mucus production on the body surface and in the gills, a heavy congestion of the gills, and small isolated (“spotted”) haemorrhages in the gills when the pesticide concentration is high.

The water flea (*Daphnia magna*) is very sensitive to organo-phosphorus pesticides; from the 48h LC50s obtained for these substances, they can be classified as extremely toxic. It is interesting to note that the water flea was found to be sensitive to trichlorphon and dichlorvos at concentrations close to the level of detection by gas-liquid chromatography. *Daphnia magna* can be regarded, therefore as a sensitive indicator of organophosphorus pesticide pollution.

3.2.7.3 Carbamate and thiocarbamate pesticides

Carbamate and thiocarbamate compounds also inhibit the activity of acetylcholine hydrolase. However, unlike the toxic action of organo-phosphorus compounds, the inhibition of enzyme activity is readily reversed after carbamate and thiocarbamate poisoning. The toxicity levels of these substances to fish vary from very high to low toxicity (48h LC50s in the range of 1 to 1000 mg per litre). The clinical and patho-anatomic pictures of fish poisoning by these pesticides are not specific.

3.2.7.4 Pesticides based on carboxylic acid derivatives

A number of these pesticides are based on phenoxyacetic acid; the main representative of this group is 2-methyl-4-chlorphenoxyacetic acid (MCPA). Most of the MCPA-based products are of medium to low toxicity to fish (48h LC50s in the range of 10 to 1000 mg per litre). The clinical signs of poisoning are mostly characterized by increasing narcosis. There is no marked patho-anatomic picture in fish poisoned by these herbicides.

3.2.7.5 Pesticides based on substituted urea

Herbicides formulated from substituted ureas are of high to low toxicity to fish (48h LC50s are in the range of 1 to 1000 mg per litre). The clinical symptoms of poisoning are not specific and include increased activity, irregular respiration, uncoordinated movement and a long period of “distress”. The patho-anatomic picture is characterized by an increased amount of mucus on the darkened body surface, hyperaemia of the gills and the presence of a small amount of exuded fluid in the body cavity of the fish.

3.2.7.6 Diazine and triazine pesticides

Triazine-based pesticides are of high to medium toxicity to fish (48h LC50s range from 1 to 100 mg per litre). The clinical signs of fish poisoning by these chemicals are largely characterized by progressive narcosis. The presence of exuded fluid into the body cavity and into the digestive tract is an especially characteristic patho-anatomic sign, particularly in rainbow trout. The presence of exudates causes a marked swelling of the body cavity; in rainbow trout it has even led to a rupture of the body wall in some cases.

Diazine-based herbicidal preparations are less toxic to fish than are triazine-based preparations. Most of the former are of low to very low toxicity to fish (48h LC50 ranging from 100 to 10 000 mg per litre). The clinical course of intoxication is characterized by stages of immobility. The patho-anatomic picture is not specific to these compounds.

3.2.7.7 Synthetic pyrethroid pesticides

The 48h LC50s of these pesticides show that they rank among those substances of high toxicity (up to 10 mg per litre) to extreme toxicity (less than 0.1 mg per litre) to fish. The clinical signs of poisoning are not specific and include respiratory disorders. The most conspicuous patho-anatomic change is the presence of a small amount of exuded fluid in the body cavity.

3.2.7.8 Pesticides based on metal compounds

These include primarily the fungicides formulated from compounds containing copper, mercury and aluminium. In the majority of cases, their toxicity to fish and the clinical and patho-anatomic symptoms correspond to those found in fish poisoned by the respective metals.

3.2.8 Oils and refined products

Oils and refined products have been responsible for many of the recently recorded pollution incidents in surface and underground waters. Between 1970 to 1990 these substances were responsible for the majority of water pollution accidents recorded on a worldwide basis. These accidents were not associated with problems in sewage treatment plants; most of them were due to careless storage and handling of oil, transport accidents, and defective equipment, all of which can be ascribed either directly or indirectly to human error.

However, oils and refined products can also be discharged into the aquatic environment with industrial effluents. The petrochemical industry is mainly responsible for such effluents; other important sources of pollution include the engineering and metallurgical industry and car and truck repair and service stations. Most of these sources have discharged polluting effluents for many years. To some extent, the large number of reported oil-related pollution incidents is due to the very visible surface film that is formed; it therefore needs no chemical analysis for its detection. Even very small discharges can produce a large area of "sheen" in which the thickness of the oil is about 1 micron. For this reason, few discharges of oil go unnoticed. The harmful effects of such discharges depend on the physical effects of the surface film, and on the transfer of water soluble products into the water.

However, few of the constituent of oil and refined oil products will readily dissolve in water. There are also large differences between oil and its different products as to their toxicity to fish; most of them have 48h LC50 values within the range of 0.5 to 200 mg per litre. The toxicity varies according to the chemical composition of the different products, with the water solubility of the different petroleum hydrocarbons, and with the degree of emulsification of insoluble components in the water. It is generally agreed that the lighter oil fractions (including kerosene, petrol, benzene, toluene and xylene) are much more toxic to fish than the heavy fractions (heavy paraffins and tars). There are also differences in the sensitivity to oils and refined products between different fish species. The fry of predatory fishes (especially pikeperch and trout) show the greatest sensitivity to refined products.

When oils are discharged to rivers or ponds they spread on the surface, thus reducing (especially in stagnant waters) the transfer of oxygen from the air to water. In cases of pollution of flowing turbulent waters the oil does not form an intact layer on the water surface but becomes dispersed as droplets into the water. In such cases, the gills of fish can become mechanically contaminated and their respiratory capacity reduced. Oil products may contain various highly toxic substances, such as benzene, toluene and xylene which are to some extent soluble in water; these penetrate into the fish and can have a direct toxic effect. These toxic components include the naphthenic acids which are acute nerve poisons and are able to kill fish at concentrations as low as 0.03 to 0.1 mg per litre.

In general, oils and most of the refined products have a narcotic effect on fish; acute symptoms are effects on the nervous system and respiratory activity. The main clinical symptoms include an initial increased activity and respiratory rate followed by a loss of balance (the fish lie on their side), loss of response to stimuli, reduced activity, shallow respiratory movements, and ultimately death.

The scales of the dead fish are dull in colour and are covered with mucus; the skin shows local congestion, the epidermis fractures and peels off, and surface wounds may occur in some cases. Damage to the cornea of the eyes may lead to blindness. The gills show severe dystrophic effects and necrosis and there may also be a proliferation of the respiratory epithelial cells and hypertrophy of the mucus cells. Prolonged exposure to oils at low concentrations can cause severe degenerative necrobiotic effects in the kidneys of the fish and in their eggs. The dead fish have an oily odour and flavour.

Therefore toxicity is not the only harmful consequence associated with oil pollution; the aquatic ecosystem in general, and fish farming in particular, can be badly affected by the oily smell and taint of the water and of the organisms living there. For this reason, a sensory assessment is preferred to toxicological analyses in determining the highest admissible amounts of oil and oil products that can be present in water; on this basis the highest admissible concentrations are in the range of 0.002 to 0.025 mg per litre.

3.2.9 Dyes

Chemical dyestuffs have also been attracting the attention of toxicologists in recent years. These can be present in the effluents from textile production, food processing and paper mills. Although these coloured effluents are, like oils, very conspicuous even at very great dilutions they seldom cause severe damage to the fish. The toxicity of dyes depends on the physico-chemical composition of the water; in water containing considerable amounts of organic matter the dyes are bound to these substances and their toxicity is decreased.

The mechanism of toxic action of effluents containing dyestuffs on fish is not direct in the majority of cases. If the water is heavily polluted with coloured organic waste, the increase in the organic content alone can lead to an oxygen deficit. Other dyes may increase or decrease the water pH. Some, e.g. aniline, can act as methaemoglobin poisons and as carcinogenic substances.

There is a considerable variation in the acute toxicity of different dyestuffs to fish. Most of the dyes rank among those substances of low to very low toxicity to fish (48h LC50s in the range of 100 to 10 000 mg per litre). This group includes colouring agents used in the food industry and selected organic dyestuffs. Another group, including e.g. acriflavine, rhodamine and also aniline and to a lesser extent methylene blue, are

substances of medium toxicity to fish, with 48h LC50s in the range of 10 to 100 mg per litre. The group of dyes of very high toxicity to fish includes, for example, a formulation of malachite green.

The clinical symptoms of fish poisoning by different dyes are not specific. The patho-anatomic changes that indicate such poisoning may include a change in body colour due to the particular dyestuff, and the organs inside the fish body may also take on an intensive colour, e.g. as with malachite green.

3.2.10 Phytoplankton toxins

As described earlier in this publication increasing eutrophication of surface waters can cause a massive development of phytoplankton and higher aquatic plants. This bloom can cause the water pH to rise to levels above 10, and its collapse and subsequent decomposition together with other decaying organic matter can cause an oxygen deficit. Further, some algal species produce substances (toxins) that may affect not only fish but also domestic animals and man if the water is ingested. These species include, in particular, the blue green algae of the genera *Microcystis*, *Aphanizomenon* and *Anabaena*. An endotoxin, with the properties of cyclic polypeptides, has been isolated from the alga *Microcystis aeruginosa*.

In exposed fish, the action of these blue-green algal toxins is to increase thiaminase activity and reduce thiamine content in organs and tissues; this leads to a vitamin B₁ deficiency. The toxins are released into the water during the period of algal bloom particularly when the cells die and decompose. These toxins can enter the fish through the gills and body surface; some may also be ingested with food. The clinical symptoms of poisoning include damage to the central nervous system. Initially, there is increased activity and respiration, followed by uncoordinated movements; finally the fish lie flat on the bottom and die. The major patho-anatomic signs include haemorrhages on the skin and gills and in the internal organs.

Some phytoplankton species have been found to produce hydroxylamine as a by-product of their metabolism. The occurrence of this hydroxylamine in the heavily eutrophicated waters of some ponds is also accompanied by a high concentration of organic substances; these reduce the oxide reduction potential of the environment, thus allowing the hydroxylamine to accumulate. For this reason, the highest hydroxylamine concentrations are usually recorded in surface waters during the periods when a bloom of blue-green algae is decomposing, and under these conditions, the concentrations may reach toxic levels for a short time. Hydroxylamine is highly toxic to fish, its LC50 for acute exposure being less than 10 mg per litre (in sensitive fishes it may be as low as about 1 mg per litre). The toxic action of this substance includes severe methaemoglobinaemia and damage to the central nervous system. Although there are few cases where damage to fish has been attributable to the action of phytoplankton toxins, this possible source of pollution should not be underrated, especially in warm regions.

4. DIAGNOSING THE CAUSE OF FISH POISONING

The diagnosis of fish poisoning is a difficult and complicated task because there may be a delay in the discovery of the mortality, and the fish and water are then not sampled at the time when the pollution occurred. In such cases the patho-anatomic changes in the fish are obscured by the onset of post-mortem changes and the toxic conditions that caused the fish to be poisoned may have been carried away from the affected area with the water flow or, in the case of natural events, reverted to normal. Hence, it is necessary to use all the available information and all possible and relevant analytical methods to detect the cause of the harm to fish and, where appropriate, to aquatic invertebrates.

The analytical study should begin with an assessment of previous records of factors that might influence natural changes, and of recent discharges that may have been made, and then performing the necessary physico-chemical and hydrobiological analyses of the water. If necessary, the bottom sediments, the periphytes and then the fish themselves should be examined. Bioassays to measure whether the water has an acute toxicity is an important tool in the diagnosis of fish poisoning.

4.1 Examination *in situ*

If the fish are observed to be behaving strangely or are dying, the following important actions should be taken at the site.

- (a) Define the area within which the fish are seen to die or change their behaviour.
- (b) Catch some of the affected or newly dead fish and submit them to veterinary examination as soon as possible. Recognized procedures should be used for their storage and/or preservation.
- (c) Record the status of the zooplankton, phytoplankton and benthic communities.
- (d) Take water samples for hydrochemical analysis (some of the analyses and measurements must be carried out at the site e.g. O₂, temperature, pH, transparency, smell, colour etc), and for the bioassay for acute toxicity.
- (e) Draw a map of the affected area (and, if appropriate the surrounding areas) and record the site where water and sediment samples were taken. Fill in a form (an example is given below) for the in-situ examination.

If it is suspected that the fish might have died or changed their behaviour because of a discharge or use of a chemical in the vicinity of the affected water course or pond or lake, detailed information should be obtained of the time and method of the use and disposal, and of the identification and amount of the chemical applied.

The following checklist is an example of the information necessary to document a local investigation into the cause of abrupt changes in the behaviour or of mortality of fish.

1. Day, hour and place of the investigation
2. Persons involved in investigation
3. Name and address of the organization that suffered the loss (e.g. the owner of the fishery)
4. Name or other identification of the watercourse or reservoir where fish were killed
5. Species and age of the fish that occur in the affected watercourse or reservoir
6. The number, species and age of fish killed
7. Clinical signs and macroscopic changes in those fish with a changed behaviour

- pattern
8. Present state of health of the fish in the watercourse or reservoir being investigated
 9. Status of zooplankton killed yes no
 phytoplankton killed yes no
 benthos killed yes no
 aquatic plants killed yes no
 10. Possible sources of pollution that might be associated with mortality of the fish
 11. Preliminary estimate of the extent of the damage (length or area of watercourse or reservoir affected)
 12. Total weight of the dead of each species of fish
 13. Place, hour of sampling, description of samples and their purpose
 water
 sediments
 periphyton
 fish for examination:
 - newly killed
 - with clinical symptoms
 - with no signs of intoxication or disease
 14. Measurement of water quality *in situ* (including water temperature, pH, colour, transparency, smell, concentration of dissolved oxygen, and ammonia concentration)
 15. Opinion of the participants in the site investigation on the cause of the damage
 16. Signatures of local investigation participants

If the fish are thought to have been killed by the use of a chemical in the vicinity of a water course or reservoir (e.g. a pesticide), the following data should also be included in the report of the site investigation:

1. Day and hour when a crop was treated
2. Chemical used (trade name, name and content of active ingredient, application rate, concentration)
3. Method of application
4. Identification at the land and type of crop treated, the area of the crop treated, distance from watercourse or reservoir, location of drainage ditches
5. Name and address of the employer of the person who carried out the treatment
6. Prevailing weather when the field was treated (wind direction, wind speed, rain, cloudiness) and rainfall records for the period between the application and the fish deaths.

Map: A sketch map of the location, indicating the area where fish had died and the places where water samples were taken.

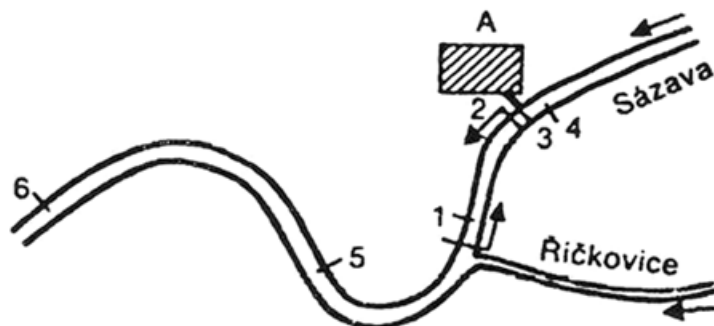

A - Fenolana plant

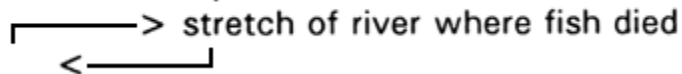

Water sampling sites

- 1 - place where the greatest kill was observed - 10.00 h September 20th
- 2 - 60 m downstream of the sewer outlet - 10.15 h
- 3 - at the sewer outlet - 10.30 h
- 4 - 40 m upstream of the sewer outlet - 10.45 h
- 5 - about 3 km downstream of the sewer outlet - 11.45 h
- 6 - about 6 km downstream of the sewer outlet - 12.30 h

4.2 Hydrochemical examination

The choice of the right sampling sites and the correct water sampling method is the main prerequisite for a successful diagnosis, so this must be given maximum attention. In flowing waters, water sampling sites should be distributed as follows:

- (a) at the place of the incident where the fish died, or are dying, or exhibit a strange behaviour
- (b) upstream of the above location:
 - 50 to 100 m downstream of a possible pollution source(s)
 - at the place where the pollution source joins a watercourse stocked with fish
 - 30 to 50 m upstream of the possible pollution source
- (c) downstream of the place of the incident: at sites where the first signs of an unusual behaviour of the fish are observed. Sampling sites downstream of the place of the incident have to be determined by calculation if there has been a delay in arrival at the site: the front of the polluted area can be calculated from the time of discharge of the possible pollutant and the flow rate of the watercourse.

4.2.1 Water samples

In reservoirs and fish ponds, the places where water should be sampled should be located on the basis of each specific situation; in some cases the samples may have to be taken from different depths within the water column. Special sampling equipment (e.g. the Hrbáček displacement bottle, Fig. 6) are used to take water samples from different depths and from just above the bottom.

The samples are poured into clean 1- to 2-litre bottles. It is not recommended that bottles are filled with water taken from near the bank or shore; it is usual to take the samples from 1–2 m away from the water's edge. Water samples from near to the bottom must be taken with care in order not to include mud and other sediment. To obtain the maximum value in terms of analytical accuracy and usefulness of the data, the time between sampling and analysis must be as short as possible. Ideally, the samples should be transported in thermally insulated containers. In the laboratory the samples should be stored in refrigerators and kept at 3–4°C. However, these procedures may not be adequate to ensure the stability of some water parameters. In such cases, the samples must be analyzed as soon as they are collected, or they may be stabilized with a small amount of preservative. Detailed data on the preservation and treatment of the samples are given in Table 3.

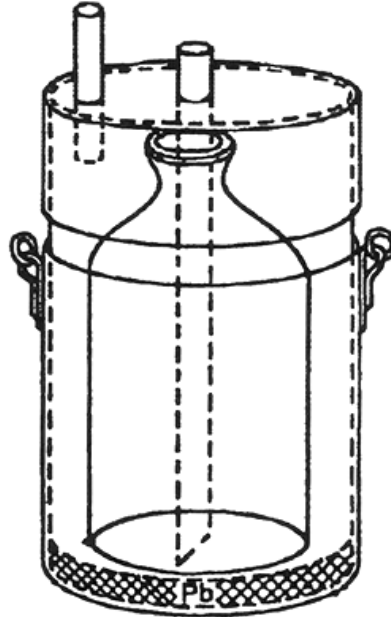

Fig. 6: Hrbáček's displacement-type bottle for water sampling to determine the concentration of dissolved oxygen (Hrbáček et al. 1974)

TABLE 3: Preservation and treatment of water samples

Water characteristics	Preservative (amount per 1 litre of sample)	Method of sample treatment
Temperature	-	Measure during sampling
Colour	-	1. Determine during sampling 2. Store at 4°C - determine within 24 h
Transparency	-	1. Determine during sampling (field determination) 2. Determine within 24 hours (laboratory determination)
Odour	-	Identify some smells during sampling (e.g. chlorophenol), others within 24 h at the maximum
pH	-	1. Determine during sampling 2. Take sample in oxygen bottle - see Fig. 20, determine within 24 h
Oxygen capacity	-	1. Determine during sampling 2. Take sample in oxygen bottle determine within 24 h
Dissolved oxygen (if DO probe is not used)	-	Take sample in oxygen bottle, fix after collecting winkler
Chemical oxygen demand COD _{Mn} , COD _{Cr}	a) 1 ml H ₂ SO ₄ b) store at 4°C	Determine as soon as possible after sampling, within 24 h at the maximum
Biochemical oxygen demand (BOD ₅)	-	Maintain at 4°C, process within 24 h
Ammonia	a) 1 ml H ₂ SO ₄ b) 3 ml CHCl ₃	1. Determine during sampling 2. Store at 4°C - determine within 24 h 3. Determine after preservation
Nitrates, nitrites	a) 1 ml H ₂ SO ₄	1. Determine on the day of sampling 2. Maintain at 4°C - determine within 24 h 3. Determine after preservation
Chlorine	-	Collect into brown bottle, determine immediately after sampling
Cyanides	solid NaOH up to pH 11 at least	Determine immediately, or at least within several hours after sampling
Copper, zinc	5 ml HNO ₃	Cannot be preserved if sample contains cyanides
Iron (total)	5 ml HNO ₃	Completely filled bottles: prevent contact with air
Phenols	NaOH added to obtain pH 11 (about 4 g per litre)	1. Determine within 24 h 2. Determine after preservation 3. No phenol preservation needed at phenol levels above 150 mg per litre
Tensides: anion active cation active nonionic	3 ml CHCl ₃	Collect to glass bottles, determine within 72 h
Petroleum and its products	The sample volume is 1 to 5 litres, depending on the pollution situation. Use glass bottles (never use polythene bottles). Avoid sampling the surface film of oil. Determine as soon after sampling as possible.	

The basic chemical analysis of the water includes the determination of the colour, odour, pH, acid capacity (alkalinity), concentration of dissolved oxygen, chemical oxygen demand (COD), biochemical oxygen demand (BOD₅), ammonia, nitrites, nitrates, phosphates and total phosphorus. The need to analyze for any other chemicals depends

on the outcome of the local investigation into possible sources of pollution; the aim is to obtain chemical data which, together with ecotoxicological data, will identify the causes of the mortality or damage of the fish. When assessing the results of the physico-chemical analysis of water samples in order to identify causes of mortality, the parameters should not be evaluated in isolation; possible interactions have to be taken into account. The toxicity of the different chemicals and products to fish and aquatic invertebrates is influenced by the natural quality characteristics of the aquatic environment.

Chemical examination of the water is carried out on site during the field investigation and in the laboratory. For field analyses, a portable chemical laboratory, such as Hach or the Combi kit, produced by the Central Laboratories of the Fish Culture and Hydrobiology Research institute at Vodňany, Czech Republic, can be used. The Combi kit can be used for the following determinations: Secchi disc water transparency, concentration of dissolved oxygen, pH, alkalinity, ammonia and phosphates.

Concentrations of metals in the water are measured by the atomic absorption spectrophotometry (AAS). The gas and liquid chromatography methods are used for the determination of organic compounds, e.g. the active ingredients of pesticides, surfactants, organic dyes, PCBs.

4.2.2 Sediment samples

Where required, benthic sediments may be sampled in addition to collecting samples of water. This is the case, for example, when there is suspicion of watercourse or reservoir pollution with petroleum products, metals, pesticides and other persistent substances which can accumulate in sediments.

There is no standardized method for sediment sampling; local conditions must always be taken into account. The main principle is to take the samples mainly from the top layer of the sediments, to take them at several sites within the locality investigated, and to thoroughly mix each sample before analysis. Benthic sediments are analyzed using modifications of the methods used for determination of pollutants in water and other (mainly biological) materials.

4.3 Hydrobiological examination

4.3.1 Aquatic communities

Hydrobiological examination of water is very important for a diagnosis of the poisoning of fish and lower aquatic organisms. This examination includes an evaluation of the qualitative and quantitative structure (at the individual, population and community levels) of the lower aquatic organisms in order to assess the extent to which they are damaged, and to record changes in behaviour of the fish, or the extent and duration of the mortality in their populations. Evidence that a specific group of poisons was responsible for the pollution can be obtained from the changes in the composition of the aquatic community after the incident. For example, crustaceans and insect larvae are very sensitive to insecticides, aquatic plants are sensitive to herbicides, algae to algicides etc. In cases of accidental pollution of watercourses and in reservoirs, effects on aquatic invertebrates are usually the first indicator of pollution of the aquatic environment, and the effects on fish are seen later. This is especially characteristic of the pollution of watercourses and reservoirs with pesticides and some metals. However, surface active compounds (e.g. surfactants) have a similar toxicity to fish and to aquatic invertebrates. On the other hand, fish are the main indicators of pollution where organic substances are accidentally discharged to watercourses or to reservoirs.

4.3.2 Examination of periphyton

Periphyton form a mat consisting of an association of aquatic organisms (bacteria, fungi, algae, protozoans, bryozoans, rotifers and others) growing on, or attached to, surfaces such as the stems of higher aquatic vegetation, stones, structures built in water, and submerged logs. In surface waters, periphyton is an important source of food for many aquatic animals, including fish. It makes a significant contribution to the self-purification processes in rivers and lakes, and its quality and quantity provides an indication of the average quality of water at a specific site; short-term and minor changes in water quality usually exert an influence on the community structure of organisms which make up the periphytic mat. This is of great importance in water analyses. After an accidental discharge into a watercourse, mainly characterized as a volume of toxic water killing the free-living organisms and carrying them downstream, the damaged periphyton may provide information about the length of watercourse affected, and those upstream on the quality of water during the preceding period. Periphyton analyses are an important part of the general examination of water quality, particularly in places with flowing water where the analyses of single samples taken from single sampling sites fail to provide a true indication of the water quality over a period of time.

Periphyton samples are usually obtained by removing them from the different submerged surfaces with a pair of long tweezers. A scraper attached to a long handle will be of help in water of greater depths. The periphyton attached to underwater structures of concrete or other materials can be easily scraped by means of a stiff brush (such as used for washing laboratory glassware) attached to a long pole; the material attached to the bristles of the brush is then transferred into the sampling phial, using a pair of tweezers. In the laboratory, the periphyton samples are subjected to analysis by a microscope; the organisms present in the samples are identified and their abundance is recorded using a qualitative scale.

4.3.3 Biological assay for water toxicity testing

An investigation in the cause and tracing the source of a pollution incident in a water course or reservoir can include, besides the hydrochemical and hydrobiological analysis, a bioassay for water toxicity. The water used for the bioassay is taken from the water sample (free of preservatives) sent to the laboratory for physico-chemical analysis. The aquatic organisms used for the assay include aquarium fish, especially *Poecilia reticulata*, and aquatic invertebrates, especially the water flea (the genus *Daphnia*) which is one of the most sensitive of aquatic organisms to the majority of pollutants. Although *Poecilia reticulata* is not an extremely sensitive fish, its advantage is that like the majority of aquarium fish it is easily available all the year round.

The following procedures for the bioassay of water toxicity are generally used. Ten water fleas (*Daphnia*) or two or three aquarium fish (*Poecilia reticulata*) are put in 100–200 ml of the water sample. If a sufficient water sample volume is available, the assay is carried out simultaneously on both organisms. At the same time, the same number of organisms are put in uncontaminated water to act as controls. The best test vessels are, in our experience, crystallizing dishes where the water depth is shallow, allowing sufficient oxygen to diffuse from the air into the water. The behaviour and state of the organisms are monitored during the period of the bioassay, which may be from 24 to 48 hours.

If the result of the assay is negative (the behaviour patterns of the fish or water flea do not differ from the controls), it may be assumed with some confidence that the water sample tested does not contain toxic substances at acutely harmful or lethal

concentrations. If the test organisms show changes in their behaviour or die, physico-chemical and/or other analytical methods should be carried out as soon as possible to find the cause of the poisoning.

Although a bioassay for water toxicity testing cannot provide a positive identification of the causative agents of the mortality of fish and other aquatic organisms, it can provide useful information for the diagnostic process, including locating the source of the pollution. Other aquatic organisms, e.g. rainbow trout, common carp or cyclops (an aquatic microcrustacean), may also be used for the bioassays, but these may not be available all the year round or, if they are, not at a convenient size. Rainbow trout and common carp have the additional disadvantage of requiring a large volume of sample for the bioassay and the water has to be aerated. It is a common principle for all water toxicity bioassays that the methodology can be varied: in specific cases they may reflect the actual field conditions at the time of the investigation, within the restraints of the facilities available at the laboratory.

4.3.4 Examination of the fish

The number of the fish that have to be examined and sent for diagnostic examination is not always the same. If there is any suspicion that fish might have been poisoned or suffocated by water pollution, samples of 3 to 5 fish are taken from each species that is common amongst those that are the dead or dying. If such a situation occurs in a reservoir (pond) with a single-species stock, the number of fish sampled should be between 5 and 20, depending on their weight, age and other particular circumstances.

The success of the examination depends on the state of the fish. It is useless to send fish that have started to decompose or are decayed. Ideally, the sampled fish should be showing clinical symptoms of damage and be delivered alive. If this is impossible, it is absolutely essential that the fish be fresh and intact when they reach the examining laboratory. They should never be sent in the water in which they have died. The fish sent for general examination should be free of preservatives (formalin, alcohol etc.) because these make the diagnosis impossible. In those cases when the fish are only sent for chemico-toxicological examination (i.e. for the tissue concentration of metals, residues of pesticides, and other pollutants), it is recommended that the samples should be frozen.

Fish that are sampled at the point of death, or those with clinical symptoms of damage, are subjected to a detailed health examination in order to eliminate infective or invasive diseases as a cause of the harm. If such diseases are eliminated, it is then necessary to identify those environmental factors which changed abruptly and caused the death of the fish or a change in their behaviour. The clinical symptoms given in the report of the local investigation are evaluated as the first stage of the examination; this is followed by the patho-anatomic dissection, and where necessary the organs and tissues of the fish are subjected to chemico-toxicological analysis. Further examinations can be performed if the information obtained shows that these are necessary.

Chemico-toxicological examination of the organs and tissues is one of the most definitive, and also the most difficult, of the methods used in the diagnosis of poisoning. Where there is a possibility that the poisoning has been caused by metals, or for the monitoring of metals in fish for human consumption, the chemico-toxicological examination is a justifiable requirement. Such examinations may also be carried out when phenol and pesticide pollution may be involved and, if certain conditions are met, chemico-toxicological analysis may help in the diagnosis of ammonia poisoning in fish.

On the other hand, there are some substances (e.g. chlorine, hydrogen sulphide) for which appropriate analytical methods are not available.

The concentration of metals in fish organs and tissues is determined by atomic absorption spectrophotometry (AAS). An increase in the concentration of metals is most frequently recorded in the parenchymatous organs and in the gills of the fish. For example, acute copper poisoning can be diagnosed on the basis of chemical analysis of the gills, if the metal concentration has been significantly (several-fold) increased. The copper content in gills of fish in uncontaminated water is up to 10 mg per kg dry weight.

Fish poisoning by organo-phosphorus pesticides can be diagnosed either by direct measurement of these substances or their metabolites in the organs and tissues, or by indirect determination, based on the inhibition of acetylcholine hydrolase mainly in the brain of the fish. This method is applicable also to the diagnosis of fish poisoning by carbamate pesticides. Diagnosis of fish poisoning by other pesticides and also by other organic compounds may be based on the determination of these substances in the organs and tissues of the fish using gas chromatography.

It must be stressed at this point that most of the ecotoxicological information for chemicals relate to harmful concentrations in the water; there is very little information on harmful tissue concentrations. Therefore, the identification of a chemical in fish tissue does not prove that it was responsible for the damage, unless it can be shown that the concentration present has been associated with harm in carefully conducted laboratory experiments.

One of the chemico-toxicological methods that has been used in the diagnosis of poisoning is the detection of phenols in fish. The chemicals are determined in the flesh and skin of the fish by a photometric method using 4-amino-antipyrine after reflux distillation of the tissue sample.

Ammonia poisoning of fish can be diagnosed, if certain conditions are met (fish blood and brain sampled during toxic exposure or immediately after death, and analyses made within 48 hours at the latest on deep-frozen samples), by determining the ammonia nitrogen levels in the blood serum and brain homogenate. These levels can be readily determined using the Blood Ammonia Test kit, made by Hyland. However, the ammonia nitrogen level in the serum and brain of fish varies with their metabolic rate and will increase in response to various adverse factors, especially O₂ deficiency. Because of this variability it is impossible to diagnose ammonia poisoning of fish merely by determining the ammonia N level in these specific tissues; the definitive diagnosis must be based on a thorough examination of the water quality and a detailed examination of the state of health of the fish.

The presence of petroleum and its products in fish can be easily detected by characteristic changes in odour and taint; the "petroleum smell" can be detected at concentrations as low as 0.01 mg per litre of water. Contamination of water by phenols and chlorophenols can be detected in the same way at or above concentrations of 0.1 mg per litre and 0.02 mg per litre respectively. This sensory method of detection needs no sophisticated laboratory equipment, and its sensitivity compares favourably with that of chemico-toxicological examination.

5. CONTROL OF WATER QUALITY

5.1 General principles for preventing fish poisoning

Everyone who manufactures, handles, or uses substances that can pollute the environment should regularly check their equipment and take the appropriate measures to prevent accidents; this is a moral obligation, which is also contained in the legislation of many countries. A strict discipline and a proper responsibility exercised by all those who are involved in every stage from manufacture to disposal provides the most effective, the most readily available and the cheapest means of pollution prevention.

The main method for preventing the chronic pollution of surface water is the installation of treatment plants, as are used for domestic sewage and for industrial effluents. In principle, all waste waters must be treated before they are discharged into the aquatic environment. These treatment processes may be simple; for example, the so-called biological oxidation ponds are used to intercept and biodegrade the organic wastes derived from agricultural production (livestock fattening and rearing facilities, including those for waterfowl) and from the food industries (slaughterhouses, poultry processing plants, dairy products, etc.). To a lesser extent these oxidation ponds may be used to intercept and degrade the sewage from residential areas, so long as such waste waters are not polluted with petroleum products, PCB, pesticides and other dangerous chemicals that are resistant to degradation.

However, oxidation ponds need to be extensive because of the large surface area required to allow sufficient oxygen to diffuse into the water. The amount of land required can be reduced by increasing the water surface area either by the use of stones or other media in trickling filters or by artificial aeration (the activated sludge process), both widely used in sewage treatment works. Substances that are not degraded by biological oxidation should be removed from waste waters by specific processes.

The removal of soluble harmful substances from waste waters usually results in the production of a precipitate or sludge. The disposal of these solids can cause problems if they are spread or contained on land and harmful substances (including by-products) can leach from them into surface waters. The environmental fate of such waste products needs to be carefully examined and appropriate steps taken to prevent aquatic pollution from their disposal.

At industrial sites, especially at those factories where there is a danger of leakage of oils and refined products or other very toxic substances into drains that discharge directly to surface waters, it may be necessary to build special leak-proof pits or containment walls to protect the nearby aquatic environment from contamination.

Apart from these direct discharges to water, considerable attention should be paid to some of the technological processes used in agriculture, in particular the spray application of chemicals, including fertilizers and pesticides, onto fields. Any direct drift of the chemicals to water areas during their application should be avoided and in particular precautions should be taken to prevent the subsequent leaching of the chemicals by rainfall into rivers and ponds. Such precautions are incorporated in the regulations set to control such applications (no chemical spraying in wet or windy weather, or 24 hours before rain is expected etc.). They are also reflected in some principles of land management; the use of grassy strips around water reservoirs, the use of appropriate crops (e.g. those not needing excessive pesticide application) and the proper tillage of sprayed fields. However, the improper disposal of surplus or unused pesticides, or the

careless disposal of containers, is probably responsible for more pollution incidents than the proper use of pesticides on land.

It is required by current regulations that any new chemical must be subjected to a programme of toxicological testing and evaluation before it can be placed on the market. In particular, its potential for biological degradability, acute and chronic toxicity and/or teratogenicity and mutagenicity should be established. For pesticides, priority should be given to chemicals with a high target selectivity, a low active concentration, a low toxicity to non-target species and a rapid degradability. As stated earlier, the natural environment should not be allowed to become contaminated with toxic substances of low degradability.

The toxicity of substances, formulations and effluents to fish depends, first of all, on their chemical properties (e.g. their composition, water solubility, and pH), then on the sensitivity of the fish exposed to these substances. Within species, salmonids are generally the most sensitive, and cyprinids tend to be somewhat more resistant; within life stages, older fish tend to be more resistant than younger fish. Also important is the general state of health of the fish including the state of feeding of early fry and, finally the influence on toxicity of the water quality characteristics of the aquatic medium (temperature, pH, dissolved oxygen concentration, hardness, etc.).

5.2 Evaluation of the preparations and effluents

5.2.1 General principles

For fisheries management and fish culture, the most important property of any new product or chemical is its toxicity to aquatic organisms. Toxicity tests are designed to provide information on the potential harmfulness of the chemical at three levels of biological organisation:

- (a) cells and tissues
- (b) organisms (individuals)
- (c) biocoenoses (communities).

The cell- and tissue-level tests are often used to provide an explanation for the findings obtained from experiments conducted at the organism level. Their advantage is their small scale and good reproducibility but unfortunately the results obtained *in vivo* often differ considerably from those found *in vitro*. At the other end of the scale, tests on biocoenoses have the advantage that the toxic actions are studied in either the natural environment or with a model which can simulate reality with reasonable accuracy. However, such tests have their drawbacks; the changes in community composition may not always be a consequence of direct toxic action on a given species but may be due to a disturbance in the food chain or other natural factors. The reproducibility of such tests is often very limited because their wide natural variability makes it difficult to obtain exactly the same conditions as those of preceding tests.

For these reasons, most of the studies are performed at the organism level, especially for acute toxicity tests. Though there are still problems of reproducibility, and errors can be made when extrapolating from these results to actual natural conditions, such tests represent a practical compromise and are generally acceptable to the fish culturist, industrialist and economist, and to a lesser extent the conservationist.

A distinction is drawn between acute toxicity and chronic toxicity; hence, substances, preparations and/or waste waters (effluents) which have been subjected to

acute toxicity tests and shown to have harmful properties are then tested for chronic toxicity. Almost all these tests are carried out at the organism level.

5.2.2 Acute toxicity tests

Determination of the acute toxicity of chemical substances, formulations and effluents to aquatic organisms is one of the main duties of those responsible for their production. The majority of the acute toxicity tests are performed on fish and selected aquatic invertebrates. A variety of methods of toxicity test methods have been standardized in different countries. Some of these procedures are recognized internationally, notably the standard methods published by the International Standards Organization (ISO), and the guidelines given by the OECD. For determining the acute toxicity of substances to aquatic organisms, the following ISO methods are now widely used:

- ISO 6341 Water quality - Determination of the inhibition of the mobility of *Daphnia magna* Straus (*Cladocera, Crustacea*) issued in 1982
- ISO 7346/1 Water quality - Determination of the acute lethal toxicity of substances to a freshwater fish [*Brachydanio rerio* Hamilton-Buchanan (*Teleostei, Cyprinidae*) - Part 1: Static method of 1984
- ISO 7346/3 Water quality - Determination of the acute lethal toxicity of substances to a freshwater fish [*Brachydanio rerio* Hamilton-Buchanan (*Teleostei, Cyprinidae*)] - Part 2: Semi-static method of 1984
- ISO 7346/3 Water quality - Determination of the acute lethal toxicity of substances to a freshwater fish [*Brachydanio rerio* Hamilton-Buchanan (*Teleostei, Cyprinidae*)] - Part 3: Flow-through method of 1984
- ISO 5664 - Inhibition of algal growth.

These standard acute toxicity tests use the highly sensitive water flea *Daphnia magna* and the aquarium fish *Brachydanio rerio*; the procedures also allow for the use of some other fish species, e.g. *Poecilia reticulata*, *Pimephales promelas*, and *Oryzias latipes*. The basic data obtained is the LC50 for periods of 24, 48, 72 and 96 hours; for *Daphnia* the usual maximum exposure period is 48 hours. In order to complete the trophic levels of primary producers, herbivores and carnivores, acute toxicity tests are carried out with algae.

Apart from these standard methods of toxicity testing, laboratories worldwide have developed many modifications of these toxicological methods. In doing so, the laboratories have taken into account the prevailing natural and economic conditions in their country and in each particular region. Some countries have standardized the methods of determining the tests of acute toxicity of waste waters to freshwater fish (e.g. the USA, UK), others have introduced special tests for the determination of the toxicity of pesticides to fish (e.g. Japan, the USA). The national methods differ in the test organisms used, in the time of exposure, and in the type and temperature of the water used for dilution, but in the majority of cases the main output is the LC50 value as the most accurate of the measurements that can be made.

The standard methods used in the former Czechoslovakia, ON 46 6807 Acute Toxicity Test on Fish and Other Aquatic Organisms, have been derived from the above-mentioned ISO standards and OECD guidelines. In these methods (which include a "range-finding" test to precede the definitive test), the basic test organisms are *Daphnia magna* and *Poecilia reticulata*, and the auxiliary species include common carp, rainbow trout, *Brachydanio rerio*, *Rasbora heteromorpha*, Cyclopidae, Tubificidae; also, the larvae of the amphibians *Xenopus laevis* and *Rana temporaria* are used in special tests.

The selection of these aquatic organisms for acute toxicity tests should be matched to the purpose for which the tested substances are being evaluated. For example, when evaluating a substance or preparation for use in fish culture or for direct application to the aquatic environment, toxicity tests will have to be performed on a wide range of representative aquatic fauna. On the other hand, for classification of substances into categories, e.g. newly developed products for general use but on a limited scale, the basic compulsory tests on *Daphnia magna* and *Poecilia reticulata* may be sufficient. However, tests on other species, e.g. *Rasbora heteromorpha* may be required if the chemicals are to be exported.

In line with the internationally agreed methods, the Czechoslovak standard methods in ON 46 6807 recommend the use of artificially prepared dilution water. Further, they include the use of a reference substance, i.e. a control preparation, within the test. Deviations in the LC50s obtained for the reference substance will reflect the variability in the conditions under which the tests are performed and in the condition of the organisms tested. Large deviations may indicate that the test laboratory has not achieved the necessary accuracy and precision required for carrying out a standard method. Potassium dichromate ($K_2Cr_2O_7$) is the most frequently used reference substance.

From the lowest value obtained for the 48h LC50, determined on the basis of ON 46 6807, a test substance or product is classified (in Czech Republic) into one of the following toxicity categories:

- 0 - substances of almost no toxicity: substances in which the 48h LC50 is higher than 10 000 mg per litre,
- 1 - substances of very low toxicity: substances in which the 48h LC50 is between 1 000 and 10 000 mg per litre.
- 2 - substances of low toxicity: substances in which the 48h LC50 is between 100 and 1 000 mg per litre,
- 3 - substances of medium toxicity: substances in which the 48h LC50 is between 10 and 100 mg per litre,
- 4 - substances of high toxicity: substances in which the 48h LC50 is between 1 and 10 mg per litre,
- 5 - substances of very high toxicity: substances in which the 48h LC50 is between 0.1 to 1 mg per litre,
- 6 - substances of extreme toxicity: substances in which the 48h LC50 is less than 0.1 mg per litre.

The test substance or preparation is placed in the appropriate toxicity category on the basis of the 48h LC50 obtained for the most sensitive organism tested.

The acute toxicity test can also yield further data which should be reported: - LC5 (concentration that kills 5% of the individuals within the given period of time), formerly also referred to as the minimum lethal concentration;

- LT50 (the time within which half of the individuals are killed at the given concentration of the substance), also referred to as the mean or median survival time;
- Relation between the LT50 and the concentrations of the substance tested (the toxicity curve);
- Description of changes in the behaviour of fish or other organisms during the test, obvious changes found in the fish from the patho-anatomic dissection, and visible effects on the aquatic invertebrates. *Poecilia reticulata*, *Brachydanio rerio* and *Rasbora heteromorpha* are examined for their ability to consume normal quantities of food at the end of the test.

5.2.3 Chronic toxicity tests

The maximum concentration of a substance in water which still allows the normal growth and reproduction of fish, (MAC, maximum admissible concentration) forms the basis for assessing the quality of the water supplied to fish culture facilities, for investigating the causes of fish damage or mortality, or for giving permits for the discharge of effluents (which are likely to contain several significant contaminants) to surface waters. The MACs are usually derived from the results of chronic toxicity tests.

A standard procedure for the use of chronic test data in the assessment of limiting toxic concentrations of substances, products and effluents has been proposed by Lesnikov (1976). Lesnikov defines the MAC as the maximum concentration of a substance or its metabolites in waters at which a continuous exposure has no adverse effect on:

- (a) the hydrochemical regime of water courses, lakes and ponds and on the microorganisms,
- (b) primary production in the above-mentioned water bodies,
- (c) planktonic food organisms,
- (d) the fish (including the eggs and fry during larval development as well as fish in higher age categories) and also the marketable value of the fish (the hygienic requirements).

The recommended procedure for determining the MAC is first to perform acute toxicity tests, then test for the rate of detoxification (e.g. by degradation) of the substances and their metabolites into less toxic products, and finally, longer-term observations based on the results of acute toxicity tests and detoxification tests. The MAC should then be derived on the basis of the parameter (e.g. the response of an organism) which is adversely affected by the lowest concentration of the substance or its metabolite. The three major hazardous properties of a chemical or product are its potential for toxicity, persistence and bioaccumulation. High values for any one of these alone may not cause the substance to be hazardous in practice; for example, a very high toxicity combined with a half-life of a few minutes will not present a high environmental risk. It is clear, however, that substances of high stability (i.e. a very slow decomposition into non-toxic compounds even at summer temperatures over six months), with a high bioaccumulation capacity (>1000 times) and with a MAC below 0.0001 mg per litre will be regarded as particularly dangerous.

Salmonids, usually up to one-year-old rainbow trout (about 12 cm length), are most frequently used for the chronic toxicity tests. The main parameters examined at the end of such tests are the physical condition or condition factor (ratio between length and weight) of the fish, the individual and total weight gain of the fish, the change in the

odour and taste assessment of the flesh, and the extent to which toxic substances are accumulated in the fish body or specific organs. The supplementary parameters include the behaviour of the fish during the test, the patho-anatomical and histo-pathological picture, and the physiological, biochemical and haematological changes in the fish when the test is terminated. Together with the basic parameters studied, the histological examination of the organs and tissues at the end of long-term tests is one of the most important items for the evaluation of the results, because its findings usually represent the most sensitive response, and therefore form the basis for setting the MAC. Also, specific effects found can assist in the diagnosis of the cause of harm to fish in natural populations.

These principles are incorporated in the manual of methods by Svobodová and Vykusová (1991). This manual recommends that the duration of the chronic toxicity test be 90–100 days and that common carp and rainbow trout are used as experimental fish. A reasonably stable concentration of the test substance is maintained by transferring the fish into a fresh solution of the toxic substance every day, usually after they have been fed. The concentration at which there were no significant effects on the experimental fish, when compared with the control group, is taken as the maximum admissible concentration (MAC).

Among the aquatic invertebrates, chronic toxicity tests are mainly conducted with the water flea *Daphnia magna*. All the individuals of this species used in the test must be of the same age (3–7 days), which can be achieved by synchronized culture. The main test parameters are survival of the adults, release of the young from the brood sac, viability of the juvenile stages, and change in the biomass. Subsidiary parameters and criteria recorded during the toxicity tests are behaviour before and during mortality, condition of the gonads, contents of the brood sac, feeding (as shown by the content and colour of the intestine), body colour, and abundance and colour of fat droplets. A detailed description of this method is given in the OECD guidelines.

Water fleas can also be used for a reproduction toxicity test, based on the capacity of several successive generations to reproduce in a range of concentrations of the test substance. The parameters examined include the release of the young, the number of the young, their survival, and potential for parthenogenetic reproduction.

5.2.4 Other toxicity tests

Considerable efforts have been made in recent years to replace the lengthy and therefore costly chronic toxicity tests by other tests, which would be as sensitive but considerably shorter. The use of cell cultures is one of the promising methods. These tests are based on the observation of the direct toxic action of chemicals on primary cell cultures from different fish tissues or on stable cell lines (e.g. FMH, PG, RTG-2 etc). These tests are still being developed; at present, their main value would seem to be for screening tests, rather than for the identification of long-term effects.

The use of embryo-larval toxicity tests is also being examined (the technique developed by Birge et al., 1977, is regarded as an ISO method). Exposure of the embryo to the toxic substance is continued until the stage when the yolk sac is completely absorbed. Unfortunately, the initial results of experiments conducted in our laboratories do not confirm the claims for a high sensitivity of this technique; toxic concentrations are not much lower than those obtained with the acute toxicity test. To obtain a greater sensitivity, the duration was extended to include a period of starvation, in which the mortality rate of the experimental fish is compared to that of the control fish. This

provided a slight improvement in sensitivity but even so the technique cannot completely replace the traditional chronic toxicity test.

It is clear, however, that no single chronic test technique will be appropriate for all types of toxic substances. Embryo-larval tests may be sufficient for those substances that can be readily detoxified by the fish (for which the MAC may be 1½ orders of magnitude lower than the 96 hour LC50), but they will be inappropriate for substances that are persistent and are highly bioaccumulated. For these substances, tests of long duration are required, perhaps with the feeding of contaminated food, and with fish of a reasonable size so that the accumulation and effects in different tissues and organs can be studied.

Another method which is becoming increasingly used particularly in marine toxicity tests is the bacterial bioluminescence inhibition technique (the Microtox test; ISO Standard N110/1988, a draft being prepared in France). Of course, this technique also has to be adapted to local conditions.

5.3 Persistence of substances in aquatic environment

In addition to toxicity, another important measure of the potential hazard of substances and products is their degradability in the aquatic environment. Such degradation may be by physical, chemical or biological processes; only biological degradation is considered here. Biological degradation involves a sequence of processes by which organic substances are broken down, metabolized or assimilated by micro-organisms. This may be measured by analyzing the processes involved in biodegradation (oxygen consumption, CO₂ production (i.e. non-specific method similar to the 5 day BOD test), or by measuring directly the rate of loss of the test substances from the aquatic medium over a period of time (a specific method).

Czech and Slovak ichthyotoxicologists, conservationists and water management experts generally use the technique proposed by Pitter (1974) as a standard test to measure the biological degradability of organic substances. This is a single-step kinetic test performed in an open system using dilutions of test substance with a mixed culture of bacteria. The decrease of the amount of the test substance is measured in terms of the reduction of the chemical oxygen demand (COD), of the total organic carbon (TOC), or by other more specific reactions. The results are compared with a blank test and with the degradability of a standard substance. Environmental importance is attached not only to the extent to which the substance is broken down but also to the rate at which it is degraded. For practical reasons it is recommended that biological degradability should be expressed as the percentage of removal of COD or TOC during the course of the incubation period.

When the results of biological degradability tests are used to predict what will occur in natural conditions, it should be noted that the tests were originally developed to simulate the conditions existing in a sewage treatment plant. A number of other factors such as temperature, bacteria, pH, dissolved oxygen concentration in water, can influence the rate of degradation of the test substance under natural conditions away from the sewage treated plants. Nevertheless, it is generally true that a substance that is readily biodegradable in a non-adapted activated sludge from a sewage treatment works is also very likely to degrade rapidly under natural conditions; as stated earlier, a sewage treatment plant concentrates the natural biodegradation processes into a small area.

The techniques for measuring the residues of the various pollutants and their metabolites in the various compartments of the aquatic environment are not easy to

perform except in highly specialized laboratories; for this reason, attention has been focused on the highly toxic substances and those which are not readily degradable (i.e. persistent). The residues can be measured directly by chemical analysis (e.g. for metals, DDT and its metabolites, HCH, PCB, triazines and others) and to a much lesser extent by bioassays (e.g. toxicity tests with *Daphnia magna* can be used to measure residues of organo-phosphate pesticides).

5.4 Legislation

Special legislation is now being developed in those countries where efforts are being made to maintain and improve the state of the aquatic environment. In addition, international conventions are being prepared and nationally adopted to promote the conservation of aquatic resources and the natural environment as a whole, especially for international rivers and marine areas.

The legislation of every country should include measures designed to prevent damage being caused to the aquatic environment by the action of various chemicals, products, waste waters and solid wastes. There are two types of legislation which can be used. The simplest is that based on liability; the person who causes the damage has to pay compensation to the person(s) affected by the damage, together with an extra financial penalty or even imprisonment to act as a deterrent. This legislation requires that the cause of the damage should be established, and much of the information in this document is given to show how this can be done in the case of pollution damage to fish. This is seldom an easy task as there may be several possible explanations for the cause of the damage. Nevertheless, the combination of careful research and the collection and analysis of case histories will provide a steady improvement in the ability to provide an accurate diagnosis.

The second type of legislation is that based on regulations. In the context of aquatic pollution, this includes codes of practice for the handling and disposal of chemicals, and the setting of MACs for specific chemicals in the water. These regulations require a comprehensive system of monitoring to ensure that they are properly enforced, and this continuing effort can be costly. However, the presumption is that the aquatic environment will have been damaged if the MAC is exceeded; therefore, the MAC must be accurately set and information given in this document shows how this can be done. The advantage of regulations is that they are preventative; the disadvantage is that they are costly to enforce, and are likely not to be enforced if the MACs are shown or thought to be too stringent.

In practice, most countries have a mixture of both types of legislation, the balance being determined by national, political and economic factors. However, whatever the type of legislation in force, it is essential that the duties of the producers and users of substances as well as those of the producers of wastes must be clearly defined. The penalties for violation or circumventing the legislation must be a sufficient deterrent, strict and regular inspections must be carried out, and there should be a strong emphasis on personal responsibilities.

The ultimate goal is clear: to reduce the number of pollution incidents in watercourses, to eliminate the sources of pollution, and to minimize the consequences of accidental discharges on aquatic life.

6. POLLUTION AND FISH DISEASES

The interrelationships between the host organisms, their pathogens and environmental factors are shown in Fig. 7. In an unpolluted environment with only the normal fluctuations in ambient conditions, there will be a natural balance between H, P and E, leading to sporadic outbreaks of disease. However, a reduction in the quality of E will lead to a marked increase in the frequency and severity of D, mainly by reducing the resistance of the host organisms to diseases. Also, an increase in the population density of H will increase the risk of disease outbreaks, as shown later in Table 4, as will an increase in the virulence of P. This chapter describes some of the effects of reduced water quality on the susceptibility of fish to disease.

It is possible that adverse environmental conditions may decrease the ability of organisms to maintain an effective immunological response system, so that an increased susceptibility to different diseases might be expected to occur. This certainly occurs in aquatic organisms, particularly fish, where acute and/or chronic pollution of surface waters can cause a reduction in the level of unspecific immunity to disease. For example, a significant decrease in the concentration of total proteins, globulins and lysozymes in the blood plasma of carp can occur after a long-term exposure to sublethal zinc concentrations. A decrease in the number of leucocytes and significant changes in their differential count are typical effects caused by a number of pollutants (e.g. phenols, metals, pesticides etc.); a characteristic decrease in the percentage of lymphocytes and an associated increase in granulocytes can occur. Such a decrease in the number of small lymphocytes which are active in the increase and transfer of globulins, is followed by a decrease in antibody production and thus a decrease in resistance to disease.

Any marked change in surface water quality is reflected both directly (as has been already mentioned) and indirectly in the structure of the fish population. Indirect effects can occur from damage to the food web which consists of lower organisms in the aquatic environment. There is a wide range in the susceptibility of individual species of aquatic organisms to different pollutants. In most cases, the lower aquatic organisms (i.e. components of the zooplankton and zoobenthos) contain the more susceptible species. Thus, at low concentrations of pollutants (e.g. metals, pesticides, surfactants etc.), damage and mortality of sensitive food organisms can occur. In consequence, although fish are not affected primarily, they suffer from secondary effects; the reduction and/or complete absence of natural food leads to a poorer condition of the fish and this may be accompanied by a decrease of antibody production. In this way, the disease resistance of fish may be decreased.

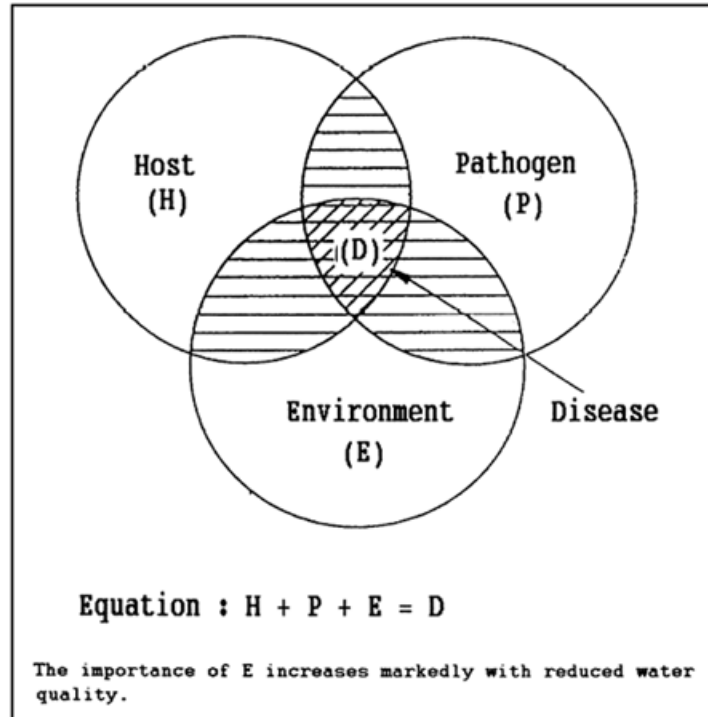

Fig. 7: Interactions between host, pathogen and environment, and the outbreak of diseases (after Wood, 1974; Bohl, 1989)

However, it must be stressed that not every outbreak of fish disease is due to pollution; other factors, such as overcrowding or the rapid increase in the number or virulence of disease organisms may be the primary cause. Nevertheless, the severity of the outbreak may be increased if accompanied by a reduction in water quality. The following fish diseases have been shown to have a close connection with reduced water quality.

6.1 Viral diseases

The presence or introduction of specific viral agents into ponds, reservoirs and streams is necessary to cause outbreaks of infectious pancreatic necrosis in salmonids, viral haemorrhagic septicaemia in rainbow trout, spring viraemia of carp, infectious swim-bladder inflammation, ulcerative dermal necrosis in salmonids, pox and other viral diseases. Where water quality is reduced, a more complicated course of the disease together with a higher mortality of fish are usually found. In particular, a reduced water quality is an important stress factor in viral haemorrhagic septicaemia. A low dissolved oxygen content and extreme changes in the pH of the water, together with an increased accumulation of metabolites, are other important factors associated with outbreaks of infectious haemopoietic necrosis in salmonids.

Table 4: Environmental factors which are harmful to warm and coldwater fish and increase their susceptibility to certain diseases (from Wedemeyer and McLeay, 1981)

Disease	Environmental stress factors predisposing to disease
Furunculosis (<i>Aeromonas salmonicida</i>)	Low oxygen ($\approx 4 \text{ mg l}^{-1}$); crowding; handling in the presence of <i>A. salmonicida</i> ; handling for up to a month prior to an expected epizootic
Bacterial gill disease (<i>Myxobacteria spp.</i>)	Crowding; unfavourable environmental conditions such as chronic low oxygen (4 mg l^{-1}); elevated ammonia (0.02 mg l^{-1} unionized); particulate matter in water
Columnaris (<i>Flexibacter columnaris</i>)	Crowding or handling during warm (15°C) water periods if carrier fish are present in the water supply; temperature increase to about 30°C , if the pathogen is present, even if not crowded or handled
Kidney disease (<i>Renibacterium salmoninarum</i>)	Water hardness less than about 100 mg l^{-1} (as CaCO_3); diets containing corn gluten or of less than about 30% moisture
Hemorrhagic septicemia (<i>Aeromonas</i> and <i>Pseudomonas</i>)	Pre-existing protozoan infestations such as <i>Costia</i> , <i>Trichodina</i> ; inadequate cleaning leading to increased bacterial load in water; particulate matter in water; handling; low oxygen; chronic sublethal exposure to heavy metals, pesticides or polychlorinated biphenyls (PCBs); for carp, handling after overwintering at low temperatures
Vibriosis (<i>Vibrio anguillarum</i>)	Handling; dissolved oxygen lower than about 6 mg l^{-1} , especially at water temperatures of $10\text{--}15^{\circ}\text{C}$; brackish water, of 10–15 per mille salinity
Parasite infestations (<i>Costia</i> , <i>Trichodina</i> , <i>Hexamita</i>)	Overcrowding of fry and fingerlings; low oxygen excessive size variation among fish in ponds
Spring viremia of carp and tail rot	Handling after overwintering at low temperatures. Crowding; improper temperatures; nutritional imbalances; chronic sublethal exposure to PCBs; or to suspended solids at $200\text{--}300 \text{ mg l}^{-1}$
Coagulated yolk of eggs	Rough handling; malachite green containing and fry more than 0.08% zinc, gas supersaturation of 103% or more; mineral deficiency in incubation water
"Hauling loss" (delayed mortality)	Hauling, stocking, handling in soft water (less than 100 mg l^{-1} total hardness); mineral additions not used; CO_2 above 20 mg l^{-1}
Blue sac disease of eggs	Crowding; accumulation of nitrogenous metabolic wastes due to inadequate flow patterns

6.2 Bacterial diseases

As with viral diseases, the presence of specific bacterial agents is necessary to cause an infection. Many of these agents can survive naturally in the environment (e.g. *Aeromonas punctata*, *Aeromonas salmonicida*) and/or in the digestive tract of clinically healthy fish; with an increase in their virulence and/or a weakening of the host organism (e.g. due to a polluted aquatic environment) these agents can act as causative factors in the outbreak of a bacterial disease.

Organic pollution of water, followed by a decreased content of dissolved oxygen, creates a favourable environment for the growth of bacteria. A direct relationship between the organic pollution of surface waters and outbreaks of furunculosis is well

established, so that this disease may at times serve as a positive indicator of poor water quality; the causative agent, *Aeromonas salmonicida*, can survive for a maximum of one week in tap water, 12 weeks in stream water and as long as 6 months in organically polluted mud. Organic pollution of the aquatic environment is also an important factor in columnaris infection. Vibriosis occurs most frequently in brackish water, although in inland waters it can be found in localities receiving inputs of salt. Organic and even physical (e.g. inert suspended solids) pollution of water can be important factors in inducing flexibacteriosis in the gills of salmonids, by damaging the delicate gill respiratory epithelium.

6.3 Fungal diseases

A direct relationship between branchiomycosis and organic pollution of water is well known in fish culture practice. Usually, the disease is endemic in ponds and reservoirs; cyprinid fish species, whitefish, pike, but also wels and rainbow trout can be affected. The outbreak and duration of the disease depend on ambient environmental factors, the most important of which is water temperature. The disease occurs most frequently when the water temperature is above 20°C (with an optimum of 26°C) and is accompanied by organic pollution and associated fluctuations in the dissolved oxygen concentrations. Mechanical (i.e. physical) and/or chemical damage of the protective mucus layer of the skin, fins and gills are prerequisites for the disease outbreak. Such damage is also a precondition for the secondary development of saprolegnia; fungal spores develop to form greyish-whitish woolly growths on the damaged surfaces, particularly in weakened fish.

6.4 Fish parasites

The degree of pathogenic activity exerted by ecto- and endoparasites living on the body surface and/or in internal organs of fish, can be influenced by water pollution (KHAN and THULIN, 1991). Contaminating substances such as pesticides may have a harmful effect on the parasites but fish weakened by parasite infestation may be more sensitive to the toxic effects of substances in the water.

For a number of fish protozooses there is a conditional dependence on organic and other pollution of the aquatic environment; for example, such a reduction in water quality can be followed by a gill invasion with *Cryptobia branchialis*. Reduced pH values of the water (e.g. to 5–6), together with unsuitable breeding conditions, can contribute to an outbreak of ichthyobodosis. Poor hygienic conditions in ponds and reservoirs carry a potential danger for myxosporeoses outbreaks; low dissolved oxygen concentrations associated with low light conditions are favourable for chilodonellosis. Thermal pollution can lead to lethal outbreaks of ichthyophthiriosis. Domestic sewage discharged into surface waters can be a source of high populations of trichodines. Phenol and polychloropinen can cause fish to become more sensitive to *Ichthyophthirius multifiliis*; an increased sensitivity of carp to this parasite has also been found in connection with sublethal concentrations of cadmium.

As for the commonly found helminthoses, the relationship between a low oxygen concentration in water and the complicated course of dactylogyroses is well known. The oxygen content of the water is also an important factor affecting the growth and abundance of *Gyrodactylus sp.* populations; for example, a decrease in oxygen concentration of 50% caused a three to four-fold increase in their reproduction rate. This effect is probably caused by the weakening of the host organisms under these conditions rather than the direct effect of an oxygen deficiency on the parasites. Several Finnish authors (Koskivaara et al., 1991; Koskivaara and Valtonen, 1992) have found a

high prevalence of monogenea, particularly the species *Dactylogyrus similis*, *D. fallax*, *Gyrodactylus gasterostei*, *G. carasii* and *G. vimbi*, in fish from lakes polluted by papermill effluents. However, this type of pollution also caused a decreased infestation of gill parasites in the fish.

Contamination of the aquatic environment can even affect the prevalence and intensity of the infestation of fish with multicellular endoparasites. In such cases, pollutants can act either on the intermediate host or directly on the fish organism, and can also affect the associated defence mechanisms and immune responses. In heavily polluted water bodies, there is a strong relationship between a high prevalence of parasites and the condition of the fish. A poor state of fish health is the result of enhanced effects of the parasites on fish harmed by the direct effects of pollution, rather than of the primary effect of the parasites themselves. However, it may be difficult to assign an increase in fish sensitivity to a primary cause, i.e. to the pollutant or the parasite. Nevertheless, it is clear that such an association can exist; carp fingerlings infested with tapeworm *Bothriocephalus gowkongensis* were found to be more sensitive to DDT (Perevozchenko and Davydov, 1974), and Pascoe and Cram (1977) found a higher sensitivity of stickleback to cadmium when infested with the tapeworm *Schistocephalus solidus*.

6.5 Conclusion

Substances which contaminate the aquatic environment can be harmful not only by their direct effects on the organisms there. It is well established that some diseases and developmental abnormalities may occur more frequently in fish living in a polluted environment. However, there is only a limited amount of information on this association, which is mainly related to experiences with farmed or cultured fish. Apart from the examples given above, other similar information is available, some of which is given in Table 4. The limited number of environmental stressors involved - low dissolved oxygen, extremes of temperature and pH, and ammonia - are probably due to the siting of fish farms on relatively unpolluted waters. There is now a real need to study the interrelationships between the pollution of surface waters by a wide range of chemicals and diseases in natural fish populations, and the processes involved. This represents an important but at present under-developed field of scientific research and fisheries management.

REFERENCES

- Alabaster J.S., Lloyd R. (1980): Water quality criteria for freshwater fish. Butterworths. pp. 297.
- Birge W.J., Black J.A., Hudson J.E., Bruser D.M. (1977): Embryo-larval toxicity test with organic compounds. Aquatic Toxicology. Proc. of the Second Annual Symposium on Aquatic Toxicology; Philadelphia, American Society for Testing and Materials.
- Bohl M. (1989): Optimal water quality-basis of fish health and economical production. Current trends in fish therapy. Deutsche Veterinärmedizinische Gesellschaft e. V., Giessen, 18–32.
- Hrbáček J. et al. (1974): Limnological methods. SPN, Praha pp. 208 (In Czech).
- Khan R.A., Thulin J. (1991): Influence of pollution on parasites of aquatic animals. Advances in Parasitology, 30, 202–238.

Koskivaara M., Valtonen E.T., Prost M. (1991): Seasonal occurrence of gyrodactylid monogeneans on the roach (*Rutilus rutilus*) and variations between four lakes of differing water quality in Finland. *Aqua Fennica* 21, 47–55.

Koskivaara M., Valtonen E.T. (1992): *Dactylogyrus* (Monogenea) communities in three lakes in central Finland. *Parasitology*. 104, 263–272.

Lewis W.M., Morris D.P. (1986): Toxicity of nitrite to fish: A review. *Trans. Amer. Fish. Soc.*, 115, No. 2, 183–195.

Lloyd R. (1992): Pollution and freshwater fish. Fishing News Books, Oxford, UK., pp. 192

Mattheis Th., Sommer M. Ch, Grahl K. (1984); Datensammlung der Grenzkonzentrationen von Schadstoffen für die Fischproduktion. III. Polychlorierte Biphenyle. Institut für Binnenfischerei, Berlin, pp. 58.

Pascoe D., Cram P. (1977): The effect of parasitism on the toxicity of cadmium to the three-spined stickleback, *Gasterosteus aculeatus* L.J. *Fish Biol.* 10, 467–472.

Perevozchenko I.I., Davydov O.N. (1974): DDT and its metabolites in some cestodes in fishes. *Gidrobiologicheskii Zhurnal* 10, 86–90.

Pitter P. (1974): Design of standard test for assessment of biological degradability of organic substances. *Vod. Hospod.*, B, 24, 247–250 (In Czech).

Schreckenbach K. (1982): Die Bedeutung von Umweltfaktoren bei der Fischproduktion in Binnengewässern. *Mh. Vet. Med.*, 37, 220–230.

Svobodová Z., Faina R. (1984): Application of Soldep in fish culture. *Vodňany, VÚRH, Edition of Methods*, 12, pp. 15. (In Czech).

Svobodová Z., Vykusová B. (1991): Determining the maximum admissible concentrations of substances in water from the point of view of fish culture requirements. Research Institute of Fish Culture and Hydrobiology, Vodňany

Svobodová Z. et al. (1987): Toxicology of aquatic animals. SZN, Praha, pp. 231 (In Czech).

Taege M. (1982): Brutfrühsterben bei Karpfen (*Cyprinus carpio*) nach industriemässiger Erbrütung und ihre Ursachen. III. Der Einfluss des Kohlendioxid-Gehaltes des Wassers auf die Lebensfähigkeit von Karpfenbrut und den physiologischen Zustand von Karpfen. *Z. Binnenfisch.* DDR, 29, 18–24.

Vámos R., Szöllözy G. (1974): There is not a danger of ammonia intoxication of fish if there is enough oxygen in water. *Halászat*, 20, No. 4, 124 (In Hungarian).

Wedemeyer, G.A., McLeay, O.J. (1981): Methods for determining the tolerance of fishes to environmental stressors. In: Pickering: *Stress and fish*. Academic Press, London, N.J., Toronto, Sydney, San Francisco, p. 247–275.

Wood, J. (1974): Diseases of Pacific Salmon, their prevention and treatment. State of Washington, Dep. of Fisheries, 2nd Ed.

CENTRAL AND EAST EUROPEAN LITERATURE

Baier Ch., Hürle K., Kirchhoff J. (1985): Datensammlung zur Abschätzung des Gefährdungspotentials von Pflanzenschutzmittel-Wirkstoffen für Gewässer. Verlag Paul Parey, Hamburg, Berlin, pp. 294.

Horáková M., Lischke P., Grünwald A. (1989): Chemical and physical methods of water analyses. SNTL, ALFA, Praha, pp. 389 (In Czech).

Lesnikov L.A. (1979): Elaboration of standards of acceptable concentration of pollutants in the water of fish culture units. Sbornik nauchnykh trudov, GosNIORCH, Leningrad, 144, 3–41 (In Russian).

Liebmann H. (1960): Handbuch der Frischwasser-und Abwasserbiologie. VEB Gustav Fischer Verlag, Jena, pp. 1149.

Lukyanenko V.I. (1967): Fish toxicology. Pishchevaya promyshlennost, pp. 216 (In Russian).

Mattheis Th., Taege M. (1982): Datensammlung der Grenzkonzentrationen von Schadstoffen für die Fischproduktion. II. Tenside. Institut für Binnenfischerei, Berlin, pp. 54.

Pitter P. (1981): The effect of pH, temperature and conductivity on relative share of different forms of ammonium nitrogen in water. Vod. Hospod., B, 31, 217–219 (In Czech).

Pitter P. (1990): Hydrochemistry. SNTL, Praha, pp. 565 (In Czech).

Rotschein J. (1970): The effect of oils and refined products on biology and characteristics of surface water. Bratislava, VÚV, pp. 59. (In Slovak)

Schäperclaus W. et al. (1979): Fischkrankheiten. Akademie-Verlag, Berlin, pp. 1089.

Svobodová Z., Máchová J. (1985): Causes, diagnostics and prevention of fish intoxication. ÚVO, Pardubice, pp. 136 (In Czech).

Revised report on fish toxicity testing procedures. FAO-EIFAC, Rome, Techn. Paper, 24, 1983, pp. 37.

Wasserschadstoff-Katalog. Institute für Wasserwirtschaft, Berlin, 1981.

EUROPEAN INLAND FISHERIES ADVISORY COMMISSION (EIFAC)

EIFAC documents are issued in two series:

EIFAC Technical Papers

Selected scientific and technical papers, including some of those contributed as working documents to sessions of the Commission or its Sub-Commissions. Published in English and French, or one of these languages.

EIFAC Occasional Papers

Papers of general interest to the Commission. Published in the language submitted, either in English or French, sometimes in both languages.

Copies of these documents, when still available, can be obtained from:

The Secretariat
European Inland Fisheries Advisory Commission
Fisheries Department
FAO
Via delle Terme di Caracalla
00100 Rome, Italy

COMMISSION EUROPEENNE CONSULTATIVE POUR LES PECHES DANS LES EAUX INTERIEURES (CECPI)

Les documents de la CECPI son publiés dans deux séries:

Documents techniques de la CECPI

Documents scientifiques et techniques sélectionnés comprenant certains documents de travail présentés aux sessions de la Commission ou de ses sous-Commissions. Publiés en français et en anglais, ou dans l'une de ces deux langues.

Documents occasionnels de la CECPI

Documents d'intérêt général pour la Commission. Publiés dans la langue d'origine, soit en français, soit en anglais; parfois dans ces deux langues.

Des exemplaires de ces documents peuvent être obtenus, lorsqu'ils sont encore disponibles, en s'adressant au:

Secrétariat
Commission européenne consultative pour les pêches dans les eaux intérieures
Département des pêches
FAO
Via delle Terme di Caracalla
00100 Rome, Italie

EIFAC TECHNICAL PAPERS
DOCUMENTS TECHNIQUES DE LA CECPI

EIFAC/T1	Water quality criteria for European freshwater fish. Report on finely divided solids and inland fisheries (1964)
CECPI/T1	Critères de qualité des eaux pour les poissons d'eau douce européens. Rapport sur les solides finement divisés et les pêches intérieures (1964)
EIFAC/T2	Fish diseases. Technical notes submitted to the EIFAC Third Session by Messrs J. Heyl, H. Mann, C.J. Rasmussen and A. van der Struik (1965)/Maladies des poissons. Notes présentées à la troisième session de la CECPI par J. Heyl, H. Mann, C.J. Rasmussen and A. van der Struik (1965)
EIFAC/T3	Feeding in trout and salmon culture. Papers submitted to a symposium, EIFAC Fourth Session (1967)/Alimentation dans l'élevage de la truite et du saumon. Communications présentées à un symposium, quatrième session de la CECPI (1967)
EIFAC/T4	Water quality criteria for European freshwater fish. Report on extreme pH values and inland fisheries (1968)/Critères de qualité des eaux pour les poissons d'eau douce européens. Rapport sur les valeurs extrêmes du pH et les pêches intérieures (1968)
EIFAC/T5	Organization of inland fisheries administration in Europe, by Jean-Louis Gaudet (1968)
CECPI/T5	Organisation de l'administration des pêches intérieures en Europe, par Jean-Louis Gaudet (1968)
EIFAC/T5 Rev.1	Organization of inland fisheries administration in Europe. Revised edition (1974)
CECPI/T5 Rev.1	Organisation de l'administration des pêches en Europe. Edition révisée (1974)
EIFAC/T6	Water quality criteria for European freshwater fish. Report on water temperature and inland fisheries based mainly on Slavonic literature (1968)/Critères de qualité des eaux pour les poissons d'eau douce européens. Rapport sur la température de l'eau et les pêches intérieures basé essentiellement sur la documentation slave (1968)
EIFAC/T7	Economic evaluation of inland sport fishing, by Ingemar Norling/Evaluation économique de la pêche sportive dans les eaux continentales, par Ingemar Norling (1968)
EIFAC/T8	Water quality criteria for European freshwater fish. List of literature on the effect of water temperature on fish (1969)/Critères de qualité des eaux pour les poissons d'eau douce européens. Références bibliographiques sur les effets de la température de l'eau sur le poisson (1969)

EIFAC/T9	New developments in carp and trout nutrition. Papers submitted to a symposium, EIFAC Fifth Session (1969)/Récents développements dans la nutrition de la carpe et de la truite. Communications présentées à un symposium, cinquième session de la CECPI (1969)
EIFAC/T10	Comparative study of laws and regulations governing the international traffic in live fish and fish eggs, by F.B. Zenny, FAO Legislation Branch (1969)/Etude comparée des mesures législatives et administratives régissant les échanges internationaux de poissons vivants et d'oeufs de poisson, par F.B. Zenny, Service de législation de la FAO (1969)
EIFAC/T11	Water quality criteria for European freshwater fish. Report on ammonia and inland fisheries (1970)
CECPI/T11	Critères de qualité des eaux pour les poissons d'eau douce européens. Rapport sur l'ammoniac et les pêches intérieures (1971)
EIFAC/T12	Salmon and trout feeds and feeding (1971)
CECPI/T12	Aliments du saumon et de la truite et leur distribution (1973)
EIFAC/T13	Some considerations on the theory of age determination of fish from their scales-Finding proofs of reliability, by R. Sych (1971)
EIFAC/T14	EIFAC consultation on eel fishing gear and techniques/Consultation de la CECPI sur les engins et techniques de pêche à l'anguille (1971)
EIFAC/T15	Water quality criteria for European freshwater fish. Report on monohydric phenols and inland fisheries (1972)
CECPI/T15	Critères de qualité des eaux pour les poissons d'eau douce européens: rapport sur les phénols monohydratés et les pêches intérieures (1973)
EIFAC/T16	Symposium on the nature and extent of water pollution problems affecting inland fisheries in Europe. Synthesis of national reports (1972)
CECPI/T16	Symposium sur la nature et l'étendue des problèmes de pollution des eaux affectant les pêches continentales en Europe. Synthèse des rapports nationaux (1972)
EIFAC/T17	Report of the Symposium on the Major Communicable Fish Diseases in Europe and their Control. (1972)
CECPI/T17	Rapport du Symposium sur les principales maladies transmissibles des poissons en Europe et la lutte contre celles-ci (1973)
EIFAC/T17 Suppl. 1	The major communicable fish diseases of Europe and North America. A review of national and international measures for their control, by P.E. Thompson, W.A. Dill and G. Moore (1973)
CECPI/T17 Suppl.1	Les principales maladies transmissibles des poissons en Europe et en Amérique du Nord: examen de mesures nationales et internationales sur la lutte contre ces maladies, par P.E. Thompson, W.A. Dill et G. Moore (1973)
EIFAC/T17 Suppl.2	Symposium on the Major Communicable Fish Diseases in Europe and their Control. Panel reviews and relevant papers (1973)

CECPI/T17 Suppl.2	Symposium sur les principales maladies transmissibles des poissons en Europe et la lutte contre celles-ci: exposés des groupes et communications apparentées (1973)
EIFAC/T18	The role of administrative action as a tool in water pollution control, by G.K. Moore (1973)
CECPI/T18	Le rôle instrumental de l'administration dans la lutte contre la pollution des eaux, par G.K. Moore (1973)
EIFAC/T19	Water quality criteria for European freshwater fish. Report on dissolved oxygen and inland fisheries (1973)
CECPI/T19	Critères de qualité des eaux pour les poissons d'eau douce européens. Rapport sur l'oxygène dissous et les pêches intérieures (1973)
EIFAC/T20	Water quality criteria for European freshwater fish. Rapport on chlorine and freshwater fish (1973)
CECPI/T20	Critères de qualité des eaux pour les poissons d'eau douce européens. Rapport sur le chlore et les poissons d'eau douce (1973)
EIFAC/T21	Water quality criteria for European freshwater fish. Report on zinc and freshwater fish (1973)
CECPI/T21	Critères de qualité des eaux pour les poissons d'eau douce européens. Rapport sur le zinc et les poissons d'eau douce (1973)
EIFAC/T22	Ecological diagnosis in salmonid streams-Method and Example, by R. Cuiat <u>et al.</u> (1973)
CECPI/T22	Diagnose écologique en cours d'eau à salmonidés. Méthode et exemple, par R. Cuiat <u>et al.</u> (1975)
EIFAC/T23	Report on the Symposium on Methodology for the Survey, Monitoring and Appraisal of Fishery Resources in Lakes and Large Rivers (1974)
CECPI/T23	Rapport du Symposium sur les méthodes de prospection, de surveillance et d'évaluation des ressources ichtyologiques dans les lacs et grands cours d'eau (1974)
EIFAC/T23 Suppl.1	Symposium on the Methodology for the Survey, Monitoring and Appraisal of Fishery Resources in Lakes and Large Rivers - Panel reviews and relevant papers. Vol. I and II (1975)/Symposium sur les méthodes de prospection, de surveillance et d'évaluation des ressources ichtyologiques dans les lacs et grands cours d'eau - Exposés des groupes et communications apparentées, Vol. I et II (1975)
EIFAC/T24	Report on fish toxicity testing procedures (1975)
CECPI/T24	Rapport sur les tests de toxicité sur les poissons (1976)
EIFAC/T24 Rev.1	Revised report on fish toxicity testing procedures (1982)
CECPI/T24 Rev.1	Rapport révisé sur les tests de toxicité sur les poissons (1983)
EIFAC/T25	Workshop on controlled reproduction of cultivated fishes - Report and relevant papers (1975)

CECPI/T25	Réunion sur la production contrôlée des poissons d'élevage. Rapport et communications apparentées (1975)
EIFAC/T26	Economic evaluation of sport and commercial fisheries. Report and technical papers
CECPI/T26	Deuxième consultation européenne sur l'évaluation économique de la pêche sportive et commerciale. Rapport et communications apparentées (1977)
EIFAC/T27	Water quality criteria for European freshwater fish. Report on copper and freshwater fish (1976)
CECPI/T27	Critères de qualité des eaux pour les poissons d'eau douce européens. Rapport sur le cuivre et les poissons d'eau douce (1976)
EIFAC/T28	Joint ICES/EIFAC Symposium on eel research and management (<i>Anguilla</i> spp.). Report (1976)
CECPI/T28	Symposium conjoint CIEM/CECPI sur la recherche et l'exploitation des anguilles (<i>Anguilla</i> spp.). Rapport (1976)
EIFAC/T29	Water quality criteria for European freshwater fish. Report on the effect of zinc and copper pollution on the salmonid fisheries in a river and lake system in central Norway (1977)
CECPI/T29	Critères de qualité des eaux pour les poissons d'eau douce européens. Rapport sur l'effet de la pollution par le zinc et le cuivre sur les pêcheries de salmonidés dans un système fluvio-lacustre du centre de la Norvège (1977)
EIFAC/T30	Water quality criteria for European freshwater fish. Rapport on cadmium and freshwater fish (1977)
CECPI/T30	Critères de qualité des eaux pour les poissons d'eau douce européens. Rapport sur le cadmium et les poissons d'eau douce (1977)
EIFAC/T31	Report of the Symposium on Finfish Nutrition and Feed Technology (1978)
CECPI/T31	Rapport du symposium sur la nutrition des poissons et la technologie de leurs aliments artificiels (1978)
EIFAC/T32	The value and limitations of various approaches to the monitoring of water quality for freshwater fish (1978)
CECPI/T32	La valeur et les limites des diverses méthodes de surveillance biologique de la qualité des eaux pour les poissons d'eau douce (1978)
EIFAC/T33	Guidelines for sampling fish in freshwater (1980) (priced publication)
EIFAC/T34	EIFAC fishing gear intercalibration experiments (1979)
CECPI/T34	Essais CECPI d'interétalonnage des engins de pêche (1979)
EIFAC/T35	Report of the EIFAC Workshop on Mass Rearing of Fry and Fingerlings of Freshwater Fishes (1979)
CECPI/T35	Rapport du stage CECPI sur la production massive du frai et des alevins en eau douce (1979)

EIFAC/T35 Suppl.1	EIFAC Workshop on Mass Rearing of Fry and Fingerlings of Freshwater Fishes. Papers (1979)
EIFAC/T36	Report of the EIFAC/IUNS and ICES Working Group on Standardization of Methodology in Fish Nutrition Research (1980)
CECPI/T36	Rapport du groupe de travail de la CECPI, de l'UISN et du CIEM sur la normalisation de la méthodologie dans la recherche sur la nutrition des poissons (1980)
EIFAC/T37	Report on combined effects on freshwater fish and other aquatic life of mixtures of toxicants in water (1980)
CECPI/T37	Rapport sur les effets produits par la combinaison de toxiques dans l'eau douce et sur d'autres formes de vie aquatique (1981)
EIFAC/T37 Rev.1	Revised report on combined effects on freshwater fish and other aquatic life of mixtures of toxicants in water (1987)
CECPI/T37 Rev.1	Rapport révisé sur les effets produits par la combinaison de toxiques dans l'eau sur les poissons d'eau douce et sur d'autres formes de vie aquatique (1987)
EIFAC/T38	Report of the Technical Consultation on the Allocation of Fishery Resources (1981)
CECPI/T38	Rapport de la Consultation technique sur la répartition des ressources ichtyologiques (1981)
EIFAC/T39	Utilization of heated effluents and recirculation systems for intensive aquaculture (1981)
CECPI/T39	Rapport du Symposium sur les récents développements de l'utilisation des eaux réchauffées et des eaux recyclées en aquaculture intensive (1981)
EIFAC/T40	Problems of fish culture economics with special reference to carp culture in eastern Europe, by M. Leopold (1981)
EIFAC/T41	Report of the EIFAC Workshop on Fish-farm Effluents, by John S. Alabaster (1982)
EIFAC/T42	Report of the Symposium on Stock Enhancement in the Management of Freshwater Fisheries (1982)
CECPI/T42	Rapport du Symposium sur l'amélioration des stocks dans le cadre de l'aménagement des pêcheries d'eau douce (1983)
EIFAC/T42 Suppl.	Documents presented at the Symposium on Stock Enhancement in the Management of Freshwater Fisheries. Volume 1: Stocking/Documents présentés au Symposium sur l'amélioration des stocks dans le cadre de l'aménagement des pêcheries d'eau douce. Volume 1: Repeuplement (1984)

EIFAC/T42 Suppl.	Documents presented at the Symposium on Stock Enhancement in the Management of Freshwater Fisheries. Volume 2: Introductions and Transplantations/Documents présentés au Symposium sur l'amélioration des stocks dans de cadre de l'aménagement des pêcheries d'eau douce. Volume 2: Introductions et transplantations (1984)
EIFAC/T43	Water quality criteria for European freshwater fish. Report on chromium and freshwater fish (1983)
CECPI/T43	Critères de qualité des eaux pour les poissons d'eau douce européens. Rapport sur le chrome et les poissons d'eau douce (1983)
EIFAC/T44	Report of the EIFAC Working Party on Stock Enhancement/Rapport du groupe de travail de la CECPI sur l'amélioration des stocks (1984)
EIFAC/T45	Water quality criteria for European freshwater fish. Report on nickel and freshwater fish (1984)
CECPI/T45	Critères de qualité des eaux pour les poissons d'eau douce européens. Rapport sur le nickel et les poissons d'eau douce (1984)
EIFAC/T46	Water quality criteria for European freshwater fish. Report on nitrite and freshwater fish (1984)
CECPI/T46	Critères de qualité des eaux pour les poissons d'eau douce européens. Rapport sur les nitrites et les poissons d'eau douce (1984)
EIFAC/T47	Report of the Symposium on Habitat Modification and Freshwater Fisheries/Rapport du Symposium sur les modification de l'habitat et leurs effets sur la pêche continentale (1984)
EIFAC/T48	The transport of live fish - A review, by R. Berka (1986)
CECPI/T48	Le transport des poissons vivants - Etude de synthèse, par R. Berka (1986)
EIFAC/T49	Flow-through and recirculation systems. Report of the Working Group on Terminology, Format and Units of Measurements (1986)
CECPI/T49	Systèmes d'aquaculture ouverts et fermés. Rapport du groupe de travail sur la terminologie, le mode de présentation et les unités de mesure (1986)
EIFAC/T50	Report of the Symposium on Selection, Hybridization and Genetic Engineering in Aquaculture of Fish and Shellfish for Consumption and Stocking/Rapport du Symposium sur la sélection, l'hybridation et le génie génétique en aquaculture des poissons, crustacés et mollusques pour la consommation et le repeuplement (1986)
EIFAC/T51	Report of the EIFAC Working Party on Prevention and Control of Bird Predation in Aquaculture and Fisheries Operations (1989)
EIFAC/T52	Inland fisheries of Europe, by W.A. Dill (1990)
EIFAC/T52 Suppl.	Inland fisheries of Europe, by W.A. Dill (1993)

EIFAC/T53 Report of the Symposium on Production Enhancement in Still-water Pond Culture/Rapport du Symposium sur l'accroissement de la production des élevages aquacoles dans les plans d'eaux stagnants et peu profonds (1990)

EIFAC/T54 Water quality and fish health, by Z. Svobodová, R. Lloyd, J. Máchová and B. Vykusová (1993)

EIFAC OCCASIONAL PAPERS
DOCUMENTS OCCASIONNELS DE LA CECPI

EIFAC/OP1 Summary of the organized discussion on the economic evaluation of sport fishing (1968)

EIFAC/OP2 Bibliography on nutritional requirements of salmonoid fishes/Bibliographie sur les besoins nutritifs des salmonidés (1968)

EIFAC/OP3 Application of electricity to freshwater fishery management and development in Ireland (1969)

CECPI/OP4 Les pêcheries de la Roumanie et la pêche roumaine (1970)

EIFAC/OP5 Potential uses of waste waters and heated effluents (1971)

EIFAC/OP6 Investigation of a method for comparing the efficiency of portable fishing machines/Etude d'une méthode permettant de comparer l'efficacité d'appareils de pêche électriques portables (1973)

EIFAC/OP7 Economic issues and opportunities facing Europe in the field of sport fisheries/Problèmes et possibilités économiques de la pêche sportive en Europe (1973)

EIFAC/OP8 Pond fish culture in Czechoslovakia (1973)

EIFAC/OP9 A review of feeding equipment in fish culture (1973)

EIFAC/OP10 Bibliography on nutritional requirements of warm-water fishes/Bibliographie sur les besoins nutritifs des poissons vivant en eaux chaudes (1975)

EIFAC/OP11 Survey of ownership and utilization of inland fisheries in various European countries and Canada (1976)

EIFAC/OP12 Glossary of inland fishery terms/Glossaire de termes utilisés dans le domaine des pêches intérieures (1978)

EIFAC/OP13 Historical review of EIFAC activities (1981)

CECPI/OP13 Aperçu historique des activités de la CECPI (1981)

EIFAC/OP14 EIFAC experiments on pelagic fish stock assessment by acoustic methods in Lake Konnevesi, Finland (1982)

EIFAC/OP15	EIFAC experiments in pelagic fish stock assessment by acoustic methods in Lake Constance (1985)
EIFAC/OP16	National reports of EIFAC member countries for the period January 1984–December 1985/Rapports nationaux des pays membres de la CECPI pour la période janvier 1984–décembre 1985 (1986)
EIFAC/OP17	EIFAC experiments on pelagic fish stock assessment by acoustic methods in Lake Tegel (1987)
EIFAC/OP18	Bibliography of existing literature on selectivity of inland water fishing gear published by European authors (1987)
EIFAC/OP19	The decrease in aquatic vegetation in Europe and its consequences for fish populations (1987)
EIFAC/OP20	National reports of EIFAC member countries for the period January 1986–December 1987/Rapports nationaux des pays membres de la CECPI pour la période janvier 1986–décembre 1987 (1988)
EIFAC/OP21	Age determination of <i>Anguilla anguilla</i> (L.) and related species. Marking and tagging methods applied to eel, <i>Anguilla anguilla</i> (L.) (1988)
EIFAC/OP22	Report of the EIFAC Technical Consultation on Genetic Broodstock Management and Breeding Practices of Finfish (1988)
EIFAC/OP23	Codes of practice and manual of procedures for consideration of introductions and transfers of marine and freshwater organisms (1989)
EIFAC/OP24	Code of practice and guidelines for safety with electric fishing (1990)
EIFAC/OP25	Report of the Seventh Session of the Working Party on Eel (1991)
EIFAC/OP26	Report of the International Seminar on Mass Removal of (Unwanted) Fish in Large Inland Water Bodies (1991)
EIFAC/OP27	Report of the Eighth Session of the Working Party on Eel (1993)